



EUROPEAN PATENT APPLICATION

Application number : **93202117.3**

Int. Cl.⁵ : **B65B 59/00**

Date of filing : **16.07.93**

Priority : **17.07.92 JP 50249/92 U**

Date of publication of application :
19.01.94 Bulletin 94/03

Designated Contracting States :
CH DE DK FR GB LI NL SE

Applicant : **Shikoku Kakoki Co., Ltd.**
10-1, Aza-Nishinokawa, Tarohachizu,
Kitajima-cho
Itano-gun, Tokushima, 771-02 (JP)

Inventor : **Ueda, Michio, c/o Shikoku Kakoki**
Co., Ltd.
10-1, Aza-Nishinokawa, Tarohachizu,
Kitajima-cho
Itano-gun, Tokushima, 771-02 (JP)

Inventor : **Iuchi, Tetsuya, c/o Shikoku Kakoki**
Co., Ltd.

10-1, Aza-Nishinokawa, Tarohachizu,
Kitajima-cho
Itano-gun, Tokushima, 771-02 (JP)

Inventor : **Nobuta, Masao, c/o Shikoku Kakoki**
Co., Ltd.

10-1, Aza-Nishinokawa, Tarohachizu,
Kitajima-cho
Itano-gun, Tokushima, 771-02 (JP)

Inventor : **Hashimoto, Seiji, c/o Shikoku Kakoki**
Co., Ltd.

10-1, Aza-Nishinokawa, Tarohachizu,
Kitajima-cho
Itano-gun, Tokushima, 771-02 (JP)

Representative : **Vollebregt, Cornelis Jacobus,**
Ir.
P.O. Box 645
NL-5600 AP Eindhoven (NL)

Adjustable packaging machine.

A packaging machine comprising a container conveyor 12 mounted on a bed 11, and a group of devices mounted on the bed 11 and successively arranged along the path of transport of the conveyor, the group of devices including at least a filling device 15 and a sealing device 17. The bed 11 comprises a pair of side frames 24 extending in parallel to the direction of transport of the conveyor, and a plurality of holders 31-37 connected between the frames 24 and corresponding in number to the number of the devices, the holders respectively having the devices attached thereto. At least one of the holders, 34, is movable longitudinally of the side frames 24, and is releasably fixed at a desired position along the length of the side frames 24 by fixing means.

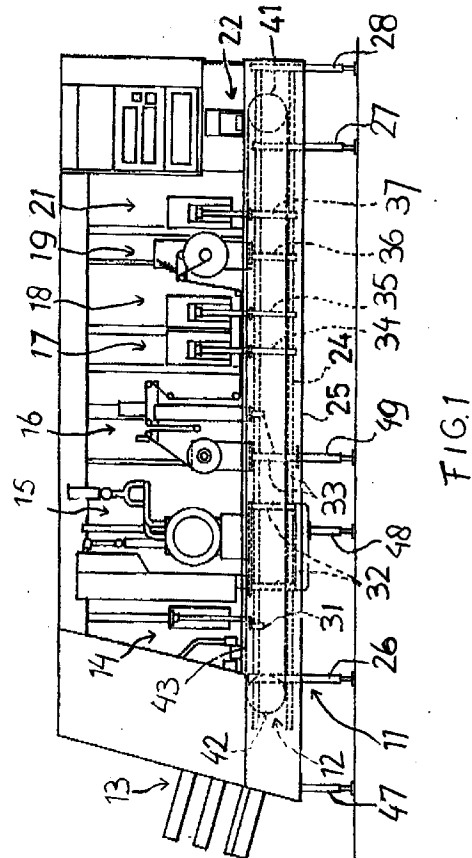

BACKGROUND OF THE INVENTION

The present invention relates to packaging machines, for example, to a packaging machine for filling dessert into cuplike containers and thereafter closing the opening of each container with a strip of closure material.

Packaging machines of the type mentioned are already known which comprise a container conveyor mounted on a bed, and a group of devices mounted on the bed and successively arranged along the path of transport of the conveyor, the group of devices including at least a container feeder, filling device, sealing device and container discharging device. The bed comprises a pair of opposite side frames extending in parallel to the direction of transport of the conveyor, and a plurality of holders connected between the frames and corresponding in number to the number of devices. The holders respectively have the devices attached thereto and are secured to the side frames by welding.

When it is attempted to change the position of some of the devices of the above packaging machine to alter the layout of the group of devices, difficulty is encountered in changing the position of devices, for example, because there arises a need to prepare a new bed.

SUMMARY OF THE INVENTION

The main object of the present invention is to provide a packaging machine which readily permits alteration of the layout of component devices.

The present invention provides a packaging machine which comprises a container conveyor mounted on a bed, and a group of devices mounted on the bed and successively arranged along the path of transport of the conveyor, the group of devices including at least a filling device and a sealing device, the bed comprising a pair of side frames extending in parallel to the direction of transport of the conveyor, and a plurality of holders connected between the frames and corresponding in number to the number of the devices, the holders respectively having the devices attached thereto. The packaging machine is characterized in that at least one of the holders is movable longitudinally of the side frames and has fixing means for releasably fixing the movable holder at a desired position along the length of the side frames.

With the packaging machine of the present invention, at least one of the holders is free to move longitudinally of the side frames, and the machine has fixing means for releasably fixing the movable holder at an optional position along the length of the side frames, so that the position of the device can be altered by unfastening the holder from the side frames, moving the holder and fixing the holder to the side frames again. Thus, the position of the device can be

altered readily.

BRIEF DESCRIPTION OF THE DRAWINGS

- 5 FIG. 1 is a side elevation showing a packaging machine embodying the invention;
 FIG. 2 is a perspective view showing a portion of the packaging machine including a sealing device;
 10 FIG. 3 is a view in cross section of the portion shown in FIG. 2;
 FIG. 4 is an enlarged fragmentary view in section of FIG. 3;
 15 FIG. 5 is a side elevation of the portion shown in FIG. 4; and
 FIG. 6 is a side elevation corresponding to FIG. 1 and showing another embodiment.

DESCRIPTION OF THE PREFERRED EMBODIMENTS

Embodiments of the invention will be described below with reference to the drawings. In the following description, the term "front" refers to the side (right-hand side of FIG. 1) toward which containers advance as transported by the conveyor, and the term "rear" to the opposite side. The terms "right" and "left" are used for the machine as it is seen from the front rearward, and refer to the right and the left of FIG. 3.

30 FIG. 1 shows a packaging machine, which comprises a bed 11, a container conveyor 12 mounted on the bed, and a container feeder 13, extraneous matter removing device 14, filling device 15, rewinder 16, sealing device 17, trimmer 18, winder 19, skirt folding device 21 and discharge device 22 which are arranged along the path of transport of the conveyor 12.

As shown in detail in FIGS. 2 and 3, the bed 11 comprises right and left side frames 24, right and left side covers 25 covering the respective side frames 24 from outside, three pairs of right and left support legs 26, 27, 28 fixed to the side frames 24 respectively at three locations, i.e., near their rear ends, near their front ends and at the front ends, and seven kinds of holders 31 to 37 fixed to the side frames 24 and respectively having attached thereto the removing device 14, filling device 15, rewinder 16, sealing device 17, trimmer 18, winder 19 and folding device 21 included in the group of devices and other than the container feeder 13 and discharge device 22.

The container conveyor 12, which is a slat conveyor, comprises a pair of opposite front drive sprockets 41 and a pair of opposite rear driven sprockets 42 which are mounted on the respective side frames 24 by suitable means not shown in detail, a pair of opposite chains reeved around the sprockets 41, 42 at the respective sides, and a multiplicity of slats 45 connected between the chains 43 (see FIG. 3).

The container feeder 13 and discharge device 22 are fixed to the side frames 24 by suitable means not shown in detail. The container feeder 13 is provided with a pair of right and left auxiliary support legs 47. Of the seven kinds of holders 31 to 37, the holders 32 for the filling device and the holders 33 for the winder are provided with a pair of right and left auxiliary support legs 48 and like auxiliary support legs 49, respectively.

Each of the side frames 24 comprises upper and lower guide rails 51, 52 made of a pipe of circular cross section and extending in parallel to each other longitudinally of the machine.

FIG. 2 shows structures for fixing typical one of the three pairs of support legs 26, 27, 28, i.e., the support leg 28 at the front frame ends, to the side frames 24.

Since the structures for fixing the support legs 28 to the side frames 24 at the respective right and left sides have the same construction although oriented in opposite laterals directions, the structure for the support leg 28 on the left side will be described.

The front ends of the upper and lower rails 51, 52 of the side frame 24 are held between the support leg 28 and upper and lower two vertical flat platelike clamp members 53 provided on the left side face of the leg. The support leg 28 is formed at upper portions thereof with U-shaped leftwardly open cutouts 54, in which the upper and lower rails 51, 52 are fitted, respectively, with a left side portion of each rail slightly projecting from the cutout 54. On the other hand, each of the clamp members 53 is formed at the mid-portion of its length with an arcuate cutout 55 having fitted therein the projecting portion of the rail 51 (52). Two fastening bolts 56 extend through the clamp member 53 at its upper and lower end portions and are screwed into the support leg 28. Two horizontal connecting bars 57 are connected between the opposite support legs 28 at lower portions thereof.

When the bolts 56 are loosened, the support leg 28 is free to move along the rails 51, 52, whereas when the bolts 56 are tightened up, the support leg 28 is fixed to the rails 51, 52 at the position where the leg is located.

FIGS. 2 and 3 show a structure for fixing the sealing device holder 34, which is typical of the seven kinds of holders 31 to 37, to the side frames 24.

The holder 34 comprises a pair of right and left vertical members 61 extending across the upper and lower guide rails 51, 52 of the respective side frames 24, and a transverse member 62 provided between these vertical members 61.

With reference to FIGS. 4 and 5, the upper and lower rails 51, 52 of the left side frame 24 are held between the vertical member 61 and upper and lower two clamp members 63 provided on the left side face of the member 61 and each in the form of a vertical flat plate. The vertical member 61 is formed with two

semicircular leftwardly open cutouts 64 having fitted therein approximately right halves of the upper and lower rails 51, 52. On the other hand, each clamp member 63 is formed at the midportion of its length with a semicircular rightwardly open cutout 65 having fitted therein approximately the left half of the rail 51 (52). Two fastening bolts 66 extend through the clamp member 63 at its upper and lower end portions and are screwed into the vertical member 61.

Right and left posts 68 are provided upright on the upper ends of the respective vertical members 61 by means of connectors 67. The upper ends of the posts 68 are interconnected by a top plate 69, from which the sealing device 17 is suspended. The transverse member 62 is provided with backup members 71 which are vertical plates arranged in parallel for receiving the pressure of sealing operation.

As in the case of the support leg 28 described, the holder 34 is free to move with the sealing device 17 along the rails 51, 52 when the bolts 66 are loosened. When the bolts 66 are tightened up, the holder 34 is fastened to the rails 51, 52 in place.

FIG. 6 shows a modified packaging machine comprising the machine shown in FIG. 1 and further having incorporated therein optional devices, which lengthened the machine.

The modified packaging machine comprises a bed 81 and the devices of FIG. 1 mounted thereon, i.e., the container feeder 13, extraneous matter removing device 14, filling device 15, rewinder 16, sealing device 17, trimmer 18, winder 19, skirt folding device 21 and discharge device. Additionally, the machine has a secondary filling device 82 and a secondary rewinder 83 which are arranged between the filling device 15 and the rewinder 16, and a secondary sealing device 84 disposed between the sealing device 17 and the trimmer 18. These three devices 82 to 84 are also fixed to side frames 88 of the bed 81 by holders 85 to 87, respectively.

When the bed 11 of the packaging machine of FIG. 1 is to be modified into the bed 81 of the machine shown in FIG. 6, the rails 51, 52 of the side frames 24 of the former bed 11 are replaced by elongated ones in conformity with the length of the side frames 88 of the latter bed 81.

Claims

1. A packaging machine comprising a container conveyor 12 mounted on a bed 11, and a group of devices mounted on the bed 11 and successively arranged along the path of transport of the conveyor, the group of devices including at least a filling device 15 and a sealing device 17, the bed 11 comprising a pair of side frames 24 extending in parallel to the direction of transport of the conveyor, and a plurality of holders 31-37

connected between the frames 24 and corresponding in number to the number of the devices, the holders respectively having the devices attached thereto, the packaging machine being characterized in that at least one of the holders, 34, is movable longitudinally of the side frames 24 and has fixing means for releasably fixing the movable holder 34 at a desired position along the length of the side frames 24.

5

10

2. A packaging machine as defined in claim 1 wherein each of the side frames 24 comprises upper and lower guide rails 51, 52, and the movable holder 34 comprises a pair of vertical members 61 each extending across and connected to the upper and lower guide rails 51, 52 at the corresponding side, and a transverse member 62 provided between the pair of vertical members 61, the fixing means comprising a plurality of clamp members 63 holding the upper and lower guide rails 51, 52 between the clamp member and the vertical member 61 at the corresponding side, and a plurality of fastening bolts 66 extending through each of the clamp members 63 and screwed into the corresponding vertical member 61.

15

20

25

3. A packaging machine as defined in claim 1 wherein each of the side frames 24 is supported by a plurality of support legs 26, 27, 28, and at least one of the support legs, 28, at each of opposite sides is movable longitudinally of the side frame 24 and has fixing means for releasably fixing the movable support leg 28 at a desired position along the length of the side frame 24.

30

35

4. A packaging machine as defined in claim 3 which comprises different kinds of side frames 88 having different lengths.

40

5. A packaging machine as defined in claim 3 or 4 wherein each of the side frames 24 comprises upper and lower guide rails 51, 52, and the movable support leg 28 has an upper portion extending across and connected to the upper and lower guide rails 51, 52 at the corresponding side, the fixing means comprising a plurality of clamp members 53 holding the upper and lower guide rails 51, 52 between the clamp member and the support leg 28 at the corresponding side, and a plurality of fastening bolts 56 extending through each of the clamp members 53 and screwed into the corresponding support leg 28.

45

50

55

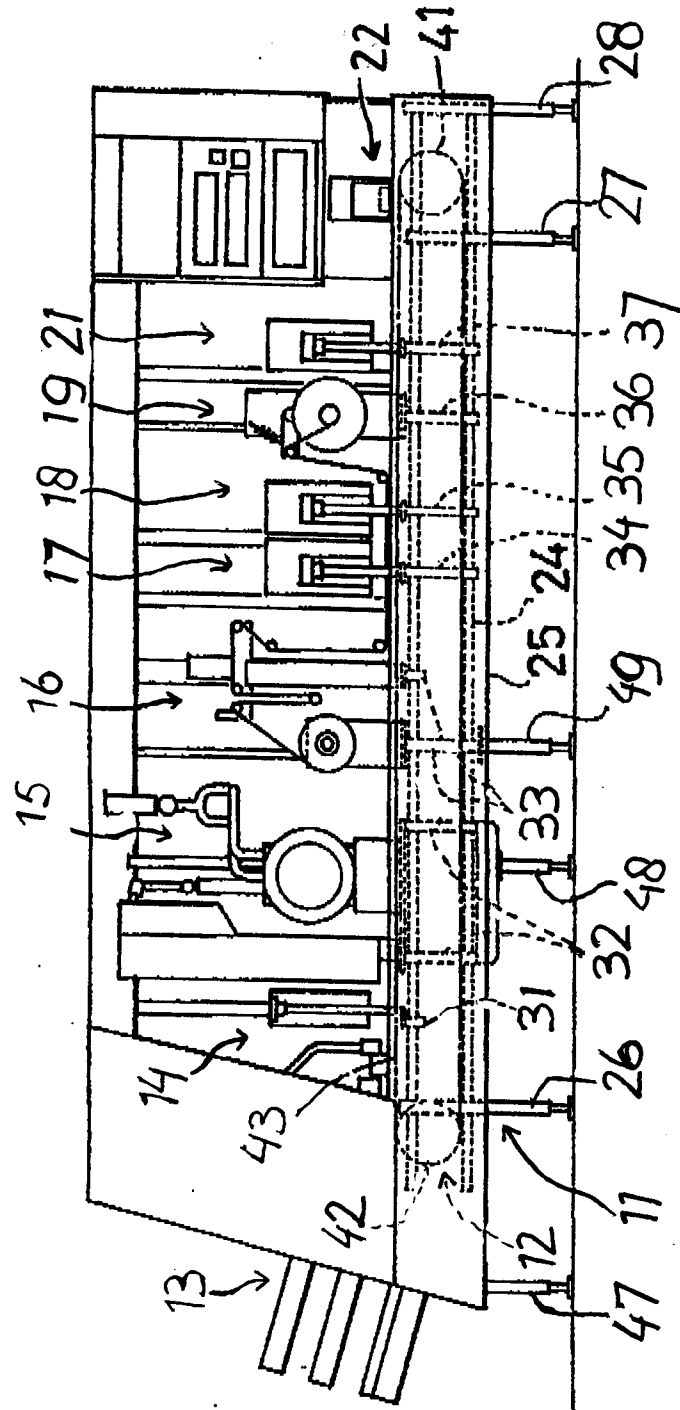

FIG. 1

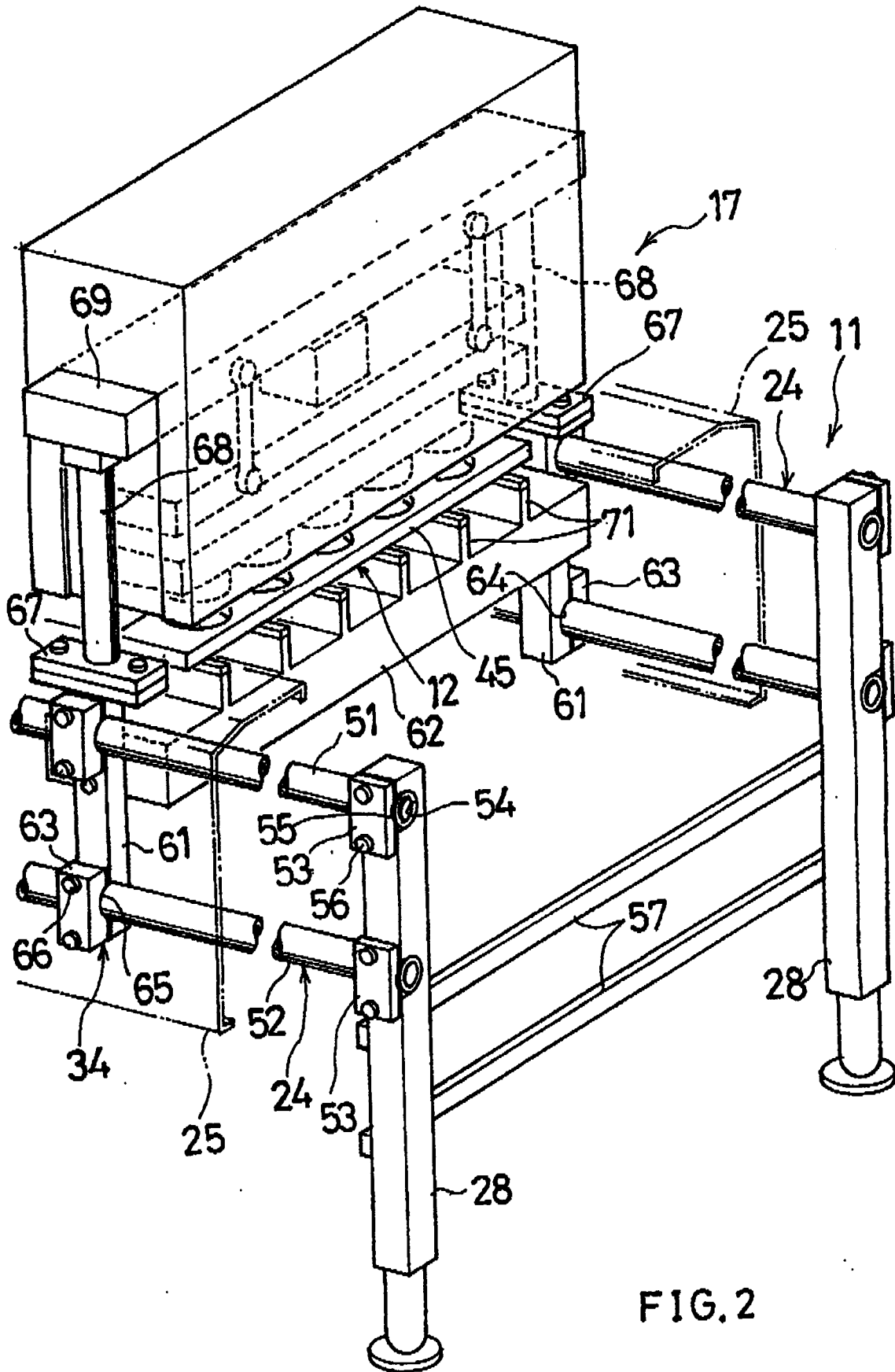

FIG. 2

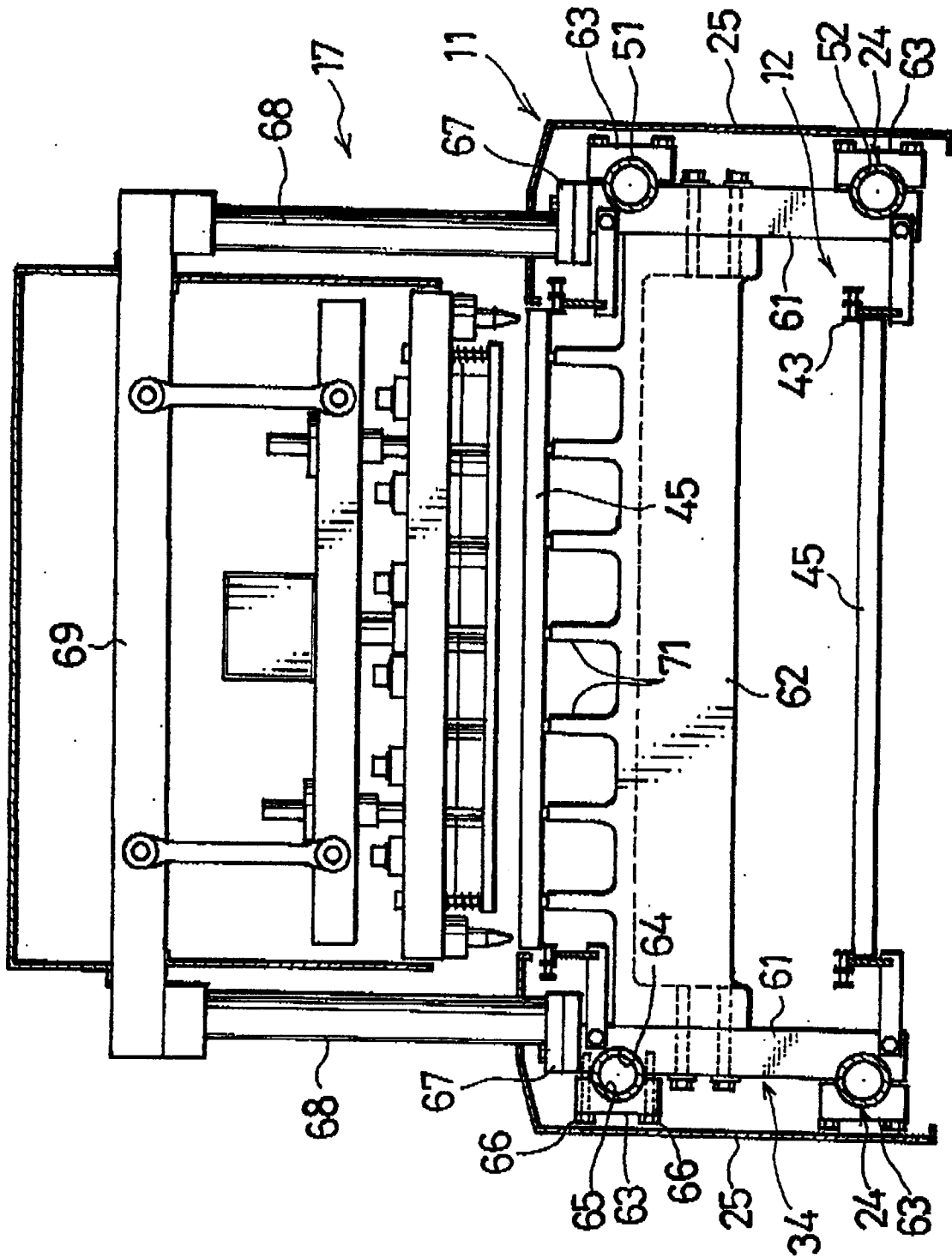

FIG. 3

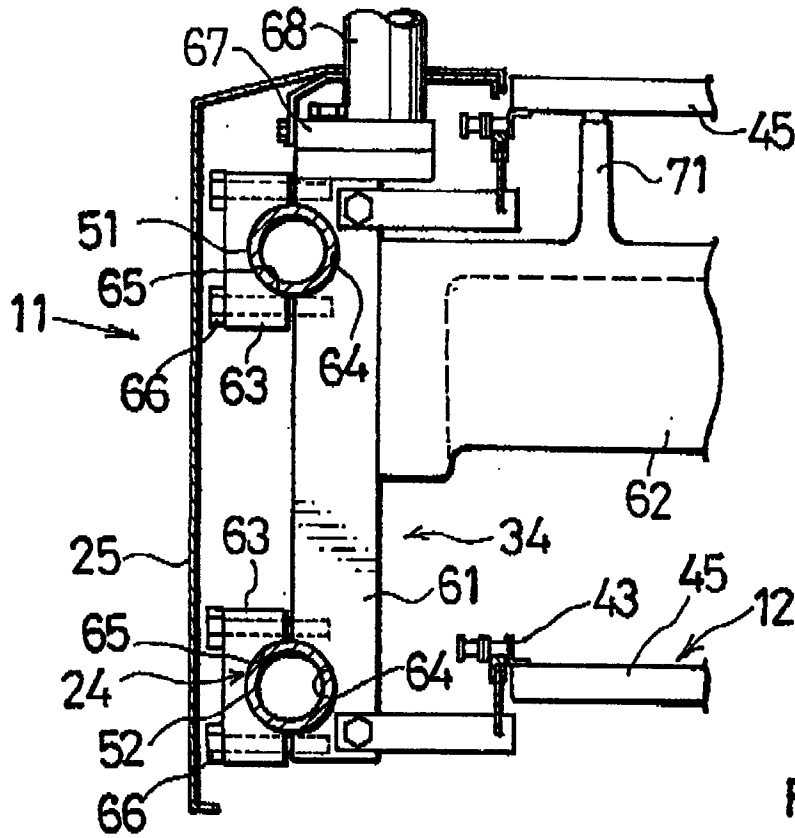

FIG. 4

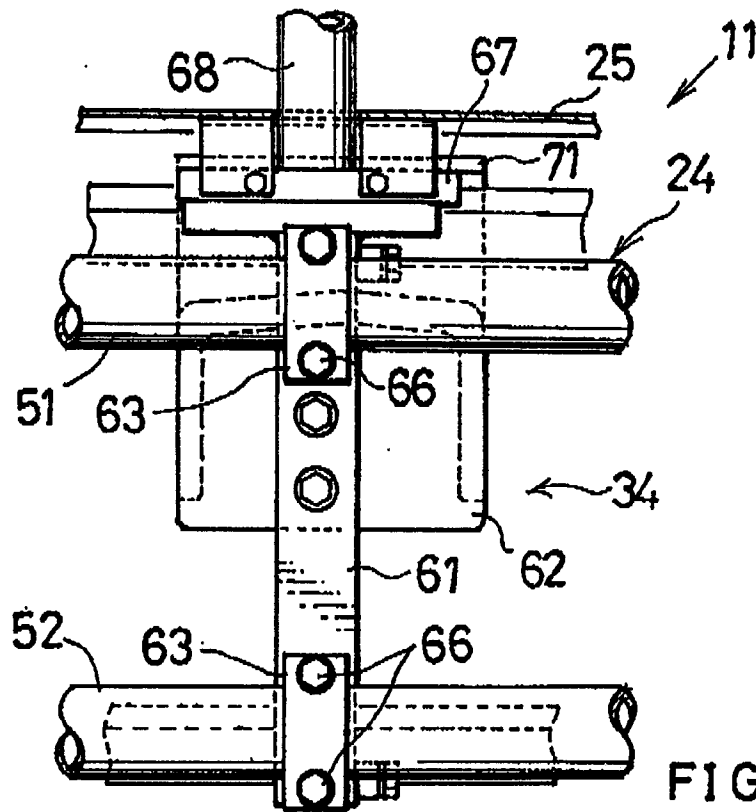

FIG. 5

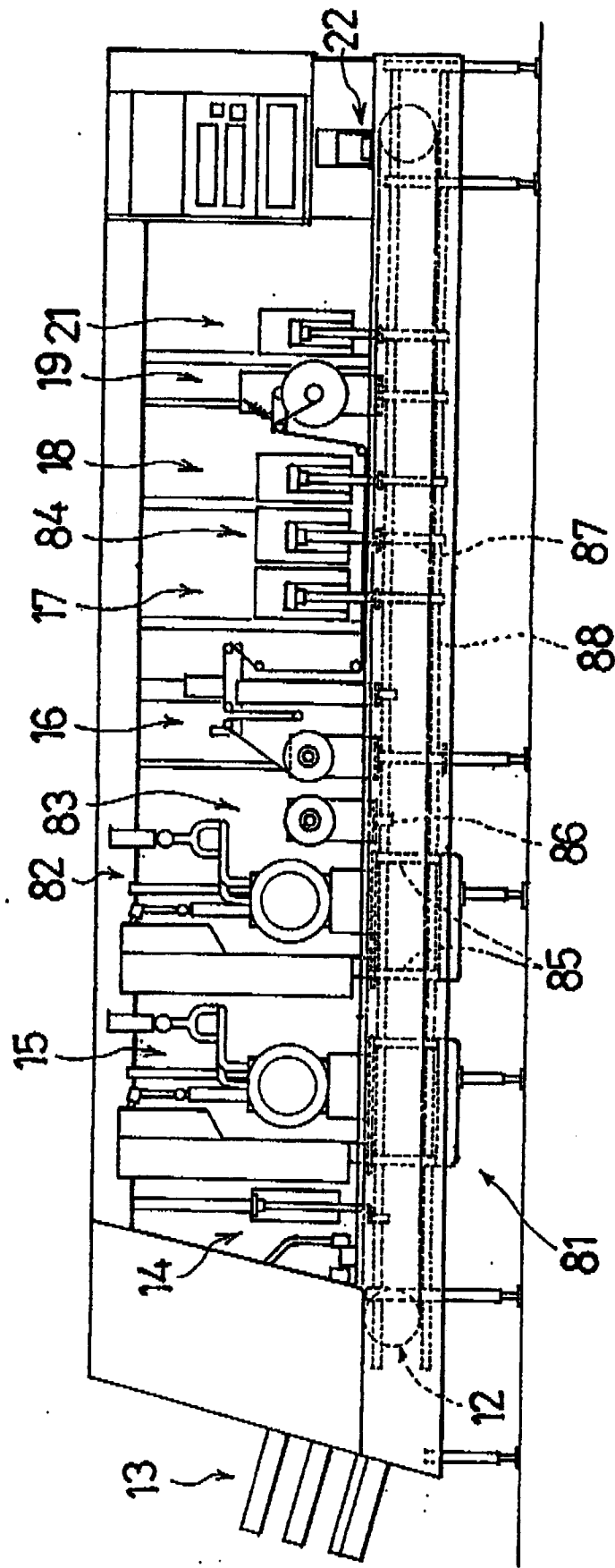

FIG.6