

(19) World Intellectual Property Organization
International Bureau



(43) International Publication Date
20 September 2007 (20.09.2007)

PCT

(10) International Publication Number
WO 2007/106697 A2

- (51) International Patent Classification:
G02B 26/00 (2006.01)
- (21) International Application Number:
PCT/US2007/063500
- (22) International Filing Date: 7 March 2007 (07.03.2007)
- (25) Filing Language: English
- (26) Publication Language: English
- (30) Priority Data:
11/276,676 9 March 2006 (09.03.2006) US
- (71) Applicant (for all designated States except US):
HEWLETT-PACKARD DEVELOPMENT COMPANY, L.P. [US/US]; 20555 S.H. 249, Houston, TX 77070 (US).
- (72) Inventors; and
- (75) Inventors/Applicants (for US only): **KEARL, Daniel, A.** [US/US]; 1000 NE Circle Blvd., Corvallis, OR 97330 (US). **MONROE, Michael, G.** [US/US]; 1000 NE Circle Blvd., Corvallis, OR 97330 (US). **LEWIS, Henry** [US/US]; 1000 NE Circle Blvd., Corvallis, OR 97330 (US). **VALENCIA, Melinda** [US/US]; 1000 NE Circle Blvd., Corvallis, OR 97330 (US). **MCKINNELL, James, C.** [US/US]; 1000 NE Circle Blvd., Corvallis, OR 97330 (US). **PRZYBYLA, James, R.** [US/US]; 1000 NE Circle Blvd., Corvallis, OR 97330 (US). **PIEHL, Arthur** [US/US]; 1000 NE Circle Blvd., Corvallis, OR 97330 (US). **POTOCHNIK, Stephen, J.** [US/US]; 6970 NW Cabernet Place, Corvallis, OR 97330 (US).
- (74) Agents: **MYERS, Timothy F.** et al.; Hewlett-Packard Company, Intellectual Property Administration, P.O. Box 272400||Mail Stop 35, Fort Collins, CO 80527-2400 (US).
- (81) Designated States (unless otherwise indicated, for every kind of national protection available): AE, AG, AL, AM, AT, AU, AZ, BA, BB, BG, BR, BW, BY, BZ, CA, CH, CN, CO, CR, CU, CZ, DE, DK, DM, DZ, EC, EE, EG, ES, FI, GB, GD, GE, GH, GM, GT, HN, HR, HU, ID, IL, IN, IS, JP, KE, KG, KM, KN, KP, KR, KZ, LA, LC, LK, LR, LS, LT, LU, LY, MA, MD, MG, MK, MN, MW, MX, MY, MZ, NA, NG, NI, NO, NZ, OM, PG, PH, PL, PT, RO, RS, RU, SC, SD, SE, SG, SK, SL, SM, SV, SY, TJ, TM, TN, TR, TT, TZ, UA, UG, US, UZ, VC, VN, ZA, ZM, ZW.
- (84) Designated States (unless otherwise indicated, for every kind of regional protection available): ARIPO (BW, GH, GM, KE, LS, MW, MZ, NA, SD, SL, SZ, TZ, UG, ZM, ZW), Eurasian (AM, AZ, BY, KG, KZ, MD, RU, TJ, TM), European (AT, BE, BG, CH, CY, CZ, DE, DK, EE, ES, FI, FR, GB, GR, HU, IE, IS, IT, LT, LU, LV, MC, MT, NL, PL, PT, RO, SE, SI, SK, TR), OAPI (BF, BJ, CF, CG, CI, CM, GA, GN, GQ, GW, ML, MR, NE, SN, TD, TG).
- Declarations under Rule 4.17:**
- as to the identity of the inventor (Rule 4.17(i))
 - as to applicant's entitlement to apply for and be granted a patent (Rule 4.17(ii))
 - as to the applicant's entitlement to claim the priority of the earlier application (Rule 4.17(iii))
- Published:**
- without international search report and to be republished upon receipt of that report
- For two-letter codes and other abbreviations, refer to the "Guidance Notes on Codes and Abbreviations" appearing at the beginning of each regular issue of the PCT Gazette.

(54) Title: FABRY-PEROT INTERFEROMETER COMPOSITE AND METHOD

(57) Abstract: A composite partially reflecting element of a Fabry-Perot interferometer includes a transparent plate having a surface facing toward the optical gap of the interferometer, a partially reflecting layer disposed on the surface of the transparent plate facing toward the optical gap, and at least one protective layer on at least one side of the partially reflecting layer.



WO 2007/106697 A2

5 **FABRY-PEROT INTERFEROMETER COMPOSITE AND METHOD**

CROSS-REFERENCE TO RELATED APPLICATIONS

 This application is related to co-pending and commonly assigned
application serial number 10/428261 (attorney docket no. 10016895-1) filed
10 April 30, 2003; application serial number 11/233045, (attorney docket no.
200504684-1) and application serial number 11/233225, (attorney docket no.
200503982-1), both filed Sept. 21, 2005; application serial number 11/238704
(attorney docket no. 200310614-2) filed Sept. 29, 2005; provisional application
15 serial no. 60/619,380 (attorney docket no. 200310614-1) filed Oct. 14, 2004;
and application serial number 11/284225 (attorney docket no. 200406434-1)
filed Nov. 21, 2005, the entire disclosure of each of which is incorporated herein
by reference.

TECHNICAL FIELD

 This invention relates generally to Fabry-Perot interferometer device
20 structures and methods.

BACKGROUND

There are many applications for light modulator devices that have high spatial and time resolution and high brightness, including applications in displays of information for education, business, science, technology, health, sports, and entertainment. Some light modulator devices, such as digital light-mirror arrays and deformographic displays, have been applied for large-screen projection. For white light, light modulators such as the reflective digital mirror arrays have been developed with high optical efficiency, high fill-factors with resultant low pixelation, convenient electronic driving requirements, and thermal robustness.

Macroscopic scanners have employed mirrors moved by electromagnetic actuators such as "voice-coils" and associated drivers. Micro-mirror devices have used micro-actuators based on micro-electro-mechanical-system (MEMS) techniques. MEMS actuators have also been employed in other applications such as micro-motors, micro-switches, and valves for control of fluid flow. Micro-actuators have been formed on insulators or other substrates using micro-electronic techniques such as photolithography, vapor deposition, and etching.

A micro-mirror device can be operated as a light modulator for amplitude and/or phase modulation of incident light. One application of a micro-mirror device is in a display system. In such a system, multiple micro-mirror devices are arranged in an array such that each micro-mirror device provides one cell or pixel of the display. A conventional micro-mirror device includes an electrostatically actuated mirror supported for rotation about an axis of the mirror into either one of two stable positions. Thus, such a construction serves to provide both light and dark pixel elements corresponding to the two stable positions. For gray scale variation, binary pulse-width modulation has been applied to the tilt of each micro-mirror. Thus, conventional micro-mirror devices have frequently required a high frequency oscillation of the mirror and frequent switching of the mirror position and thus had need for high frequency circuits to drive the mirror. Binary pulse-width modulation has been accomplished by off-chip electronics, controlling on- or off-chip drivers.

Conventional micro-mirror devices must be sufficiently sized to permit rotation of the mirror relative to a supporting structure. Increasing the size of the micro-mirror device, however, reduces resolution of the display since fewer micro-mirror devices can occupy a given area. In addition, applied energies
5 must be sufficient to generate a desired force needed to change the mirror position. Also, there are applications of micro-mirror devices that require positioning of the mirror in a continuous manner by application of an analog signal rather than requiring binary digital positioning controlled by a digital signal. Accordingly, it is desirable to minimize the size of a micro-mirror device
10 so as to maximize the density of an array of such devices, and it is desirable as well to provide means for positioning the micro-mirror device in an analog fashion.

Micro-electromechanical systems (MEMS) are systems which are typically developed using thin film technology and include both electrical and
15 micro-mechanical components. MEMS devices are used in a variety of applications such as optical display systems, pressure sensors, flow sensors, and charge-control actuators. MEMS devices of some types use electrostatic force or energy to move or monitor the movement of micro-mechanical electrodes, which can store charge. In one type of MEMS device, to achieve a
20 desired result, a gap distance between elements is controlled by balancing an electrostatic force and a mechanical restoring force.

MEMS devices designed to perform optical functions (sometimes called micro-optical-electromechanical systems or MOEMS devices) have been developed using a variety of approaches. According to one approach, a
25 deformable deflective membrane is positioned over an electrode and is electrostatically attracted to the electrode. Other approaches use flaps or beams of silicon or aluminum, which form a top conducting layer. For such optical applications, the conducting layer is reflective while the deflective membrane is deformed using electrostatic force to direct light which is incident
30 upon the conducting layer.

More specifically, MEMS of a type called optical interference devices produce colors based on the precise spacing of a pixel plate relative to a lower plate (and possibly an upper plate). This spacing may be the result of a balance of two forces: electrostatic attraction based on voltage and charge on the
5 plate(s), and a spring constant of one or more "support structures" maintaining the position of the pixel plate away from the electrostatically charged plate. Embodiments of such devices have included Fabry-Perot device structures. In the fabrication of such devices, partially reflective surfaces may be formed, but such partially reflective surfaces may be subject to degradation of their
10 properties, either in their use environment of the devices or in the processes used to fabricate the light modulator devices. Stability of optical properties is especially important for maintaining consistent and reliable performance of Fabry-Perot devices, especially for tunable Fabry-Perot devices intended to include a "dark" or "off" state in their applications. Thus, while various light
15 modulator devices have found widespread success in their applications, there are still unmet needs in the field of micro-optical light modulator devices.

BRIEF DESCRIPTION OF THE DRAWINGS

The features and advantages of the disclosure will readily be appreciated
20 by persons skilled in the art from the following detailed description when read in conjunction with the drawings, wherein:

FIG. 1 is a cross-sectional elevation view of an embodiment of a Fabry-Perot interferometer structure.

FIG. 2 is a cross-sectional elevation view of an embodiment of a Fabry-Perot
25 interferometer structure with electrical connections shown schematically.

FIG. 3 is a flow chart of an embodiment of a method for fabricating an embodiment of a Fabry-Perot interferometer structure.

DETAILED DESCRIPTION OF EMBODIMENTS

For clarity of the description, the drawings are not drawn to a uniform scale. In particular, vertical and horizontal scales may differ from each other and may vary from one drawing to another. In this regard, directional terminology, such as "top," "bottom," "front," "back," "leading," "trailing," etc., is used with reference to the orientation of the drawing figure(s) being described. Because components of the invention can be positioned in a number of different orientations, the directional terminology is used for purposes of illustration and is in no way limiting.

10 The term "cermet" is used in the present specification and the appended claims. A cermet is a composite material composed of ceramic and metallic materials, as often used in the manufacture of components which may experience high temperatures. The metal may be used with an oxide, boride, carbide, nitride, or alumina, for example. The metallic elements used may be
15 nickel, molybdenum, and/or cobalt, for example. Other metals are included hereinbelow. Depending on the physical structure of the materials, cermets may also be formed as metal matrix composites.

One aspect of the present disclosure provides embodiments of a Fabry-Perot interferometer structure **10** as illustrated in FIGS. 1 and 2. FIG. 1 is a
20 cross-sectional elevation view of an embodiment of a Fabry-Perot interferometer structure. FIG. 2 is a cross-sectional elevation view of such an embodiment with electrical connections shown schematically.

In the Fabry-Perot embodiment shown in FIG. 1, a transparent plate **20** is spaced apart from a substrate **30** by supports **35**. Substrate **30** has at least an
25 insulating surface. Substrate **30** may also have full functionality of digital and/or analog circuitry, such as CMOS circuitry. A movable reflective pixel plate **40** is supported in the space between substrate **30** and transparent plate **20** by flexural elements **45**. An electrode **50** on substrate **30** serves as a plate of a capacitor. An optical gap **25** between transparent plate **20** and reflective pixel
30 plate **40** may be varied by applying an electrical signal to reflective pixel plate

40, which serves as another plate of the capacitor with electrode **50**. A partially reflecting layer **60** allows both partial transmission of light through transparent plate **20** and partial reflection of light reflected back from pixel plate **40**. A protective layer **70** covers and protects at least the bottom side of partially reflecting layer **60**. The structural embodiment shown in FIG. 1 may be made by employing MEMS fabrication techniques.

In FIG. 2, a voltage source **100** is shown connected between partially reflecting layer **60** and ground **110**. A second voltage source **120** is shown connected between electrode **50** and ground **110**. Thus, partially reflecting layer **60** and electrode **50** may generally be biased at different potentials. In use of the device, a modulating electrical signal is applied to movable reflective pixel plate **40** at input terminal **130**, through a transistor **140**. Resultant movement of pixel plate **40** varies optical gap **25** in accordance with the applied signal. The embodiment illustrated in FIGS. 1 and 2 provides an electronically tunable MEMS Fabry-Perot filter.

Thus, a composite partially reflecting element of a Fabry-Perot interferometer includes a transparent plate **20** having a surface facing toward the optical gap **25** of the interferometer, a partially reflecting layer **60** disposed on the surface of the transparent plate facing toward the optical gap **25**, and at least one protective layer **70** on at least one side of the partially reflecting layer. The protective layer **70** is generally not an anti-reflection layer.

A particular aspect of the disclosure provides an embodiment of a composite partially reflecting element **75** of a Fabry-Perot interferometer **10** having an optical gap. The Fabry-Perot interferometer embodiment may include a composite partially reflecting element embodiment **75** including a transparent plate having a surface facing toward the optical gap **25**, a partially reflecting layer **60** disposed on the surface of the transparent plate facing toward the optical gap, and at least one protective layer **70** on at least one side of the partially reflecting layer. The protective layer **70** may be on the side of the partially reflecting layer that faces toward the optical gap **25**, for example. Another protective layer **70** (not shown), of the same or different type, may be

disposed on the side of the partially reflecting layer that faces away from the optical gap **25**, i.e., the side facing partially reflecting layer **60**, for example.

The protective layer **70** is effective to prevent degradation of the partially reflecting layer, preserving at least the partially reflective property of the partially reflecting layer. For example, the protective layer **70** is effective to prevent degradation due to oxidation of the partially reflecting layer. It is also effective to prevent degradation due to reaction with process materials. Specifically, the protective layer is effective to prevent degradation of the composite partially reflecting element **75** due to exposure to process materials which may include a sacrificial material and a process gas used for removal of the sacrificial material. The protective layer **70** of the composite partially reflecting element **75** may also be effective as a diffusion barrier, thus preventing deleterious reactants from adversely affecting optical properties of partially reflecting layer **60**.

In specific embodiments, the composite partially reflecting element **75** may have a non-zero extinction coefficient k between about 0.2 and about 2, the value of k being substantially constant with wavelength over a desired wavelength range. The desired wavelength range may include the visible spectrum, for example, for display applications and other applications. In this or other embodiments, the composite partially reflecting element **75** may have a composite refractive index n between about 1.5 and about 4, where n increases substantially monotonically with wavelength over a desired wavelength range. Again, this desired wavelength range may include the visible spectrum. The composite refractive index n is the overall effective refractive index of the composite partially reflecting element **75** as a unit, as if the composite partially reflecting element **75** consisted of a single material of uniform refractive index n .

The partially reflecting layer **60** may include a material such as a metal, a cermet, Ag, Al, Au, Cr, Nb, Ta, Zr, the noble metals, TaAl, chromium oxide, tantalum aluminum oxide, tantalum silicon nitride, tantalum nitride, titanium nitride, alloys of these materials, or combinations of these materials. The thickness of the partially reflecting layer **60** may be between about 1 nanometer and about 50 nanometers, for example. The thickness of partially reflecting

layer **60** is chosen to produce a desired reflectance, i.e., to provide the required performance of the Fabry-Perot device. A suitable thickness for some embodiments is about 10 nanometers.

The protective layer **70** may include an oxide, nitride, or oxynitride material such as aluminum oxide, aluminum nitride, hafnium oxide, hafnium silicon oxide, tantalum aluminum nitride, tantalum aluminum oxide, silicon monoxide, silicon dioxide, silicon nitride, silicon oxynitride, silicon oxide doped with phosphorus and/or boron, titanium oxide, a tantalum oxide, zirconia, yttria, yttrium-doped zirconia, a transparent conductor such as indium tin oxide, indium oxide, tin oxide, tin oxide doped with fluorine, or various combinations of these substances. The thickness of the protective layer **70** may be between about 2 nanometers and about 25 nanometers, for example. The thickness of protective layer **70** is chosen to provide the required performance of the Fabry-Perot device while protecting partially reflecting layer **60**. This thickness may be greater than 25 nanometers for dielectric protective layers, for example, when extinction coefficient k is very low.

Thus, various embodiments of a composite partially reflecting element **75** of a Fabry-Perot interferometer have portions performing the functions of a transparent plate having a surface facing toward the optical gap, of partially reflecting light, and of protecting and preserving at least the partially reflective property.

Another aspect of the invention is an embodiment of a method including steps of providing a transparent plate, depositing a thin film of metal or cermet to form a partially reflective layer on one side of the transparent plate, and depositing over at least the partially reflective layer a protective layer effective to preserve at least the partially reflective property of the partially reflecting layer. Thus, a composite partially reflecting element **75** for a Fabry-Perot interferometer is formed. A complete Fabry-Perot interferometer including the composite partially reflecting element **75** thus formed is another aspect of embodiments described herein.

A specific embodiment of a method for a Fabry-Perot interferometer having an optical gap includes steps of (a) providing a transparent plate disposed with a surface facing toward the optical gap, (b) providing a thin film of metal or cermet to form a partially reflective layer on the surface of the transparent plate facing toward the optical gap, and (c) providing a protective layer effective to preserve at least the partially reflective property of the partially reflecting layer, whereby a protected partially reflecting composite element **75** is provided. In this specific embodiment, the materials and thicknesses of the thin film and protective layer are selected such that the composite element **75** has a non-zero extinction coefficient k between about 0.2 and about 2, the value of k being substantially constant with wavelength over a desired wavelength range. The materials and thicknesses of the thin film and protective layer are also selected such that the composite element **75** has a composite refractive index n , between about 1.5 and about 4, wherein n increases substantially monotonically with wavelength over the desired wavelength range.

FIG. 3 is a flow chart illustrating an embodiment of a method for making a light modulator. This method embodiment includes a number of steps, including providing a substrate having at least an insulating surface (step **S10**) and depositing and patterning a conductive electrode structure on the insulating surface (step **S20**). A first layer of sacrificial material is deposited (step **S30**). A first reflecting plate having a reflective surface is formed (step **S40**), and a second layer of sacrificial material is deposited (step **S50**). A protective layer effective to preserve at least the partially reflective property of a partially reflecting surface is deposited over the second layer of sacrificial material (step **S60**). A second reflecting plate having the partially reflective surface is formed (step **S70**) on the protective layer. The first and second layers of sacrificial material are removed to release at least the first reflecting plate while preserving at least the partially reflective property of the partially reflecting surface (step **S80**).

The substrate **30** may be a silicon wafer with a planar insulating surface, e.g., of silicon oxide. As mentioned above, substrate **30** may also have full functionality of digital and/or analog circuitry, such as CMOS circuitry. Other

planar insulating surfaces may be used. Conductive electrode **50** may be a film of metal deposited and patterned by photolithography, for example, on the insulating surface of substrate **30**. The reflecting plate **40**, its supports **35**, and its flexural support elements **45** may include a conductive metallic material.

5 Reflecting plate **40** and its flexural support elements **45** may be deposited and patterned on the first layer of sacrificial material. Suitable sacrificial materials for both the first and second layers of sacrificial material include amorphous silicon, polyimide, photoresist, or any of a number of other sacrificial materials such as those known to those skilled in MEMS fabrication. Each of the layers of
10 sacrificial material may be planarized after depositing the layer, e.g., by chemical-mechanical polishing (CMP). Etchants suitable for removal of each of the sacrificial materials are also known to those skilled in MEMS fabrication. Such etchants are among those process materials to be protected against by protective layer **70**.

15 The material compositions of partially reflective layer **60** and protective layer **70** respectively are described hereinabove. Protective layer **70** may be deposited by any of a number of techniques, including but not limited to sputtering, reactive sputtering, atomic layer deposition, plasma-enhanced atomic layer deposition, plasma-enhanced chemical vapor deposition, metal-
20 organic chemical vapor deposition, and anodization of deposited metallic films. Partially reflective layer **60** may also be deposited by any of these techniques or others, while controlling thickness to provide the desired relative amounts of reflection and transmission, e.g., about 50% reflection and 50% transmission. Deposition conditions for pure metals should be controlled to create relatively
25 low density films, having a degree of "dielectric character" believed to result from this low density. For example, when using sputter deposition, higher-than-usual pressures and low deposition rates (achieved by low power) tend to create such desirable low density films. Thus, the deposition conditions are controlled to provide the desired values for extinction coefficient k and for
30 effective composite refractive index n , as described in more detail hereinabove.

INDUSTRIAL APPLICABILITY

Device embodiments made in accordance with the invention are useful in display devices that have high spatial and time resolution, high brightness, and a range of colors, with low-power driving requirements. They may also be used
5 in imaging systems such as projectors and in instrumentation applications.

Although the foregoing has been a description and illustration of specific embodiments of the invention, various modifications and changes thereto can be made by persons skilled in the art without departing from the scope and spirit of the invention as defined by the following claims. For example, the reflective
10 layer, the partially reflective layer, and/or the protective layer may include multiple sublayers. Also, the order of process steps may be varied. For example, protective layer **70** may be deposited in step **S60** after removing the sacrificial layers in step **S80**, and/or step **S60** may be repeated if protective layers are used on both sides of partially reflecting layer **60**.

15 What is claimed is:

CLAIMS

1. A composite partially reflecting element of a Fabry-Perot interferometer having an optical gap, comprising:

- 5 a) a transparent plate having a surface facing toward the optical gap,
- b) a partially reflecting layer disposed on the surface of the transparent plate facing toward the optical gap, and
- c) at least one protective layer on at least one side of the partially reflecting layer.

10

2. The composite partially reflecting element of claim 1, wherein the at least one protective layer is effective to prevent degradation of the partially reflecting layer due to oxidation of the partially reflecting layer and to prevent degradation due to reaction with process materials, preserving at least the

15 partially reflective property of the partially reflecting layer.

3. The composite partially reflecting element of claim 2, wherein the process materials include a sacrificial material and a process gas used for removal of the sacrificial material.

20

4. The composite partially reflecting element of claim 1, wherein the composite element has a non-zero extinction coefficient k between about 0.2 and about 2, the value of k being substantially constant with wavelength over a desired wavelength range.

25

5. The composite partially reflecting element of claim 1, wherein the composite element has a composite refractive index n between about 1.5 and about 4, and wherein n increases substantially monotonically with wavelength over a desired wavelength range.

5

6. The composite partially reflecting element of any of claims 4 or 5, wherein the desired wavelength range includes the visible spectrum.

7. The composite partially reflecting element of any of claims 1 - 6,
10 wherein the at least one protective layer comprises an oxide, nitride, or oxynitride material selected from the list consisting of aluminum oxide, aluminum nitride, hafnium oxide, hafnium silicon oxide, tantalum aluminum nitride, tantalum aluminum oxide, silicon monoxide, silicon dioxide, silicon nitride, silicon oxynitride, silicon oxide doped with phosphorus and/or boron,
15 titanium oxide, a tantalum oxide, zirconia, yttria, yttrium-doped zirconia, a transparent conductor, indium tin oxide, indium oxide, tin oxide, tin oxide doped with fluorine, and combinations thereof.

8. A method comprising steps of:

20

a) providing a transparent plate,

b) depositing a thin film of metal or cermet to form a partially reflective layer on one side of the transparent plate, and

c) depositing over at least the partially reflective layer a protective layer effective to preserve at least the partially reflective property of the partially
25 reflecting layer, whereby a composite partially reflecting element for a Fabry-Perot interferometer is formed.

9. A method for a Fabry-Perot interferometer having an optical gap, the method comprising steps of:

a) providing a transparent plate disposed with a surface facing toward the optical gap,

5 b) providing a thin film of metal or cermet to form a partially reflective layer on the surface of the transparent plate facing toward the optical gap, and

c) providing a protective layer effective to preserve at least the partially reflective property of the partially reflecting layer, whereby a protected partially reflecting composite element is provided, the materials and thicknesses of the
10 thin film and protective layer being selected such that the composite element has a non-zero extinction coefficient k between about 0.2 and about 2, k being substantially constant with wavelength over a desired wavelength range and such that the composite element has a composite refractive index n , between about 1.5 and about 4, wherein n increases substantially monotonically with
15 wavelength over the desired wavelength range.

10. A method for making a light modulator, comprising:

a) providing a substrate having at least an insulating surface,

20 b) depositing and patterning a conductive electrode structure on the insulating surface,

c) depositing a first layer of sacrificial material,

d) forming a first reflecting plate having a reflective surface,

e) depositing a second layer of sacrificial material,

f) depositing over the second layer of sacrificial material a protective layer
25 effective to preserve at least the partially reflective property of a partially reflecting surface,

g) forming a second reflecting plate having the partially reflective surface,
and

h) removing the first and second layers of sacrificial material to release at least the first reflecting plate while preserving at least the partially reflective property of the partially reflecting surface.

1/2

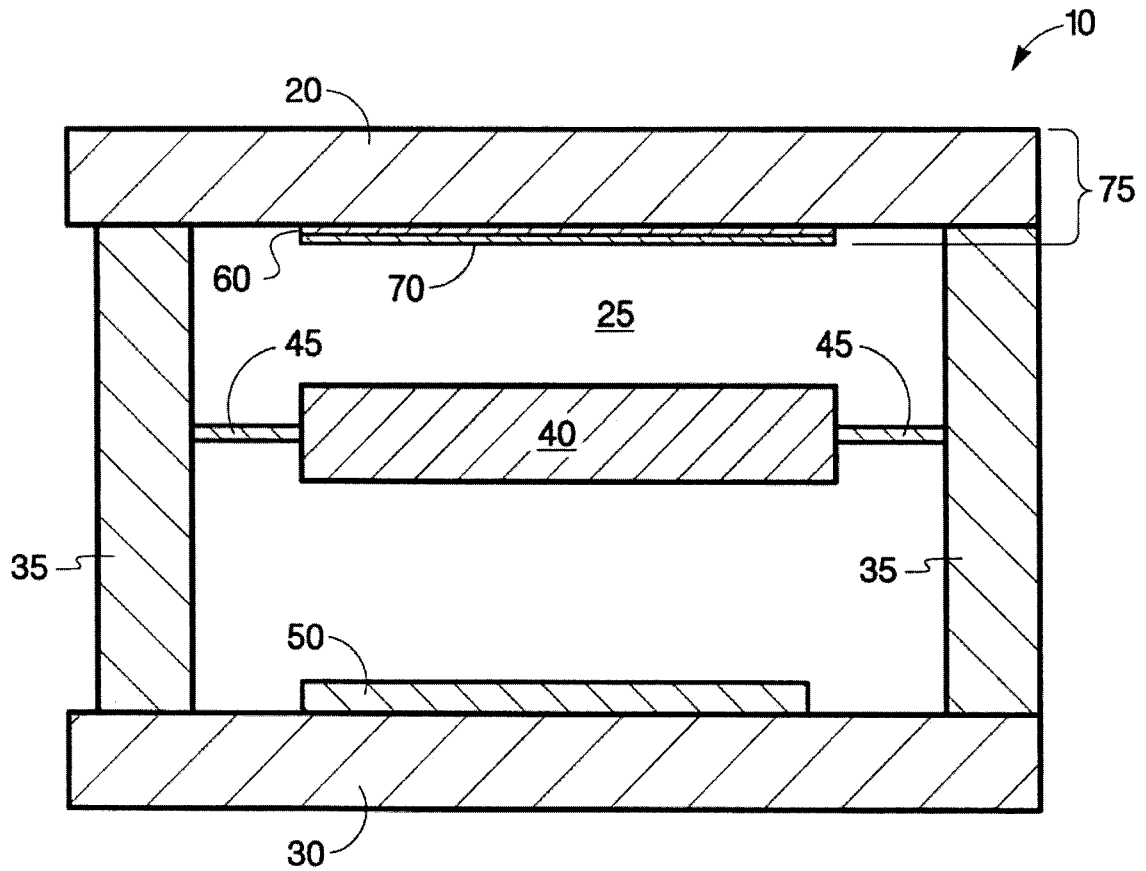

Fig. 1

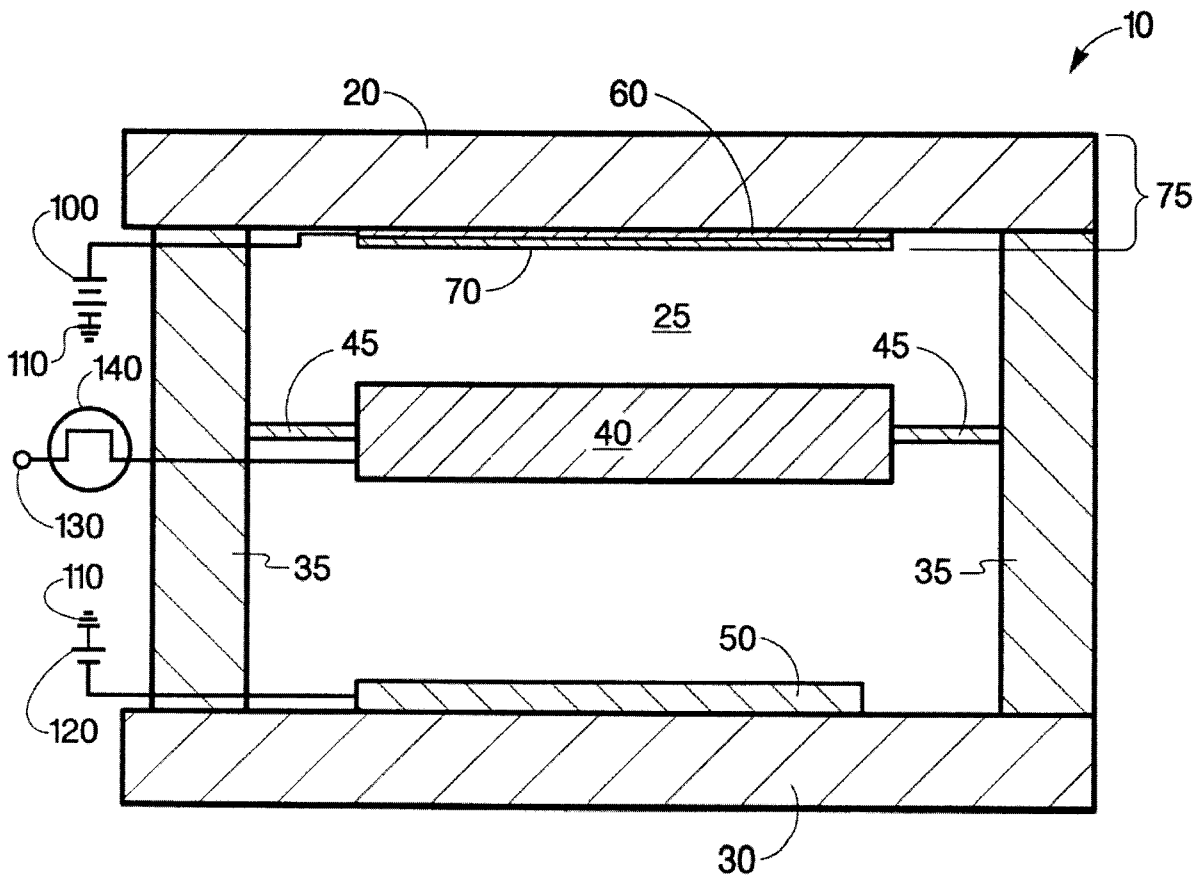

Fig. 2

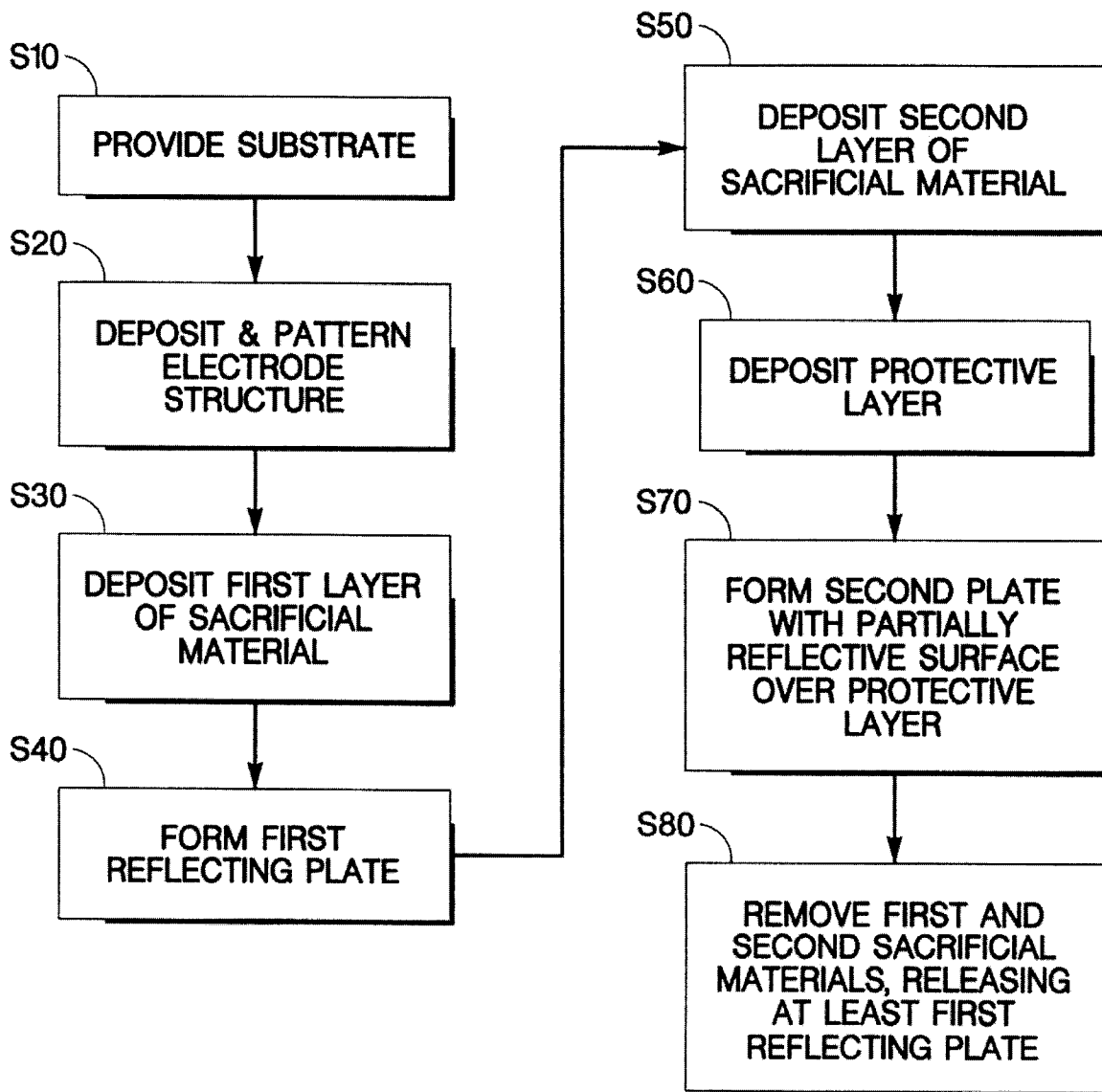

Fig. 3