

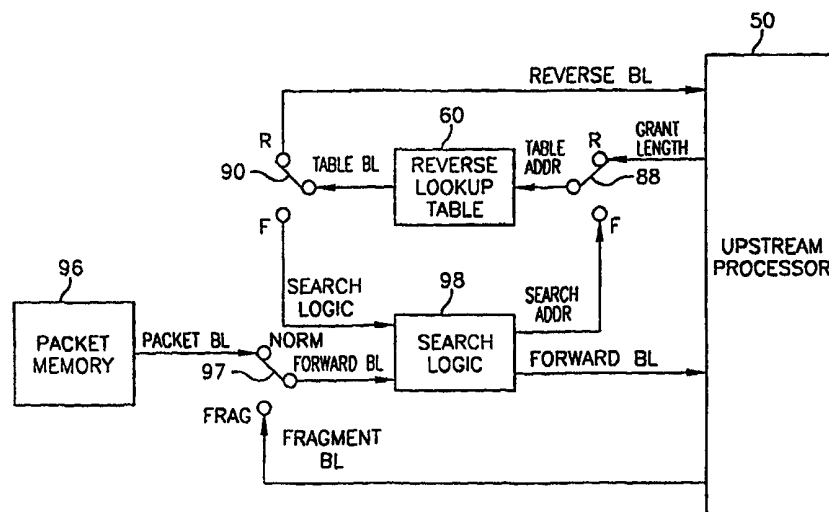

## INTERNATIONAL APPLICATION PUBLISHED UNDER THE PATENT COOPERATION TREATY (PCT)

<p>(51) International Patent Classification : <b>Not classified</b></p>	<p><b>A2</b></p>	<p>(11) International Publication Number: <b>WO 00/41511</b></p> <p>(43) International Publication Date: 20 July 2000 (20.07.00)</p>
<p>(21) International Application Number: PCT/US00/01091</p> <p>(22) International Filing Date: 14 January 2000 (14.01.00)</p> <p>(30) Priority Data: 60/115,998 15 January 1999 (15.01.99) US 09/430,821 29 October 1999 (29.10.99) US</p> <p>(71) Applicant (for all designated States except US): BROADCOM CORPORATION [US/US]; P.O. Box 57013, Irvine, CA 92619-7013 (US).</p> <p>(72) Inventors; and (75) Inventors/Applicants (for US only): HORTON, John, D., Jr. [US/US]; 11590 Windbrooke Way, Alpharetta, GA 30005 (US). HOLLUMS, Scott [US/US]; 3926 Whitney Park Drive, Duluth, GA 30096 (US). ROUSSEL, Chris [US/US]; 325 Destiny Trace, Alpharetta, GA 30004 (US).</p> <p>(74) Agent: RAHN, LeRoy, T.; Christie, Parker &amp; Hale, LLP, P.O. Box 7068, Pasadena, CA 91109-7068 (US).</p>		<p>(81) Designated States: AE, AL, AM, AT, AU, AZ, BA, BB, BG, BR, BY, CA, CH, CN, CR, CU, CZ, DE, DK, DM, EE, ES, FI, GB, GD, GE, GH, GM, HR, HU, ID, IL, IN, IS, JP, KE, KG, KP, KR, KZ, LC, LK, LR, LS, LT, LU, LV, MA, MD, MG, MK, MN, MW, MX, NO, NZ, PL, PT, RO, RU, SD, SE, SG, SI, SK, SL, TJ, TM, TR, TT, TZ, UA, UG, US, UZ, VN, YU, ZA, ZW, ARIPO patent (GH, GM, KE, LS, MW, SD, SL, SZ, TZ, UG, ZW), Eurasian patent (AM, AZ, BY, KG, KZ, MD, RU, TJ, TM), European patent (AT, BE, CH, CY, DE, DK, ES, FI, FR, GB, GR, IE, IT, LU, MC, NL, PT, SE), OAPI patent (BF, BJ, CF, CG, CI, CM, GA, GN, GW, ML, MR, NE, SN, TD, TG).</p> <p><b>Published</b> <i>Without international search report and to be republished upon receipt of that report.</i></p>

(54) Title: METHOD AND APPARATUS FOR CONVERTING BETWEEN BYTE LENGTHS AND BURDENED BURST LENGTHS IN A HIGH SPEED CABLE MODEM



## (57) Abstract

Requests are processed to transmit data packets upstream from a cable modem to a cable headend in a manner that minimizes the use of CPU operations and/or memory capacity. Data packets to be transmitted upstream are stored at the cable modem. The data packets each have a given transmission data byte length value. Burst profiles are received successively at the cable modem. Each time a new burst profile is received, a set of physical data length values corresponding to respective transmission data byte length values is calculated from the parameters of the received burst profile. The calculated set of physical data length values is stored in memory so the individual values can be retrieved from the transmission data byte length values again and again, rather than being re-calculated each time a conversion is made from transmission data byte length values to physical data length values. The same set of physical data length values is used until a new burst profile is received by the cable modem.

**FOR THE PURPOSES OF INFORMATION ONLY**

Codes used to identify States party to the PCT on the front pages of pamphlets publishing international applications under the PCT.

AL	Albania	ES	Spain	LS	Lesotho	SI	Slovenia
AM	Armenia	FI	Finland	LT	Lithuania	SK	Slovakia
AT	Austria	FR	France	LU	Luxembourg	SN	Senegal
AU	Australia	GA	Gabon	LV	Latvia	SZ	Swaziland
AZ	Azerbaijan	GB	United Kingdom	MC	Monaco	TD	Chad
BA	Bosnia and Herzegovina	GE	Georgia	MD	Republic of Moldova	TG	Togo
BB	Barbados	GH	Ghana	MG	Madagascar	TJ	Tajikistan
BE	Belgium	GN	Guinea	MK	The former Yugoslav Republic of Macedonia	TM	Turkmenistan
BF	Burkina Faso	GR	Greece			TR	Turkey
BG	Bulgaria	HU	Hungary	ML	Mali	TT	Trinidad and Tobago
BJ	Benin	IE	Ireland	MN	Mongolia	UA	Ukraine
BR	Brazil	IL	Israel	MR	Mauritania	UG	Uganda
BY	Belarus	IS	Iceland	MW	Malawi	US	United States of America
CA	Canada	IT	Italy	MX	Mexico	UZ	Uzbekistan
CF	Central African Republic	JP	Japan	NE	Niger	VN	Viet Nam
CG	Congo	KE	Kenya	NL	Netherlands	YU	Yugoslavia
CH	Switzerland	KG	Kyrgyzstan	NO	Norway	ZW	Zimbabwe
CI	Côte d'Ivoire	KP	Democratic People's Republic of Korea	NZ	New Zealand		
CM	Cameroon			PL	Poland		
CN	China	KR	Republic of Korea	PT	Portugal		
CU	Cuba	KZ	Kazakstan	RO	Romania		
CZ	Czech Republic	LC	Saint Lucia	RU	Russian Federation		
DE	Germany	LI	Liechtenstein	SD	Sudan		
DK	Denmark	LK	Sri Lanka	SE	Sweden		
EE	Estonia	LR	Liberia	SG	Singapore		

1  
METHOD AND APPARATUS FOR CONVERTING BETWEEN BYTE LENGTHS AND  
BURDENED BURST LENGTHS IN A HIGH SPEED CABLE MODEM

5 BACKGROUND OF THE INVENTION

This invention relates to data over cable transmission and, more particularly, to a method and apparatus for generating requests to transmit data packets upstream from a cable modem to a cable headend.

10 To coordinate upstream data transmission from a number of cable modems to a headend in a cable transmission system so there is no collision among a number of cable modems using the same channel, the cable modems send request messages to the headend that tell the headend the amount of bandwidth needed to transmit the data. The bandwidth expressed in minislots is sometimes referred to as the physical length (PHY L) of the data to be transmitted. The PHY L required to transmit a data packet having a given byte length (BL) varies depending upon the  
15 overhead imposed by the physical layer of the cable system, such as the preamble, guard band, forward error correction, and padding. The parameters that determine the overhead are part of a burst profile transmitted to each cable modem through uniform channel descriptor (UCD) messages. When a request to transmit data is made by a modem, the BL of the data packet to be transmitted is converted to the PHY L by calculations based on a formula including the  
20 parameters. When a grant message is returned to the requesting modem, it tells the requesting modem which minislots to use for upstream transmission of the data packet.

25 If the cable transmission system is capable of fragmented data transmission, i.e., transmitting a data packet in two or more fragments, the grant message sent from the headend to the requesting cable modem includes the PHY L of the data segment to be transmitted in the allotted bandwidth. Before transmitting this data fragment, its PHY L must be converted to a BL value. This conversion is also made by calculations based on the formula including the parameters.

30 SUMMARY OF THE INVENTION

35 According to the invention, requests are generated to transmit data packets upstream from a cable modem to a cable headend in a manner that minimizes the use of CPU operations and/or memory capacity. Data packets to be transmitted upstream are stored at the cable modem. The data packets each have a given transmission byte length value. Successive burst profiles are received from time to time at the cable modem. Each time a new burst profile is received, a set of physical data length values corresponding to respective transmission byte length values is calculated from the parameters of the received burst profile. The calculated set of physical data length values is stored in memory so the individual physical data length values can be retrieved

1 from the transmission byte length values again and again, rather than being re-calculated each  
time a conversion is made from transmission byte length values to physical data length values.  
The same set of physical data length values is used until a new burst profile is received by the  
5 cable modem.

Preferably, the calculated set of physical data length values is stored in a forward lookup  
table so the respective transmission byte length values represent the addresses to the physical  
data length values in the forward lookup table and the data length conversion can be  
accomplished by simply addressing the forward lookup table.

10 If data packets are transmitted in fragmented form, a calculated set of transmission byte  
length values is preferably stored in a reverse lookup table so respective physical data length  
values represent the addresses to the transmission byte length values in the reverse lookup table  
and the transmission byte length conversion can be accomplished by simply addressing the  
reverse lookup table. In this case, the physical data length conversion can either be carried out  
15 with a forward lookup table or an iterative search of the reverse lookup table that compares  
retrieved transmission byte values with the desired value in order to find the physical data length.

#### DESCRIPTION OF THE DRAWINGS

The features of specific embodiments of the best mode contemplated of carrying out the  
20 invention are illustrated in the drawings, in which:

FIG. 1 is a schematic diagram of a cable transmission system including a headend with  
a cable modem termination system connected by a hybrid fiber coaxial (HFC) network to a  
plurality of cable modems;

25 FIG. 2 is a schematic diagram of the headend and a cable modem in one home of the cable  
transmission system;

FIG. 3 is a schematic diagram of the cable modem of FIG. 2 in more detail;

FIGGS. 4A and 4B are diagrams of a forward lookup table and a reverse lookup table used  
to practice the invention;

30 FIG. 5 is a flow diagram of the process for requesting the allocation of time slots to  
transmit data packets from a cable modem to the headend;

FIG. 6 is diagram of a single lookup table arranged to convert between transmission data  
byte and physical data length in both the forward and reverse directions;

FIG. 7 is a flow diagram showing the operation of a state machine for performing a binary  
search of the single table of FIG. 6;

35 FIG. 8 is a schematic block diagram of circuitry for executing the flow diagram of FIG.  
7;

T  
FIG. 9, 10, and 11 are schematic diagrams of another environment, namely, a wireless transmission system, in which the invention can be practiced.

5  
DETAILED DESCRIPTION OF THE SPECIFIC EMBODIMENTS

In a cable modem system, a headend or cable modem termination system (CMTS) is located at a cable company facility and functions as a modem which services a large number subscribers. Each subscriber has a cable modem (CM). Thus, the cable modem termination system must be capable of facilitating bidirectional communication with any desired one of the plurality of cable modems.

10  
As used herein, the cable modem termination system (CMTS) is defined to include that portion of a headend which effects communication with a plurality of cable modems. A typical cable modem termination system includes a burst receiver, a continuous transmitter and a medium access control (MAC).

15  
The cable modem termination system communicates with the plurality of cable modems via a hybrid fiber coaxial (HFC) network, wherein optical fiber provides communication to a plurality of fiber nodes and each fiber node typically serves approximately 500 to 2,000 subscribers. These subscribers communicate with the node via a shared coaxial cable. It is this sharing of the common coaxial cable which necessitates that the number of cable modems attached thereto be limited so as to mitigate the likelihood of undesirable bit rate reductions which inherently occur when an excessive number of cable modems communicate simultaneously over a single coaxial cable.

20  
The hybrid fiber coaxial network of a cable modem system utilizes a point-to-multipoint topology to carry out communication between the cable modem termination system and the plurality of cable modems. Frequency domain multiple access (FDMA)/time division multiplexing (TDM) is used to facilitate communication from the cable modem termination system to each of the cable modems, i.e., in the downstream direction. Frequency domain multiple access (FDMA)/time domain multiple access (TDMA) is used to facilitate communication from each cable modem to the cable modem termination system, i.e., in the upstream direction.

25  
The cable modem termination system includes a downstream modulator for facilitating the transmission of data communications therefrom to the cable modems and an upstream demodulator for facilitating the reception of data communications from the cable modems.

30  
Typically, the downstream modulator of the cable modem termination system utilizes either 64 QAM or 256 QAM in a frequency band of 54 MHz to 860 MHz to provide a data rate of up to 56 Mbps. Since the upstream channel has a much lower data rate requirement, the

1 upstream demodulator typically uses either QPSK or 16 QAM in a frequency range of 5 MHz to 42 MHz to provide a data rate of up to 10 Mbps.

5 The asymmetric data throughput defined by the upstream channel requiring a much lower data rate than the downstream channel results from the inherently larger amount of data which is communicated via the downstream channel during pay-per-view, Internet access and the like, wherein a video signal is communicated via the downstream channel, while only control signals such as those associated with viewing of the video signal are communicated via the upstream channel. Thus, the downstream channel requirement may exceed 1.5 Mbps, while the upstream  
10 channel requirement may be as low as 16 Kbps.

In the future, it is expected that cable transmission in the upstream direction will become broader band, because digital television transmission requires less bandwidth than analog television transmission.

15 Each cable modem includes an upstream modulator for facilitating the transmission of data to the cable modem termination system and a downstream demodulator for receiving data from the cable modem termination system. The upstream modulator of each cable modem uses either QPSK or 16 QAM within the 5 MHz to 42 MHz bandwidth of the upstream demodulator and the downstream demodulator of each cable modem utilizes either 64 QAM or 256 QAM in the 54 MHz to 860 MHz bandwidth of the downstream modulator (in North America).

20 Contemporary cable modem systems operate on a plurality of upstream channels and utilize time division multiple access (TDMA) in order to facilitate communication between a plurality of cable modems and a single cable modem termination system on each upstream channel. Typically, between 250 and 500 cable modems communicate with a single cable modem termination system on a given upstream channel.

25 In order to accomplish TDMA for upstream communication, it is necessary to assign time slots within which cable modems having a message to send to the cable modem termination system are allowed to transmit. The assignment of such time slots is accomplished by providing a request contention area in the upstream data path within which the cable modems are permitted to contend in order to place a message which requests additional time in the upstream data path for the transmission of their message. (Small data packets are sometimes also transmitted in  
30 contention regions.) The cable modem termination system responds to these requests by assigning time slots to the cable modems making such a request, so that as many of the cable modems as possible may transmit their messages to the cable modem termination system utilizing TDMA and so that the transmissions are performed without undesirable collisions.

35 Because of the use of TDMA, the cable modem termination system must use a burst receiver, rather than a continuous receiver, to receive data packets from cable modems via upstream communications. As those skilled in the art will appreciate, a continuous receiver can

1 only be utilized where generally continuous communications (as opposed to burst  
communications as in the present invention) are performed, so as to substantially maintain timing  
synchronization between the transmitter and the receiver, as is necessary for proper reception of  
5 the communicated information. During continuous communications, timing recovery is a more  
straightforward process since signal acquisition generally only occurs at the initiation of such  
communications. Thus, acquisition is generally only performed in continuous receivers once per  
continuous transmission and each continuous transmission may be very long.

10 However, the burst communications inherent to TDMA systems require periodic and  
frequent reacquisition of the signal. That is, during TDMA communications, the signal must be  
reacquired for each separate burst transmission being received.

15 Since continuous receivers generally only acquire the signal once, the need to minimize  
acquisition time is much less critical in continuous receivers than in burst receivers, wherein  
acquisition must be performed for each separate burst, and therefore occurs quite frequently.  
Thus, there is a strong motivation to minimize acquisition time in burst receivers, so as to  
enhance overall data transmission efficiency and throughput. As such, it is beneficial to provide  
techniques which enhance the speed at which data packets transmitted according to TDMA  
methodologies may be acquired by a burst receiver, such as that of a cable modem termination  
system.

20 Referring now to FIG. 1, a hybrid fiber coaxial (HFC) network 10 transmits data between  
a headend 12, which includes at least one cable modem termination system, and a plurality of  
homes 14, each of which contains a cable modem. Such hybrid fiber coaxial networks are  
commonly utilized by cable providers to provide Internet access, cable television, pay-per-view  
and the like to subscribers.

25 Approximately 500 homes 14 are in electrical communication with each node 16, 34 of  
the hybrid fiber coaxial network 10, typically via coaxial cable 29, 30, 31. Amplifiers 15  
facilitate the electrical connection of the more distant homes 14 to the nodes 16, 34 by boosting  
the strength of the electrical signals so as to desirably enhance the signal-to-noise ratio of such  
communications and by then transmitting the electrical signals over coaxial conductors 30, 31.  
30 Coaxial conductors 29 electrically interconnect the homes 14 with the coaxial conductors 30, 31,  
which extend between amplifiers 15 and nodes 16, 34.

Each node 16, 34 is electrically connected to a hub 22, 24, typically via an optical fiber  
28, 32. The hubs 22, 24 are in communication with the headend 12, via optical fiber 20, 26.  
Each hub is typically capable communicating with approximately 20,000 of homes 14.

35 The optical fiber 20, 26 extending intermediate the headend 12 and each hub 22, 24  
defines a fiber ring which is typically capable of communicating between approximately 100,000  
of homes 14 and the headend 12.

1  
5  
The headend 12 may include video servers, satellite receivers, video modulators, telephone switches and/or Internet routers 18, as well as the cable modem termination system. The headend 12 communicates via transmission line 13, which may be a T1 or T2 line, with the Internet, other headends and/or any other desired device(s) or network.

Referring now to FIG. 2, a simplified block diagram shows the interconnection of the headend 12 and an exemplary home 14, wherein a cable modem 46 communicates with a cable modem termination system at headend 12, embodied as a line card 42, via hybrid fiber coaxial network (HFC) 10.

10  
More particularly, a personal computer 48, disposed within the home 14, is connected via cable 11 to the cable modem 46 which communicates via coaxial cable 17 with the hybrid fiber coaxial network 10. Network 10 in turn communicates via optical fiber 20 with the line card or cable modem termination system (CMTS) 42 of the headend 12. Internet router 40 permits communication between the headend 12 and the Internet or any other desired device or network.

15  
As shown in FIG. 3, each cable modem 46 has an upstream processor 50 coupled to the upstream channels of network 10 and a downstream processor 52 coupled to the downstream channels of network 10. Upstream processor 50 sends, among other things, time slot request messages and ranging and station maintenance request messages on an assigned one of the upstream channels of HFC network 10. Downstream receiver 52 intercepts, among other things,  
20 bandwidth allocation MAP messages that include minislot grant messages and also intercepts upstream channel descriptor (UCD) messages that include burst profiles carried on the downstream channels of HFC network 10. A central processing unit (CPU) 54 is coupled to upstream processor 50 and downstream receiver 52. CPU 54 has a random access memory (RAM) 56 that can be rapidly accessed by CPU 54 because it is preferably on the same integrated circuit chip as CPU 54. For this reason RAM 56 usually has limited storage capacity. CPU 54  
25 is also coupled to an external memory 57 that can only be accessed slowly because it is off chip. External memory 57 usually has a large storage capacity and serves other functions and components in the cable modem. By way of example, external memory 57 could be a SDRAM. A lookup table described in more detail below is stored in RAM 56. Preferably, upstream  
30 processor 50, downstream receiver 52, CPU 54, including a memory controller for interfacing with External memory 57, and RAM 56 are all resident on a single integrated circuit chip and external memory 57 is external to the single chip. Data packets representing information to be transmitted on an upstream channel are stored in external memory 57. CPU 54 sends the time slot request messages for the data packets stored in External memory 57 and couples such  
35 messages to upstream processor 50 to be sent on an assigned channel to a cable modem termination system (CMTS) at the cable headend. From time to time CPU 54 also sends commands to upstream processor 50 to transmit ranging and station maintenance requests on



I  
the assigned upstream channel. A time slot request message includes a field that contains the  
number of minislots in the assigned upstream channel required to transmit a particular data packet  
or part of a data packet, including the overhead imposed by the physical layer of the cable system  
such as preamble, guard band, forward error correction (FEC), and padding. The byte length of  
5 the data packet to be transmitted, is designated BL herein. The number of minislots required to  
transmit this data packet burdened with the overhead imposed by the physical layer of the system  
composed of the preamble, guard band, forward error correction (FEC), padding, etc. in terms of  
minislots is called physical length herein (PHY L). PHY L can be calculated from the BL based  
10 on the parameters of the burst profile. At initialization of a cable modem and from time to time  
as determined by the cable operator, the CMTS sends a burst profile downstream, including the  
parameters that permit calculation of PHY L from BL. The CMTS also sends bandwidth  
allocation MAPS including time slot grant messages to downstream processor 52 when the cable  
modems request bandwidth to transmit data packets.

15 In a first mode of operation, the system is only capable of sending the entire data packet at  
one time in a contiguous group of minislots. In a second mode of operation, the system is also  
capable of fragmenting a data packet and sending the data packet in two or more groups of  
minislots at different times, as described further below. In the first mode of operation, a grant  
message is not sent by the CMTS until a sufficient number of minislots are available to send the  
20 entire data packet, i.e., the PHY L of the entire data packet. In this mode of operation, when a grant  
message is received, the entire data packet is sent to upstream processor for upstream transmission  
with a standard preamble and other message components. In the second mode of operation, there  
are two ways fragmentation takes place when the granted PHY L is less than the PHY L of the data  
packet to be transmitted—piggybacking and multiple grants. According to the first way, a portion  
25 of the data packet is sent to upstream processor 50 for upstream transmission piggybacked with a  
field that indicates the physical length of the remainder of the data packet to be transmitted as a  
further request. According to the second way, multiple grant messages are sent to a requesting cable  
modem allocating separate multiple time slots. In either case, to determine the BL of the fragment  
of the data packet transmitted, the BL must be calculated from the PHY L, based on the parameters  
30 of the burst profile.

Reference is made to Application No. 09/430,821 filed October 29, 1999 for a further  
description of the the process for transmitting data packets on an upstream channel and for  
fragmenting the data packets.

35 Because it would require complex hardware to carry out the conversion between the BL  
values and the PHY L values and these values do not change often, i.e., only when the burst profiles  
are changed, they are calculated by firmware in CPU 54 and stored in one or more tables until the  
burst profiles are changed.

1  
5  
10  
15  
20  
25  
30  
35

In the first mode of operation, rather than calculating the PHY L each time that a time slot request message is generated, the values of PHY L corresponding to all values of BL are generated and stored in a forward lookup table in RAM 56. Each time that a new burst profile is received by downstream receiver 52, the PHY L values are re-calculated and the previously stored forward lookup table is replaced with a new updated table comprising the re-calculated PHY L values. Between receipt of new burst profiles the PHY L values are derived directly from the forward lookup table for use each time that a BL value is converted to a PHY L value for insertion in a time slot request message. As a result, expensive hardware is not needed to calculate the PHY L values, CPU 54 is not burdened each time that a BL to PHY L conversion needs to be made, and the conversion can be made without the delay encountered in calculating the PHY L value each time a conversion is made.

In the second mode of operation, the BL values are calculated from PHY L and stored in a reverse lookup table in RAM 56 to eliminate the need for expensive hardware to calculate the BL values, reduce the processing burden on CPU 54, and speed the conversion of PHY L values to BL values.

FIG. 4 depicts a forward lookup table 58 and a reverse lookup table 60 stored in RAM 56 to make the conversions described above. Forward lookup table 58 comprises a number of memory locations in RAM 56 having contiguous addresses in which the PHY L values are stored. Typically, the value of PHY L is represented by an eight bit word, resulting in 256 values of PHY L so an eight bit word is stored in each memory location. Typically, in an Internet application, BL can have up to 1454 bytes and varies consecutively from 64 to 1518. For this exemplary number of BL values, forward lookup table 58 has 1454 entries. (In other applications the BL can have from one to up to 8K bytes and the table must be sized accordingly.) A number of the entries are duplicative because there are more BL values than PHY L values. The index into forward lookup table 58 is the offset from the beginning of the table. If a table begins at address zero, the PHY L for BL having a value of 64 is at address 64.

Reverse lookup table 60 comprises a number of memory locations in RAM 56 having contiguous addresses; the BL values are stored in these memory locations and the PHY L values serve as the addresses to access these BL values. Reverse lookup table 58 has 256 entries, i.e., one entry for each PHY L address, and the value of BL stored in each memory cell is represented by a sixteen bit word to accommodate the maximum number of BL values. Because there are more BL values than PHY L values, the BL values stored in memory locations with adjacent addresses are not consecutive; the stored BL value in each memory location is the largest BL that will accommodate the corresponding PHY L.

Hardware in processors 50 and 52 executes the operations for processing requests to transmit data packets upstream from a cable modem to the cable headend. Alternatively, these operations

1 could be executed by firmware in CPU 54 which is part of the MAC. The tradeoff is time and CPU  
burden against hardware cost. These operations are illustrated in FIG. 5. As represented by a block  
62, the hardware initiates a command, including a BL value, to generate a request message to  
5 transmit a data packet. As represented by a block 64, forward lookup table 58 (FIG. 4) is used by  
the hardware to convert the BL value to a PHY L value. As represented by a block 68, the PHY L  
value is inserted by the hardware into the request message. As represented by a block 68, the  
request message, including the PHY L value, is transmitted on the assigned upstream channel by  
Upstream processor 50 (FIG. 3). As represented by a block 70, Downstream receiver 52 (FIG. 3)  
10 receives a grant message including the PHY L value of the minislots allocated to the cable modem  
to transmit the data packet. As represented by a block 72, the PHY L value is extracted from the  
grant message by the hardware. As represented by a decision block 74, the grant message is  
examined by the hardware to determine whether it is a partial grant or a full grant. This  
determination is made by comparing the original requested PHY L value with the PHY L value  
15 extracted from the grant message. If the requested PHY L is greater than the granted PHY L,  
fragmentation is carried out. If the message identifies a full grant, the N path is followed from  
block 74 to a block 76, according to which the entire data packet stored in RAM 56 of CPU 54 is  
transmitted on the assigned upstream channel by Upstream processor 50. (In the first mode of  
operation there is a direct path from block 72 to block 76 since no partial grants are executed.)

20 If the message identifies a partial grant, the Y path is followed from block 74 to a block 78,  
according to which a PHY L value is converted to a BL value by reverse table 60 (FIG. 4) under  
control of the hardware. As represented by a block 80, the BL value derived in block 78 is  
subtracted by the hardware from the BL value of the entire data packet to form a difference BL  
value. As represented by a block 82, the difference BL value is converted by forward lookup table  
25 58 to a difference PHY L value under control of the hardware. As represented by a block 84, the  
difference BL value is also used to select a partial data packet to be transmitted on the assigned  
upstream channel by Upstream processor 50 in the minislots allocated by the grant message  
received pursuant to block 70. The partial data packet transmitted pursuant to block 84 is  
accompanied by a further mini-slot request in the form of the difference PHY L value to transmit  
30 the remainder of the data packet. As represented by a block 86, the operations of block 70 and the  
blocks that follow are repeated until the entire data packet has been transmitted.

In one embodiment, both the forward and reverse conversions are carried out with a single  
lookup table to reduce the amount of RAM 56 required to carry out these conversions. Preferably,  
reverse lookup table 60 is used because it requires less memory space than forward lookup table 58  
35 (in the above example, 256 bytes). Reverse lookup table 60 is used in the manner described above  
to convert PHY L to BL by directly addressing reverse lookup table 60 with PHY L as an address  
to access the BL value stored in the corresponding memory location of the table. An iterative search

1  
5  
10  
15  
20  
25  
30  
35

procedure, preferable a binary search, is used to convert from BL to PHY L; specifically, different PHY L values are iteratively applied to reverse lookup table 60 to find the BL value closest to the BL value to be converted, i.e., the desired BL value. The resulting address is the corresponding PHY L value.

FIG. 6 functionally illustrates how reverse lookup table 60 operates to carry out the conversion in both directions. A switch 88 is connected to the address input of reverse lookup table 60 and the output of reverse lookup table 60 is connected to a switch 90. Switches 88 and 90 are controlled by hardware, depending on whether a forward request or a reverse request is made to lookup table 60. When a grant message is received by upstream processor 50 (FIG. 3), a PHY L value is extracted from the grant message, switch 88 assumes a state R to connect upstream processor 50 to the address input of table 60, and switch 90 assumes a state R to connect the output of table 60 back to upstream processor 50. As a result, in this mode PHY L values are converted to BL values by directly accessing table 60 with a PHY L value as an address in the manner described above in connection with FIG. 4 and the BL values from reverse table 60 are subtracted from the BL values of the data packets being transmitted.

When a time slot request is initiated, requiring a conversion from a BL value to a PHY L value, the hardware feeds a BL value from a packet memory 96, which is part of external memory 57, through a fragmentation switch 97 to a first input of a search logic circuit 98, the operation of which is described below in connection with FIG. 7. Switch 97 is in a normal state. In this mode, switch 88 in a state F couples the output of search logic 98 to the address input of reverse lookup table 60 and switch 90 in a state F couples the output of reverse lookup table 60 to a second input of search logic circuit 96. Search logic circuit 96 feeds the correct PHY L value to upstream processor 50.

When a data packet is to be fragmented, switch 97 assumes a fragment state and the BL value of the fragment is coupled from upstream processor 50 through switch 97 to search logic circuit 98 for conversion to a PHY L value.

The binary search regiment imposed by search logic circuit 96 when reverse lookup table 60 performs the conversion from BL to PHY L is illustrated in FIG. 7. It is assumed that table 60 is divided into two parts. Successive 16-bit BL values are stored in memory locations of the two parts that have the same address. Both parts are addressed simultaneously to speed up the search process. Two successive BL values are retrieved in response to an applied address. State machine 96 first applies an address, i.e., a PHY L value, at the middle of the two part table. The corresponding BL values in table 60 are looked up, as represented by a block 100. As represented by a decision block 102, a comparison between the desired BL and the lookup BLs is made. If the desired BL lies between the lookup BLs or is equal to one of the BLs, namely, the even BL, the Y path is followed to latch the applied address, i.e., the PHY L value, as represented by a block 104.

1  
If the desired BL does not lie between the lookup BLs, the N path is followed to a decision block  
106. In connection with block 106, a determination is made as to whether the desired BL is larger  
than the lookup BLs. If the desired BL is larger than the lookup BLs, the Y path is followed to a  
5  
block 108, which causes an upward shift in the applied address and a return to block 100. If the  
desired BL is not larger than the lookup BLs, the N path is followed to a block 110, which causes  
a downward shift in the applied address and a return to block 100. In each case the shift is to the  
middle of the remainder of the unsearched table. This process is repeated until the desired BL lies  
between the lookup BLs or is equal to the even lookup BL.

10  
The logic circuitry for performing the binary search is illustrated in more detail in FIG. 8.  
For purposes of illustration it is assumed that there are 256 consecutive 16-bit words stored in  
reverse table 60 in monotonically increasing value of BL. Reverse table 60 is subdivided into an  
even table 60a and an odd table 60b to speed up the search operation. Through a CPU interface 102  
are loaded into table 60 such that consecutive table entries are mapped to alternative locations in  
15  
even table 60a and odd table 60b, i.e., table entries 0, 2, 4, 6, ..., 254 are mapped to locations 0, 1,  
2, 3, ..., 128 of even table 60a and table entries 1, 3, 5, 7, ..., 255 are mapped to locations 0, 1, 2, 3, ...,  
128 of odd table 60b. Thus, when a particular table entry is addressed, the odd value is larger than  
the even value. The conversion of a BL value to a PHY L value is initiated by a lookup request  
applied to a control finite state machine (FSM) 104 by the hardware. The output of an adjust  
20  
register (ADJUST REG) 106 and the output of an address register (ADDR REG) 108 are added or  
subtracted at a junction 110. The output of ADDR REG 108 is also applied to the address inputs  
of tables 60a and 60b and to output PHY L register 98. The output of junction 110 is applied to an  
input of a multiplexer 111. The highest address in the table, i.e., FFh, is applied to another input  
of multiplexer 111. The BL from packet memory 96, hereafter called the "desired BL", and the  
25  
output of table 60a are applied to comparator 112. Comparator 112 sends a binary "1" to FSM 104  
if the output of table 60a is larger than or equal to the desired BL and a binary "0" to FSM 104 if  
the output of table 60a is smaller than the desired BL. The desired BL and the output of RAM 60b  
are applied to a comparator 114. Comparator 114 sends a binary "1" to FSM 104 if the output of  
table 60b is larger than or equal to the desired BL and a binary "0" to FSM 104 if the output of  
30  
table 60b is smaller than the desired BL. Junction 110 adds or subtracts the outputs of ADJUST  
REG 106 and ADDR REG 108, depending upon the binary values sent to FSM 104 by comparators  
112 and 114. If the binary values are both "1", the contents of ADJUST REG 106 and ADDR REG  
108 are added and the value stored in ADJUST REG 106 is divided by two. If the binary values  
are both "0", the contents of ADJUST REG 106 is subtracted from the contents of ADDR REG  
35  
108, and ADDR REG 108 are added and the value stored in ADJUST REG 106 is divided by two.  
If the binary value sent to FSM 104 by comparator 112 is "1" and the binary value sent to FSM 104

1 by comparator 114 is "0". FSM sends a command to output register 98 to latch the PHY L value stored therein and sends a lookup acknowledge signal to the hardware.

5 When table 60a and 60b are accessed by the search logic, the address of both tables comes from ADDR REG 108. Both RAMs in which the tables are stored are forced to the read mode. The address in this case is a word address between 0 and 128. ADDR REG 108. is eight bits, but the LSB is not used to address the RAMs. The LSB is sent to OUTPUT REG 98. There are two ways to complete the search. One is to find  $BL \leq \text{EVEN}$  and not  $BL \leq \text{ODD}$  as shown in FIG. 8. The other is to make eight iterations. ADJUST REG register 106 starts out with a value of 0x80. It is shifted right each iteration through the search taking on values of 0x40, 0x20, 0x10, 0x08, 0x04, 0x02, 0x01, and finally 0x00. If the adjust register gets to 0x00 (i.e. the eighth iteration), then the search concludes and the current eight bit value in ADDR REG 108 is latched in OUTPUT REG. 98. This is the case anytime the desired PHY L is odd.

15 In summary, the address in register 108 initially points to the middle of tables 60a and 60b. If the desired BL is less than the lookup values, the address in ADDR REG 108 is shifted by the value stored in ADJUST REG 106 so it points at the middle of the bottom half of the table and visa versa. If the desired BL is less than the look up values in bottom half of the table, the address in ADDR REG 108 is shifted again by the value in ADJUST REG 106 so it points at the middle of the bottom quarter of the table and visa versa. Successively smaller values are loaded into ADJUST REG 106 until the desired BL lies between the lookup values or is equal to the larger of the lookup values.

20 Reference is made to FIGS. 9 and 10 for a description of another embodiment of the invention. In this embodiment, there are wireless transmission links between homes 14 and HFC network 42. Each of homes 14 is equipped with radio frequency modem (RFM) 2000. A base station 2002 is in wireless RF contact with RFM's 2000. The wireless architecture is similar to a cellular phone system. Code division multiple access (CDMA) transmission could be used between RFM's 2000 and base station 2002. Base station 2002 is connected by a fiber 2004 to a CMTS hub 2006. Hub 2006 is part of HFC network 42. Otherwise the components in FIGS. 9 and 10 are the same, and bear the same reference numerals, as those described in connection with FIGS. 1 and 2. As illustrated in FIG. 9, CMTS hub 2006 can be integrated in the same cable system that also services CM's connected by fiber to hub 22. Thus, upstream and/or downstream channels can be installed in a home without physically laying cable all the way to the home. If desired, the downstream channel could be fiber because of the large bandwidth requirement, and the upstream channel could be wireless because there is a smaller bandwidth requirement.

35 The described functions of cable modems 46 could be carried out on a single integrated circuit chip as illustrated in FIG. 11. In this chip the output of an RF transmitter 3000 feeds the upstream channels of HFC network 42. The downstream channels of HFC network 42 feed the

1

input of an RF receiver 3002. A time division multiple access (TDMA) controller 3004 is connected to the input of transmitter 3000. The output of receiver 3002 is connected to TDMA controller 3004. An ethernet 3006 serves as an interface between TDMA controller 3004 and a PC or other binary signal processing device. TDMA controller 3004 could be an application specific circuit or a microprocessor programmed to perform the described CMTS functions, including fragmentation.

5

10

The described embodiment of the invention is only considered to be preferred and illustrative of the inventive concept; the scope of the invention is not to be restricted to such embodiment. Various and numerous other arrangements may be devised by one skilled in the art without departing from the spirit and scope of this invention. For example, the forward lookup table could be used as the single table in processing fragmented data packets if it is not important in the particular application to conserve memory space.

15

20

25

30

35

## WHAT IS CLAIMED IS:

1. A method for processing requests to transmit data packets upstream from a cable modem to a cable headend, the method comprising the steps of:
- receiving burst profiles successively at the cable modem;
  - storing a data packet to be transmitted upstream, the data packet having a given transmission data byte length value;
  - calculating a set of physical data length values corresponding to respective transmission data byte length values each time that a new burst profile is received;
  - storing the calculated set of physical data length values in memory so they can be retrieved from the transmission data byte length values each time that a new burst profile is received to replace a previously calculated set of physical data length values;
  - retrieving the physical data length value corresponding to the given transmission data byte length value from the stored set; and
  - transmitting from the cable modem a request message that includes the retrieved physical data length value.
2. The method of claim 1, additionally comprising the steps of:
- storing a plurality of successive data packets to be transmitted upstream;
  - retrieving the physical data length values corresponding to the transmission data length values of the successive data packets from a single stored set in memory; and
  - transmitting from the cable modem successive request messages that include the respective retrieved physical data length values.
3. The method of claim 2, additionally comprising the steps of:
- replacing the calculated set of physical data length values in memory with a new set when a new burst profile is received;
  - retrieving the physical data length values corresponding to the transmission data length values from the new stored set; and
  - transmitting from the cable modem a request message that includes the retrieved physical data length value corresponding to the given transmission data byte length value from the new stored set.
4. The method of claim 1, additionally comprising the steps of:
- receiving from the headend a grant message to transmit the stored data packet in a designated upstream time slot; and



1 transmitting the stored data packet to the headend in the designated time slot responsive to the grant message.

5 5. The method of claim 4, in which the step of receiving a grant message receives a grant message to transmit only part of the stored data packet, the grant message containing a physical length value for the part of the stored data packet to be transmitted.

6. The method of claim 5, additionally comprising the steps of:

10 calculating a set of transmission data length values corresponding to respective physical data length values each time that a new burst profile is received;

storing the calculated set of transmission data length values in memory so they can be retrieved from the physical data length values each time that a new burst profile is received to replace a previously calculated set of physical data length values;

15 retrieving from the stored set the transmission data length value corresponding to the given physical data length value contained in the grant message;

determining the difference between the given transmission data byte length value and the transmission data length value corresponding to the given physical data length value contained in the grant message;

20 retrieving from the stored set of physical data length values as a remainder data length value the physical data length value corresponding to the difference between the given transmission data byte length value and the transmission data length value corresponding to the given physical data length value contained in the grant message; and

25 transmitting from the cable modem a request message that includes the remainder data length value.

7. A cable modem comprising:

an upstream transmitter for sending out signal bursts;

a downstream receiver for recovering burst profiles in response to the signal bursts;

30 means for storing a data packet to be transmitted upstream, the data packet having a given transmission data byte length value;

means for calculating a set of physical data length values corresponding to respective transmission data byte length values each time that a new burst profile is recovered by the downstream receiver;

35 means for storing the calculated set of physical data length values in memory so they can be retrieved from the transmission data byte length values each time that a new burst profile is received to replace a previously calculated set of physical data length values;

- 1 means for retrieving the physical data length value corresponding to the given transmission data byte length value from the stored set;
- means for generating a time slot request message that includes the retrieved physical data length value; and
- 5 means for coupling the request message to the upstream transmitter to send out the retrieved physical data length value.
8. The cable modem of claim 7, in which the downstream receiver intercepts a grant message to transmit the stored data packet in a designated upstream time slot and the upstream transmitter sends the stored data packet to the headend in the designated time slot responsive to the grant message.
- 10
9. The cable modem of claim 8, in which the storing means stores the calculated set of physical data length values in a forward table so the respective transmission data byte length values represent the addresses to the physical data length values in the forward table and the retrieving means addresses the forward table with the given transmission data byte length value to retrieve the physical data length value corresponding to the given transmission data byte length value.
- 15
10. The cable modem of claim 9, in which the downstream receiver intercepts a grant message to transmit only part of the stored data packet, the grant message containing a physical length value for the part of the stored data packet to be transmitted.
- 20
11. The cable modem of claim 10, in which the storing means also stores the transmission data byte length values in a reverse table so the respective physical data length values represent the addresses to the transmission data byte length values in the reverse table and the retrieving means addresses the reverse table with the physical length value for the part of the stored data packet to be transmitted. to retrieve the corresponding transmission data length value.
- 25
12. The cable modem of claim 8, in which the storing means stores the calculated set of physical data length values in a reverse table so the respective physical data length values represent the addresses to the transmission data byte length values in the reverse table, the retrieving means addresses the reverse table with the physical length value for the part of the stored data packet to be transmitted. to retrieve the corresponding transmission data length value, and the retrieving means searches the addresses of the reverse table to find the address closest to the given transmission data byte length value to use as the physical data length value in the time slot request message.
- 30
- 35

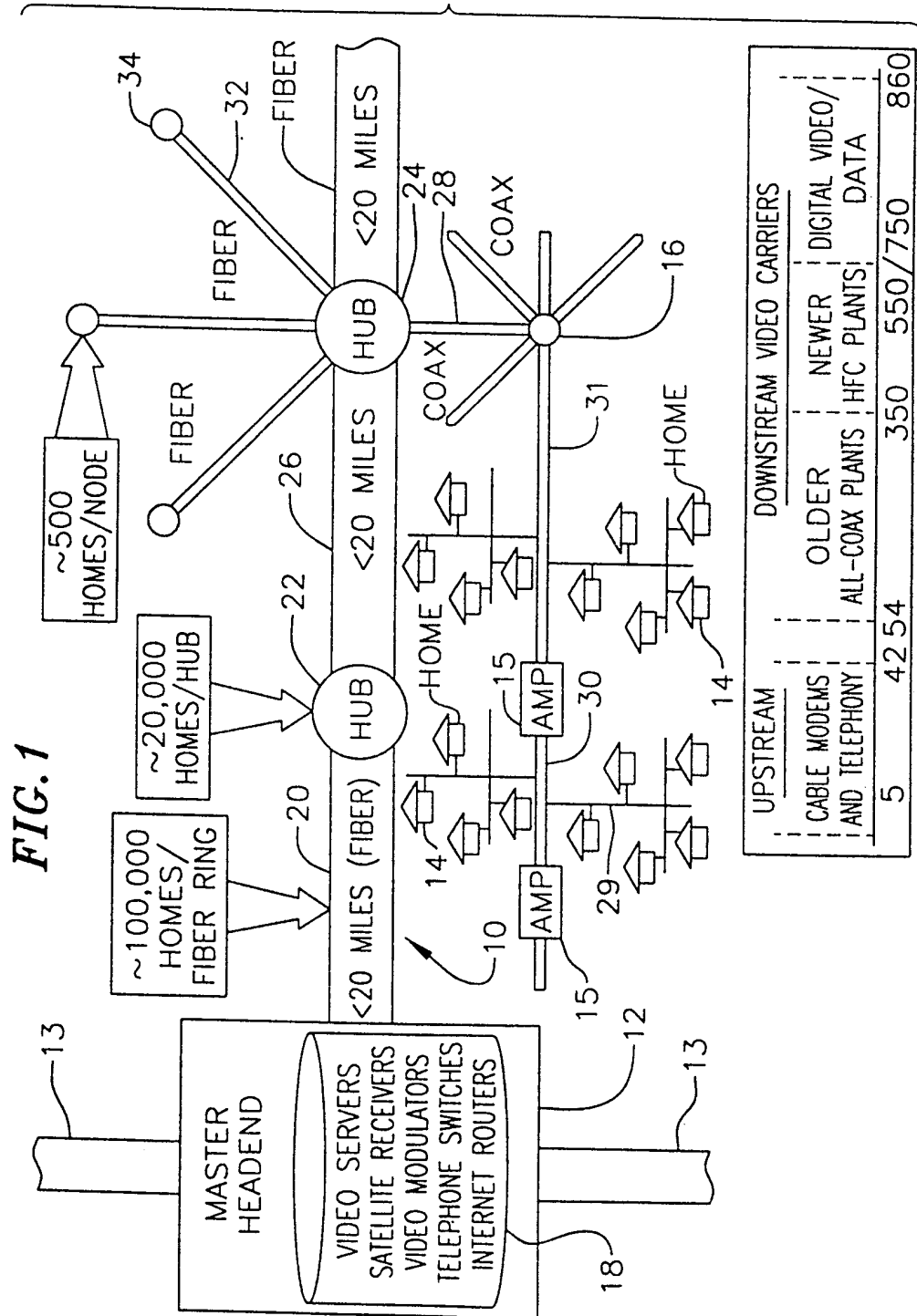

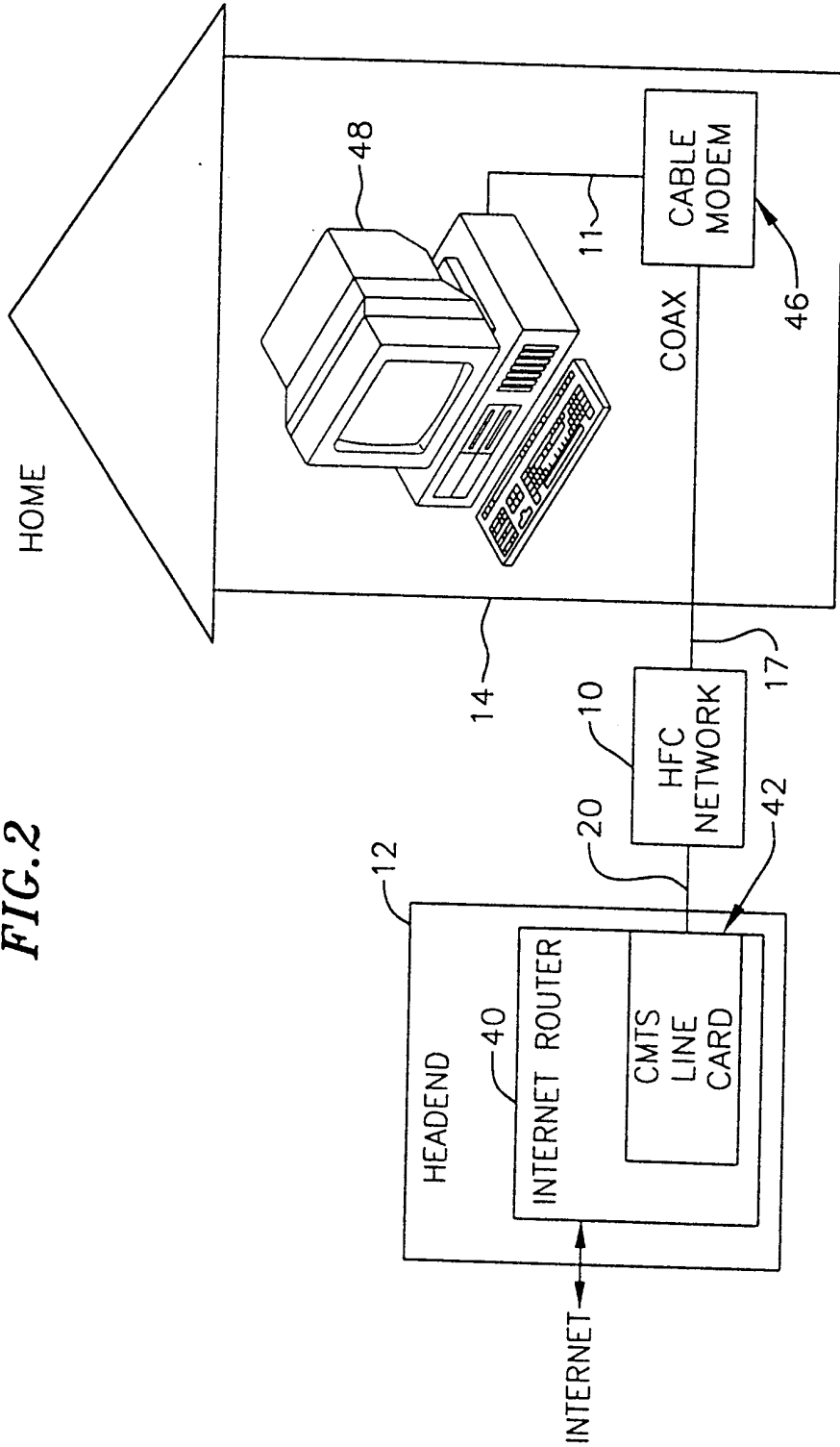
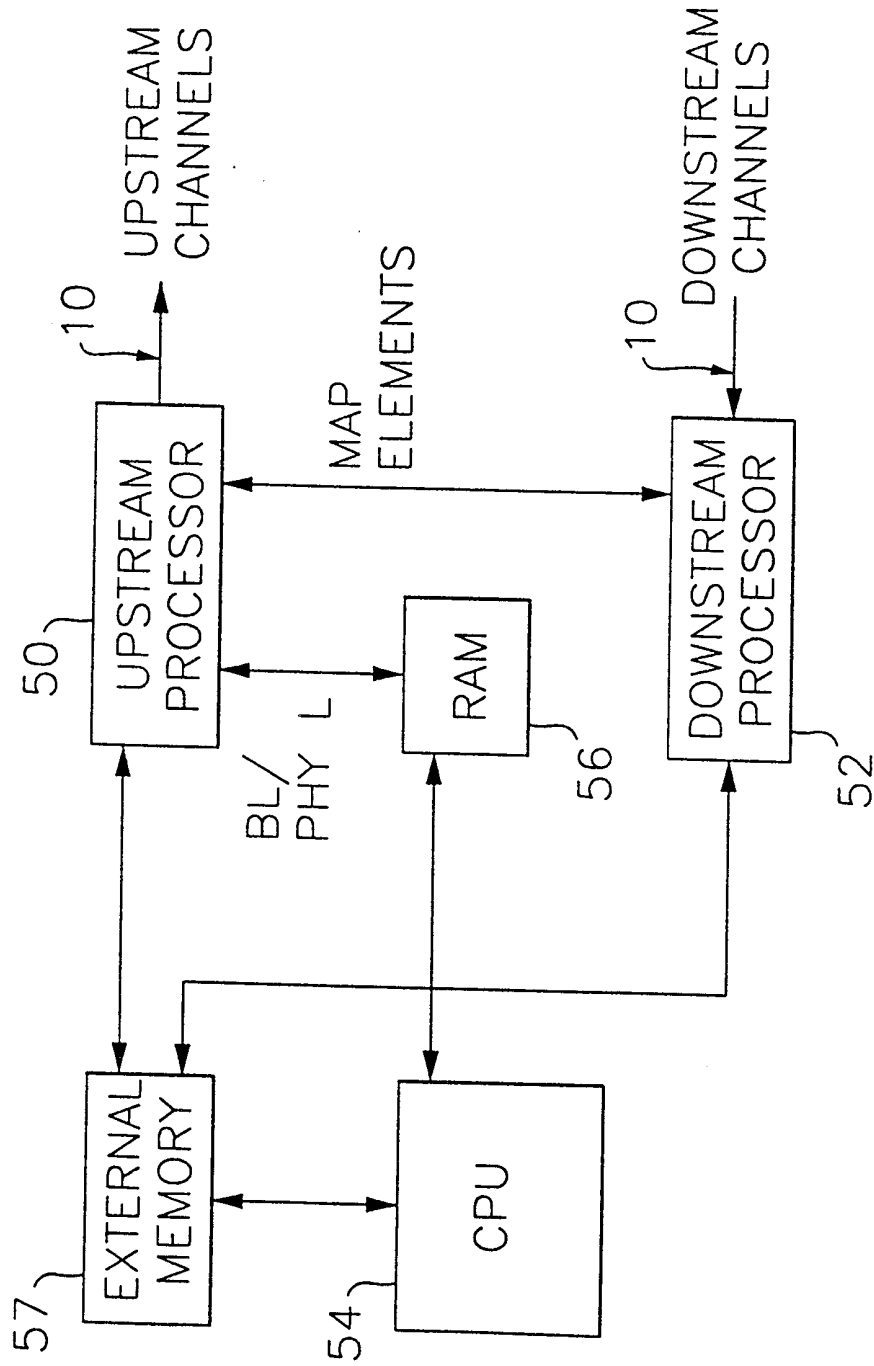
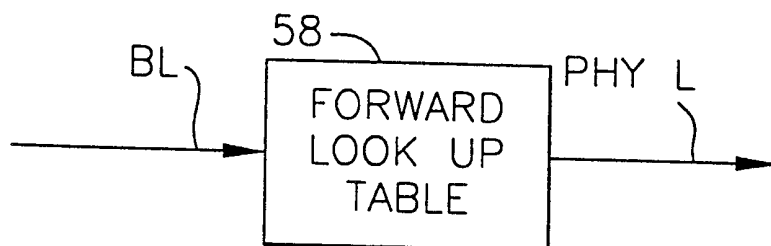

FIG. 2

FIG. 3



*FIG. 4A*



*FIG. 4B*

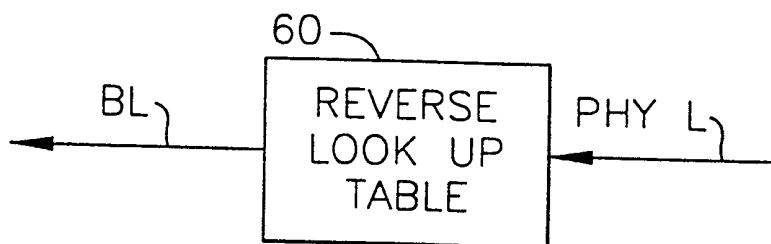
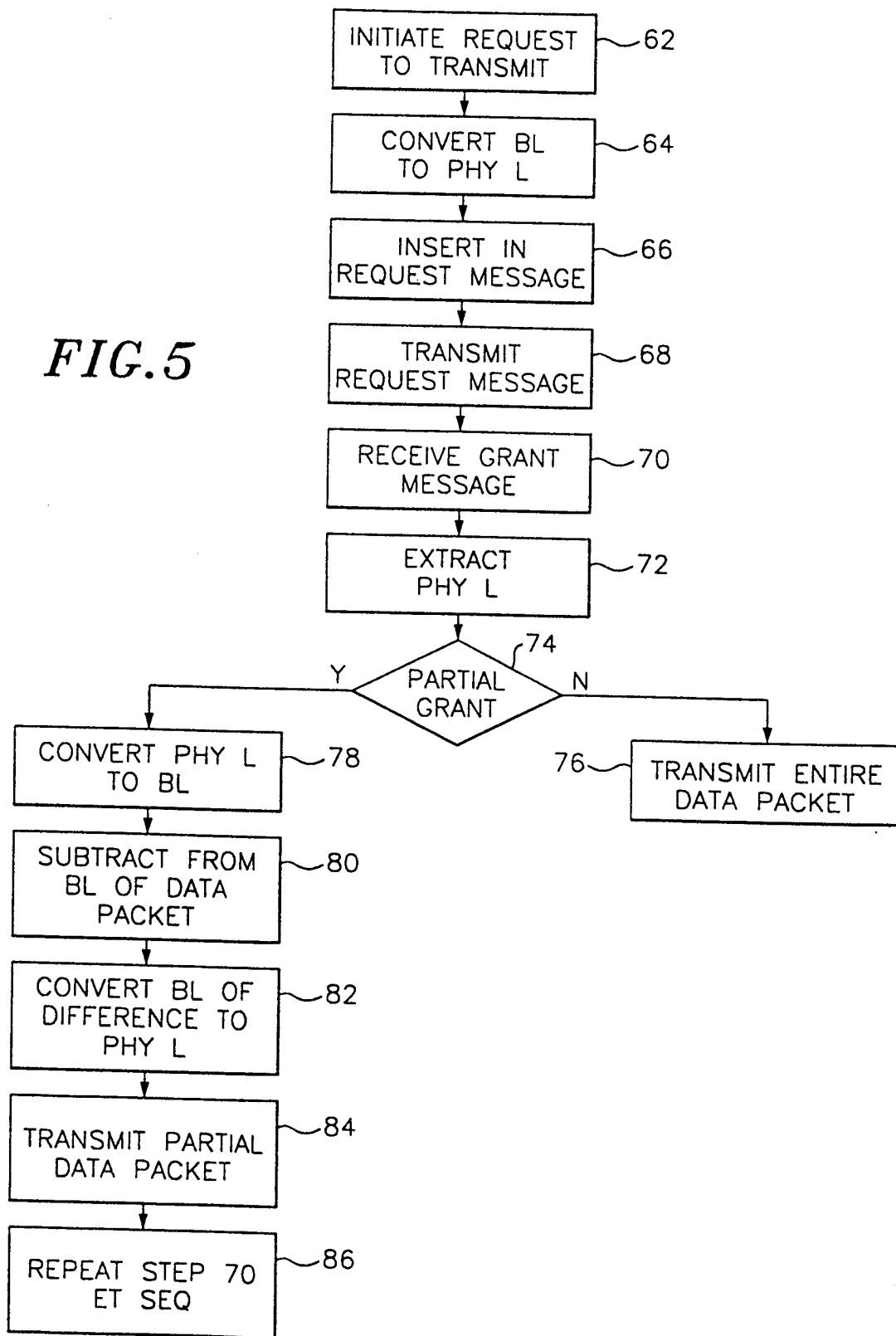

FIG. 5



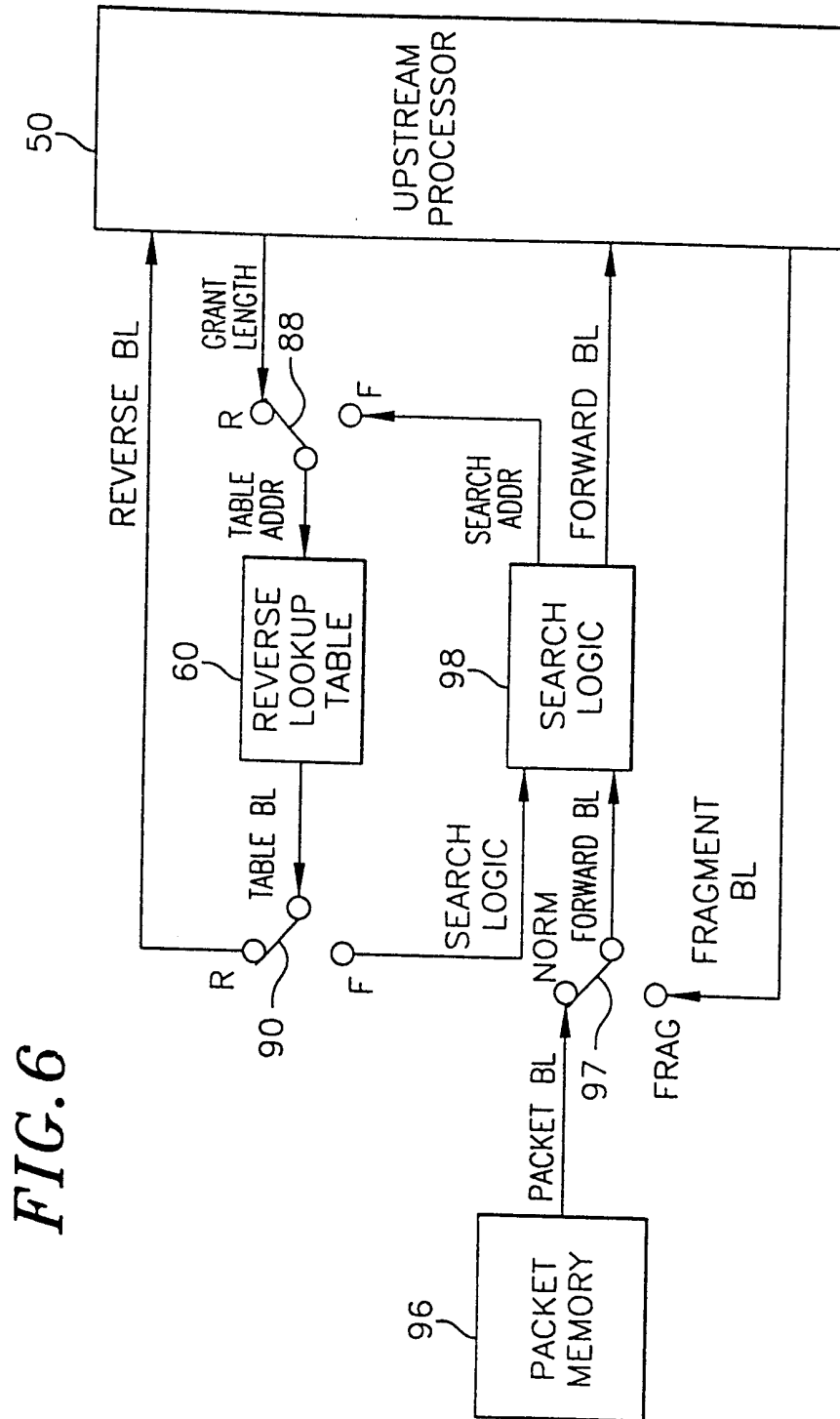

FIG. 6



FIG. 7

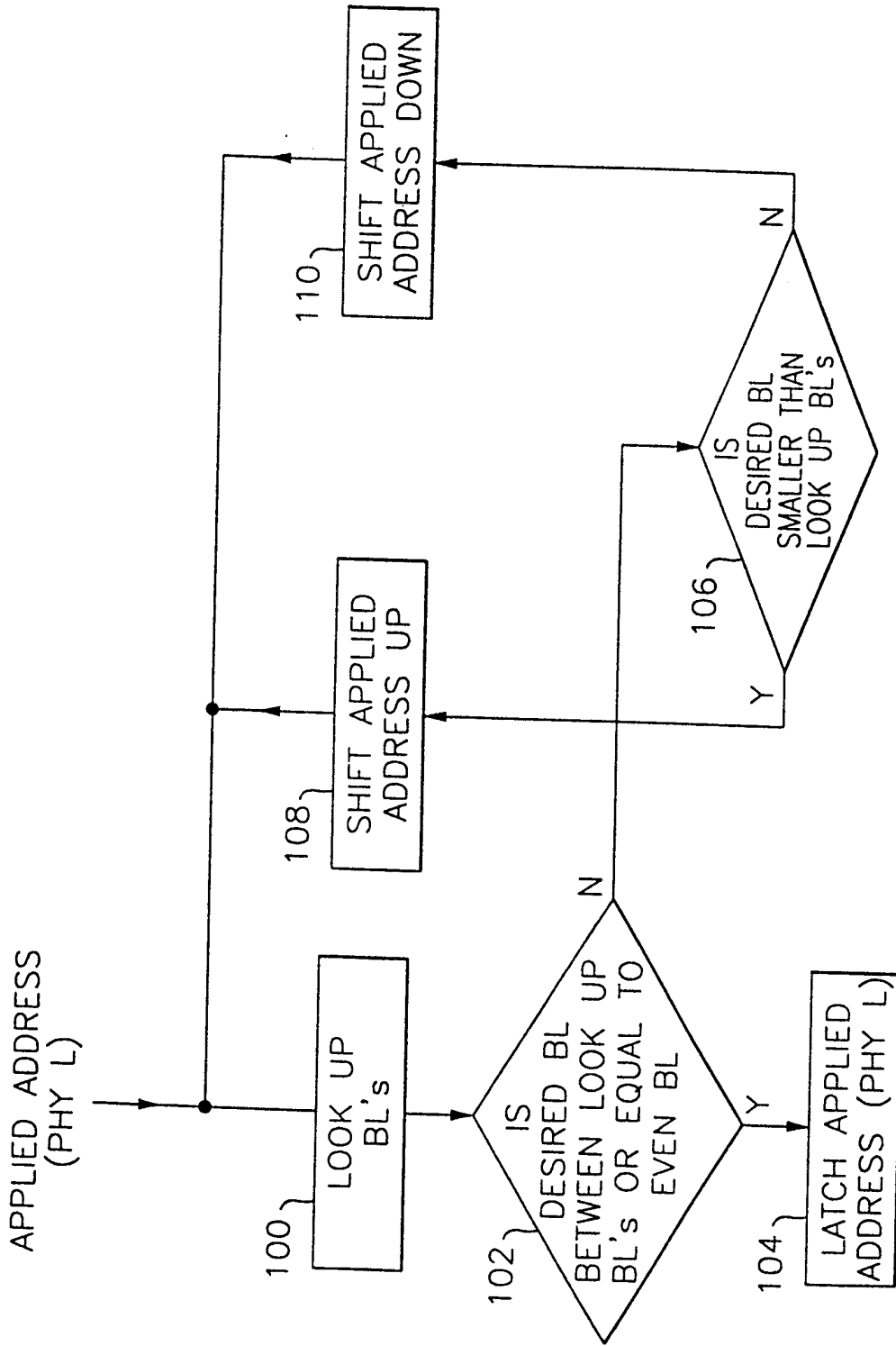

FIG. 8

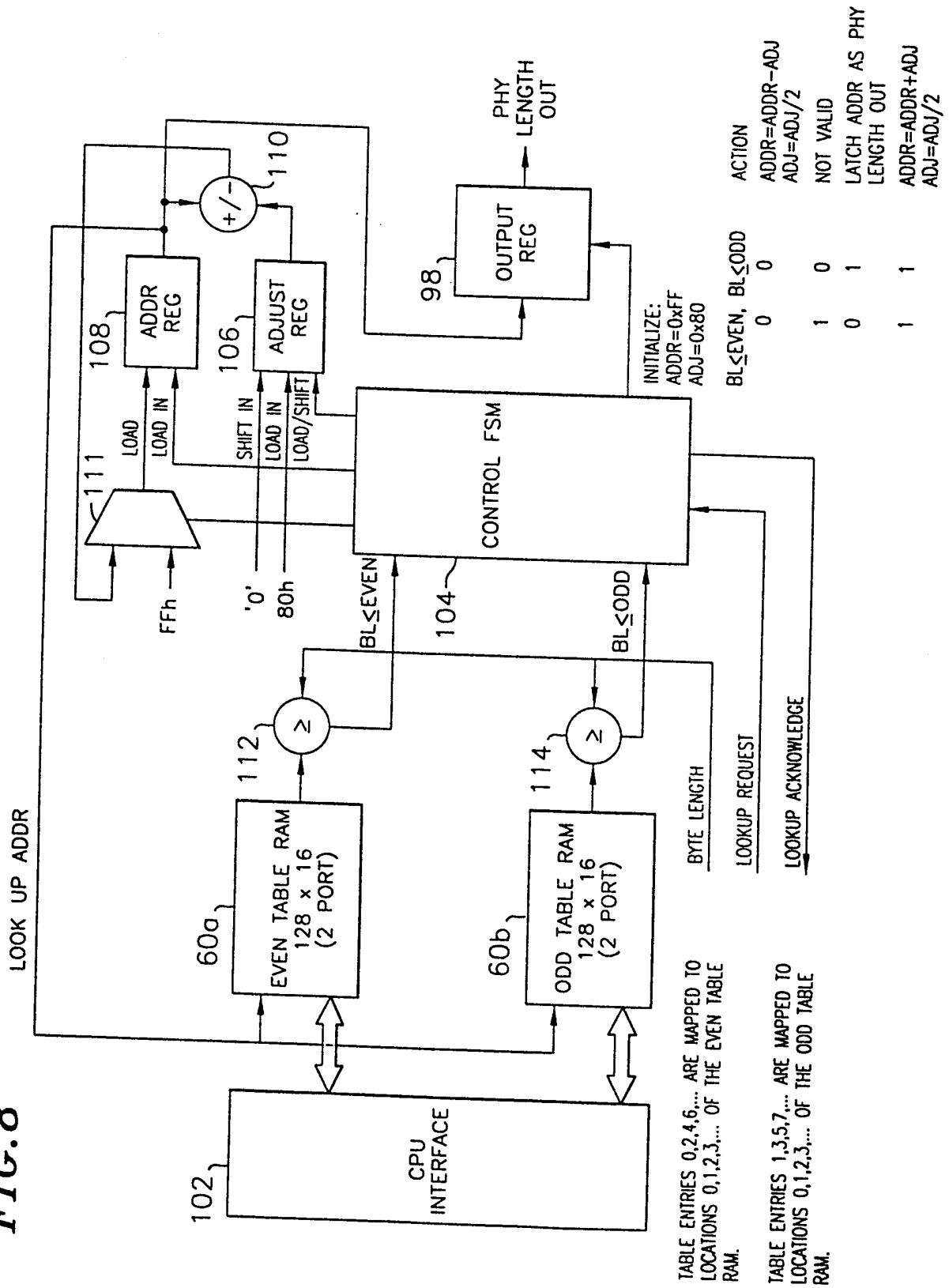

FIG. 9

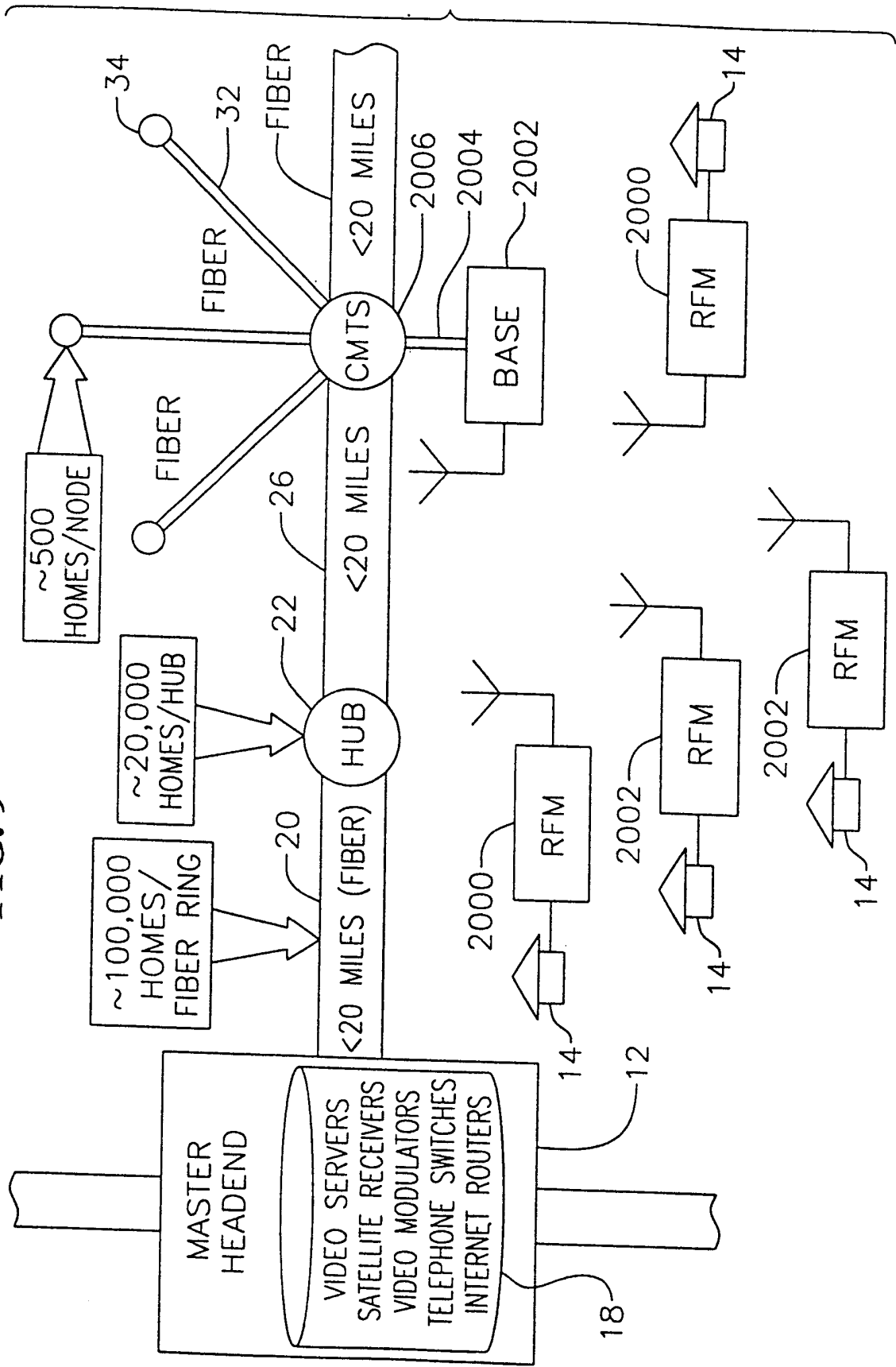

FIG. 10

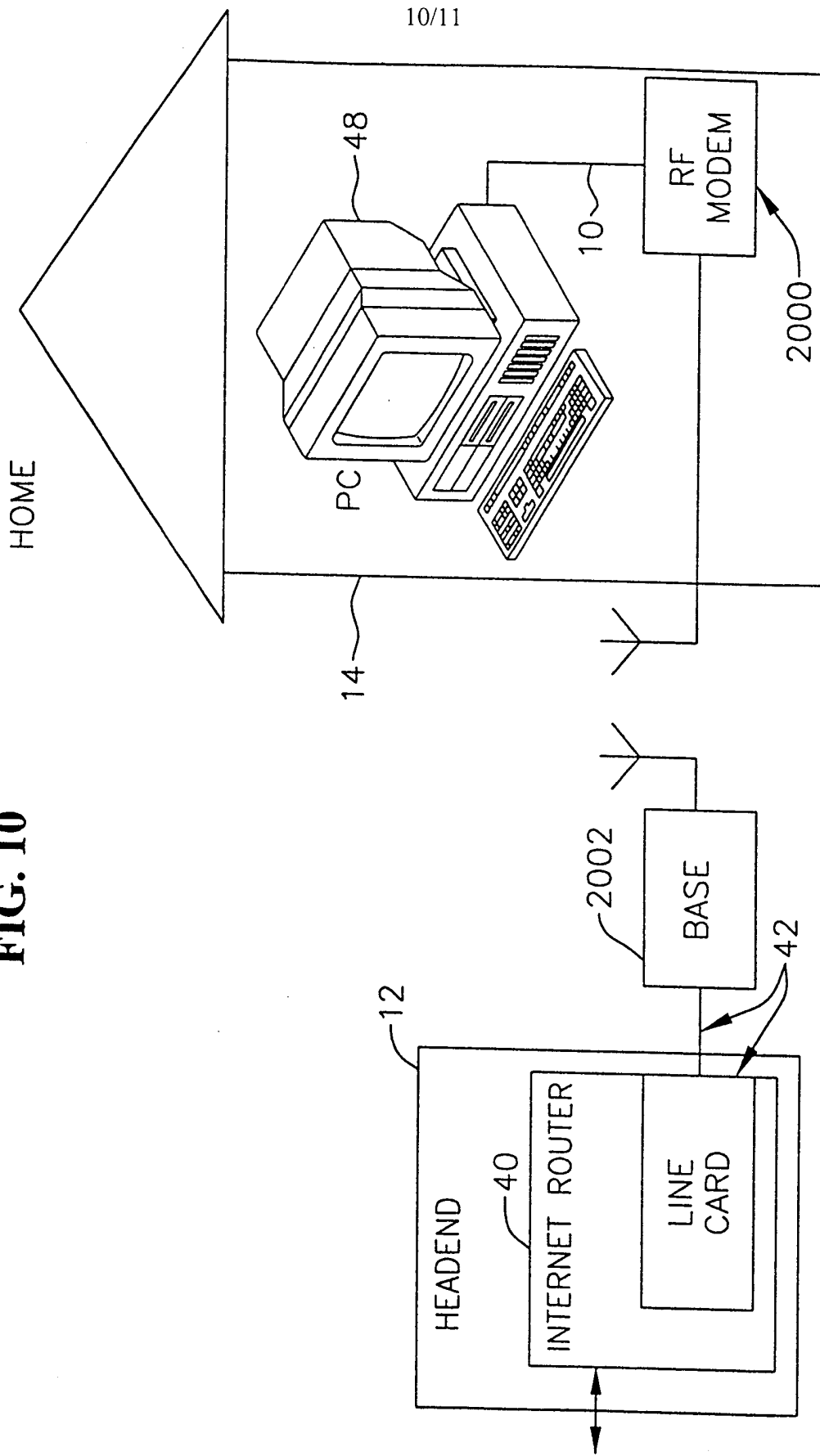

FIG. 11

