

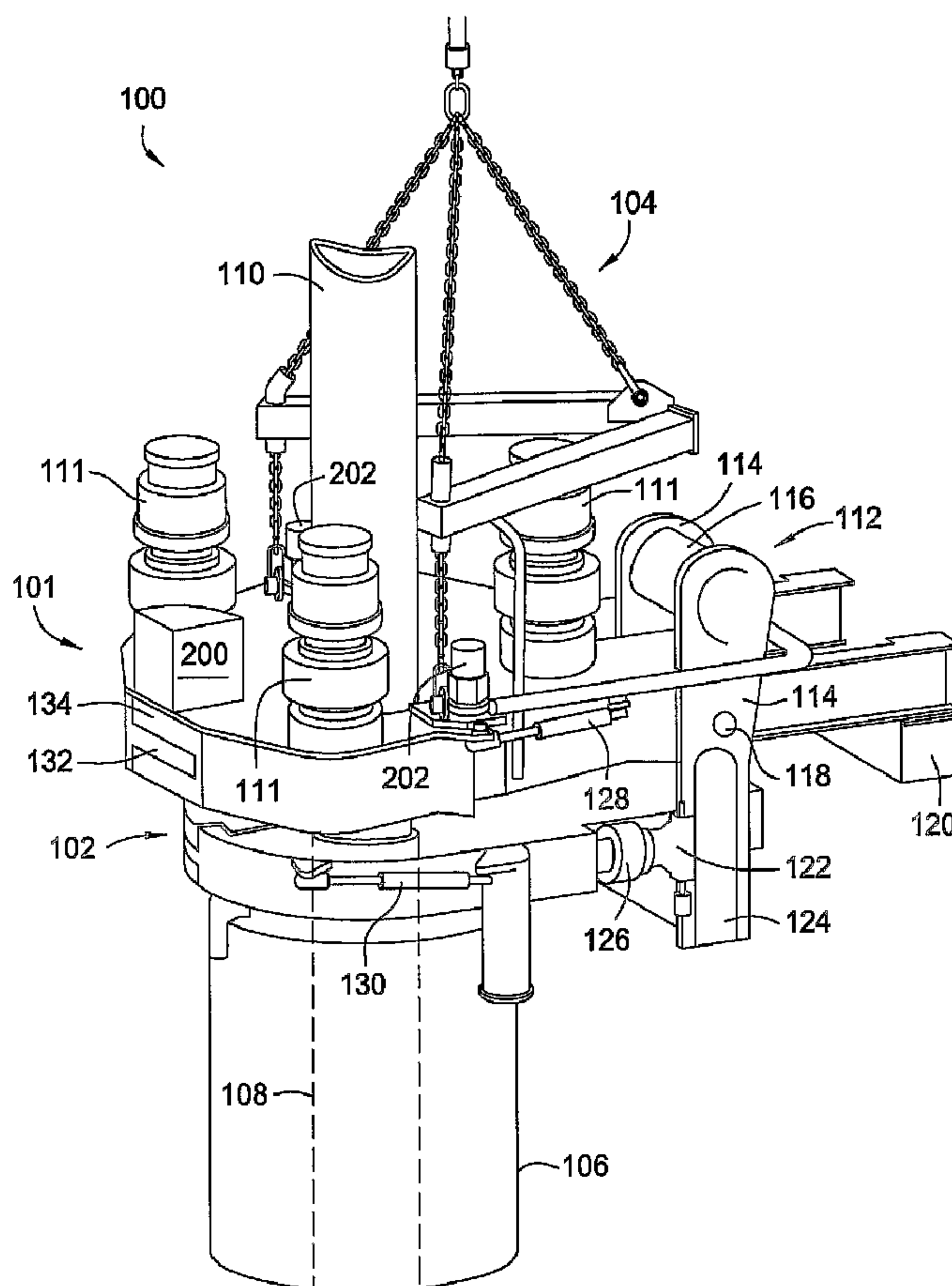

(86) Date de dépôt PCT/PCT Filing Date: 2004/03/05
 (87) Date publication PCT/PCT Publication Date: 2004/09/16
 (45) Date de délivrance/Issue Date: 2009/07/21
 (85) Entrée phase nationale/National Entry: 2005/09/01
 (86) N° demande PCT/PCT Application No.: US 2004/006753
 (87) N° publication PCT/PCT Publication No.: 2004/079148
 (30) Priorité/Priority: 2003/03/05 (US60/452,270)

(51) Cl.Int./Int.Cl. *E21B 19/16* (2006.01)
 (72) Inventeur/Inventor:
 BECKINGHAUSEN, JOERG E. SCHULZE, DE
 (73) Propriétaire/Owner:
 WEATHERFORD/LAMB, INC., US
 (74) Agent: DEETH WILLIAMS WALL LLP

(54) Titre : PINCE
 (54) Title: TONG



(57) Abrégé/Abstract:

Methods and apparatus for making and breaking tubular connections within a tubular string are disclosed. In certain aspects, a tong assembly includes gated power and back up tongs (102) coupled to a torque bar (112). Jaws (306) of the tongs may be

(57) **Abrégé(suite)/Abstract(continued):**

arranged circumferentially with support members (308) disposed between adjacent jaws to substantially complete a 360° closed circle. A hydraulic circuit may equally distribute fluid and pressure to actuate the jaws. The power tong may include a gated rotor driven by at least three drive motors (111) . The rotor may be selectively physically locked from rotation or movement by one or more rotor locks. Further, the tong assembly may include an interlock that prevents activation of the drive motors until the rotor locks actuate to unlock the rotor. Additionally, gate locks may secure the tongs and rotor when closed, and a releasable coupling arrangement may aid engagement of a motor to a rotor pump.

(12) INTERNATIONAL APPLICATION PUBLISHED UNDER THE PATENT COOPERATION TREATY (PCT)

(19) World Intellectual Property
Organization
International Bureau



(43) International Publication Date
16 September 2004 (16.09.2004)

PCT

(10) International Publication Number
WO 2004/079148 A3

- (51) International Patent Classification⁷: **E21B 19/16**
- (21) International Application Number: PCT/US2004/006753
- (22) International Filing Date: 5 March 2004 (05.03.2004)
- (25) Filing Language: English
- (26) Publication Language: English
- (30) Priority Data:
60/452,270 5 March 2003 (05.03.2003) US
- (71) Applicant (for all designated States except US): **WEATHERFORD/LAMB, INC.** [US/US]; 515 Post Oak Boulevard, Suite 600, Houston, TX 77027 (US).
- (72) Inventor; and
(75) Inventor/Applicant (for US only): **BECKINGHAUSEN, Joerg, E., Schulze** [US/DE]; Im Imbbleek, 30827 Garbsen (DE).
- (74) Agent: **PATTERSON, William, B.**; Moser, Patterson & Sheridan, L.L.P., 3040 Post Oak Boulevard, Suite 1500, Houston, TX 77056 (US).
- (81) Designated States (unless otherwise indicated, for every kind of national protection available): AE, AG, AL, AM, AT, AU, AZ, BA, BB, BG, BR, BW, BY, BZ, CA, CH, CN, CO, CR, CU, CZ, DE, DK, DM, DZ, EC, EE, EG, ES, FI, GB, GD, GE, GH, GM, HR, HU, ID, IL, IN, IS, JP, KE, KG, KP, KR, KZ, LC, LK, LR, LS, LT, LU, LV, MA, MD, MG, MK, MN, MW, MX, MZ, NA, NI, NO, NZ, OM, PG, PH, PL, PT, RO, RU, SC, SD, SE, SG, SK, SL, SY, TJ, TM, TN, TR, TT, TZ, UA, UG, US, UZ, VC, VN, YU, ZA, ZM, ZW.
- (84) Designated States (unless otherwise indicated, for every kind of regional protection available): ARIPO (BW, GH, GM, KE, LS, MW, MZ, SD, SL, SZ, TZ, UG, ZM, ZW), Eurasian (AM, AZ, BY, KG, KZ, MD, RU, TJ, TM), European (AT, BE, BG, CH, CY, CZ, DE, DK, EE, ES, FI, FR,

[Continued on next page]

(54) Title: TONG

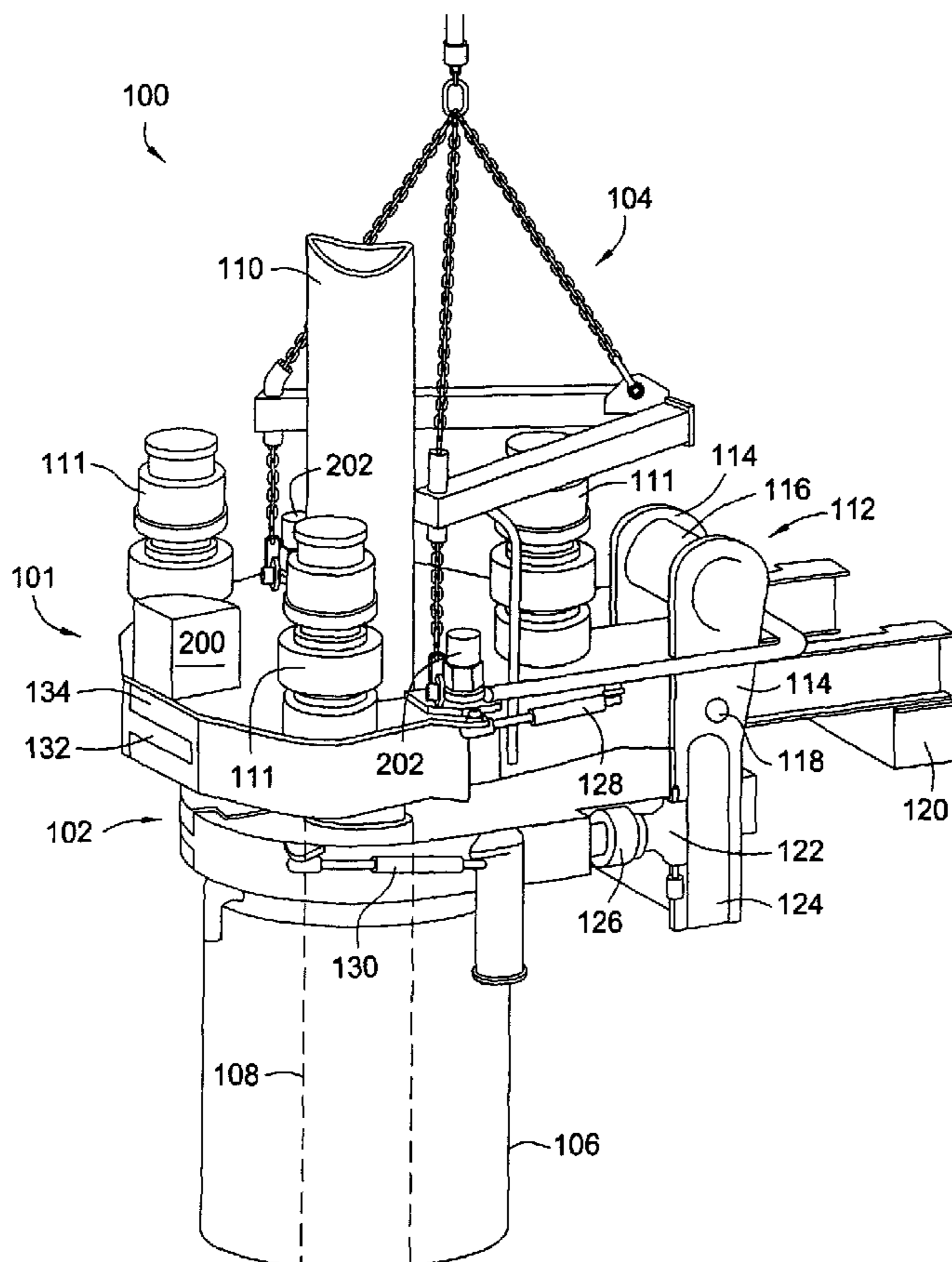

(57) Abstract: Methods and apparatus for making and breaking tubular connections within a tubular string are disclosed. In certain aspects, a tong assembly includes gated power and back up tongs (102) coupled to a torque bar (112). Jaws (306) of the tongs may be arranged circumferentially with support members (308) disposed between adjacent jaws to substantially complete a 360° closed circle. A hydraulic circuit may equally distribute fluid and pressure to actuate the jaws. The power tong may include a gated rotor driven by at least three drive motors (111). The rotor may be selectively physically locked from rotation or movement by one or more rotor locks. Further, the tong assembly may include an interlock that prevents activation of the drive motors until the rotor locks actuate to unlock the rotor. Additionally, gate locks may secure the tongs and rotor when closed, and a releasable coupling arrangement may aid engagement of a motor to a rotor pump.

WO 2004/079148 A3

WO 2004/079148 A3



GB, GR, HU, IE, IT, LU, MC, NL, PL, PT, RO, SE, SI, SK, TR), OAPI (BF, BJ, CF, CG, CI, CM, GA, GN, GQ, GW, ML, MR, NE, SN, TD, TG).

(88) Date of publication of the international search report:
11 November 2004

Published:

- *with international search report*
- *before the expiration of the time limit for amending the claims and to be republished in the event of receipt of amendments*

For two-letter codes and other abbreviations, refer to the "Guidance Notes on Codes and Abbreviations" appearing at the beginning of each regular issue of the PCT Gazette.

TONG**CROSS-REFERENCE TO RELATED APPLICATIONS**

[0001] This application claims benefit of United States provisional patent application serial number 60/452,270, filed March 5, 2003. This application is a continuation-in-part
5 of co-pending U.S. Patent Application Serial No. 10/048,353, filed July 14, 2000, which is herein incorporated by reference. This application is a continuation-in-part of co-pending U.S. Patent Application Serial No. 10/146,599, filed May 15, 2002, which is a continuation-in-part of U.S. Patent Application Serial No. 10/074,947, filed February 12, 2002, all of which are herein incorporated by reference.

10 BACKGROUND OF THE INVENTION**Field of the Invention**

[0002] The invention generally relates to methods and apparatus for use in making or breaking tubular connections. More particularly, the invention relates to a tong assembly for use in making or breaking tubular connections within a tubular string of an
15 oil or gas well.

Description of the Related Art

[0003] Construction of oil or gas wells usually requires making long tubular strings that make up casing, risers, drill pipe or other tubing. Due to the length of these strings, sections or stands of tubulars are progressively added to the tubular string as it is
20 lowered from a drilling platform. In particular, applying slips of a spider located in the floor of the drilling platform usually restrains the tubular string from falling when it is desired to add a section or stand of tubular. The new section or stand of tubular is then moved from a rack to above the spider. The threaded pin of the section or stand of tubular to be connected is then located over the threaded box of the tubular string and
25 a connection is made up by rotation therebetween. Thereafter, the spider releases the newly extended tubular string, and the whole tubular string lowers until the top of the tubular string is adjacent the spider whereupon the slips of the spider reapply to maintain the position of the tubular string for repeating the process.

[0004] It is common practice to use a tong assembly to apply a predetermined torque to the connection in order to make this connection. The tong assembly is typically located on the platform, either on rails, or hung from a derrick on a chain. In order to make up or break out a threaded connection, the tong assembly includes a two
5 tong arrangement. An active (or power) tong supplies torque to the section of tubular above the threaded connection, while a passive (or back up) tong supplies a reaction torque to a lower tubular below the threaded connection. Particularly, the back up tong clamps the lower tubular below the threaded connection and prevents it from rotating. The clamping of the tubulars may be performed mechanically, hydraulically, or
10 pneumatically. The power tong clamps the upper part of the connection and is driven so that it supplies torque for at least a limited angle.

[0005] In order to make up or break out a connection between tubulars in a tubular string, torque must be supplied over a large angle without having to take time to release and clamp the tubular again. Large diameter and heavy tubulars such as risers have
15 threaded connections requiring a high torque that prior tong assemblies fail to provide. For example, the prior tong assemblies having one or two drives fail to provide a sufficient rotation force to a rotary of the power tong. Further, a jaw assembly of the prior tong assemblies tends to tilt and provide a non-uniform load on the tubular surfaces when used at the high torques. When the jaw assembly tilts, only a portion of
20 the jaw assembly contacts the tubular, thereby causing damage to the tubular, limiting the torque that can be applied and causing failure of the jaw assembly itself.

[0006] In use, the reaction force on the power tong transmits through the connection and the back up tong to the lower tubular. This torsional force creates a side force tending to move the back up tong and power tong out of axial alignment, thereby
25 bending the tubular string at the connection. Thus, torque transmitting devices used with power tongs and back up tongs inhibit them from moving out of axial alignment. However, prior torque transmitting devices limit how close that the power tong and back up tong may be spaced.

[0007] The possibility of a premature rotation of the rotary gear such as prior to
30 closing gates of the tong assembly presents a serious potential danger to an operator. While the gates are open, the rotary gear may become misaligned with the power tong.

Further, premature rotation can cause costly and time consuming damage to the tong assembly.

[0008] Therefore, there exists a need for an improved method and apparatus for making or breaking a tubular connection. There exists a further need for a tong
5 assembly that includes an improved jaw assembly, rotor, torque transmitting device, and/or safety features.

SUMMARY OF THE INVENTION

[0009] The invention generally relates to methods and apparatus for making and breaking tubular connections within a tubular string. In certain aspects, a tong
10 assembly includes gated power and back up tongs coupled to a torque bar. Jaws of the tongs may be arranged circumferentially with support members disposed between adjacent jaws to substantially complete a 360° closed circle. A hydraulic circuit may equally distribute fluid and pressure to actuate the jaws. The power tong may include a gated rotor driven by at least three drive motors. The rotor may be selectively
15 physically locked from rotation or movement by one or more rotor locks. Further, the tong assembly may include an interlock that prevents activation of the drive motors until the rotor locks actuate to unlock the rotor. Additionally, gate locks may secure the tongs and rotor when closed, and a releasable coupling arrangement may aid engagement of a motor to a rotor pump.

BRIEF DESCRIPTION OF THE DRAWINGS

[0010] So that the manner in which the above recited features of the present invention can be understood in detail, a more particular description of the invention, briefly summarized above, may be had by reference to embodiments, some of which are illustrated in the appended drawings. It is to be noted, however, that the appended
25 drawings illustrate only typical embodiments of this invention and are therefore not to be considered limiting of its scope, for the invention may admit to other equally effective embodiments.

[0011] Figure 1 is a view of an embodiment of a tong assembly in operation with a tubular string positioned therein.

[0012] Figure 2 is a side view of the tong assembly showing a detail of gate locks on a power tong and a back up tong and a detail of a rotor lock on the power tong.

[0013] Figure 3 is a section view of the power tong illustrating a rotor with jaws according to aspects of the invention.

5 [0014] Figure 4 is a top view of the power tong.

[0015] Figure 5 is a side view of a motor disposed on a housing of the power tong that operates a pump on the rotor in order to actuate the jaws.

[0016] Figure 5A is a view of an end of the motor along line 5A-5A in Figure 5.

[0017] Figure 5B is a view of an end of the pump along line 5B-5B in Figure 5.

10 [0018] Figure 6 is a schematic of a back up tong hydraulic circuit used to actuate jaws of the back up tong.

[0019] Figure 7 is a schematic illustrating engagement of the motor and the pump used in a rotor hydraulic circuit that actuates the jaws of the power tong.

15 [0020] Figure 8 is a schematic of a portion of a tong assembly hydraulic circuit that provides a safety interlock between the rotor lock and fluid supplied to operate drive motors.

DETAILED DESCRIPTION OF THE PREFERRED EMBODIMENT

20 [0021] The invention generally relates to a tong assembly for making up and breaking out a tubular connection such as between two tubulars in a tubular string. The tubular string may be made of tubulars that form a riser, casing, drill pipe or other tubing. In operation, the tong assembly grips the tubulars and applies torque to the connection. For example, the tong assembly may apply 300,000 foot pounds of torque to a riser thread connection in a riser string that is about twenty inches in diameter.

25 [0022] Figure 1 illustrates an embodiment of a tong assembly 100 according to aspects of the invention. The tong assembly 100 includes a power tong 101 disposed above a back up tong 102. In operation, the tong assembly 100 suspends from a

handling tool 104 that positions the tong assembly 100 around a tubular of a tubular string such as a lower tubular 108 held by a spider 106 and a stand or upper tubular 110. As described in more detail below, the power tong 101 grips the upper tubular 110, the back up tong 102 grips the lower tubular 108, and the power tong 101 rotates the upper tubular 110 in order to make up or break out a connection between the tubulars 108, 110. Three drive motors 111 operate to rotate the upper tubular 110.

[0023] Each of the tongs 101, 102 are segmented into three segments such that the front two segments pivotally attach to the back segment and enable movement of the tongs 101, 102 between an open and a closed position. In the open position, the front sections pivot outward enabling the tubulars 108, 110 to pass between the front sections so that the handling tool 104 can align the tubulars 108, 110 within the tongs 101, 102. The tongs 101, 102 move to the closed position as shown in Figure 1 prior to make up or break out operations. Pistons 128 (only one piston is visible) on each side of the power tong 101 operate to pivot the front segments relative to the back segment in order to open and close a gate between the front segments that is formed where an extension 132 on one of the front segments mates with a corresponding grooved portion 134 of the other front section. Similarly, pistons 130 (again only one piston is visible) on each side of the back up tong 102 operate to pivot the front segments relative to the back segment in order to move the back up tong between the open and closed position. The pistons 128, 130 may be operated by a tong assembly hydraulic circuit that supplies fluid pressure to various components of the tong assembly 100 through a common pressure source. As with all other components of the tong assembly 100 operated by the tong assembly hydraulic circuit, automated or manually operated valves (not shown) may be used to separately or in combination open and close fluid supply to each component (e.g. the pistons 128, 130) at the desired time.

[0024] A torque bar assembly 112 located adjacent a counterweight 120 connects the power tong 101 to the back up tong 102. The torque bar assembly 112 includes two arms 114 extending downward from each end of a horizontal top bar or suspension 116. A back end of the power tong 101 connects to a horizontal shaft 118 that extends between the arms 114 below the suspension 116. The shaft 118 may fit within bearings (not shown) in the arms 114 to permit pivoting of the power tong 101 relative to the torque bar assembly 112. Damping cylinders 400 (shown in Figure 4) connect

between a top of the power tong 101 and the suspension 116 to prevent free swinging of the power tong 101 about the shaft 118. Clamps 122 on the back up tong 102 grip a longitudinal recess 124 in the arms 114, thereby securing the back up tong 102 to the torque bar assembly 112. The clamps 122 slide along the recess 124 to permit
5 movement of the back up tong 102 relative to the power tong 101 during make up or break out operations. The torque bar assembly 112 provides a connection between the tongs 101, 102 that permits the back up tong 102 to rise into near contact with the power tong 101.

[0025] The torque bar assembly 112 keeps side forces out of the connection
10 between the tubulars 108, 110 by eliminating or at least substantially eliminating shear and bending forces. As the power tong 101 applies torque to the upper tubular 110, reaction forces transfer to the torque bar assembly 112 in the form of a pair of opposing forces transmitted to each arm 114. The forces on the arms 114 place the suspension 116 in torsion while keeping side forces out of the connection. A load cell and
15 compression link 126 may be positioned between the clamp 122 and back up tong 102 in order to measure the torque between the power tong 101 and back up tong 102 during make up and break out operations.

[0026] Figure 2 shows a side of the tong assembly 100 and a detail of a power tong gate lock 200, a back up gate lock 201 and a rotor lock 202. The gate locks 200, 201
20 lock the tongs 101, 102 in the closed position. The rotor lock 202 prevents rotation of a rotor 300 when in the open position and prevents any possible misalignment of parts of the rotor 300 caused by moving the power tong 101 to the open position since the rotor may be forced outward in the open position. Thus, the rotor lock 202 maintains the rotor 300 in position and prevents rotation of the rotor 300 until the rotor lock 202 is
25 actuated.

[0027] The power tong gate lock 200 includes an outer shroud 204 mounted on a housing 207 of the power tong 101. The outer shroud 204 supports a gear profiled bolt 206 having a lifting member 208 connected thereto. Rotation of a gear 216 mated with the gear profiled bolt 206 lowers and raises the gear profiled bolt 206 between a power
30 tong gate locked position and a power tong gate unlocked position. In the power tong gate locked position shown in Figure 2, the gear profiled bolt 206 inserts downward into

an aperture within the extension 132 and an aperture in the corresponding grooved portion 134 that form the gate in the housing 207 of the power tong 101. Thus, the gear profiled bolt 206 maintains the power tong 101 in the closed position by preventing movement between the extension 132 and the corresponding grooved portion 134 when in the power tong gate locked position. The gear may be actuated by a hydraulic or electric motor (not shown) controlled by the tong assembly hydraulic circuit.

[0028] At the end of the lifting member 208, a slotted lip 210 receives a recessed profile 212 at the top of a rotor bolt 214. Due to the slotted lip 210 fitting in the recessed profile 212, the lifting member 208 which raises and lowers with the gear profiled bolt 206 acts to raise and lower the rotor bolt 214 when the rotor bolt 214 is aligned below the lifting member 208. Similar to the housing of the power tong 101, a rotor 300 is gated so that the rotor 300 opens and closes as the power tong 101 moves between the open and closed positions. Thus, the rotor 300 includes a rotor extension 232 and a corresponding rotor grooved portion 234 that each have an aperture therein for receiving the rotor bolt 214 which prevents movement between the rotor extension 232 and the corresponding rotor grooved portion 234 while in the power tong gate locked position. As the rotor 300 rotates during make up and break out operations, the recessed profile 212 of the rotor bolt 214 slides out of engagement with the slotted lip 210 and may pass through the slotted lip 210 with each revolution of the rotor 300. The rotor bolt 214 realigns with the lifting member 208 when the rotor returns to a start position such that the rotor bolt 214 may be raised to the power tong gate unlocked position. Only when the rotor 300 is in the start position with segments of the rotor 300 properly aligned may the power tong 101 be moved to the open position. Figure 3 further illustrates the power tong 101 in the start position with the rotor bolt 214 and the gear profiled bolt 206 maintaining the power tong 101 in the closed position.

[0029] The back up gate lock 201 locks the gate on the back up tong 102 in the closed position similar to the power tong gate lock 200 for the power tong 101. A single back up bolt 218 operated by a gear 220 moves between a back up gate locked position and a back up gate unlocked position. Since the back up tong 102 does not have a front housing or a rotor that rotates, a back up jaw assembly may include a gated section therein with mating features such as the gate of the power tong 101. Thus, the bolt 218 in the back up gate locked position prevents movement between

members in the gated section of the back up jaw assembly similar to the gear profiled bolt 206 and rotor bolt 214 used in the power tong gate lock 200 on the power tong 101.

[0030] Referring still to Figure 2, the rotor lock 202 mounts to the housing 207 of the power tong 101 and includes a body 222, a female end 224, a piston 225 and a spring 228. The rotor lock 202 moves between a rotor locked position and a rotor unlocked position. The rotor lock 202 normally biases to the rotor locked position and must be actuated by fluid pressure from the tong assembly hydraulic circuit to the rotor unlocked position. In the rotor locked position shown, the female end 224 coupled to the piston 225 receives a male member 226 protruding from the rotor 300. The male member 226 aligns below the female end 224 when the rotor 300 is in the start position. The engagement between the female end 224 and the male member 226 prevents rotation and movement of the portion of the rotor having the male member 226 thereon. As shown in the top view of the power tong 101 in Figure 4, the power tong 101 may include two rotor locks 202 on each side which may be aligned with pivot points 304 (shown in Figure 3) where the front segments of both the housing 207 and rotor 300 open. Thus, the rotor locks 202 may engage both front opening segments of the rotor 300 to secure the segments relative to the housing 207 of the power tong 101 when the power tong 101 is in the open position. Prior to make up or break out operations, the female end 224 retracts to the rotor unlocked position by fluid pressure applied to the piston 225 in order to urge the piston 225 upward against the bias of the spring 228. Thus, the rotor lock 202 permits rotation of the rotor 300 only when in the rotor unlocked position since the female end 224 and male member 226 disengage.

[0031] Figure 3 illustrates the rotor 300 within the power tong 101. The rotor 300 includes a segmented rotary gear 302, three active jaws 306, and support members 308 disposed between the jaws 306. The support members 308 are fixed within the inner diameter of the rotary gear 302 such that the jaws 306 and the support members 308 rotate with the rotary gear 302. Prior to rotating the rotor 300, the jaws 306 move inward in a radial direction from a release position shown to a gripping position with the jaws 306 in gripping contact with the tubular 110. A spring (not shown) biases the jaws 306 to the release position. Each of the jaws 306 include two pistons 312 hydraulically operated by a separate rotor hydraulic circuit to push a jaw pad 314 against the tubular

110 in the gripping position. Three pinions 310 driven by the three motors 111 (shown in Figure 1) mesh with an outer circumference of the rotary gear 302 in order to rotate the rotor 300 during make up and break out operations. Since the pivot points 304 for both the housing 207 and rotor 300 are the same, there is no relative movement
5 between the rotor 300 and housing 207 as the power tong 101 moves between the open and closed positions. Consequently, the two motors 111 on the front segments of the housing 207 do not move relative to the rotary gear 302 such that it is not necessary to actuate the two motors 111 as the power tong 101 opens and closes.

[0032] The rotary gear 302 may be tensioned prior to assembly such that the rotary
10 gear 302 is initially deformed. Thus, when the rotary gear 302 is assembled in the power tong 101 and when the tubular 110 is gripped by the jaws 306, the deformed rotary gear reworks to obtain a circular outer circumference.

[0033] Support rollers 316 hold the rotary gear 302 in order to axially position the
15 rotor 300 within the power tong 101. Each of the pinions 310 creates a force on the rotary gear 302 that is perpendicular to the tangential. Due to the 120° spacing of the pinions 310, these forces are all directed to the center of the rotor 300 and cancel one another, thereby centrally aligning the rotor 300. Therefore, the rotor 300 does not require radial guiding since the rotary gear 302 centrally aligns itself when a load is placed on the pinions 310 arranged at 120° around the rotary gear 302.

[0034] The jaws 306 and support members 308 laterally support one another
20 throughout a 360° closed circle such that corresponding torque from the rotor 300 only transmits to the tubular 110 in a tangential direction without resulting in any tilting of the jaws 306. During make up and break out operations, a side face of one jaw 306 having a close contact with a side face of an adjacent support member 308 transmits force to
25 the adjacent support member 308 which is in close contact with another jaw 306. The closed 360° arrangement effectively locks the jaws 306 and support members 308 in place and helps the jaws 306 and support members 308 to laterally support one another, thereby inhibiting tilting of the jaws 306. Thus, load on the tubular 110 equally distributes at contact points on either side of the jaw pads 314. Adapters (not shown)
30 for both the support members 308 and jaws 306 may be added in order to allow the power tong 101 the ability to grip tubulars having different diameters.

[0035] The jaw assembly (not shown) in the back up tong 102 may be identical to the rotor 300. However, the jaw assembly in the back up tong 102 does not rotate such that an outer ring surrounding jaws in the back up tong may not be geared with motors providing rotation.

5 [0036] The top view of the power tong 101 in Figure 4 shows a motor 402 used to operate a pump 404 that supplies hydraulic pressure to the rotor hydraulic circuit that actuates the jaws 306. The motor 402 may be actuated by the tong assembly hydraulic circuit. The motor 402 mounts on the housing 207 while the pump mounts on the rotor 300. Therefore, the motor 402 must disengage from the pump 404 after the pump 404
10 actuates the jaws 306 in order to allow the pump 404 to rotate with the rotor 300 during make up and break out operations.

[0037] Figures 5, 5A and 5B illustrate a releasable coupling arrangement between the motor 402 secured to the housing 207 and the pump 404 secured to the rotor 300. The motor 402 slides along a guide shaft 500 between an engaged position toward the
15 pump 404 and a disengaged position away from the pump 404. As shown, a spring 502 biases the motor 402 to the disengaged position. Hydraulic fluid supplied from the tong assembly hydraulic circuit moves the motor 402 against the bias of the spring 502 toward the pump 404. As the motor 402 moves toward the pump 404, a coupling such as a claw 504 of the motor 402 engages a mating coupling such as an elongated S-
20 shaped bar 506 of the pump 404. The claw 504 and the S-shaped bar 506 provide a wide angle for possible engagement with each other. However, the claw 504 and S-shaped bar 506 may interferingly hit one another without engaging. To simplify the next engagement of the claw 504 with the S-shaped bar 506 due to a missed engagement or for subsequent operations of the pump 404, the motor 402 rotates the
25 claw 504 a small amount as the motor 402 slides on the guide shaft 500 back to the disengaged position. As shown in further detail in Figure 7, pressurized fluid used to fill a piston chamber in order to move the motor 402 on the guide shaft 500 toward the pump 404 flows to the motor 402 to turn the claw 504. Since the volume of the piston chamber remains the same, the claw 504 of the motor 402 rotates a fixed amount with
30 every movement of the motor 402 between the engaged and disengaged positions.

[0038] Figure 6 illustrates a schematic of a back up tong hydraulic circuit 600 used to actuate jaws 602 of the back up tong 102 in order to grip the lower tubular 108 as shown in Figure 1. A grip line 601 from the tong assembly hydraulic circuit selectively supplies fluid pressure to a back up tong motor 603 that operates a single back up tong pump 604. The jaws 602 of the back up tong 102 connect to the back up tong pump 604 which supplies an equal volume and pressure of fluid to each of the jaws 602 through three equal flow outlets 606. To prevent a stop of the motor/pump 603, 604 with only one of the jaws 602 in gripping contact, the hydraulic circuit 600 provides a cascade circuit with flow from all three jaws 602 passing to a single common adjustable pressure limiter 608, a single common preset safety valve 610 and a single common release check valve 612. Due to the arrangement of the two check valves 614, the pump 604 continues to supply pressurized fluid even if one of the jaws 602 grips prior to the other jaws 602. Pressurized fluid supplied to the jaw gripping prematurely flows to the tank 616 while the other jaws continue to receive fluid pressure for proper actuation. Therefore, there is no volumetric influence of one of the jaws 602 with respect to the other jaws. After completing the make up or break out operation, a hydraulic signal through a release line 618 of the tong assembly hydraulic circuit opens the release check valve 612 and permits fluid pressure acting on the jaws 602 to dump to the tank 616. The back up tong hydraulic circuit 600 with the pump 604 may supply high pressures such as greater than 6000 pounds per square inch or 500 bar.

[0039] Figure 7 shows a schematic illustrating engagement of the motor 402 and the pump 404 used in a rotor hydraulic circuit 700 that actuates the jaws 306 of the power tong 101. The jaws 306 actuate through a similar manner as described above with respect to the back up tong hydraulic circuit 600 in Figure 6. However, a release valve 702 is opened upon completing the make up or break out operation. The schematic in Figure 7 also illustrates the motor 402 that is moveable between the engaged and disengaged positions. To move the motor 402 from the disengaged position to the engaged position, fluid selectively supplied from the tong assembly hydraulic circuit to an engage pump line 704 passes through check valve 708 and enters piston chamber 710 in order to move the motor 402 toward the pump 404. The fluid pressure in the engage pump line 704 closes check valve 706. However, release of fluid pressure from the engage pump line 704 permits pressurized fluid from the piston chamber 710 to

pass through check valve 706 into a motor drive line 712 in order to rotate a claw 504 of the motor 402 as described above when the motor returns from the engaged position to the disengaged position.

[0040] Figure 8 illustrates an interlock portion 800 of the tong assembly hydraulic circuit that provides a safety interlock that includes the rotor locks 202 and a motor
5 lockout that selectively blocks fluid supplied to operate the drive motors 111. The interlock portion 800 includes a normally open pilot valve 802 having an input from a dump line 803 and an output to a tank 816, a first check valve 804 having an input from a break out supply line 805 and an output to a reverse drive line 810, and a second
10 check valve 806 having an input from a make up supply line 807 and an output to a forward drive line 812. An automated or manually operated drive valve 818 selectively supplies fluid pressure to one of the supply lines 805, 807 at the appropriate time. Fluid supplied through the reverse drive line 810 operates the motors 111 for break out, and fluid supplied through the forward drive line 812 operates the motors 111 in an opposite
15 direction for make up. Thus, the drive motors 111 only operate when the check valves 804, 806 can open to permit fluid flow between one of the supply lines 805, 807 and a corresponding one of the drive lines 810, 812. A first pilot port line 809 connects a pilot port of the first check valve 804 with the break out line 805, and a second pilot port line 811 connects a pilot port of the second check valve 804 with the make up line 807.
20 The check valves 804, 806 only open when the pilot port lines 809, 811 supply fluid pressure to the pilot ports. However, the pilot port lines 809, 811 do not supply an opening pressure to the pilot ports of the check valves 804, 806 when the pilot valve 802 is open since the pilot port lines 809, 811 connect through check valve 813 to the dump line 803 that passes fluid to the tank 816 when the pilot valve 802 is open.

25 [0041] As described above, the rotor locks 202 physically block rotation of the rotor 300 until a fluid pressure is applied to the rotor locks 202 in order to place the rotor locks 202 in the rotor unlocked position. Thus, the fluid pressure for placing the rotor locks 202 in the rotor unlocked position is supplied from the tong assembly hydraulic circuit through a disengage locks line 808 that may be controlled independently from
30 the supply lines 805, 807 by a lock valve 820. A portion of the fluid from the disengage locks line 808 is supplied to a pilot port of the pilot valve 802 in order to close the pilot valve 802 only when both the rotor locks 202 are in the rotor unlocked position. Once

the pilot valve 802 closes, fluid pressure from either of the supply lines 805, 807 can pressurize a corresponding one of the pilot port lines 809, 811 that are no longer open to the tank 816, thereby permitting opening of a corresponding one of the check valves 804, 806. Thus, opening the drive valve 818 supplies fluid selectively to one of the
5 supply lines 805, 807, which are blocked from operating the drive motors 111 until actuation of the rotor locks 202 unlocks the interlock that provides the motor lockout. Once both the rotor locks 202 actuate and the drive valve 818 is opened to permit fluid flow to the appropriate supply line 805, 807, a pressurized fluid is simultaneously supplied to all of the motors 111 through a corresponding one of the drive lines 810,
10 812 during make up or break out. Further, each motor 111 produces the same torque and any mechanical parts for "locking" such torque are not necessary as all the motors 111 simultaneously stop hydraulically due to the check valves 804, 806. A gear change 814 may be used to adjust the suction volume of the motors 111 in order to adjust the speed of the motors 111. Additionally, a solenoid valve (not shown) can be activated
15 such that the drive motors 111 are also immediately stopped, and a pressure limiter 822 may protect the interlock portion 800.

[0042] In alternative embodiments, the pilot valve 802 is closed by a signal other than the hydraulic signal from the disengage locks line 808. For example, the pilot valve 802 may be controlled to close by an electric signal supplied thereto or may be
20 manually closed. Further, the hydraulic circuit shown for the interlock portion 800 may be used in applications and methods other than tong assembly 100 where there is a desire to block actuation of motors prior to receiving a signal from an interlock.

[0043] The tong assembly 100 described herein may be used in a method of making up a tubular connection between a first tubular 110 and a second tubular 108. For
25 clarity, the method is described using the reference characters of the figures described herein when possible. The method includes opening a power tong 101 and back up tong 102 of the tong assembly 100 and positioning the tubulars 108, 110 therein. The method further includes, closing the tongs 101, 102 around the tubulars 108, 110, locking gate locks 200, 201 to maintain the tongs 101, 102 and a rotor 300 in the closed
30 position, actuating jaws 306 of the tongs 101, 102 such that the power tong 101 grips the first tubular 110 and the back up tong 102 grips the second tubular 108, unlocking a rotor lock 202 to permit rotation of the rotor 300, and unlocking an interlock including a

rotor motor lockout. Additional, the method includes rotating the rotor 300 by distributing a drive force on the rotor 300 such as by simultaneous rotation of at least three motors 111, wherein rotating the rotor 300 rotates the first tubular 110 relative to the second tubular 108 and forms the connection. The method may be used with
5 connections in tubulars having diameters greater than fifteen inches such as risers.

[0044] While the foregoing is directed to embodiments of the present invention, other and further embodiments of the invention may be devised without departing from the basic scope thereof, and the scope thereof is determined by the claims that follow.

CLAIMS

1. An apparatus for handling a first tubular and a second tubular during make up and break out operations, comprising:
 - a tong (101) having jaws (306) radially arranged within a rotatable member (300) and moveable toward a center for gripping the first tubular (110), wherein each jaw is actuated by a substantially equal supply of fluid independently controlled by a common pressure limiter; and
 - a back up member (102) for gripping the second tubular (108) and preventing rotation thereof.
2. The apparatus of claim 1, further comprising an interlock, the interlock selectively preventing operation of the rotatable member (300).
3. The apparatus of claim 1, further comprising a support member (308) rigidly disposed in between the jaws (306) to provide lateral support thereto when the jaws (306) grip the first tubular (110).
4. The apparatus of claim 3, further comprising the support member (308) is disposed in an alternating fashion between the jaws (306).
5. The apparatus of claim 1, further comprising at least three drive motors (111) arranged around the rotatable member (300) for simultaneously rotating the rotatable member (300) within the tong (101).
6. The apparatus of claim 1, further comprising a torque bar (112) assembly for at least reducing shear and bending forces, wherein the tong and back up member couple to arms of the torque bar assembly.
7. The apparatus of claim 1, wherein the first (110) and second tubulars (108) are part of a riser string.
8. The apparatus of claim 1, wherein the first (110) and second tubulars (108) are at least fifteen inches (0.381 meters) in diameter.

9. The apparatus of claim 1, further comprising a gate lock (200) for securing a gate in a housing of the tong (101) and a gate of the rotatable member (300) in a closed position.
10. The apparatus of claim 1, further comprising a releasable coupling arrangement having an actuation piston for moving a motor (402) into engagement with a pump (404) on the rotatable member (300), wherein a fluid return of the actuation piston is in fluid communication with the motor (402) for providing a limited motor operation.
11. The apparatus of claim 1, wherein the common pressure limiter is in fluid communication with all the jaws through a cascading circuit.
12. The apparatus of claim 11, wherein the cascading circuit is formed by check valves.
13. The apparatus of claim 6, wherein the torque bar is a member coupled between the arms, for absorbing torsion from the reaction force in each arm.
14. The apparatus of claim 13, further comprising a compression link attachable between the back up tong and the torque bar assembly.
15. A method of making up a tubular connection between a first tubular and a second tubular, comprising:
- providing a tong having a plurality of jaws radially arranged within a rotatable member;
 - supplying fluid at substantially the same pressure to each of the jaws to move the jaws toward a center to cause the jaws to grip the first tubular such that, in the event of one of the jaws gripping the first tubular before another of the jaws, the supply of pressurized fluid to said other jaw continues until said other jaws grips the first tubular; and
 - gripping the second tubular by a back up member to prevent rotation of the second tubular.
16. The method of claim 15, further comprising rotating a rotor in the tong by distributing a drive force on the rotor, wherein rotating the rotor rotates the first tubular and forms the connection.

17. The method of claim 16, further comprising unlocking an interlock that provides a motor lockout preventing operation of at least one motor for rotating the rotor.
18. The method of claim 16, further comprising unlocking the rotor, wherein unlocking the rotor sends a signal that enables rotating the rotor.
19. The method of claim 16, further comprising unlocking the rotor, wherein unlocking the rotor sends a hydraulic signal that permits opening of check valves that block flow of hydraulic fluid to at least one motor that drives the rotor.
20. The method of claim 16, wherein rotating the rotor includes operating three drive motors spaced about the rotor.
21. The method of claim 16, wherein the connection is a riser connection.
22. The method of claim 16, wherein rotating the rotor supplies at least 100,000 foot pounds of torque to the connection.
23. The method of claim 17, wherein the motor is selectively enabled by disconnecting fluid flow to the motor by a check valve, wherein the fluid flow operates the motor; and
sending a signal that opens the check valve to connect fluid flow to the motor at a desired time.
24. The method of claim 23, wherein sending the signal closes a pilot valve that fluidly connects a fluid supplied to a pilot port for opening the check valve to a drain.
25. The method of claim 23, wherein the signal includes an electric signal.
26. The method of claim 23, wherein the signal includes a hydraulic signal.
27. The method of claim 15, wherein the jaws are biased toward an ungripped position.
28. The method of claim 17, wherein gripping the tubular enables unlocking the interlock.

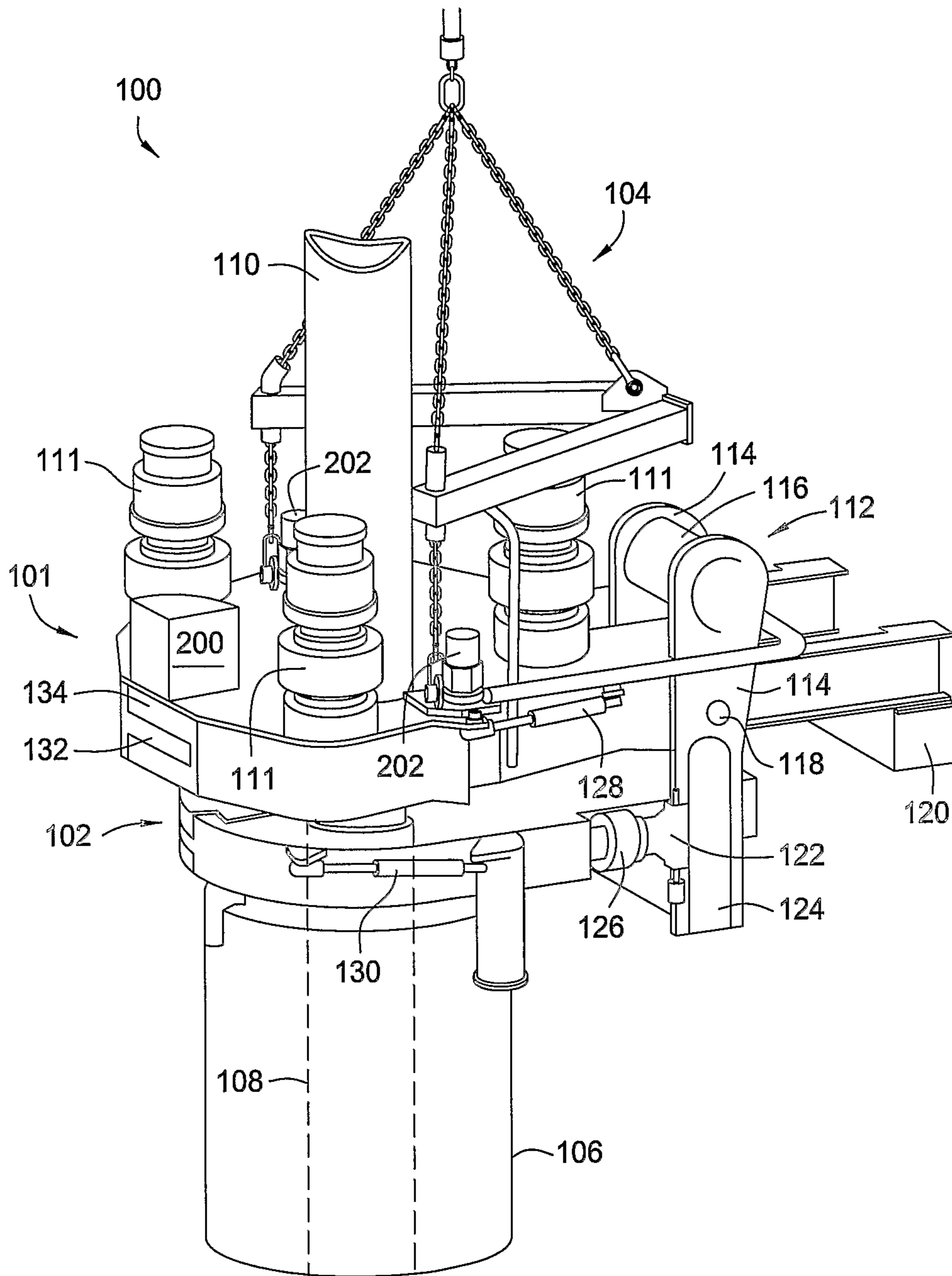
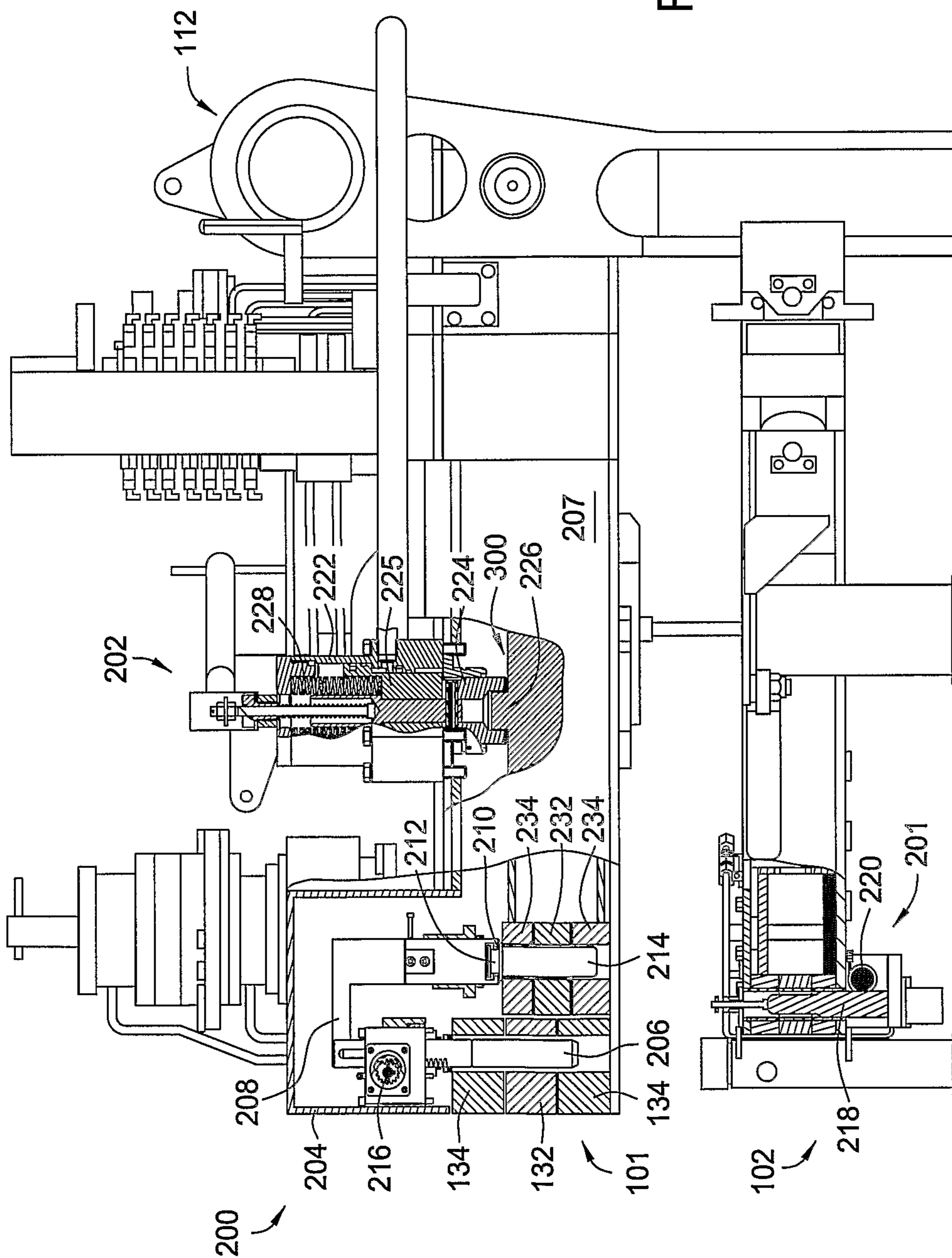

FIG. 1

FIG. 2



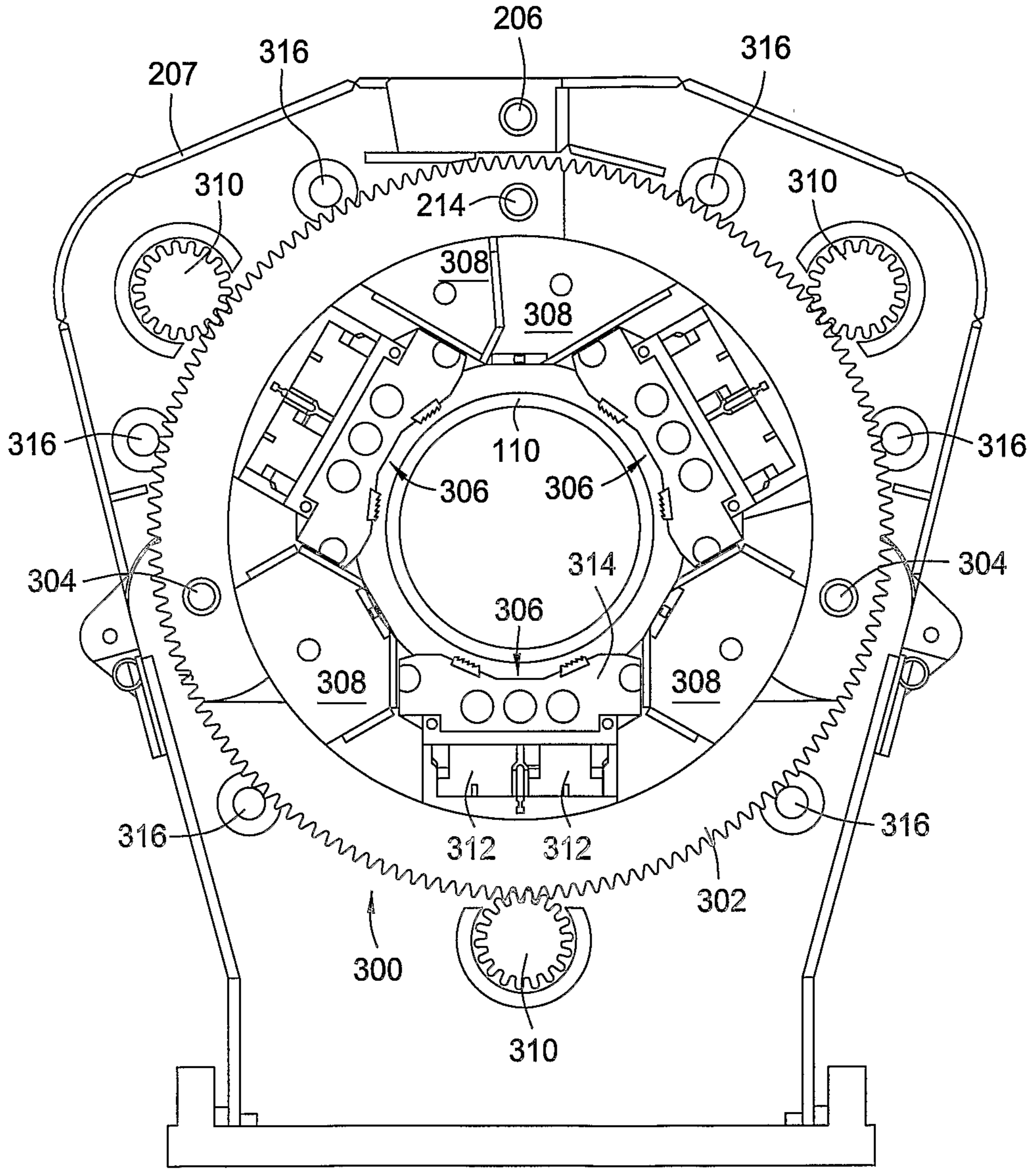

FIG. 3



4/9

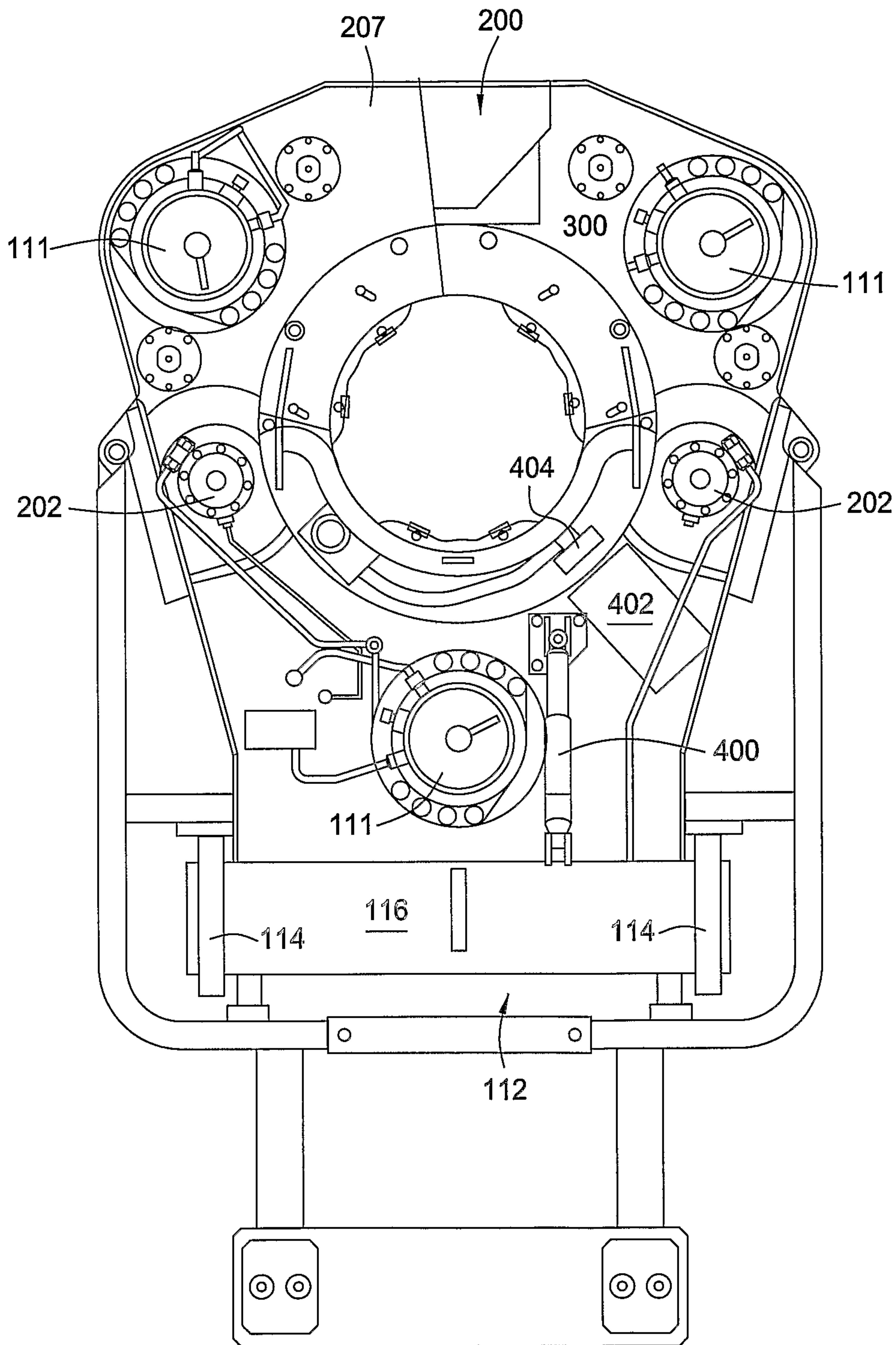

FIG. 4



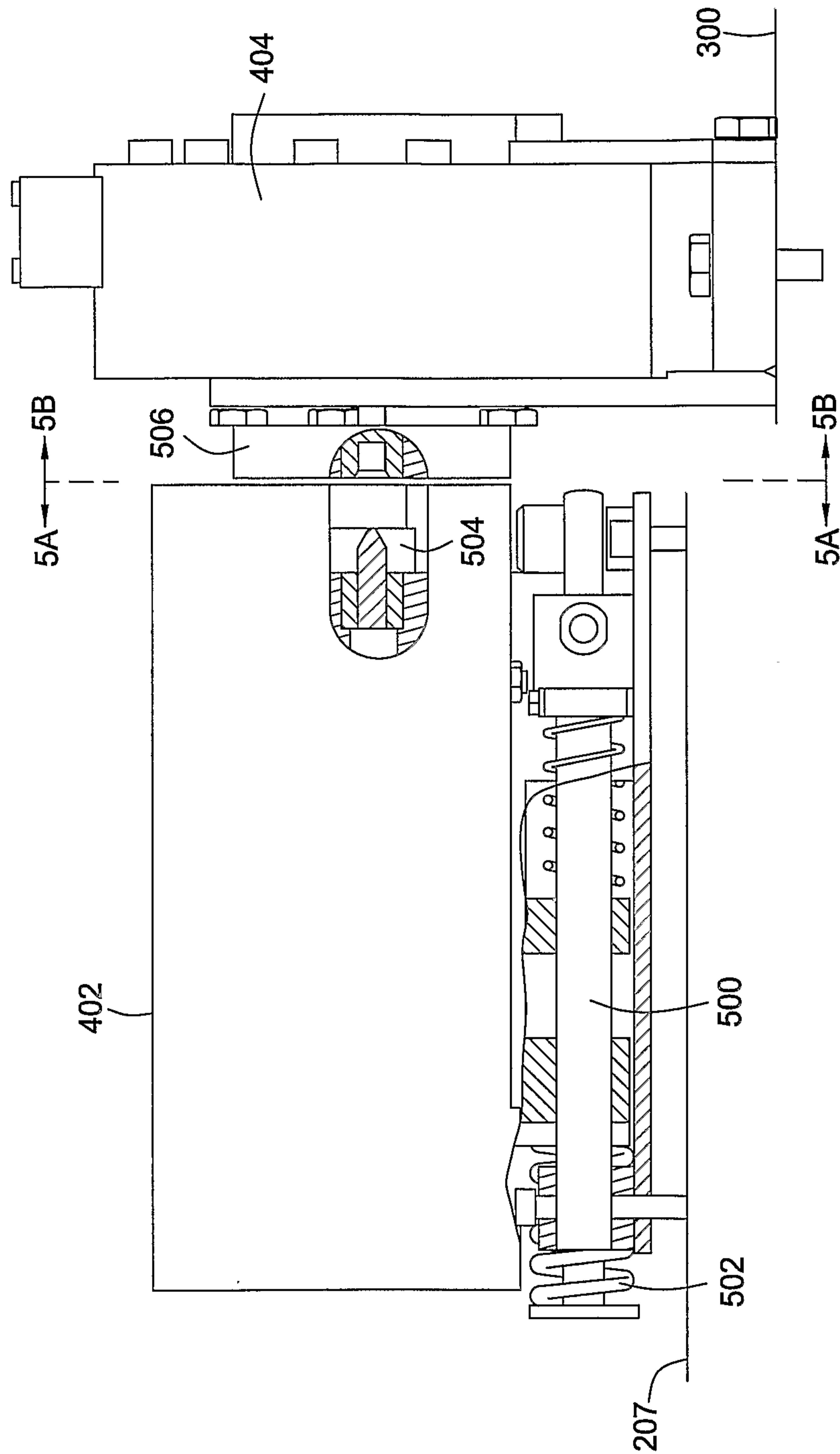

FIG. 5

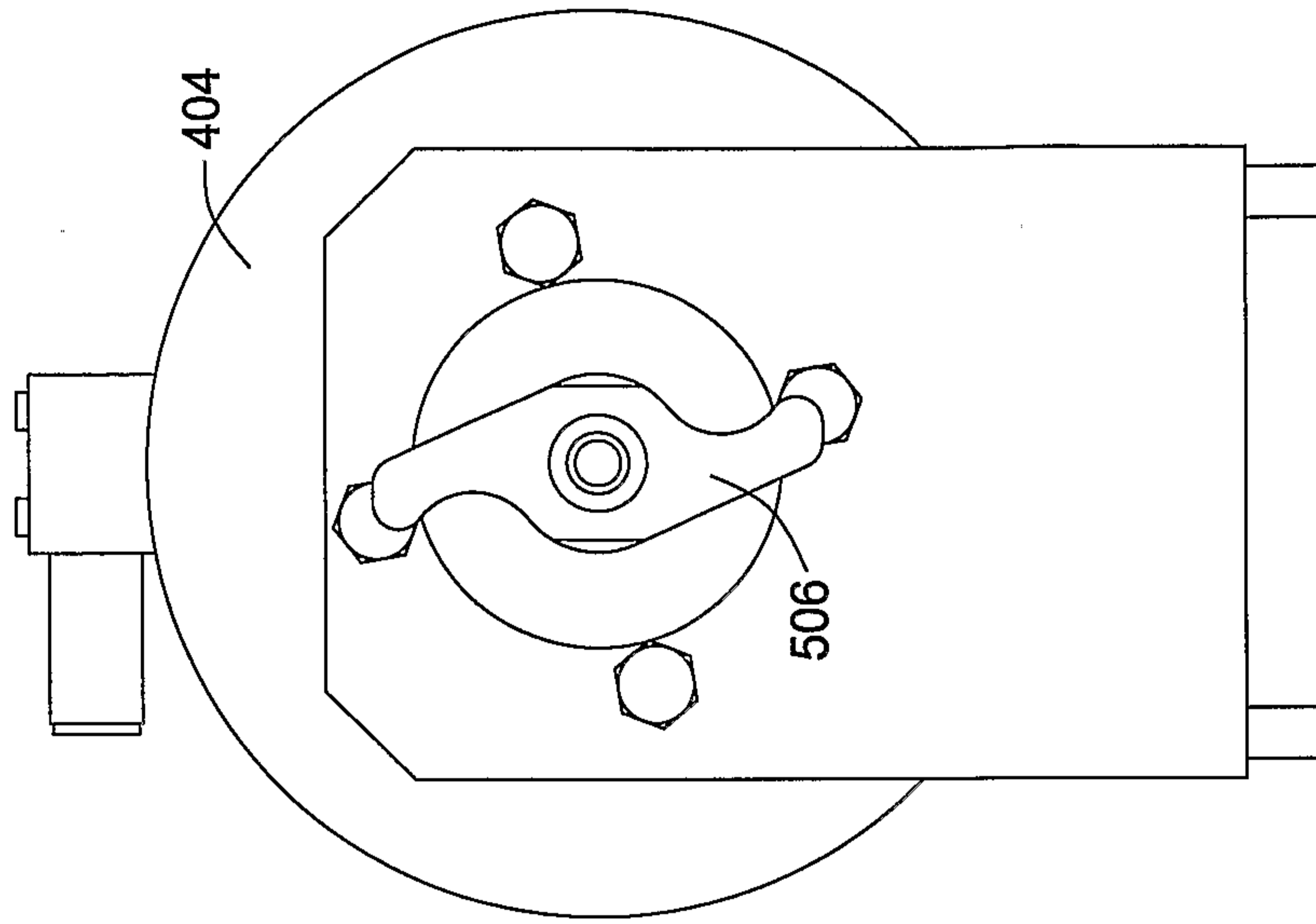

FIG. 5B

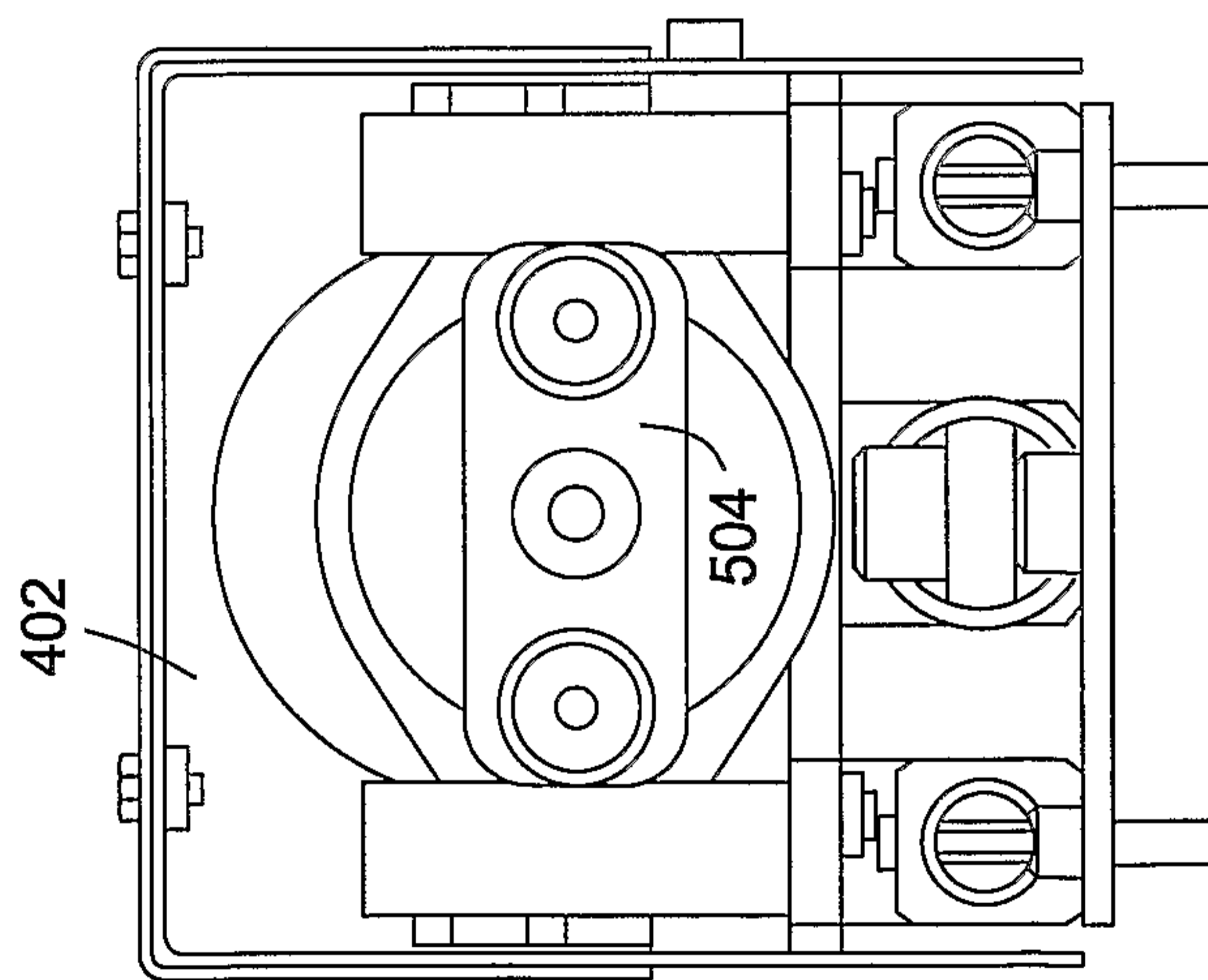

FIG. 5A

L

L

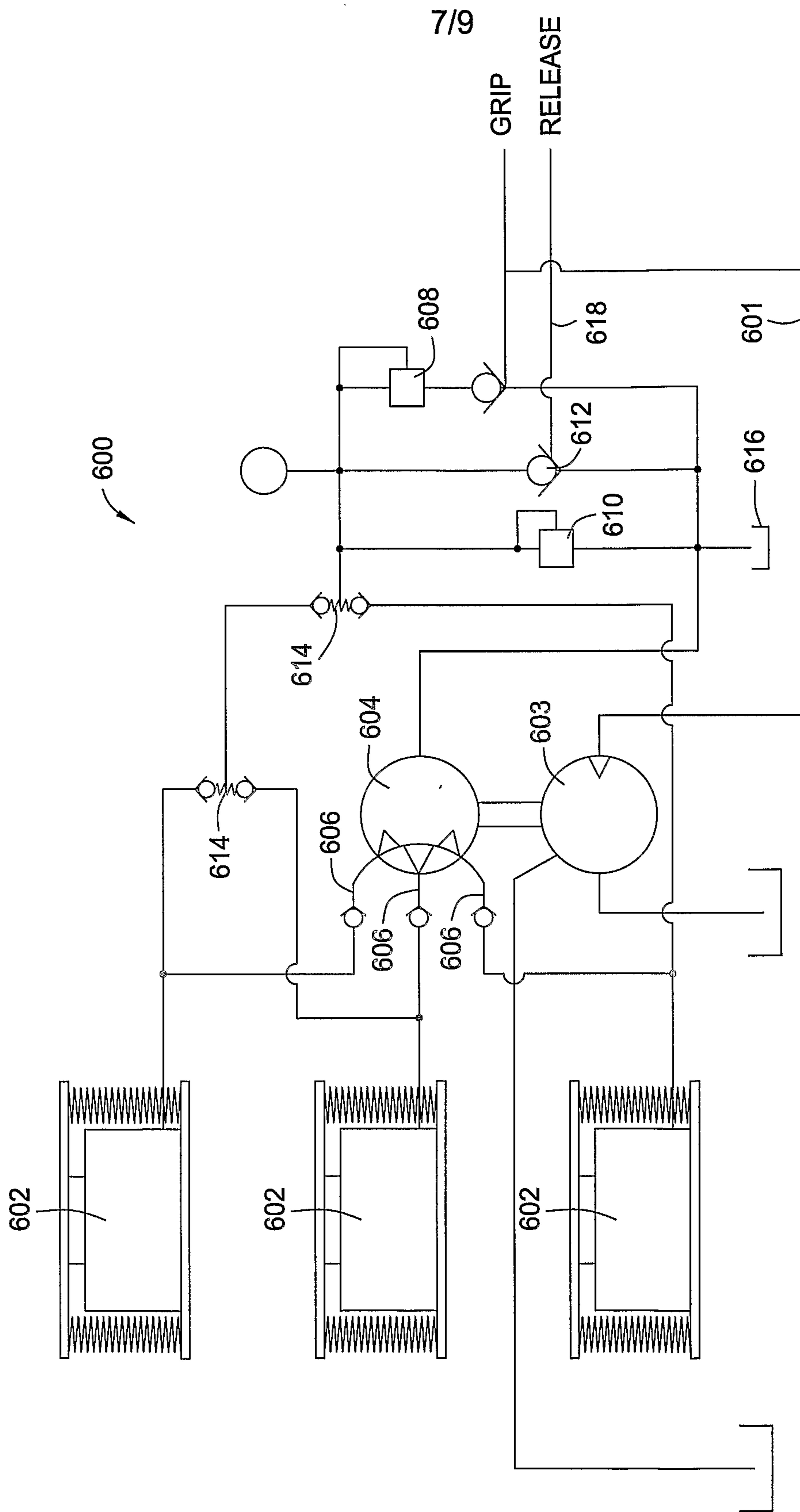

FIG. 6

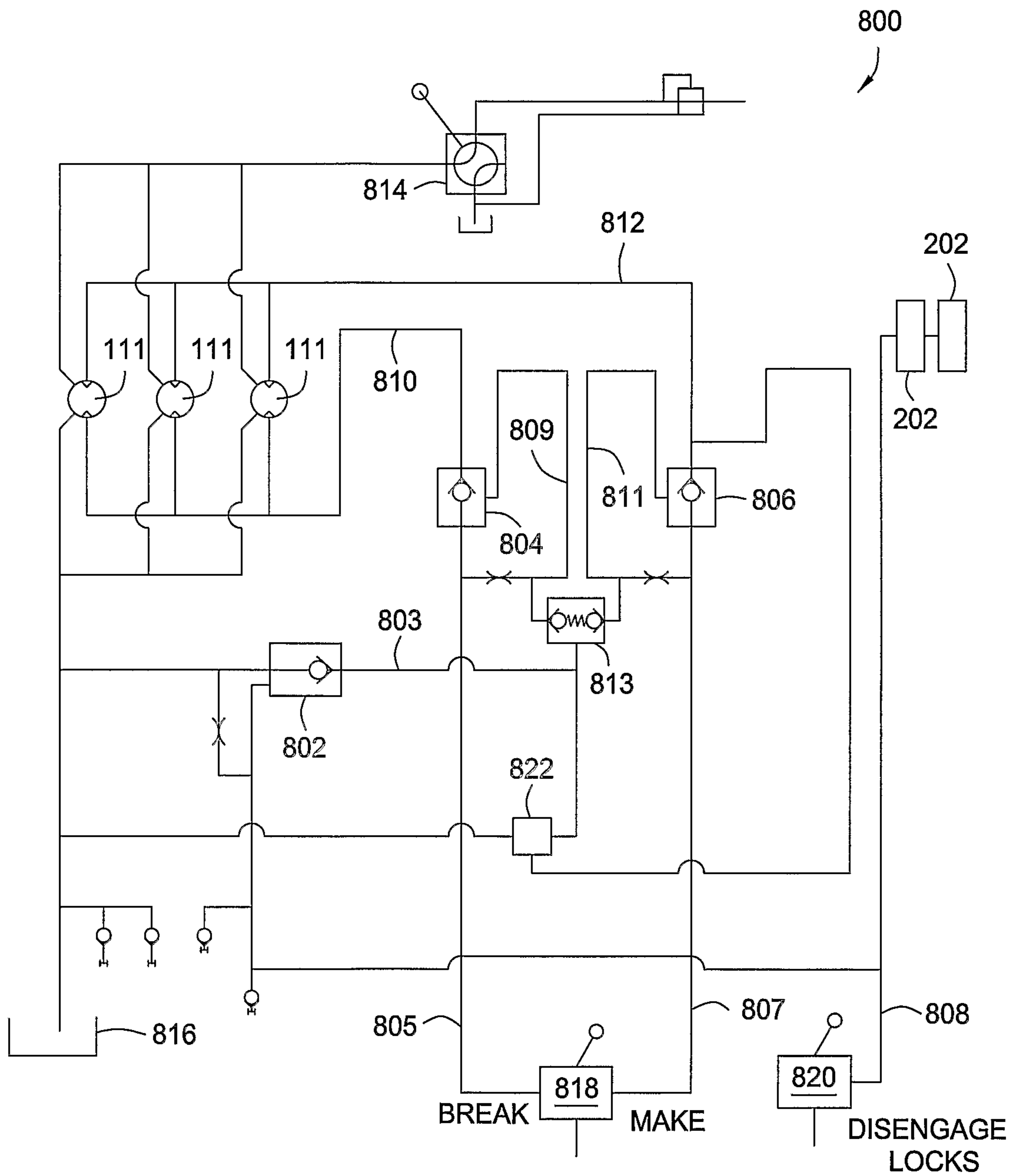

FIG. 8

