

(No Model.)

R. W. F. ABBE.  
PULVERIZING MACHINE.

No. 496,031.

Patented Apr. 25, 1893.

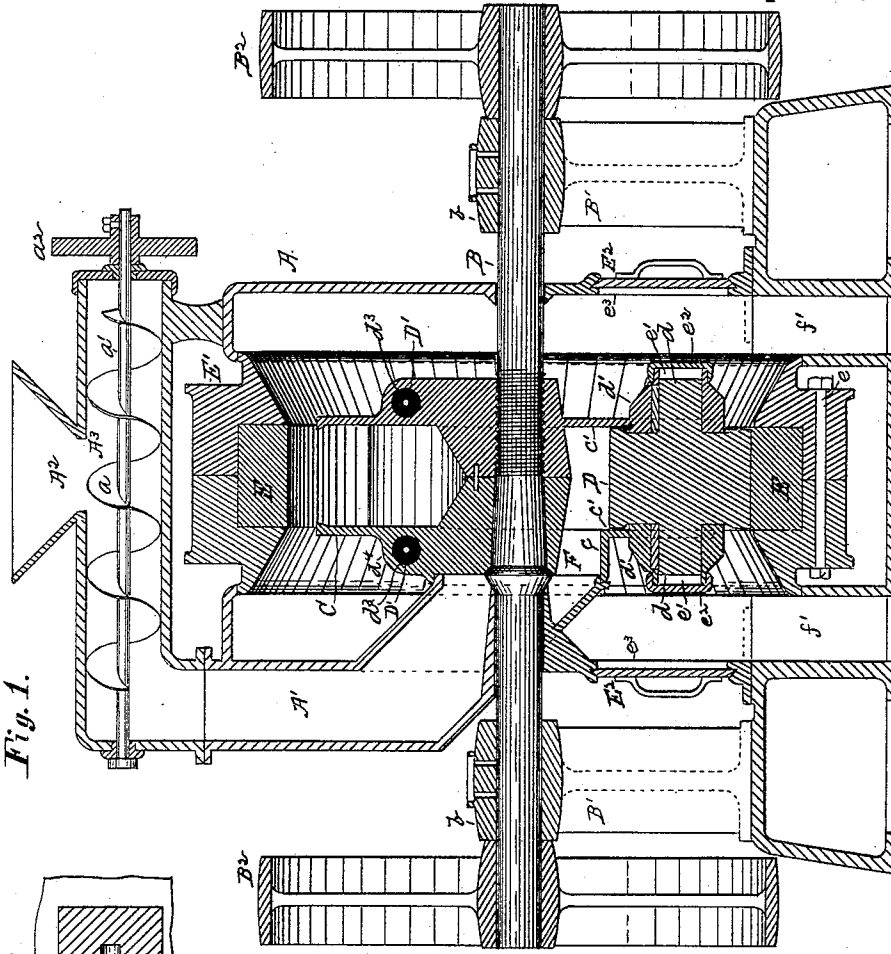

Fig. 1.

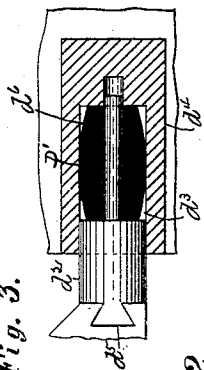

Fig. 3.

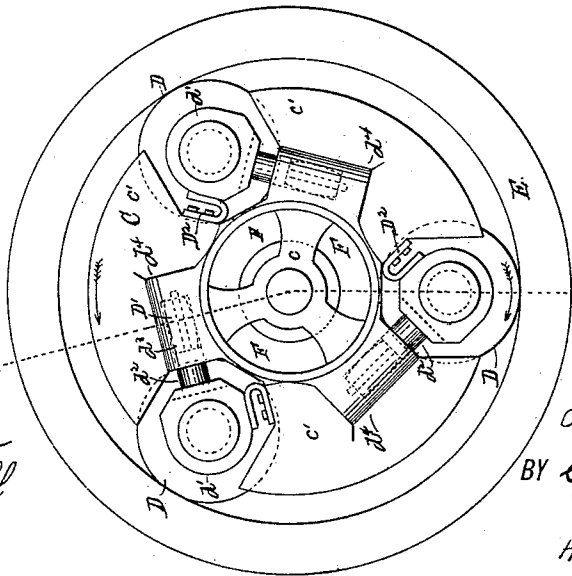

Fig. 2.

WITNESS:  
*Chas. Ferguson*  
*Wm. M. Cliff*

INVENTOR  
*Richard W. F. Abbe*  
BY *Gifford & Thayer*  
HIS ATTORNEYS

# UNITED STATES PATENT OFFICE.

RICHARD W. F. ABBE, OF BELLEVILLE, NEW JERSEY.

## PULVERIZING-MACHINE.

SPECIFICATION forming part of Letters Patent No. 496,031, dated April 25, 1893.

Application filed March 12, 1890. Serial No. 343,670. (No model.)

*To all whom it may concern:*

Be it known that I, RICHARD W. F. ABBE, of Belleville, county of Essex, and State of New Jersey, have invented a new and useful Improvement in Pulverizing-Machines, of which the following is a specification.

I will describe a pulverizing machine embodying my improvement and then point out the novel features in claims.

In the drawings, Figure 1 is a vertical section of a pulverizing machine embodying my invention taken through the line  $xx$  of Fig. 2. Fig. 2 is a side view of a grinding surface and disks employed therein. Fig. 3 is a detail. Similar letters of reference designate corresponding parts in all the figures.

The invention consists in the construction and novel arrangements of parts as hereinafter set forth.

Referring by letter to the drawings, A designates a casing or shell, substantially rectangular in form and consisting of suitable metal.

A' is a chute for material to be pulverized extending across the top and down one side of the casing to its center, and opening through the casing. A hopper A<sup>2</sup> opens into the chute and I provide a conveyer A<sup>3</sup> within the upper or longitudinal portion of the chute.

The conveyer A<sup>3</sup> is here shown as consisting of a worm  $a$  mounted on a rotary shaft  $a'$  having bearings in the end walls of the chute and having a pulley  $a^2$  on one of its ends to which power may be applied to rotate the shaft and conveyer.

B designates a main shaft extending through the casing and having bearings in boxes  $b$  at the upper end of pillars B'. Driving wheels B<sup>2</sup> are secured to the shaft B. I prefer to employ two driving wheels B<sup>2</sup>, but it is to be understood that one of them may be omitted.

C designates a rotary part consisting of a wheel secured to and rotating with the main shaft B. This rotary part has a hollow hub  $c$  and pairs of webs or plates  $c'$  integral therewith and extending outwardly from the periphery of the hub.

D shows rotary pulverizing or crushing rollers arranged between the webs  $c'$  and having their trunnions  $d$  journaled in bearing blocks  $d'$ .

The rollers D are designed to have a yield-

ing pressure on the material to be pulverized and as a means therefor I have shown the bearing blocks  $d'$  as provided with stems  $d^2$  which extend into sockets  $d^3$  arranged in projections  $d^4$  on the webs  $c'$  at right angles to the axis of the hub. The stem  $d^2$  may be integral with its bearing block  $d'$  or as shown in the drawings the block may be detachably secured to the stem. As a convenient means for detachably connecting the block to the stem the stem may be provided on its end with a dovetail rib  $d^5$  to fit within a corresponding groove in one side of the bearing block.

D' designates a yielding bed within the socket  $d^3$ , bearing at one end against the end of the stem  $d^2$  and surrounding a reduced portion  $d^6$  of the stem. I prefer to employ rubber for this yielding bed D' and to allow for its expansion when pressure is brought to bear upon it the ends are somewhat smaller in circumference than the central portion. It is obvious that other material may be used for this yielding bed, such for instance as spring metal, without departing from the spirit of my invention. Springs D<sup>2</sup> secured at one end to the webs  $c'$  bear upon the bearing blocks  $d'$  and serve to steady the rollers.

E designates an annular pulverizing surface upon the inner surface of which the rollers D bear. This pulverizing surface is shown as a metal ring rigidly fixed within a clamping ring E' within the casing. The ring E' is made in two parts secured together by rivets or bolts  $e$ .

The bearing blocks  $d'$  are provided with spaces  $e'$  for a packing or other lubricant, and caps  $e^2$  engage threaded portions on the blocks to retain the lubricant within the space.

The case A is provided on two sides with an opening  $e^3$  within the line of rotation of the pulverizing rollers and a cover E<sup>2</sup> is provided for each of the openings. These covers are shown as sliding in grooves in ribs extended outwardly from the case. The openings  $e^3$  provide a convenient means of reaching the bearing blocks when it is desired to lubricate the parts or place a new packing therein.

It will be seen that the chute A' communicates with the interior of the rotary part C through openings F in the hub. The material to be pulverized or crushed, therefore,

55

60

65

70

75

80

85

90

95

100

passes from the chute into the rotary part and falls upon the pulverizing wheels. The powdered material is forced outwardly to the sides of the rotary part and passes through openings *f'* in the lower portion of the casing into a receptacle provided to receive it.

Having described my invention, what I claim is—

1. In a pulverizer the combination with a fixed casing and an annular pulverizing surface therein, of a main shaft, a rotary part secured to the main shaft having a hollow hub into which material to be ground passes, pairs of webs extending from and carried by said hub, rotary pulverizing rolls arranged between the webs and having yielding bearings in projections on the webs at right angles to the axis of the hub, substantially as specified.

2. In a pulverizer the combination with a casing, an annular pulverizing surface fixed therein and a main shaft, of a rotary part on the main shaft consisting of a wheel having a hollow hub for receiving material to be pulver-

ized, and pairs of webs extending therefrom, pulverizing rollers between the webs, bearing blocks for the rollers having spaces for packing and caps engaging threaded portions of the blocks, stems detachably secured to the bearing blocks and projecting into sockets in the rotary part and a yielding bed in the sockets, substantially as specified.

3. In a pulverizer the combination with a fixed casing, an annular pulverizing surface therein and a main shaft, of a rotary part secured to the main shaft and consisting of a hollow hub having pairs of webs extending therefrom, rotary pulverizing rollers arranged between the webs and having yielding bearings in projections on the webs at right angles to the axis of the hub and springs secured at one end to the webs and bearing upon the bearing blocks of the rollers, substantially as specified.

RICHARD W. F. ABBE.

Witnesses:

C. R. FERGUSON,  
S. O. EDMONDS.