

B. F. MAYO.
 SOLE PRESSING MACHINE.
 APPLICATION FILED MAR. 10, 1906.

997,927.

Patented July 11, 1911.

5 SHEETS—SHEET 1.

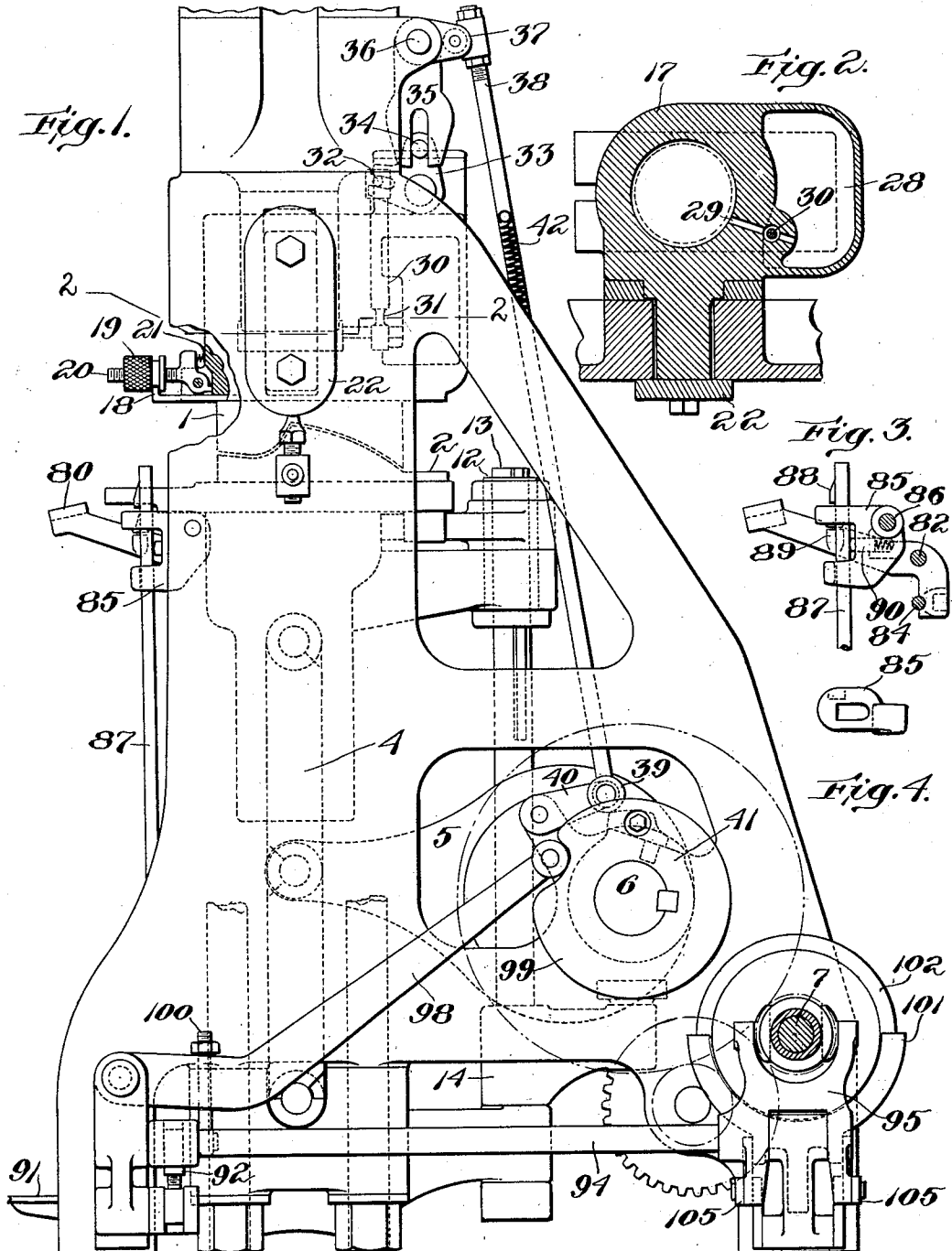

Witnesses:
 Sarnum F. Dorey
 A. C. Richardson.

Inventor:
 Benjamin F. Mayo
 by his Attorneys
 Phillips Van Coven & Fish

997,927.

Patented July 11, 1911.

5 SHEETS—SHEET 2.

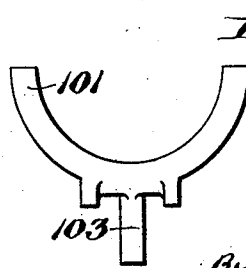
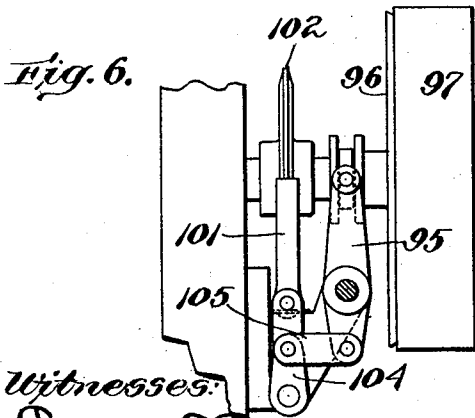
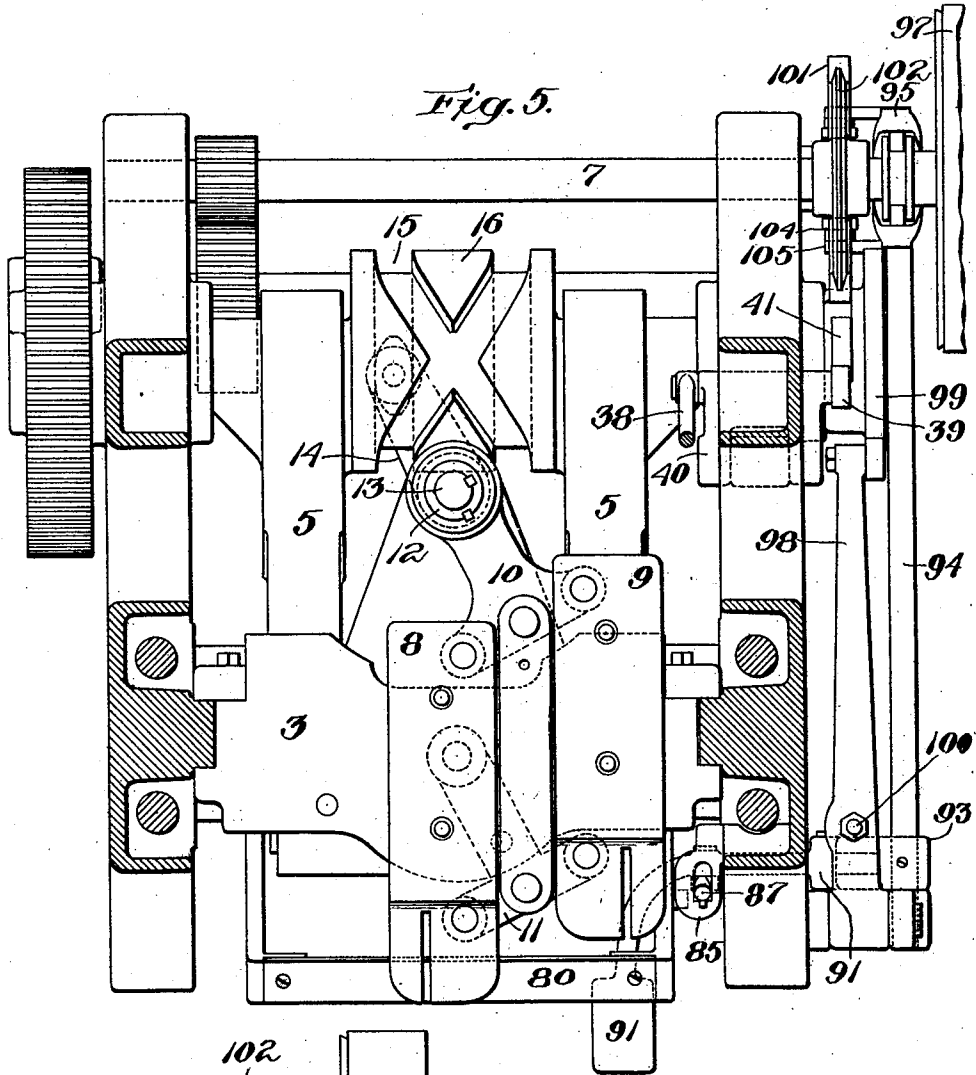

Witnesses:
 Samuel F. Dorsey
 A. C. Richardson.

Inventor:
 Benjamin F. Mayo
 by his Attorneys
 Phelps Van Coven & Fish

B. F. MAYO.
SOLE PRESSING MACHINE.
APPLICATION FILED MAR. 10, 1906.

997,927.

Patented July 11, 1911.

5 SHEETS—SHEET 3.

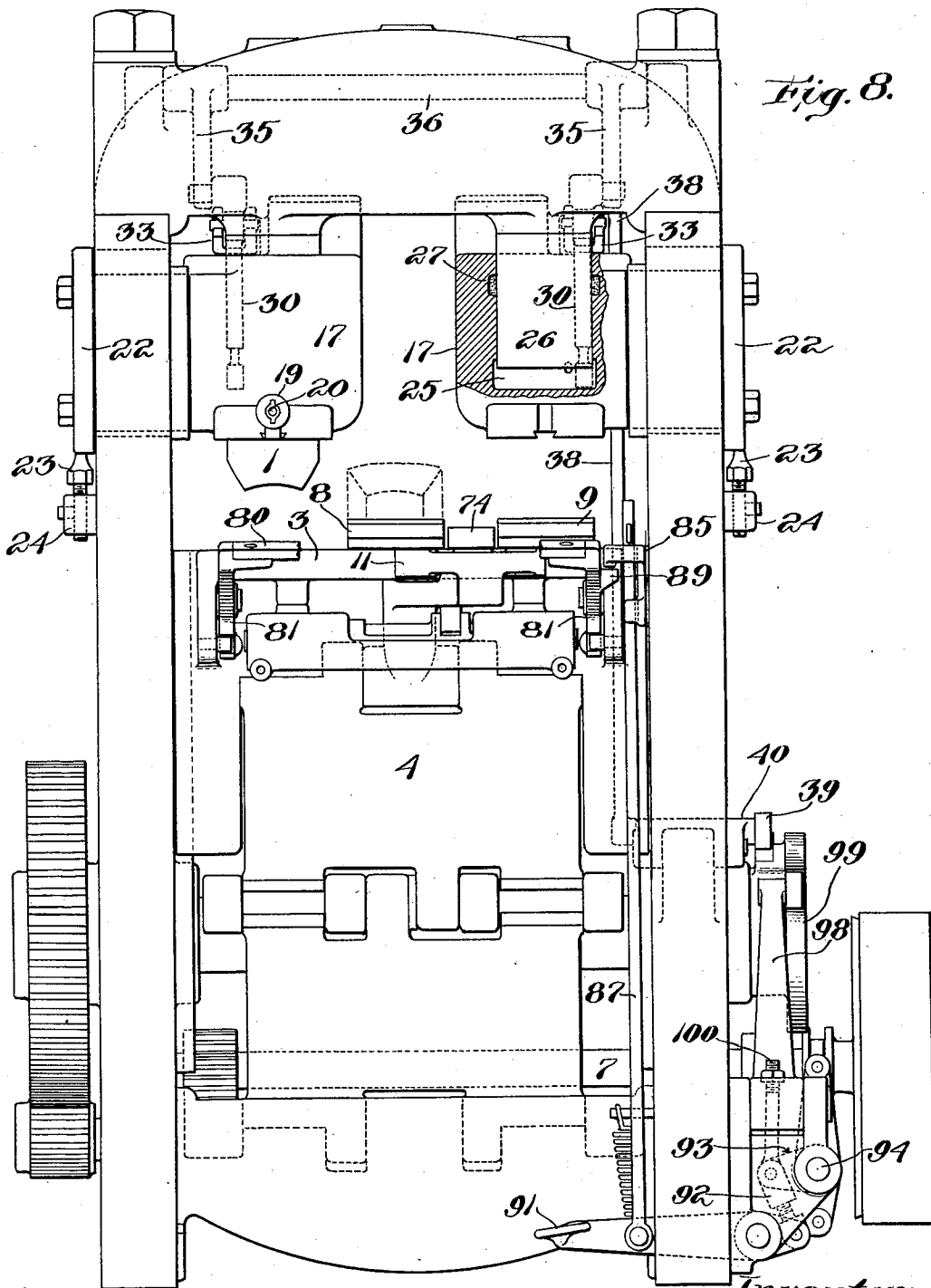

Fig. 8.

Witnesses:
Farnum F. Dorsey
A. C. Richardson.

Inventor:
Benjamin F. Mayo
By his Attorneys
Phillips Van Eversen & Fish

B. F. MAYO.
 SOLE PRESSING MACHINE.
 APPLICATION FILED MAR. 10, 1906.

997,927.

Patented July 11, 1911.

5 SHEETS—SHEET 4.

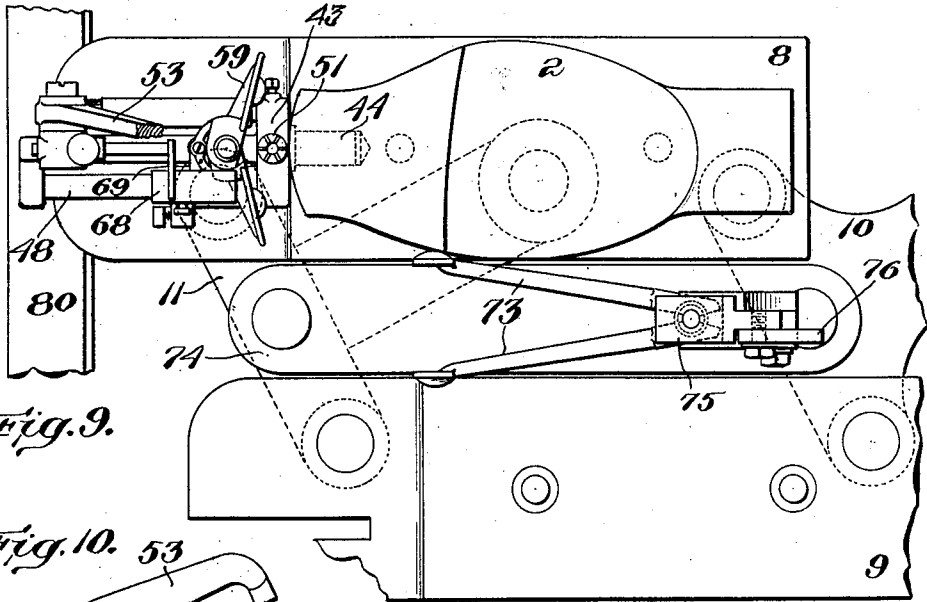

Fig. 9.

Fig. 10.

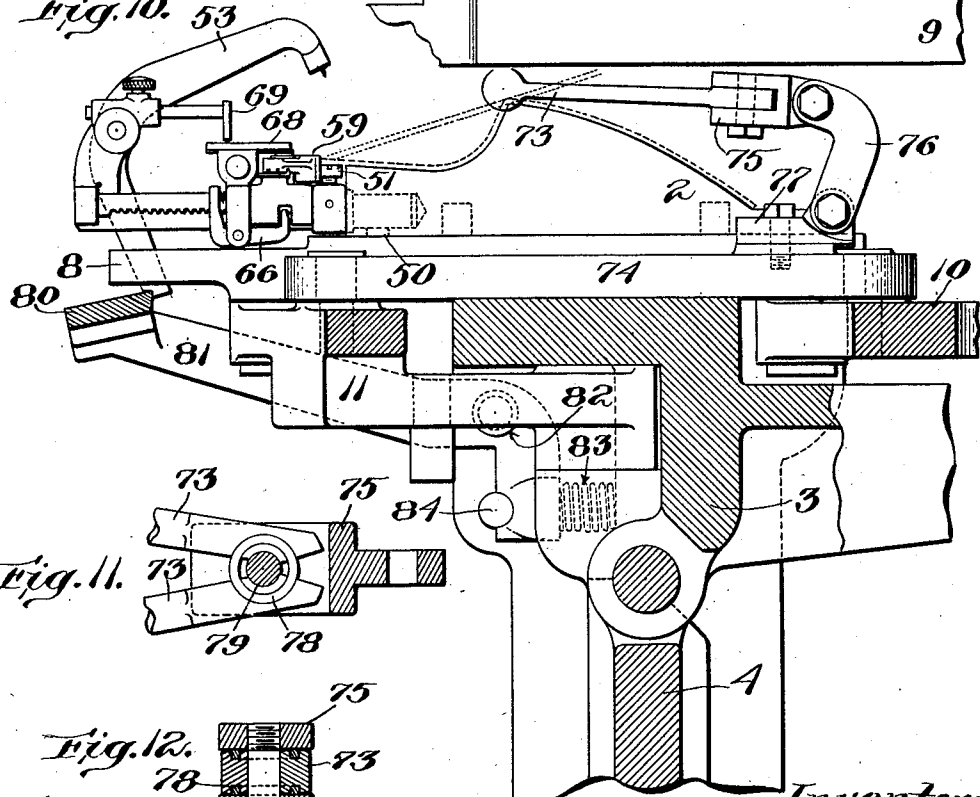

Fig. 11.

Fig. 12.

Witnesses:
 Samuel J. Dorsey
 W. C. Richardson.

Inventor:
 Benjamin F. Mayo
 by his Attorneys
 Phillips Van Curen & Fish

B. F. MAYO.
 SOLE PRESSING MACHINE.
 APPLICATION FILED MAR. 10, 1906.

997,927.

Patented July 11, 1911.

6 SHEETS—SHEET 5.

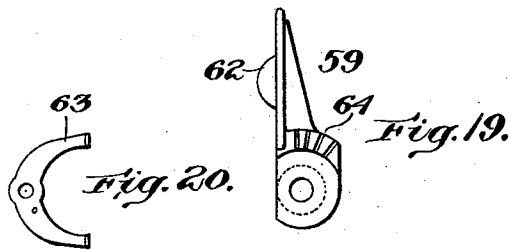
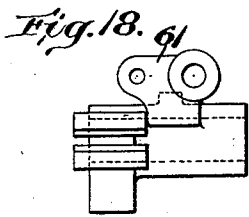
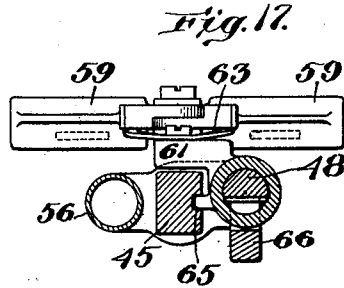
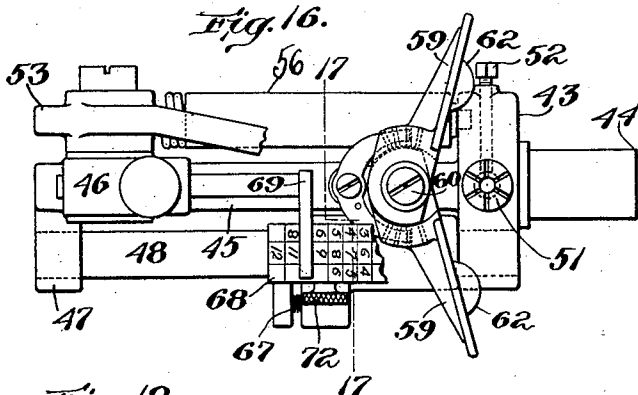
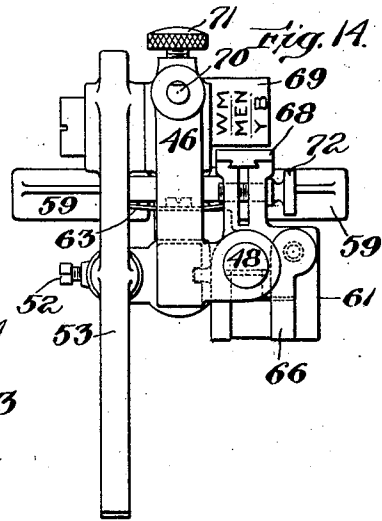
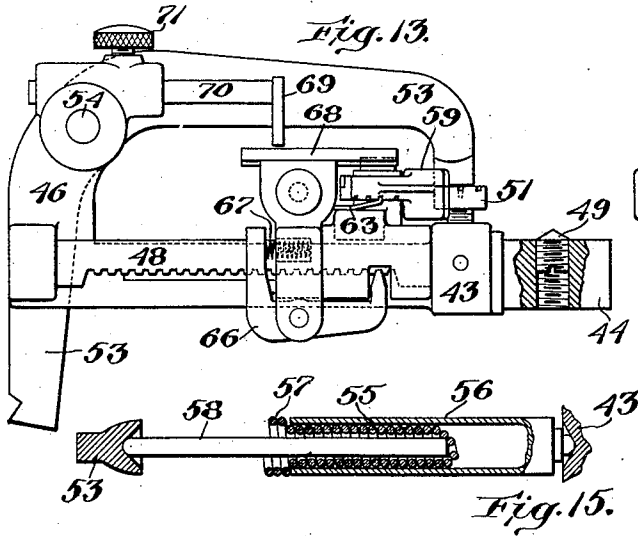

Witnesses:
 Farnum F. Dorsey
 A. C. Richardson.

Inventor:
 Benjamin F. Mayo
 by his Attorneys
 Phillips Van Curen & Fish

UNITED STATES PATENT OFFICE.

BENJAMIN F. MAYO, OF SALEM, MASSACHUSETTS, ASSIGNOR TO UNITED SHOE MACHINERY COMPANY, OF PATERSON, NEW JERSEY, A CORPORATION OF NEW JERSEY.

SOLE-PRESSING MACHINE.

997,927.

Specification of Letters Patent.

Patented July 11, 1911.

Application filed March 10, 1906. Serial No. 305,231.

To all whom it may concern:

Be it known that I, BENJAMIN F. MAYO, a citizen of the United States, residing at Salem, in the county of Essex and State of Massachusetts, have invented certain new and useful Improvements in Sole-Pressing Machines; and I do hereby declare the following to be a full, clear, and exact description of the invention, such as will enable others skilled in the art to which it appertains to make and use the same.

The present invention relates to sole pressing machines and more particularly to sole pressing machines adapted for operation upon soles before they are incorporated in a shoe.

The object of the present invention is to provide a sole molding machine with improved sole gaging and sole gripping devices whereby the soles which are presented to the machine may be accurately positioned with respect to the molds and be held from displacement during the action thereon of the molds.

With this object in view the present invention consists in certain improved constructions and arrangements of parts hereinafter described and claimed, the advantages of which will be obvious to those skilled in the art from the following description.

The several features of the present invention will be clearly understood from an inspection of the accompanying drawings, in which—

Figure 1 is a view in side elevation of a sole molding machine embodying the same in their preferred form, the sole gripping and gaging devices being omitted and the driving shaft being shown in section; Fig. 2 is a detail sectional plan view taken on line 2—2 of Fig. 1, illustrating a portion of a pressure regulating mechanism; Fig. 3 is a detail view in side elevation of a portion of the mechanism for tripping the sole gripping jaws; Fig. 4 is a detail plan view of a block forming a portion of the mechanism illustrated in Fig. 3; Fig. 5 is a sectional plan view of the machine taken on a line passing between the upper and lower sole molding forms with the lower forms removed from their carriers; Fig. 6 is a detail view illustrating the construction of a brake mechanism; Fig. 7 is a detail view of the

brake shoe forming a part of the brake mechanism illustrated in Fig. 6; Fig. 8 is a view in front elevation partly in section of the machine, one of the upper forms and both of the lower forms being removed from the machine the position of one of the lower forms being indicated in dotted lines, and a portion of the stop bar for opening the gripping jaws being broken away; Fig. 9 is a detail plan view illustrating the construction and arrangement of the carriers for the lower forms, the side gages, and the sole gripping and heel gaging devices, one of the lower forms with its attached sole gripping and heel gaging devices being removed; Fig. 10 is a detail sectional view taken on a line passing through the center of the machine showing the construction and arrangement of the parts illustrated in Fig. 9, and also the vertically reciprocating cross-head upon which the form carriers are mounted, and the stop bar for-actuating the sole gripping jaws; Fig. 11 is a detail sectional plan view of the frictional joint at the rear ends of the side gages; Fig. 12 is a cross sectional view of the joint illustrated in Fig. 11; Fig. 13 is a view in side elevation of one set of sole gripping and heel gaging devices and of the carrier upon which these devices are mounted; Fig. 14 is a view in rear elevation of the parts illustrated in Fig. 13; Fig. 15 is a detail sectional view illustrating the construction and arrangement of the spring by which the movable sole gripping jaw is actuated to grip the sole; Fig. 16 is a plan view of the parts illustrated in Fig. 13, with the front portion of the movable sole gripping jaw broken away; Fig. 17 is a cross-sectional view taken on the line 17—17, Fig. 16; Fig. 18 is a detail view of the adjustable block which carries the heel gage and the indicator plate; Fig. 19 is a bottom plan view of one of the arms of the heel gage; and Fig. 20 is a plan view of the spring which holds the two arms of the heel gage in adjusted position.

Except for the sole gaging and sole gripping devices which constitute the illustrated embodiment of the essential features of the present invention and except for the pressure regulating mechanism which constitutes the subject matter of an application executed of even date herewith, the machine

illustrated in the drawings is quite similar in construction and mode of operation to the machine disclosed in Patent No. 918,573, dated April 20, 1909, being provided with
 5 two upper sole molding forms, two lower cooperating sole molding forms, means for moving the lower forms simultaneously toward and from the upper forms and means for moving the lower forms alternately to
 10 a position of presentation in front of and between the upper forms.

In Fig. 1 an upper form is indicated at 1 and a lower form at 2, the forms being adapted to receive a flat sole between them
 15 and to mold the sole into the desired shape, and the male form being below and the female form above. The lower forms are supported upon a vertically reciprocating cross-head 3 which is reciprocated in guide-
 20 ways in the frame of the machine by means of a toggle lever 4, eccentric straps and links 5, and eccentrics on a shaft 6 journaled in the rear portion of the machine frame, and driven through a series of gears from the
 25 power shaft 7. The lower forms are supported on the cross-head 3 by means of form carriers 8 and 9 which rest upon the flat upper surface of the cross-head. The rear ends of the form carriers are pivotally connected to a T-shaped arm 10 pivotally
 30 mounted in a rearward extension of the cross-head 3 and the forward ends of the form carriers are pivotally connected to a T-shaped arm 11 pivoted to the cross-head, the arm 10 being located at the rear end of the table forming the upper portion of the
 35 cross-head and the arm 11 extending beneath the table. To swing the arms 10 and 11 a swinging movement is imparted to the arm 10, and to this end the arm is keyed to a sleeve 12 mounted to turn in the rearward extension from the cross-head 3 and the sleeve 12 is provided with a slot engaged by a spline on a vertical shaft 13
 40 which passes through the sleeve and upon which the sleeve is adapted to slide vertically. Near its lower end the shaft 13 is provided with a rearwardly extending arm 14, on which is pivotally mounted a block
 45 which engages a cam groove 15 in a cam 16 secured to the shaft 6. This cam groove is shaped as indicated in Fig. 5, and during one rotation of the shaft 6 acts to swing the arm 10 in one direction, and during the
 50 next rotation of the shaft to swing the arm in the opposite direction. The lower forms are thus brought alternately into alinement with their cooperating forms and during each reciprocation of the cross-head one of the lower forms is in alinement with its cooperating form while the other lower
 55 forms is in a position of presentation in front of and between the two upper forms.

Each upper form is mounted in a carrier
 60 17 and is removably secured thereto by

means of a dove-tail strap 18 secured to the form and received in a slot in the lower surface of the carrier. The form is held in position after being placed on the carrier by
 70 means of a nut 19 provided with a groove which engages an upturned flange at the front end of the strap 18 and having a screw-threaded engagement with a rod 20 projecting from an arm pivotally mounted
 75 upon the carrier 17 and acted upon by a coiled spring 21, the screw-threaded engagement of the nut 19 with the rod 20 permitting a longitudinal adjustment of the upper form to bring it into the proper position with relation to its cooperating lower form.
 80 The carriers 17 for the two upper forms are mounted independently of each other in vertical guideways in the sides of the machine frame and are held in said guides by means of plates 22 secured to the carriers and engaging the outer surfaces of the sides of the machine frame. Beneath the plates 22 adjustable stop bolts 23 are provided, mounted in projections 24 from the machine frame, and adapted to limit the downward movement of the form carriers. By adjusting these stop bolts the form carriers can be raised so that the lower forms do not come in contact with the upper forms when the cross-head carrying the lower forms is at the limit of its upward movement. The upper and lower forms can thus be kept out of engagement with each other while the machine is idle and injury to the forms or to the other parts of the machine avoided.
 90 95 100

In molding a sole, one the lower forms is moved toward its cooperating upper form to exert first a preliminary pressure upon the sole sufficient in amount to cause the sole to conform to the shape of the forms
 105 and thereafter a final pressure sufficient in amount to mold the sole. While the preliminary pressure is being applied, the form carrier 17 moves upwardly and while the final pressure is being applied the form carrier 17 is locked against movement. To enable the proper amount of pressure to be exerted upon the sole regardless of its thickness, a fluid pressure mechanism is provided which acts to permit the form carrier
 110 115 120 125 130 17 to move upwardly varying distances depending upon the thickness of the sole and which then locks the form carrier against movement. This fluid pressure mechanism as illustrated in the drawings comprises a pressure chamber or cylinder 25 formed in the form carrier, a piston 26 secured to the stationary cross-head forming the upper portion of the machine frame and extending into the cylinder, a packing 27
 125 130 between the wall of the pressure chamber and the piston, an overflow chamber or reservoir 28 formed in the form carrier, a passage way 29 connecting the pressure chamber and the reservoir, and a valve rod 30

provided with a reduced portion 31, adapted to open and close the passage way. The pressure chamber 25 and reservoir 28 are provided with oil or other suitable fluid which flows through the passage way 29 while the passage way remains open and permits the form carrier 17 to be raised and lowered. During the greater portion of the upward movement of the lower form the passage way 29 remains open and thus the upper form is allowed to yield when the sole on the lower form is brought into contact therewith, a sufficient pressure, however, being exerted upon the sole, before the form carrier 17 begins to move upwardly, to cause the sole to conform to the shape of the forms. At a predetermined point in the upward movement of the lower form the valve rod 30 is actuated to close the passage way 29 and thus the fluid which remains in the pressure chamber 25 is prevented from escaping and the upward movement of the form carrier 17 is stopped.

Each valve rod 30 is actuated from the cam shaft 6 at the proper time during the operation of the machine, as follows:—At its upper end, each valve rod is provided with a laterally projecting pin 32 which engages a slot in the horizontal arm of a bell crank 33. The vertical arms of the bell cranks 33 are provided with laterally extending pins 34 which engage slots in arms 35 secured to a shaft 36 journaled in the upper rear portion of the machine frame. From the shaft 36 an arm 37 extends rearwardly and is pivotally connected to the upper end of a rod 38. The lower end of the rod 38 is pivotally connected to an arm 40, pivoted in the frame of the machine, and at the pivotal connection of the rod 38 and arm 40 a roll 39 is provided which is arranged in the path of movement of a cam projection secured to a cam disk 41 upon the shaft 6. The projection of the cam 41 acts to raise the rod 38 and through the connections above described raises both valve rods 30 to close the passage ways 29. The bell crank levers 33 are mounted upon the form carriers 17 and as the form carriers are raised and lowered the pins 34 on the bell cranks traverse the slots in the arms 35. When the valve rods are in their raised positions the pins 34 and the slots in the arms 35 are in line with the axis of the shaft 36 and the pivots of the bell cranks 33 as is clearly shown in Fig. 1 and thus the valve rods are actuated at a predetermined time in the operation of the machine irrespective of the positions of the form carriers. A spring 42 connected to the rod 38 acts to hold the roll 39 in contact with the cam disk 41.

The sole gripping and sole gaging devices of the machine illustrated in the drawing comprise a sole gripping device, a heel

gage and a side gage associated with each lower form. In the drawings both side gages are illustrated, but only one heel gage and sole gripping device, it being understood that the heel gage and sole gripping device associated with the other lower form are the duplicates of those illustrated. The heel gage and sole gripping devices associated with each lower form are mounted upon a carrier consisting of a front portion 43 in the form of a cross-head, a stud 44 projecting from one side of the cross-head, a central bar 45 projecting from the other side of the cross-head and provided at its end with an upward projection 46 and a lateral projection 47, and a side rod 48 mounted at its ends in the projection 47 and in one end of the cross-head 43. This carrier is removably secured to the lower mold by means of the stud 44 which enters a hole in the heel end of the lower form and by means of a set screw 49 threaded in the stud 44 and provided with a pointed end adapted to enter a recess in the form. The set screw 49 is turned after the stud 44 has been inserted in the hole in the form by means of a screw driver inserted through a transverse hole 50 in the form, which hole is indicated in dotted lines in Fig. 10.

The sole gripping device consists of two jaws which are arranged to engage opposite surfaces of the sole and grip the sole between them. One of the sole gripping jaws is indicated at 51 and is formed by the head of a screw mounted in the cross-head 43. The upper surface of the gripper 51 is provided with grooves as indicated in Figs. 13 and 16, which grooves serve to roughen the surface of the jaws and also provide a means by which the jaw can be rotated to adjust it vertically, a vertical adjustment of the jaw being desirable to bring it into the plane of the heel portion of the form with which the sole gripping and heel gaging devices are used. The stationary jaw 51 is held in adjusted position by means of a set screw 52. The other jaw of the sole gripping device is indicated at 53, and consists of a lever pivotally mounted upon a stud 54 in the upper end of the projection 46. The rear end of the lever 53 projects downwardly and is acted upon by a spring 55 which is arranged to swing the lever 53 in a direction to move its forward end toward the stationary gripping jaw 51. The spring 55 is supported in a sleeve 56, as illustrated in Fig. 15, and is provided at its outer end with an enlarged portion which bears against one end of the sleeve. The force of the spring is transmitted to the lever 53 by means of a rod 58 which extends through the spring and is interposed between the inner end of the spring and the downwardly extended portion of the lever 53. The sleeve 56 is supported in position by means of the

rod 58 and by means of a projection at one end of the sleeve which engages a recess in the cross-head 43. The lever 53 is actuated to open the gripping jaws by means of a stop bar hereinafter described, with which the downwardly extended portion of the lever contacts, and is actuated by the spring 55 to close the gripping jaws when the stop bar is disengaged from the lever.

The heel gaging device illustrated in the drawings comprises two arms 59 pivotally mounted upon a stud 60 projecting from a block 61. These arms are provided with vertical surfaces to engage the edge of the heel portion of the sole and are also provided with horizontally projecting sole supports 62 which are adapted to extend beneath the sole and assist the stationary gripping jaw 51 in supporting the sole in proper position with relation to the mold. To adapt the gage for use with soles of different shapes, or with a sole the heel portion of which has not been trimmed or rounded, the arms 59 are movably mounted so that the arms may be placed in line with each other or in different angular positions with relation to each other. To hold the arms in their adjusted positions, a leaf spring 63, illustrated separately in Fig. 20, is provided, which spring is secured at its central point to the block 61 and arranged with its upturned ends in position to enter slots 64 formed on the under surfaces of the arms 59.

In molding soles it is customary to use the same set of molds for several sizes of soles, and in order to permit the heel gage to be placed in the proper position with relation to the mold for soles of different sizes the block 61, which carries the heel gage, is adjustably mounted upon the carrier. The block 61 is supported upon the rod 48 which passes through a sleeve-like portion of the block and the block is held from rotation on the rod 48 by means of a rib 65 projecting from the sleeve portion of the block into a longitudinal slot cut in the side of the central bar 45. The block is adjusted on the carrier by moving it longitudinally on the rod 48 and is held in adjusted position by means of a latch 66 pivotally mounted in the block and arranged to engage a series of teeth cut in the bar 48. A spring 67 acting upon the latch holds the latch in engagement with the teeth after the block has been adjusted.

To assist the operator in adjusting the heel gage an index plate 68 is secured to the block 61 and a pointer 69 is provided in the form of a plate extending across the plate 68 and supported from the projection 46 on the carrier by means of a rod 70.

The heel gaging and sole gripping devices are designed for use in connection with any one of a series of forms of different sizes and styles. The lower forms are removably

mounted upon their carriers as is common in sole molding machines and since the heel gaging and sole gripping devices are mounted upon carriers which are secured to the forms these devices are bodily removable with the forms and can be readily shifted from one form to another while the forms are out of the machine.

It will be noted that the carriers upon which the heel gaging and sole gripping devices are mounted are readily removable from the machine by reason of the fact that they are secured to the lower forms so that the machine can be used without the heel gaging and sole gripping devices whenever the operator desires or whenever work is to be operated upon for which the heel gaging and sole gripping devices are not adapted. It will also be noted that when the heel gaging and sole gripping devices are removed from the machine the position of the gage with relation to the gripping devices is not altered since they are mounted on the same carrier.

The principal operation performed by the forms of a sole molding machine is to form a sharp bend in the sole at the junction of the shank and forepart, or, as it is termed in the art, at the ball line of the sole. The heel gage is adjusted with relation to the ball line of the form and in order that the same heel gage, index plate and pointer may be used for all styles and sizes of soles a relative adjustment is provided between the index plate 68 and the pointer 69. As shown in the drawings, this relative adjustment may be accomplished by adjusting either the pointer 69 or the plate 68, the rod 70 which carries the pointer 69 being adjustably secured in the projection 46 of the carrier by means of a screw 71, and the plate 68 being adjustably secured by a set screw 72 between arms projecting from the block 61. The gage plate 68 is provided with three rows of figures, as indicated in Fig. 16, and the pointer 69 is provided with three rows of letters, as indicated in Fig. 14, corresponding to the three rows of figures on the index plate. The upper row of figures on the index plate, as shown in Fig. 16, indicate the positions for the gage when soles for women's or misses' shoes are being molded. The middle row of figures indicates the position of the gage when soles for men's shoes are being operated upon, and the lower row of figures indicates the position of the gage when soles of shoes for youths and boys are being operated upon. After the index plate and gage have been properly adjusted the heel gage can be set in the proper position for all sizes of women's, misses', men's, youths' and boys' shoes of a given style without changing the relative adjustment of the index plate and pointer. To adapt the gaging devices for operation

with soles of a different style, a relative adjustment of the index plate and gage is necessary.

The side gaging devices for the sole are indicated at 73, see particularly Figs. 9, 10, 11 and 12. One of these gages is provided for each mold and is arranged to engage the side of the sole at the forepart and preferably near the ball line of the sole. The side gages for both forms are mounted upon a link 74 connecting the two T-shaped arms 10 and 11, and located between the two form carriers 8 and 9. In order to adapt the side gages for operation with forms of any style or size which may be placed in the machine, the gages are mounted upon the link 74 so as to be adjustable vertically, horizontally and laterally with relation to the forms. In the construction illustrated in the drawings the gages 73 are pivotally mounted at their rear ends in a block 75 so as to be capable of being swung laterally, and the block 75 is pivotally mounted upon the upper end of an arm 76 the lower end of which is pivotally mounted upon a block 77 rigidly secured to the link 74, the pivotal connections of the arms 76 with the blocks 75 and 77 being such that the gages 73 can be moved vertically and horizontally. Friction joints are provided between the gages 73 and the block 75 and between the arm 76 and the blocks 75 and 77 so that the gages are retained in the position to which they are adjusted. A satisfactory form of friction joint is illustrated in Figs. 11 and 12 between the gages 73 and the block 75, this joint consisting of rings 78 which engage arc shaped slots in the upper and lower surfaces of the arm 73, and which are held clamped in position by means of a clamping bolt 79 passing through the slotted portion of the block 75 which receives the rear ends of the gages.

As has been stated, the movable gripping jaw is moved away from the stationary gripping jaw by means of a stop bar with which the downwardly projecting portion of the lever 53 comes in contact. This bar is indicated at 80 and extends across the front of the machine in a position to engage the lever 53 associated with each lower form as the form reaches its position of presentation at the front of the machine between the two upper forms. The position which the movable gripping jaw assumes when the form with which it is associated is in its position of presentation is indicated in Fig. 10. While the jaw is in this position the molded sole is removed and a flat sole is placed in position on the form, the position of the sole being accurately determined by the heel and side gages. It is necessary that the sole be held in this position during the movement of the form to a position in line with its cooperating

form and during the action of the forms thereon. To avoid any liability of the sole being displaced it is desirable that the movable gripping jaw be allowed to move into engagement with the sole while the form upon which the sole has been placed remains stationary. To this end the machine represented in the drawings is provided with means under the control of the operator for depressing the stop bar 80 so as to move it out of engagement with the lever 53 and allow the movable gripping jaw to move toward the stationary jaw. As illustrated in the drawings and particularly in Figs. 3, 8 and 10, the rod 80 is mounted upon arms 81 pivoted at 82 to the reciprocating cross-head 3, and the rear ends of the arms 81 are extended downwardly and are acted upon by coil springs 83 which hold the stop bar 80 yieldingly in its raised position. The upward movement of the bar under the force of the springs is limited by stop pins 84 engaging the downwardly extending rear ends of the arms 81. A block 85 is pivoted at 86 upon the frame of the machine and is provided with upper and lower slotted arms through which a vertical rod 87 projects. Above the block 85 the rod 87 is provided with an off set or projection 88 which when the rod is depressed is adapted to engage the upper arm of the block 85 and swing the block downwardly about its pivot. The upper arm of the block 85 extends over a projection 89 on one of the arms 81, and as the block 85 is swung downwardly, the upper arm of the block engages this projection and depresses the arm 81 and the stop bar 80 mounted thereon. The slots in the upper and lower arms of the block 85 are elongated and the rod 88 is pressed outwardly in the slots by means of a spring pressed pin 90 mounted in the block. During the downward swinging movement of the block 88 the lower arm of the block engages the rod 87 and moves the rod in a direction to remove the projection 88 from engagement with the upper arm of the block. The projection 88 on the rod 87 disengages the upper arm of the block 85 after the stop bar 80 has been depressed a sufficient distance to release the movable gripping jaw. As soon as the projection 88 is moved out of engagement with the upper arm of the block 85, the springs 83 raise the stop bar 80 to its original position or until the stop bar contacts with the lower end of the lever 53 of the movable gripper, and the projection 89 on one of the arms 81 engages the block 85 and returns the block to its original position. The rod 87 is connected at its lower end to a foot treadle 91 by means of which the rod may be depressed by the operator and it will be noted that by reason of the construction above described the return of the stop bar 80 to its normal

position will not be prevented even if the treadle 91 is kept depressed by the operator.

The invention having been thus described, 5 what is claimed is:

1. A sole pressing machine, having, in combination, male and female sole molding forms, a carrier removably secured to one of said forms, a gage for the heel end of the sole mounted on said carrier, and a gripping device also mounted on said carrier adapted to grasp a sole and hold it in position during the operation of the forms thereon.

2. A sole pressing machine, having, in 15 combination, male and female sole molding forms, and a sole gripping device consisting of two gripping jaws separate from the forms and arranged to engage opposite surfaces of the sole at the heel end thereof and 20 hold the sole in position during the operation of the forms thereon.

3. A sole pressing machine, having, in combination, male and female sole molding forms, a sole gripping device consisting of a stationary and a movable jaw arranged to 25 engage opposite surfaces of a sole at the heel portion thereof, and means for adjusting the stationary jaw toward and from the movable jaw.

4. A sole pressing machine, having, in 30 combination, male and female sole molding forms, a sole gripping device, a carrier therefor, means for actuating the gripping device to grasp and release a sole, and means 35 controlled by the operator for permitting the gripping device to grasp the sole while the carrier is stationary.

5. A sole pressing machine, having, in 40 combination, male and female sole molding forms, sole gripping jaws, a carrier therefor, means acting automatically to open said jaws to release a sole, and means controlled by the operator for closing said jaws to grasp a sole while the carrier is stationary.

45 6. A sole pressing machine, having, in combination, male and female sole molding forms, sole gripping jaws, means for actuating said jaws to grasp a sole and hold it in position during the action of the forms 50 thereon, a stop acting to open the jaws to release the sole, and means controlled by the operator for actuating the stop to allow the jaws to grasp a sole.

7. A sole pressing machine, having, in 55 combination, upper and lower sole molding forms, means for actuating said forms to produce pressure and clearance and for moving the lower form to a position of presentation out of alinement with the upper form, sole gripping jaws mounted on the lower 60 form, a stop arranged to actuate the jaws to release a sole when the lower form reaches its position of presentation, and means controlled by the operator for actuating the 65 stop to allow the jaws to grasp the sole while

the lower form is in its position of presentation.

8. A sole pressing machine, having, in combination, male and female sole molding forms, a carrier removably secured to one of said forms, cooperating sole gripping jaws 70 mounted on said carrier, and means for actuating said jaws to grasp a sole and hold it in position during the operation of the forms thereon.

9. A sole pressing machine, having, in combination, male and female sole molding forms, a carrier removably secured in fixed position with relation to one of said forms, a gage for the heel end of the sole mounted 80 on said carrier, and a gripping device also mounted on said carrier consisting of relatively movable jaws arranged to engage opposite surfaces of a sole at the heel portion thereof.

10. A sole pressing machine, having, in combination, male and female sole molding forms and a side gage associated with one of said forms arranged to engage the side 90 edge of a sole, and having provision for vertical, lateral and longitudinal adjustment with relation to the form.

11. A sole pressing machine, having, in combination, male and female sole molding forms, a carrier removably secured to one of said forms, a sole gripping device and an adjustable gage for the heel end of the sole mounted on said carrier, means for actuating said gripping device to grasp a sole and hold it in position during the operation of 100 the forms thereon, an index plate and pointer for indicating the positions of the heel gage and means for relatively adjusting the index plate and pointer.

12. A sole pressing machine, having, in 105 combination, male and female sole molding forms, means for actuating said forms to produce pressure and clearance, a gage for the heel end of the sole, a gage for the side of the sole associated with one of said forms, and means for relatively actuating the form and side gage to separate the side gage and shoe sole before the forms are brought into a position of pressure.

13. A sole pressing machine, having, in 115 combination, upper and lower sole molding forms, means for actuating said forms to produce pressure and clearance and for moving the lower form to a position of presentation out of alinement with the upper form, and a gage for the side of the sole arranged to engage the sole when the lower form is in a position of presentation, and to be out of engagement with the sole when the form is in a position of pressure. 125

14. A sole pressing machine, having, in combination, upper and lower sole molding forms, means for actuating said forms to produce pressure and clearance and for moving the lower form to a position of pres- 130

entation out of alinement with the upper
form, a gage for the heel end of the sole
mounted to move with the lower form, and
a stationary gage for the side of the sole
5 arranged to engage the sole when the lower
form is in a position of presentation.

15. A sole pressing machine, having, in
combination, upper and lower sole molding
forms, means for actuating said forms to
10 produce pressure and clearance and for
moving the lower form to a position of pres-
entation out of alinement with the upper

form, a carrier mounted in fixed position
with relation to the lower form, a gage for
the heel end of the sole mounted on said 15
carrier, and a gripping device for the heel
end of the sole also mounted on said carrier.

In testimony whereof I affix my signature,
in presence of two witnesses.

BENJAMIN F. MAYO.

Witnesses:

FRED O. FISH,
FARNUM F. DORSEY.

Copies of this patent may be obtained for five cents each, by addressing the "Commissioner of Patents,
Washington, D. C."
