

J. C. Stover, Cultivator.

No. 108945.

Patented. Nov. 1. 1870.

Fig. 1

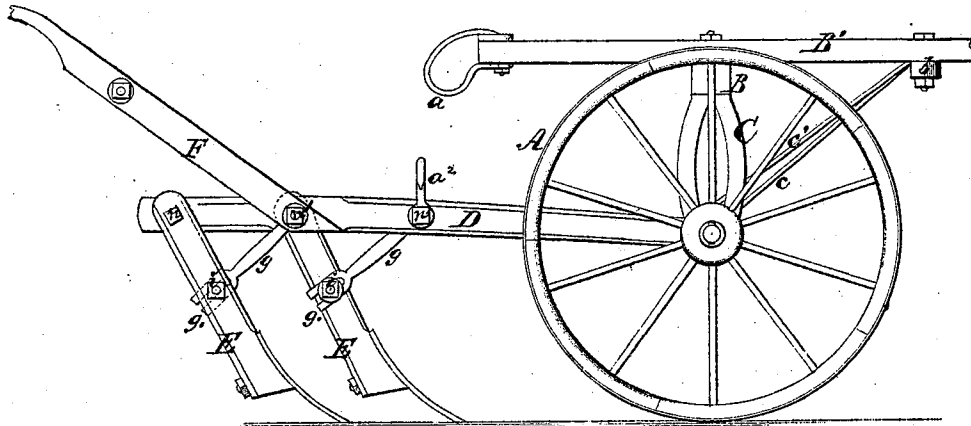
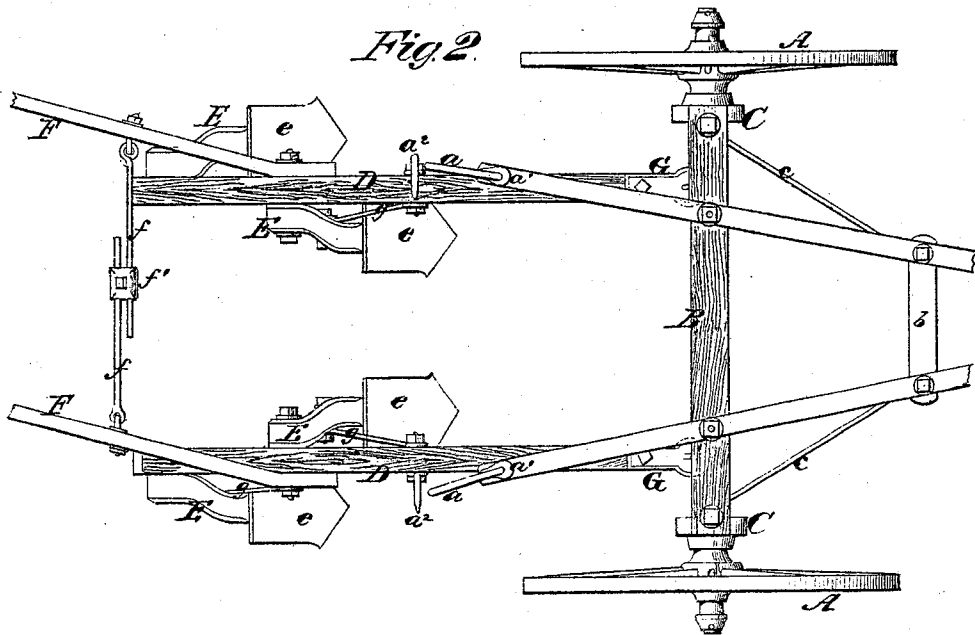

Fig. 2



Witnesses
W. Washburn
J. C. Campbell

Inventor
J. C. Stover
by
Mason, Smith & Lamson

D. C. Stover, Cultivator.

No. 108945.

Patented Nov. 1. 1870.

Fig. 3

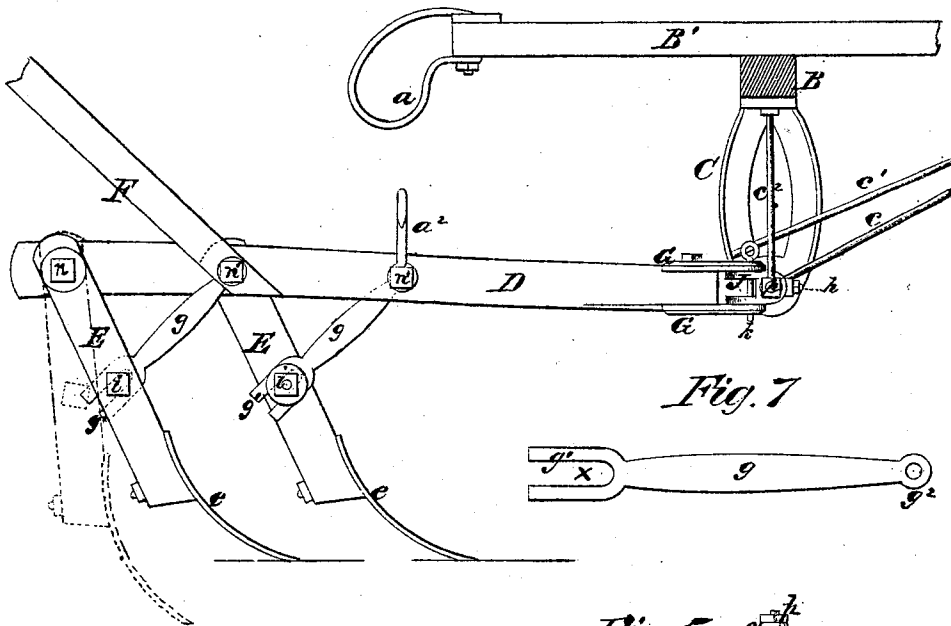

Fig. 7

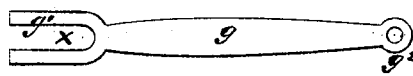

Fig. 4

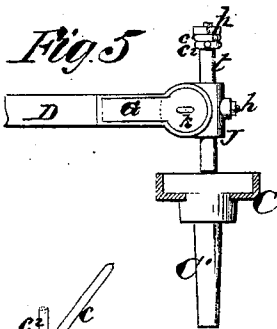
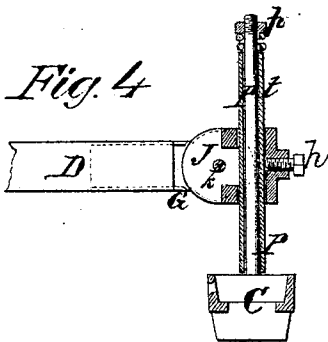
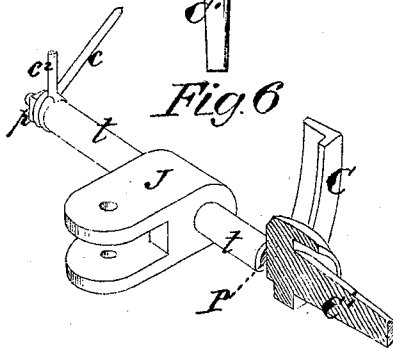

Fig. 6



Witnesses.

W. H. Campbell
J. N. Crumpler

Inventor.

D. C. Stover
by
Mason Lewis Williams

United States Patent Office.

DANIEL C. STOVER, OF LANARK, ILLINOIS.

Letters Patent No. 108,945, dated November 1, 1870.

IMPROVEMENT IN CULTIVATORS.

The Schedule referred to in these Letters Patent and making part of the same.

To all whom it may concern:

Be it known that I, DANIEL C. STOVER, of Lanark, in the county of Carroll and State of Illinois, have invented certain Improvements on Cultivators; and I do hereby declare that the following is a full, clear, and exact description thereof, reference being had to the accompanying drawing, making part of this specification, in which—

Figure 1, plate 1, is an elevation of one side of my improved cultivator.

Figure 2, plate 1, is a top view of the cultivator.

Figure 3, plate 2, is a section, in detail, of the improved devices.

Figures 4, 5, and 6, plate 2, are views, in detail, showing my mode of attaching the shovel-beams to the frame of the machine.

Figure 7, plate 2, is a view of my improved brace.

Similar letters of reference indicate corresponding parts in the several figures.

This invention relates to improvements on cultivators which have their shovel-beams attached to carriages.

The nature of my invention consists:

First, in a forked brace for connecting a shovel-standard to the beam in such manner as to allow the adjustment of the said standard to any desired angle with respect to the beam, and also to allow the detachment of the standard from such brace should the shovel meet with an obstruction in its path, which would be liable to break or derange the machine, as will be hereinafter explained.

Second, in applying the adjustable eye-bearing, which connects the shovel-beam to the carriage, to a long tube or sleeve which is upon an inner cylindrical extension of the limb of the carriage, whereby a long tubular bearing is obtained for said eye-bearing, upon which the latter can be adjusted laterally, for setting the shovel-beams at different distances apart, as will be hereinafter explained.

To enable others skilled in the art to understand my invention I will describe its construction and operation.

In the accompanying drawing, figs. 1 and 2, I have represented my improvement applied to a two-wheel carriage.

This carriage consists of two wheels, A A, applied on axles C', which extend outwardly from two uprights, C C, on the upper ends of which is secured an axle-tree or horizontal cross-bar, B.

On this bar is secured a bifurcated draft-pole, B', carrying loops *a a* on its rear extended ends, and having the axle-uprights C C secured to it by brace-rods *e e* *e'*, as shown, or in any other suitable manner.

Such a carriage is especially adapted for use in cultivators for tall crops, as the cross-bar B is elevated

sufficiently to clear the rows of plants under cultivation and allow the wheels and horses to travel in the furrows between the rows.

In order to attach the shovel-carrying beams D to a frame with an elevated cross-bar B, as above described, rod-extensions P P are applied to the inner ends of the short axles C C, on which rods tubes *t* are loosely applied, and kept in place by nuts *p*, screwed on the inner ends of said rods.

These tubular bearings *t* should be of such length respectively, as will allow the required lateral adjustment of the shovel-carrying beams.

On each tubular bearing *t*, an eye-bearing, J, is placed, and secured to it firmly by means of the set-screw *h*, or by any other device which will admit the said bearing J to be loosened from its bearing *t*, for adjustment.

The eye-bearing J receives on its top and bottom the plates G G, which are connected to the said bearing by a vertical pivot, *k*.

The plates G G are secured permanently to the front end of the shovel-carrying beam D.

By means of the eye-bearing J and its tube *t* rocking on the horizontal rod P, and the vertical pivotal connection *k* of the beam D to the said eye-bearing J, it will be seen that the beam D is allowed to receive universal movement.

The tube *t* is prevented from receiving endwise movement on the rod P by the end abutments shown in figs. 4 and 5, but this tube is allowed to oscillate freely on said rod P, and thereby it will afford a long support for the eye-bearing J, which is secured to it.

The eye-bearing can be adjusted on its tube either toward the right or left hand by loosening the clamp-screw *h*.

The shovel-carrying beams, their handles or stilts F, and the standards E, and shovels *e*, may all be constructed in the usual well-known manner. The hooks *a'* on the beams D are used for suspending these beams and their attachments from the loops *a* on the rear ends of the draft-pole, and the cross-rods *f f*, and block *f'* are used to connect the rear ends of the beams D D together.

Each one of the shovel-standards E is connected at its upper end to a beam, D, by means of a single transverse bolt, which will allow the standard to swing longitudinally as though it was pivoted.

Below the said pivot-bolt the standard is connected by a transverse bolt, *i*, to the inclined brace *g*, which extends forward and upward and is connected to beam D by a transverse pivot-bolt, *n*.

Each brace *g* has an eye, *g'*, formed on one end and a fork, *g''*, formed on its opposite end; and by means of a washer and the bolt and nut *i*, the fork-

end is secured to the standard, so as to resist any ordinary backward thrust against the shovel; but should the shovel meet with an obstacle in its path which would be liable to derange or break the machine, the attachment will give way and the bolt *i* will slip out of the slot *x* and allow the shovel to fall back.

The slot *x* is also made of such length as will allow the standard to be adjusted and set at different angles with respect to the beam *D*:

I am well aware that closed slotted braces, wooden pins with eye-braces, and other like devices have been employed in combination with drill-teeth, cultivator-standards, and plow-standards, and I do not claim as my invention such devices.

I have constructed a brace, *g*, with an eye, *g*², on one end and an open slot or fork on the opposite end, which open slotted end will allow an adjustment of the cultivator-beam, so that it can be set to work at different angles, and also allow the beam to become

detached from the brace when subjected to extraordinary strain.

Having thus described my invention,

What I claim as new, and desire to secure by Letters Patent, is—

1. The combination of the short sliding eye-bearing *J*, long tubular bearing *t*, and retaining-screw *h*, substantially as described.

2. The short axle-extensions *P*, tubes *t*, braces *c* *c*¹ *c*², and forked tongue, combined substantially as and for the purpose described.

3. The tubular eye-bearing *J*, with perforated ears, in combination with the short axle-extensions *P*, tube *t*, plates *G G*, and beam *D*, substantially as described.

DANIEL C. STOVER.

Witnesses:

R. P. WALES,
D. D. WILEY.