

L. STEVENS.
 Making Illuminating Gas.

No. 76,841.

Patented April 14, 1868.

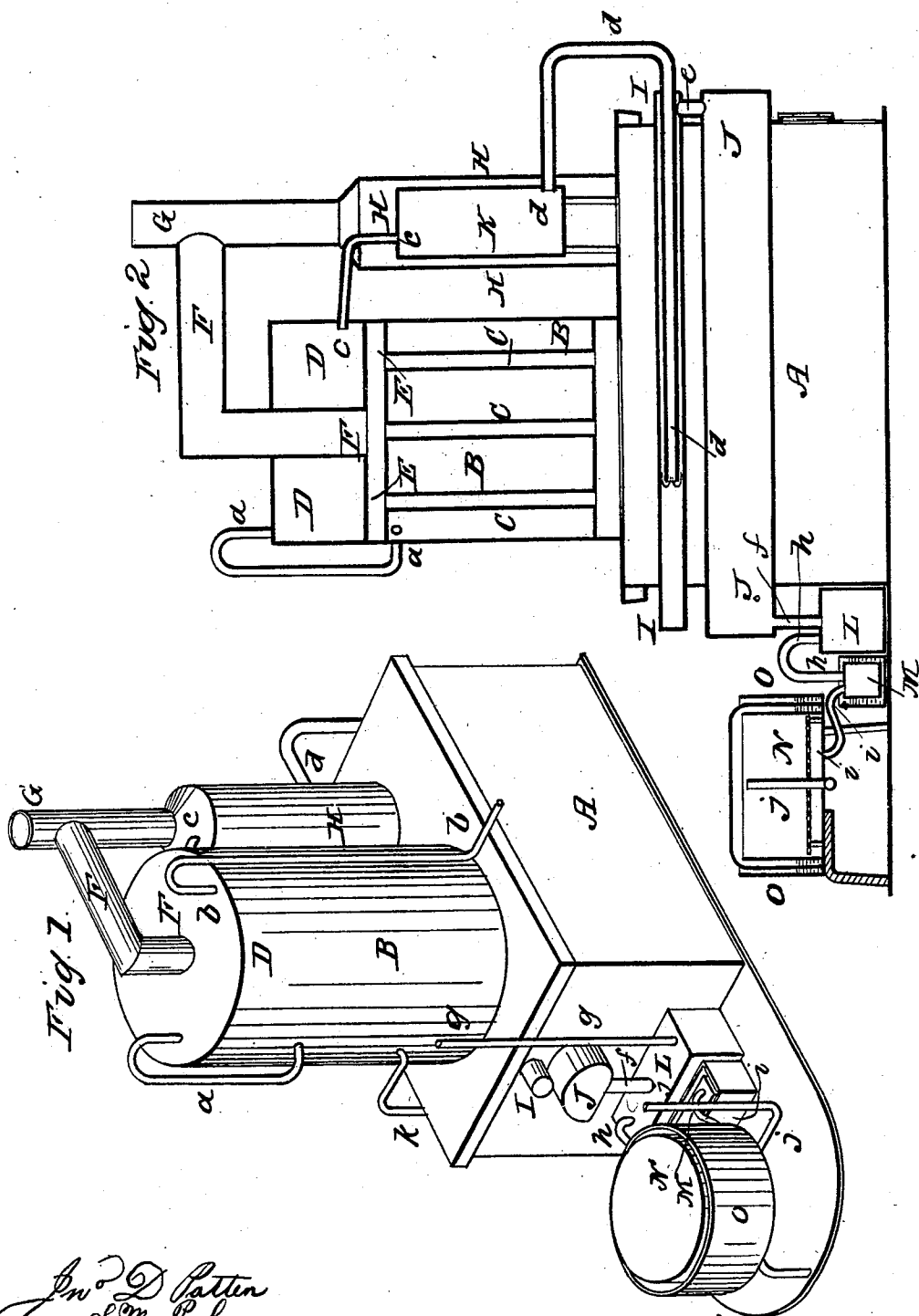

*John D. Patten
 S.M. Pool*

*Levi Stevens
 By atty AB Staughton*

UNITED STATES PATENT OFFICE.

LEVI STEVENS, OF WASHINGTON CITY, DISTRICT OF COLUMBIA.

IMPROVED APPARATUS FOR MANUFACTURING ILLUMINATING-GAS.

Specification forming part of Letters Patent No. 76,841, dated April 14, 1863.

To all whom it may concern:

Be it known that I, LEVI STEVENS, of the city of Washington, in the District of Columbia, have invented certain new and useful Improvements in Apparatus for Manufacturing Illuminating-Gas; and I do hereby declare the following to be a full, clear, and exact description of the same, reference being had to the accompanying drawings, making a part of this specification, in which—

Figure 1 represents a perspective view of the apparatus. Fig. 2 represents a vertical longitudinal and central section through the same.

Similar letters of reference, where they occur in the separate figures, denote like parts of the apparatus in both of the drawings.

My invention relates to an apparatus where-in illuminating-gas is made, composed of the vapors or heated products of a hydrocarbon and of a hydro-oxygen, mixed, converted into a fixed gas, cooled, and purified, and ready to be burned.

To enable others skilled in the art to make and use my invention, I will proceed to describe the same with reference to the drawings.

Over a suitable furnace, A, is arranged a boiler, B, having flue-pipes C passing up through it, and in which steam is generated. Over this boiler B there is a mixing-chamber, D, into which the steam from the boiler enters through a pipe, *a*. Into this chamber D is also forced, through a pipe, *b*, and by any suitable and well-known forcing contrivance, a hydrocarbon, crude or in a vaporous condition, so that it will mix with the steam in said chamber. The flue-space E, between the boiler and the mixing-chamber, in which the flue-pipes C terminate, serves to dry or superheat the mixed steam and hydrocarbon in the chamber D, as it brings the fire or burning products in direct contact with the bottom of said chamber. The flue-pipe F passes up through the center of the mixing-chamber, and thence passes to the exit pipe or flue G of the furnace, said flue-pipe F also serving to dry or superheat the vapors in the chamber D. When the hydrocarbon and the hydro-oxygen have become mixed, dried, and heated in the chamber D they pass, through a pipe, *c*, into

a superheater, K, inclosed in a jacket, H, which is in more immediate contact with the fire in the furnace, and subject to a more intense heat than the chamber D. In this superheater the mixed vapors are thoroughly dried or superheated, and thence pass out and through a pipe, *d*, which leads into and nearly through a small retort, I, set in the bench or furnace, where it becomes, if not entirely, very nearly, a fixed gas, and this gas, passing out of the end of the tube or pipe *d*, returns back between the tube and the retort I, and thence, through a pipe, *e*, into the main or large retort J, where it is converted into a positively-fixed gas. From the retort J the gas passes, through a pipe, *f*, into a mixer, L, where atmospheric air may be mixed with the retorted gas, the air being introduced into the mixing-chamber L through a pipe, *g*. From the mixer the gas passes, through a pipe, *h*, into a cooler, M, surrounded by water, and from the cooler it passes, through a pipe, *i*, into the purifier N, also surrounded by or sitting in a water-tank, O, and from the purifier the gas may go to the gasometer, the main, or to the burner, through a pipe, *j*. In the purifier I use chloride of calcium as the purifying material.

A draw-off pipe, *k*, may be used for drawing off the boiler, when necessary to do so.

If the mixed and superheated vapors of the hydrocarbon and of the hydro-oxygen be drawn off from the pipe *d* before they enter the retort and are condensed, it will be found that the effect upon the hydrocarbon is the same as though distilled and purified. It is, in effect, a distilling operation, and needs only to be drawn off from the pipe *d*, and carried to any condensing apparatus, to accomplish perfect distillation.

It should be observed of the pipes *f* and *g*, leading into the mixer L, that their ends in the mixer should be "trapped" in any well-known way.

Having thus fully described my invention, what I claim is—

1. In combination with the mixing-chamber D, the superheater E, so that the mixed hydrocarbon and hydro-oxygen vapors may be superheated before being retorted, substantially as and for the purpose described.

2. I claim also, in combination with the

mixing and superheating chambers, the arrangement of retorts for retorting the vapors, substantially as described.

3. I claim also the mixing chamber or vessel L, into which the retorted gas is passed, and into which atmospheric air is forced and therein mixed with the gas, substantially as described.

4. I also claim, in combination with the mixing-chamber L, the cooler M, so that the cooling shall take place after the atmospheric

air is introduced and mixed with the gas, substantially as described.

5. I also claim, in combination with the cooler M, the purifying-chamber N, furnished with chloride of calcium as a purifier, substantially as described.

LEVI STEVENS.

Witnesses:

A. B. STOUGHTON,
JOHN S. HALL.