



- (51) International Patent Classification:
F28G 9/00 (2006.01)
- (21) International Application Number:
PCT/IB2016/056709
- (22) International Filing Date:
8 November 2016 (08.11.2016)
- (25) Filing Language: English
- (26) Publication Language: English
- (30) Priority Data:
1519844.3 10 November 2015 (10.11.2015) GB
- (71) Applicant: I.D.E. TECHNOLOGIES LTD. [IL/IL];
Hamatechet Street, Hasharon Industrial Park, P.O.B. 5016,
60920 Kadima (IL).
- (72) Inventor: EFRAT, Tomer; C/o I.D.E. Technologies Ltd.,
Hamatechet Street, Hasharon Industrial Park, P.O.B. 5016,
60920 Kadima (IL).
- (74) Agent: FISHER, Zeev; FRESH IP, 32b Habarzel Street,
Ramat Hachayal, 69710 Tel Aviv (IL).
- (81) Designated States (unless otherwise indicated, for every
kind of national protection available): AE, AG, AL, AM,

AO, AT, AU, AZ, BA, BB, BG, BH, BN, BR, BW, BY, BZ, CA, CH, CL, CN, CO, CR, CU, CZ, DE, DJ, DK, DM, DO, DZ, EC, EE, EG, ES, FI, GB, GD, GE, GH, GM, GT, HN, HR, HU, ID, IL, IN, IR, IS, JP, KE, KG, KN, KP, KR, KW, KZ, LA, LC, LK, LR, LS, LU, LY, MA, MD, ME, MG, MK, MN, MW, MX, MY, MZ, NA, NG, NI, NO, NZ, OM, PA, PE, PG, PH, PL, PT, QA, RO, RS, RU, RW, SA, SC, SD, SE, SG, SK, SL, SM, ST, SV, SY, TH, TJ, TM, TN, TR, TT, TZ, UA, UG, US, UZ, VC, VN, ZA, ZM, ZW.

- (84) Designated States (unless otherwise indicated, for every kind of regional protection available): ARIPO (BW, GH, GM, KE, LR, LS, MW, MZ, NA, RW, SD, SL, ST, SZ, TZ, UG, ZM, ZW), Eurasian (AM, AZ, BY, KG, KZ, RU, TJ, TM), European (AL, AT, BE, BG, CH, CY, CZ, DE, DK, EE, ES, FI, FR, GB, GR, HR, HU, IE, IS, IT, LT, LU, LV, MC, MK, MT, NL, NO, PL, PT, RO, RS, SE, SI, SK, SM, TR), OAPI (BF, BJ, CF, CG, CI, CM, GA, GN, GQ, GW, KM, ML, MR, NE, SN, TD, TG).

Published:

— with international search report (Art. 21(3))

(54) Title: CLEANING A MULTI-EFFECT EVAPORATOR

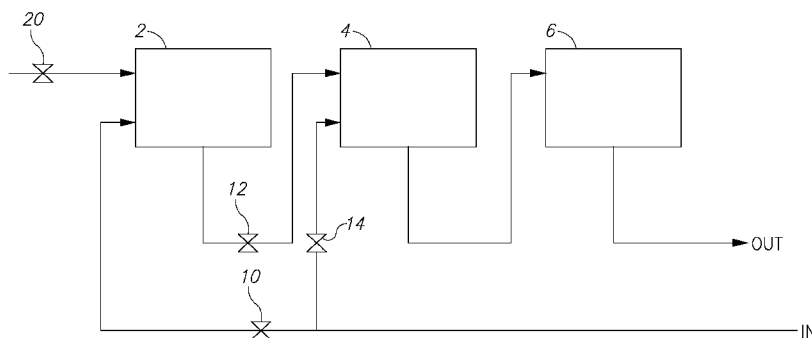

Figure 1

(57) Abstract: A method and system for cleaning a multistage evaporator, the evaporator having a normal operational mode and a cleaning mode and having at least two groups of effects (2, 4), each group having one or more effects. In a normal operational mode, input vapor is introduced to a first group of effects (2), the first group comprising the hottest effects, and then vapor is delivered from the first group to a second group of effects (4), and optionally, from the second group of effects to a third group of effects (6) and so on depending on the total number of effects. Upon detection of a predetermined level of scale formation in the first group of effects, the evaporator is switched to a cleaning mode wherein the first group of effects (2) is physically separated from the other groups of effects and the input vapor is re-directed into the second group of effects (4). A cleaning agent is introduced into the physically separated first group of effects (2) until a predetermined level of cleanliness is achieved.



CLEANING A MULTI-EFFECT EVAPORATOR

This invention relates to an improved method and system for cleaning a multi-effect evaporator.

TECHNICAL FIELD.

Multiple-effect evaporators use the heat from steam to evaporate water. Water is evaporated in a sequence of effects, each held at a lower pressure than the last. The evaporation temperature of water decreases as pressure decreases, so vapor evaporated in one vessel can be used to heat the next, and only the first vessel (at the highest pressure) requires an external source of heat. This is called multi-effect evaporation. Multiple-effect evaporators are widely used in all industrial applications where large volumes of water must be evaporated, such multi-effect distillation for the desalination of sea water.

Different types of evaporator exist such as multi-stage flash (MSF) evaporators and mechanical-vapour-compression evaporators (MVC) but all involve a series of stages with a cold end and a hot end with one or more intermediate stages between the two ends.

Multiple effect evaporation is frequently accompanied by the formation of scale on the feed side of one or more of the evaporator effects. This reduces the heat transfer coefficient and hence the capacity of the evaporator. Scale deposits can be difficult to remove and generally require shut down of the plant with a consequential loss of production so that chemicals or other means may be used to remove the deposits. This is clearly detrimental to the overall efficiency of the plant.

It is an object of the present invention is to provide an improved method for cleaning a multistage evaporator that aims to overcome, or at least alleviate, the abovementioned drawbacks.

It is a further object of the present invention to provide an improved multi-effect evaporator that aims to overcome, or at least alleviate, the abovementioned drawbacks.

SUMMARY OF THE INVENTION.

A first aspect of the present invention provides a method for cleaning a multistage evaporator while minimizing the related shutdown duration, the evaporator having a normal operational mode and a cleaning mode and having at least two groups of effects, each group having one or more effects, the method comprising:

introducing input vapor to a first group of effects, the first group comprising the hottest effects; and

delivering vapor from the first group to a second group of effects; and optionally, delivering vapor from the second group of effects to another group of effects and so on dependent upon the total number of groups of effects, during a normal operational mode;

the method further comprising:

a cleaning mode comprising physically separating the first group of effects from the second and optionally, other groups of effects, at periodic intervals;

re-directing the input vapor into the second group of effects during physical separation of the first group of effects; and

introducing a cleaning agent into the physically separated first group of effects until a predetermined level of cleanliness is achieved.

The method preferably further comprises physically re-joining the first group of effects to the second and optionally, other groups of effects, once the predetermined level of cleanliness has been achieved and re-directing the input vapor back to the first group of hottest effects to resume the normal operational mode.

It is preferable for the method to comprise physically sealing the first group of hottest effects from the second and optionally, other groups, to provide physical separation of the first group of effects.

The second group of effects generally comprises the group of effects nearest to the first group of hottest effects. It is to be appreciated that each group of effects may comprise a single effect or multiple effects. Thus, the method may involve three effects; a hot effect, an intermediate effect and a cold effect or multiple effects comprising a hot effect, multiple intermediate effects and a cold effect. Alternatively, multiple effects may be provided in each group of effects. Parallel feeding of each

effect, or group of effects, may be provided wherein fresh feed is delivered to each effect, or group of effects, and concentrated feed is withdrawn from each effect or group of effects. The vapour from each effect is still used to heat the next effect.

The method may further comprise closing at least one opening or aperture that allows fluid communication between a chamber housing the first group of effects and a chamber housing the second and optionally, other groups of effects, to physically separate the first group of effects from the second and optionally, other groups of effects. For example, a movable part may be provided to physically close the opening or aperture, for example in the form of a valve or tap.

Alternatively, the method may further comprise closing at least one shutter provided between the first group of effects and the second and optionally, other groups of effects, provided within a single chamber to physically separate the first group of effects from the second and optionally, other groups of effects, within the single chamber.

The method further comprises opening a valve, for example in the form of a tap, provided between the input line and the second group of effects to re-direct input vapor to the second group.

According to a second aspect of the present invention, there is provided a multi-effect evaporator having a normal operational mode and a cleaning mode, the evaporator comprising:

- a vapor compressor ;

- at least two groups of effects, each having one or more effects, the first group comprising the hottest group of effects;

- an input inlet for introducing vapor to the first group of effects;

- pipework for delivering vapor from the first group of effects to the second group of effects and, optionally, from the second group of effects to another group of effects and so on dependent upon the total number of groups of effects, during a normal operational mode;

- wherein the first group of effects is configured for its temporary physical separation from the second and optionally, other groups of effects, and the input inlet

is interchangeable to introduce vapor directly from the compressor to the second group of effects during the physical separation of the first group of effects from the second and optionally, other group of effects, to provide a cleaning mode.

The first groups of effects may be provided with a secondary inlet for the delivery of a cleaning agent to the first group of effects during the cleaning mode.

Preferably, a control unit is provided to switch the multi-effect evaporator from the normal operational mode to the cleaning mode when a predetermined level of scaling is detected in the first group of effects and/or to switch the multi-effect evaporator from the cleaning mode to the normal operational mode when a predetermined level of cleanliness is detected in the first group of effects.

In one embodiment, the hottest effect is placed in a first chamber and the second and optionally, other groups of effects, are provided in a second chamber, the chambers being connected by an opening that is sealable with a moveable part, such as a valve or tap, to allow temporary physical separation of the first group of effects.

Alternatively, the groups of effects may be provided in a single chamber provided with movable shutter (350) for sealing part of the chamber containing the first group of effects from the chamber containing the second and optionally, other groups of effects, to allow temporary physical separation of the first group of effects.

Preferably, the second group of effects is provided with at least two interchangeable vapor inlets, the first inlet directing vapor from the first group of effects to the second group of effects during normal operational mode of the evaporator and a second inlet directing vapor from the input inlet directly to the second group of effects during the cleaning mode of the evaporator.

It is to be appreciated that each group of effects may comprise a single effect or a plurality of effects. The groups of effects may have different numbers of effects.

BRIEF DESCRIPTION OF THE DRAWINGS.

Embodiments of the invention shall now be described, by way of example only, with reference to the accompanying drawings in which:

Figure 1A is a schematic diagram of a multi effect evaporator according to one embodiment of the present invention;

Figure 2 is a schematic diagram of a multi effect evaporator according to another embodiment of the present invention; and

Figures 3a and 3b are schematic diagrams of a multi effect evaporator according to yet another embodiment of the present invention, shown in a normal operational mode and a cleaning mode respectively.

DETAILED DESCRIPTION.

The present invention relates to an improved method of cleaning multi effect evaporator and to an evaporator having a normal operational mode and a cleaning mode.

Figure 1 of the accompanying drawings provides a schematic drawing of a multi-effect evaporator according to one embodiment of the present invention. The evaporator has an input stream for delivering hot feed water, such as sea water, to a first effect 2 (or group of effects). Water is evaporated in the effect and the vapour is delivered to the next effect (or group of effects) 4 which is held at a lower pressure than the last. The boiling temperature of water decreases as pressure decreases, so vapor evaporated in one vessel can be used to heat the next. Vapor produced in the second effect 4 then passes to a third effect (or group of effects) 6 before the final product is removed from the system.

It is to be appreciated that three effects, or group of effects, are shown in the accompanying figures but the evaporator may include more effects, or groups of

effects or only two effects or groups of effects, i.e. a hot and a cold effect or group of effects.

The first group of effects (or single effect) is subjected to the hottest temperatures and thus scale formation is greatest in this group/effect. Therefore, the present invention provides the evaporator with a cleaning mode wherein the first effect or group of effects are physically separated from the other groups of effects at periodic intervals. This is achieved by shutting of the taps 10, 12 and opening of tap 14 so that the input stream is redirected into the second effect or group of effects 4 with the first effect, or group of effects, being isolated from the rest of the evaporator. A cleaning agent is then introduced into the physically separated first group of effects (2) by opening a tap 20 in a cleaning agent fluid line until a predetermined level of cleanliness is achieved.

Once a predetermined level of cleanliness has been achieved in the first effect (or first group of effects) the taps 20 and 14 are shut and taps 10 and 12 re-opened so that the input stream is re-directed back to the first group of hottest effects (2) to resume the normal operational mode.

Figure 2 illustrates one embodiment for providing the physical separation between the hottest effect, or group of effects 2, and the adjacent or second effect 4. The hottest effect 2 is provided in a separate chamber 200 and the second and further effects (or group of effects) are housed within another chamber 400. The chambers 200, 400 are connected by pipework that is sealable with a tap 12 to allow temporary physical separation of the first group of effects from the second and subsequent group of effects. In this manner, during normal operation, the taps 10 and 12 are open and tap 14 is shut so that the input stream passes feed into the first group of effects 2 and vapor passes from the first group along the pipeline to the second group of effects 4 and from the second group of effects to the third groups of effects 6. In the cleaning mode, taps 10 and 12 are shut and tap 14 opened thereby redirecting the input stream directly into the second group of effects 4 housed in the second chamber 400. Bypassing of the chamber 200 enables the first group of effects, which will experience the worst scaling, to be cleaned by introducing cleaning agent by opening a separate cleaning fluid pipeline having tap 20.

The apparatus preferably includes a control unit (not shown) which monitors scale build-up in the first effect, or group of effects, to switch the multi-effect evaporator from the normal operational mode to the cleaning mode when a predetermined level of scaling is reached and/or to switch the multi-effect evaporator from the cleaning mode to the normal operational mode when a predetermined level of cleanliness is detected in the first group of effects.

Figures 3a and 3b illustrate another embodiment of the present invention wherein the at least three effects, or groups of effects, are provided in a single chamber 300 which has means, such as a slidable shutter, for sealing the first part of the chamber housing the first effect, or group of effects 2 from the second and third effect, or group of effects 4,6. Figure 3a shows the shutter in the open configuration and the evaporator is able to perform in the normal operational mode with feed being delivered to the first effect 2 before the second and then third effects. When a predetermined level of scaling is detected in the first effect (or group of effects), the evaporator is switched into cleaning mode causing the shutter to shut and seal off the part of the chamber 300 that contains the first effect (or group of effects) to allow temporary physical separation of the first group of effects from the other effects, as shown in Figure 3b. This part of the chamber can then be cleaned while the other part of the chamber, containing the other effects, or group of effects, continues to operate normally.

CLAIMS

1. A method for cleaning a multistage evaporator, the evaporator having a normal operational mode and a cleaning mode and having at least a first group of effects and a second group of effects, each group having one or more effects,

the first group of effects and the second group of effects being provided within a single chamber,

a shutter being provided within the chamber to physically separate the first group of effects from the second group of effects,

wherein in the operational mode,

input vapor is introduced to the first group of effects, the first group of effects comprising the hottest effects;

and vapor is delivered from the first group of effects to the second group of effects within the chamber;

the method of cleaning comprising:

in the cleaning mode, physically separating the first group of effects (2) from the second groups of effects by shutting the shutter;

re-directing the input vapor into the second group of effects during physical separation of the first group of effects; and

introducing a cleaning agent into the physically separated first group of effects.

2. A method as claimed in claim 1 further comprising physically re-joining the first group of effects to the second group of effects, once a predetermined level of cleanliness has been achieved, and re-directing the input vapor back to the first group of hottest effects to resume the normal operational mode.

3. A method as claimed in any one of claims 1 to 3 wherein the second group of effects comprises the group of effects nearest to the first group of hottest effects.

4. A method as claimed in any one of claims 1 to 3 wherein input vapour is supplied on an input line, the method further comprising opening a valve provided between the input line and the second group of effects to re-direct input vapor to the second group of effects.

5. A method according to any one of the preceding claims comprising at least one further group of effects, the normal operational mode and cleaning mode comprising delivering the vapor from the second group of effects to the third group of effects within the chamber.

6. A multi-effect evaporator having a normal operational mode and a cleaning mode, the evaporator comprising:

at least a first group of effects and a second group of effects, each having one or more effects, the first group comprising the hottest group of effects;

the first group of effects and the second group of effects being provided within a single chamber,

an input inlet for introducing vapor to the first group of effects

and wherein vapor is delivered from the first group of effects to the second group of effects within the chamber;

wherein in the operational mode,

input vapor is introduced by the input inlet to the first group of effects, the first group of effects comprising the hottest effects;

and vapor is delivered from the first group of effects to the second group of effects;

and wherein to provide a cleaning mode a shutter is provided within the chamber to physically separate the first group of effects from the second group of effects,

the input inlet is operable to introduce vapor to the second group of effects during the physical separation of the first group of effects from the second group of effects, and

the first group of effects is provided with a secondary inlet for the delivery of a cleaning agent to the first group of effects during the cleaning mode

7. A multi-effect evaporator as claimed in claim 6 wherein a control unit is provided to switch the multi-effect evaporator from the normal operational mode to the cleaning mode when a predetermined level of scaling is detected in the first group of effects and/or to switch the multi-effect evaporator from the cleaning mode to the normal operational mode when a predetermined level of cleanliness is detected in the first group of effects.
8. A multi-effect evaporator as claimed in claim 6 or claim 7 wherein the second group of effects (4) comprises the group of effects nearest to the first group of hottest effects (2).
9. A multi-effect evaporator as claimed in any one of claims 6 to claim 8 comprising an input line to supply input vapour to the input inlet, and a valve provided between the input line and the second group of effects to re-direct input vapor to the second group of effects.
10. A multi-effect evaporator as claimed in any one of claims 6 to claim 9 comprising at least one further group of effects, wherein vapor is delivered from the second group of effects to the third group of effects within the chamber.
11. A multi-effect evaporator as claimed in any one of claims 6 to claim 10, further comprising a vapor compressor to supply input vapor to the input inlet.
12. A multi-effect evaporator as claimed in claim 11 wherein the vapor compressor is a thermos-compressor, mechanical or other vapor compressor.

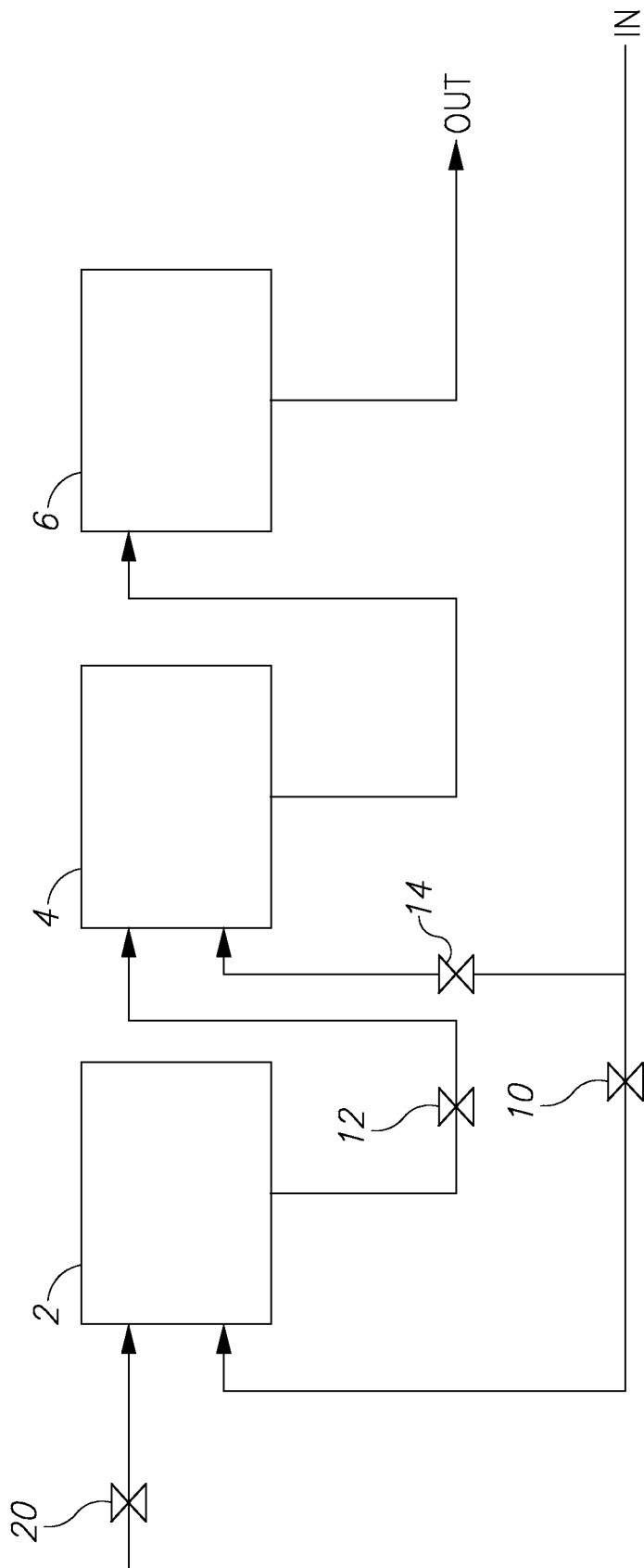

Figure 1

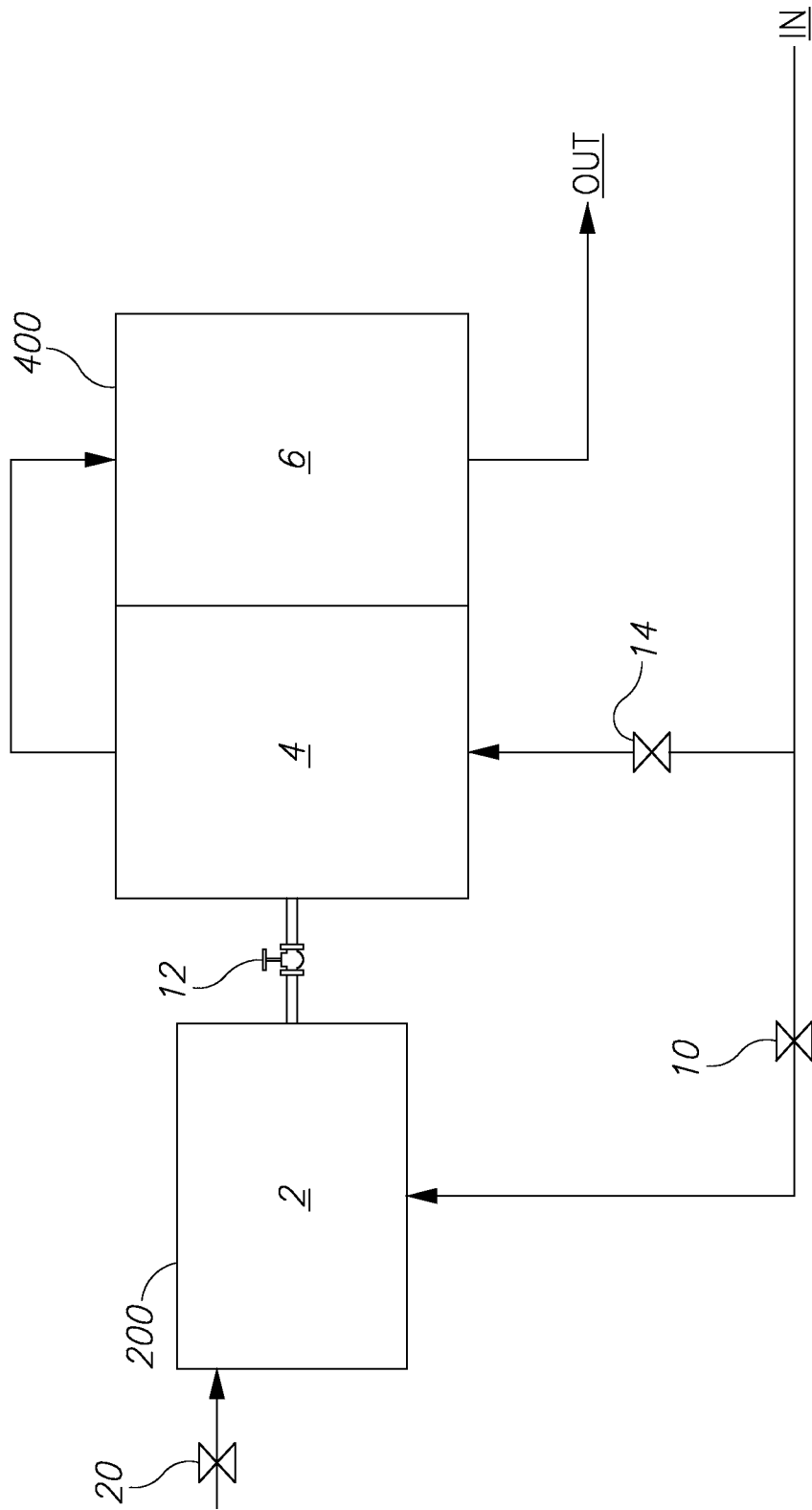

Figure 2

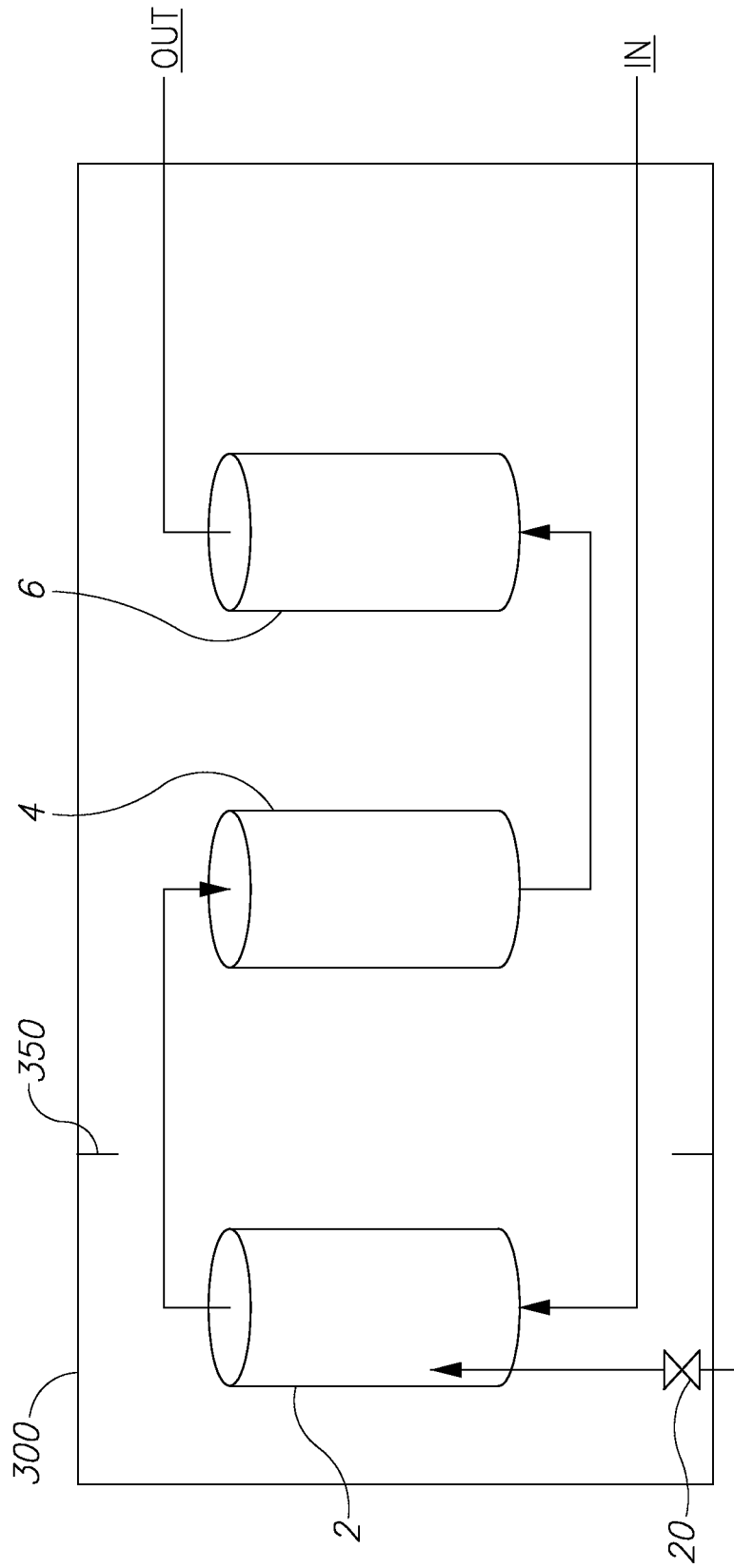

Figure 3A

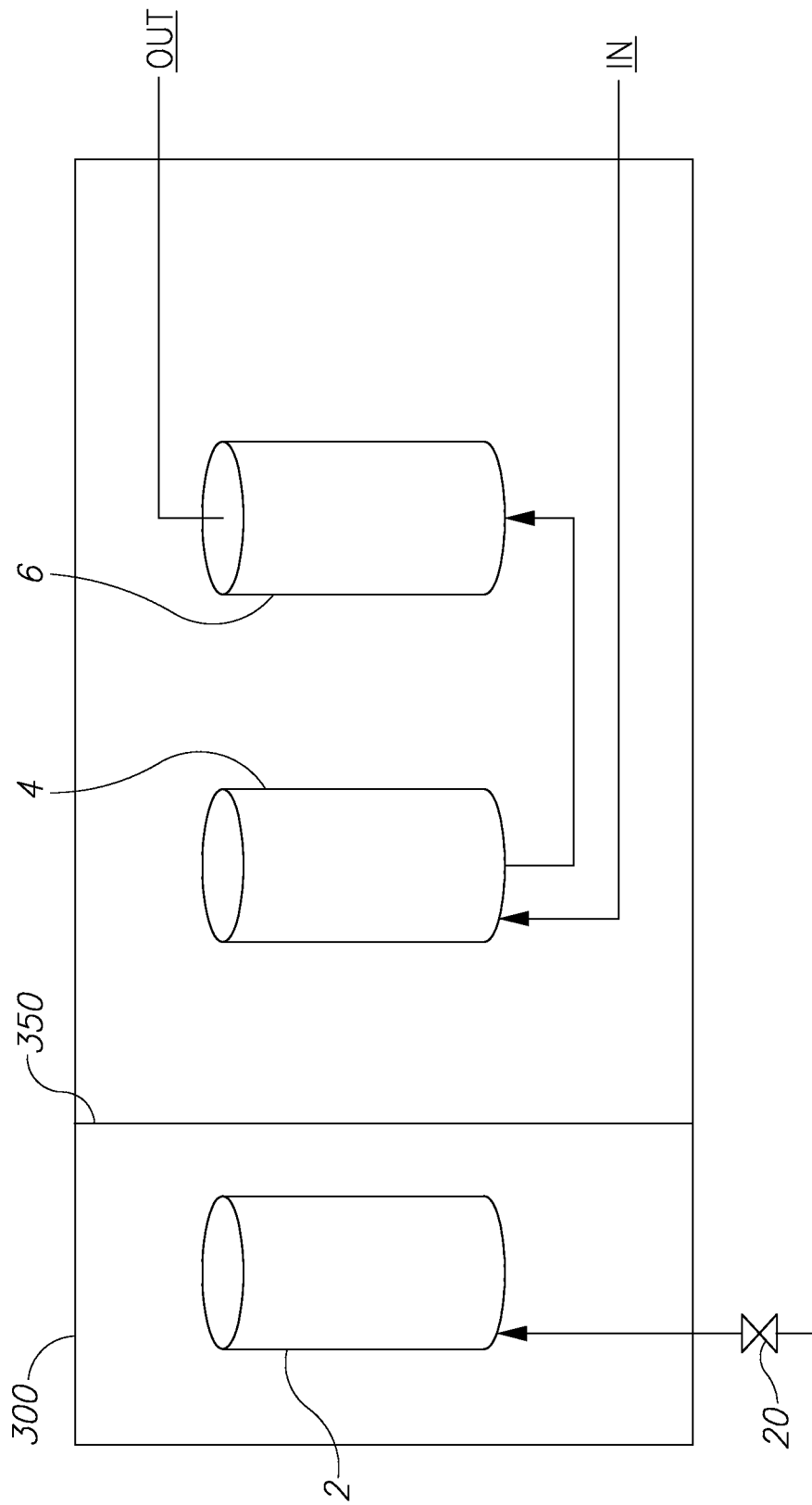

Figure 3B

INTERNATIONAL SEARCH REPORT

International application No
PCT/IB2016/056709

A. CLASSIFICATION OF SUBJECT MATTER
INV. F28G9/00
ADD.
According to International Patent Classification (IPC) or to both national classification and IPC

B. FIELDS SEARCHED
Minimum documentation searched (classification system followed by classification symbols)
F28G B08B B01D

Documentation searched other than minimum documentation to the extent that such documents are included in the fields searched

Electronic data base consulted during the international search (name of data base and, where practicable, search terms used)
EPO-Internal, WPI Data

C. DOCUMENTS CONSIDERED TO BE RELEVANT

Category*	Citation of document, with indication, where appropriate, of the relevant passages	Relevant to claim No.
X	US 5 964 982 A (ROLLER GUENTER [DE] ET AL) 12 October 1999 (1999-10-12) column 1, line 65 - column 3, line 9; figure 1	1-12
A	----- GB 1 497 429 A (METALLGESELLSCHAFT AG) 12 January 1978 (1978-01-12) the whole document	1-12
A	----- GB 1 011 603 A (AQUA CHEM INC) 1 December 1965 (1965-12-01) the whole document	1-12
A	----- WO 2011/032237 A1 (PHOENIX WATER [GB]; URWIN PETER M [AU]; O'CONNELL MICHAEL JOHN [AU]; W) 24 March 2011 (2011-03-24) the whole document	1-12
	----- -/--	

Further documents are listed in the continuation of Box C.

See patent family annex.

* Special categories of cited documents :

"A" document defining the general state of the art which is not considered to be of particular relevance

"E" earlier application or patent but published on or after the international filing date

"L" document which may throw doubts on priority claim(s) or which is cited to establish the publication date of another citation or other special reason (as specified)

"O" document referring to an oral disclosure, use, exhibition or other means

"P" document published prior to the international filing date but later than the priority date claimed

"T" later document published after the international filing date or priority date and not in conflict with the application but cited to understand the principle or theory underlying the invention

"X" document of particular relevance; the claimed invention cannot be considered novel or cannot be considered to involve an inventive step when the document is taken alone

"Y" document of particular relevance; the claimed invention cannot be considered to involve an inventive step when the document is combined with one or more other such documents, such combination being obvious to a person skilled in the art

"&" document member of the same patent family

Date of the actual completion of the international search 25 January 2017	Date of mailing of the international search report 02/02/2017
--	--

Name and mailing address of the ISA/ European Patent Office, P.B. 5818 Patentlaan 2 NL - 2280 HV Rijswijk Tel. (+31-70) 340-2040, Fax: (+31-70) 340-3016	Authorized officer Axters, Michael
--	---

INTERNATIONAL SEARCH REPORT

International application No
PCT/IB2016/056709

C(Continuation). DOCUMENTS CONSIDERED TO BE RELEVANT		
Category*	Citation of document, with indication, where appropriate, of the relevant passages	Relevant to claim No.
A	GB 2 443 802 A (L E T LEADING EDGE TECHNOLOGIE [GB]) 21 May 2008 (2008-05-21) the whole document -----	1-12

INTERNATIONAL SEARCH REPORT

Information on patent family members

International application No

PCT/IB2016/056709

Patent document cited in search report	Publication date	Patent family member(s)	Publication date
US 5964982	A	12-10-1999	AT 209062 T 15-12-2001
			DE 19629641 A1 29-01-1998
			DK 0820792 T3 21-05-2002
			EP 0820792 A2 28-01-1998
			ES 2168547 T3 16-06-2002
			US 5964982 A 12-10-1999

GB 1497429	A	12-01-1978	DE 2421410 A1 04-12-1975
			GB 1497429 A 12-01-1978

GB 1011603	A	01-12-1965	CH 428591 A 15-01-1967
			DE 1444322 A1 24-10-1968
			FI 43167 B 01-10-1970
			GB 1011603 A 01-12-1965
			NO 124790 B 05-06-1972
			US 3245460 A 12-04-1966

WO 2011032237	A1	24-03-2011	AU 2010295259 A1 19-04-2012
			CA 2774863 A1 24-03-2011
			CN 102630216 A 08-08-2012
			EA 201290143 A1 30-10-2012
			EP 2480501 A1 01-08-2012
			MA 33594 B1 01-09-2012
			US 2012241308 A1 27-09-2012
			WO 2011032237 A1 24-03-2011

GB 2443802	A	21-05-2008	NONE
