

(No Model.)

2 Sheets—Sheet 1.

M. D. LUEHRS.  
SCREW CUTTING MACHINE.

No. 521,172.

Patented June 12, 1894.

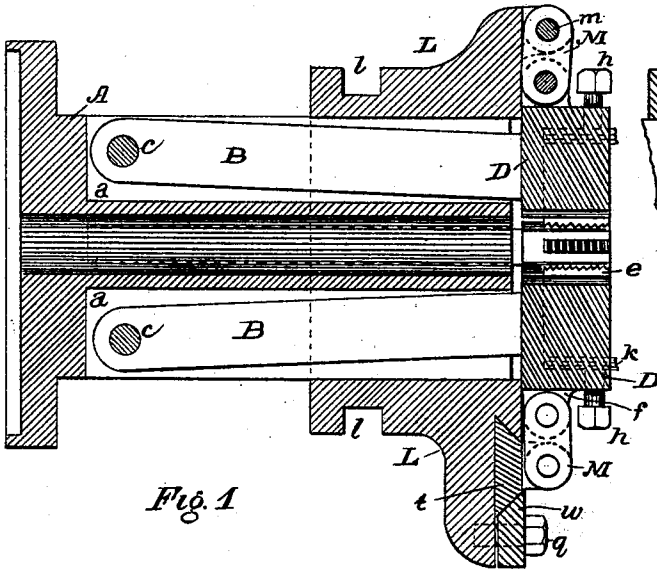

Fig. 1

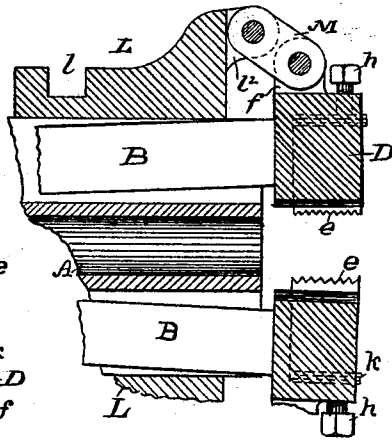

Fig. 2

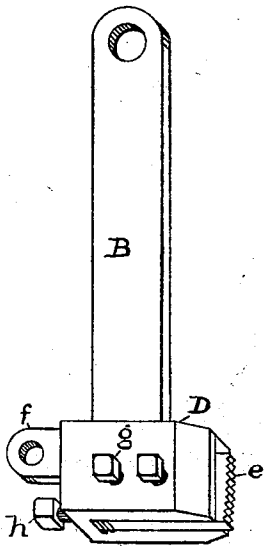

Fig. 4

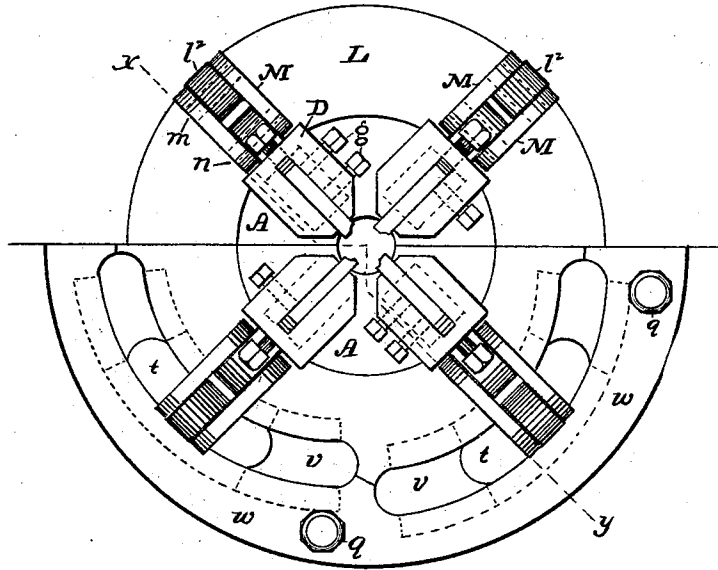

Fig. 3

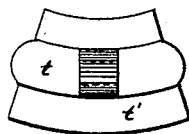

Fig. 5

Witnesses:

Myron B. Vorce  
Soren Knutson

Inventor:

Michel D. Luehrs,  
by M. Vorce  
Attorney.

(No Model.)

2 Sheets—Sheet 2.

M. D. LUEHRS.  
SCREW CUTTING MACHINE.

No. 521,172.

Patented June 12, 1894.

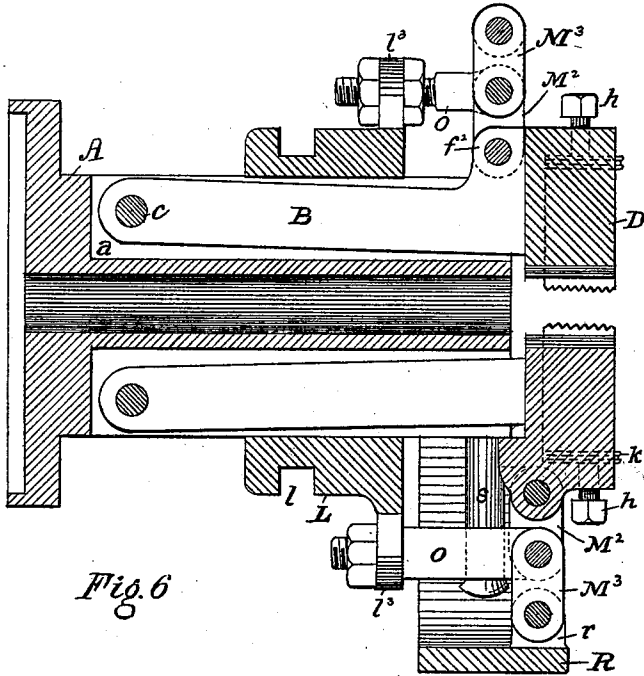

Fig. 6

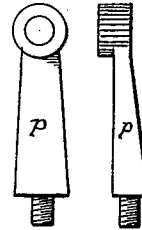

Fig. 8

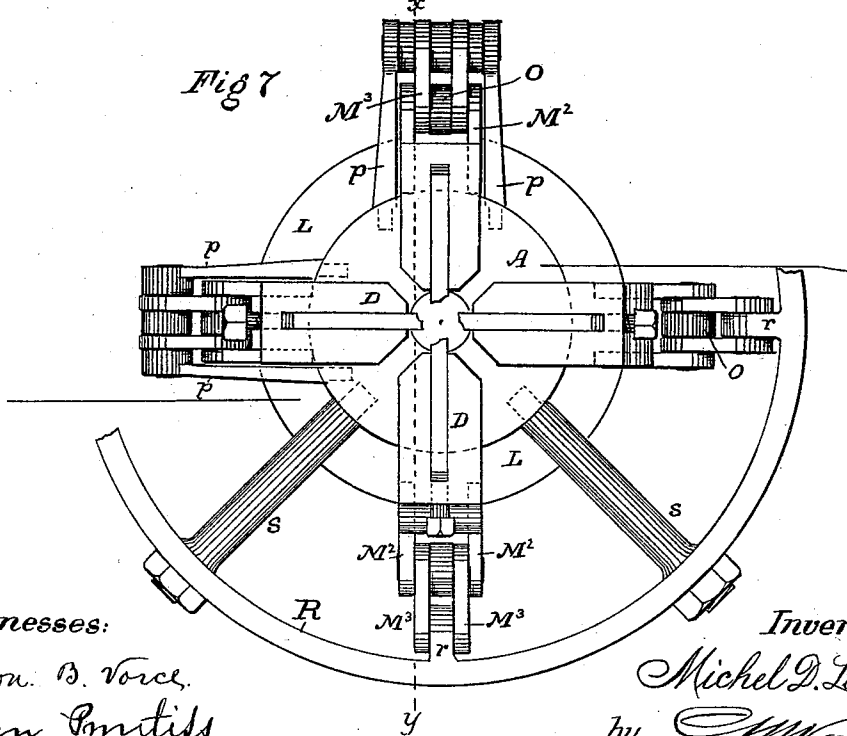

Fig. 7

Witnesses:  
Myron B. Vorce.  
Soren Ponsild

Inventor  
Michel D. Luehrs  
by *M. Vorce*  
Attorney

# UNITED STATES PATENT OFFICE.

MICHEL D. LUEHRS, OF CLEVELAND, OHIO.

## SCREW-CUTTING MACHINE.

SPECIFICATION forming part of Letters Patent No. 521,172, dated June 12, 1894.

Application filed October 27, 1893. Serial No. 439,251. (No model.)

*To all whom it may concern:*

Be it known that I, MICHEL D. LUEHRS, a citizen of the United States, residing at Cleveland, in the county of Cuyahoga and State of Ohio, have invented certain new and useful Improvements in Screw-Cutting Machines; and I do hereby declare the following to be a full, clear, and exact description of the invention, such as will enable others skilled in the art to which it appertains to make and use the same.

My invention relates to improvements in bolt-cutters, and has especial reference to the class wherein the dies are carried at the ends of pivoted arms.

The object of the invention is to secure greater ease of operation, increased efficiency, and diminished wear in use; and it consists in the novel features of construction, arrangement and combination hereinafter described and pointed out in the claims.

In the drawings Figure 1 represents in central vertical section a bolt-cutter head embodying my invention, the lower half of the figure exhibiting a modification of the structure shown in the upper half. Fig. 2 is a partial section in the same plane as Fig. 1, showing the parts in the open position, they being shown closed in Fig. 1. Fig. 3 is a front-end elevation of the structure shown in Fig. 1, the upper and lower halves of this figure showing the same parts respectively of Fig. 1. The broken line  $x-y$  in Fig. 2 indicates the plane of section of Figs. 1 and 2. Fig. 4 is a detached view of one of the die-carrying arms; Fig. 5 a plan view of one of the adjusting lugs or studs. Fig. 6 is a section in the same plane as Fig. 1, exhibiting, at the top and bottom respectively, two modified or alternative forms of the construction shown in Fig. 1. Fig. 7 is a front end elevation thereof. Fig. 8 is a detached view showing in elevation the front and side view of the studs  $p$ . The full line extending horizontally across Figs. 3 and 7 indicates the division line between the two structural forms shown in each figure.

In this class of bolt-cutters it has been usual to close the dies either by forming a cam-like incline on the pivoted arm on which the dies

are carried, and forcing a clutch-ring over such inclined face and upon a flat portion of the arm, on which flat portion the ring seats to lock the dies in the closed position; or by pivoting the die-carrying arms intermediate of their length and forcing apart the rear ends of the arms by a cam or toggle on or connected to the clutch-ring, to close the dies. In case a sliding cam-face is employed in either way the back-thrust of the dies causes great friction between the ring and the die-carrying arms, so that not only is great power required to close, but also to open the dies, and in both cases there is inevitably more or less spring to the arms between the pivotal points and the dies, which prevents accurate work being done. To obviate such friction and do away with all possibility of spring in the die-carrying arms are important ends had in view in the present invention, and I accomplish them by the use of a toggle outside of and directly over the die, as hereinafter described, which also reduces the amount of travel which the clutch-ring must have.

In the drawings A represents the "barrel" of a bolt-cutter head;  $a a$  are radial recesses therein, in which the die-carrying arms B B are seated, and are pivoted at their rear ends to the barrel by the pivots  $c$ . At their front ends the arms B are provided with die holders D, integral with or attached to the arms, in which holders are secured the dies  $e$ . A lug  $f$  on the holder or arm serves for the attachment thereto of the toggle. The dies are secured in their holders by one or more set screws  $g$ , and are fed down by means of screws  $h$ , with or without interposed strips of metal packing  $k$ , in a manner well known.

L is the clutch-ring, having the usual circumferential groove  $l$ , and provided opposite each of the holders D with a lug or stud by means of which it is connected by the toggle to the die-carrying arms or holders. It is obvious that the toggle connection of the clutch-ring to the die holders or arms can be effected by several alternative forms of construction, each producing the desired result; and in the drawings I have shown several modifications

of the form of the parts constituting the toggle connection, either of which may be adopted as preferred. In Fig. 2 and the upper half of Figs. 1 and 3, I have shown the simplest and most durable form, which I therefore consider the preferable one in most cases. In this form the clutch-ring L has forward projecting lugs  $l^2$ , to each of which is pivoted the outer end of a link or links M, the inner ends of which are pivoted to the lugs  $f$ , whereby the parts M D L form a single-acting toggle. It will be seen that when the parts are brought to the closed position shown in Fig. 1, the pivots of link M are brought in line with the back-thrust of the die, the outer pivot  $m$  being by preference slightly beyond, or farther forward than, the inner pivot  $n$ , as seen in Fig. 1, whereby a complete and perfect toggle lock is obtained, the inner end of link M resting against the face of the clutch-ring as shown. As the lug  $f$  is not long enough to allow the link M to become parallel with the axis of the barrel when the arms B are raised as far from the axis as the clutch-ring will permit, the toggle can never lock in the open position, and no back-stop for the clutch-ring is required.

In case a double-acting toggle is preferred to the single acting form, the construction shown in Fig. 6 may be adopted; the clutch-ring may have either the forward projecting lug  $l^2$ , shown in Fig. 1, or an outwardly projecting lug  $l^3$  to which is secured a link O, pivoted at its outer end to the center pivot of a double toggle composed of the links  $M^2$ , pivoted to lug  $f$ , and the links  $M^3$ , pivoted to studs  $p p$  attached to the barrel. In this form the links  $M^2$  are made to bear against the body of the holder D when the toggle is fully extended, and thus the toggle lock of the dies in closed position is effected. In addition the lug on holder D may be so extended as to rest upon the barrel when the dies are fully closed, as shown in lower part of Fig. 6. Should a stronger construction be required than is afforded by the studs  $p p$ , they may be dispensed with and in place thereof a strong ring R, having internal lugs  $r$  and secured to the barrel by standards  $s s$ , may be used, as shown in the lower part of Figs. 6 and 7, the other parts being unchanged.

As a greater range of adjustability is usually required than can be obtained by means of the screw  $h$  and packing  $k$ , I make the stud  $l^2$  radially adjustable in the ring L, and to do this I form the stud upon a plate  $t$  which slides in an eccentric groove or slot  $v$  in the face of the clutch-ring and is clamped to the ring, as by an outer loose ring  $w$  and clamping bolts or screws  $q$ , as shown in the lower half of Figs. 1 and 3. By loosening the clamp bolts and turning the ring L the studs to which the links M are pivoted may be set nearer to or farther from the axis of the barrel, and thus the same cutter-head may be set to cut bolts of different sizes.

What I claim as my invention, and desire to secure by Letters Patent, is—

1. In a bolt-cutter head the combination with the barrel, the die-carrying arms pivoted at their rear ends therein and having radial movement on such pivots, and a clutch-ring sliding on the barrel outside of the die-carrying arms, and not bearing on said arms, of a toggle connecting the clutch-ring with each die-carrying arm at its forward end, substantially as described.

2. In a bolt-cutter head the combination with the barrel, the die-carrying arms pivoted at their rear ends therein and having radial movement on such pivots, and a clutch-ring sliding on the barrel outside of the die-carrying arms, and not bearing on said arms, of a toggle connecting the clutch-ring with each die-carrying arm in line radially with the die, substantially as described.

3. In a bolt-cutter head the combination of the barrel, die-carrying arms pivoted at their rear ends therein and having radial movement on their pivots, a clutch-ring sliding on the barrel outside of the die-carrying arms, and not bearing on said arms, and a toggle link pivoted at one end to the clutch-ring and at the other to the forward end of the die-carrying arm, substantially as described.

4. In a bolt-cutter head the combination of a barrel, die-carrying arms pivoted at their rear ends therein and having radial movement on their pivots, a clutch-ring sliding on the barrel outside of the die-carrying arms, and not bearing on said arms, and a toggle link pivoted at one end to the clutch-ring and at the other to the die holder in line radially with the die, substantially as described.

5. In a bolt-cutter head the combination of a barrel, die-carrying arms pivoted therein at their rear ends and having radial movement on their pivots, a clutch-ring sliding on the barrel outside of the die-carrying arms, and a toggle link pivoted at one end to the forward end of the die-carrying arm and at the other to a forward extending stud on the clutch-ring, whereby the link is brought against the face of the clutch-ring when the dies are closed, and the dies are locked in the closed position, substantially as described.

6. In a bolt-cutter head the combination of a barrel, die-carrying arms pivoted at their rear ends therein and having radial movement on their pivots, a clutch-ring sliding on the barrel outside of the die-carrying arms, and a toggle connecting the forward end of the die-carrying arm with a forward extending stud adjustably secured to the clutch-ring, substantially as described.

7. In a bolt-cutter head the combination of a barrel, die-carrying arms pivoted therein, a clutch-ring sliding on the barrel, and a toggle link pivoted at one end to the die-carrying arm and at the other to a stud seated in an eccentric groove or slot on the clutch-ring, substantially as shown and described.

8. The combination in a bolt-cutter head of  
the barrel, the die-carrying arms, the clutch-  
ring sliding on the barrel, the links pivoted  
at one end to a die-carrying arm and at the  
5 other to a stud sliding in the clutch-ring, and  
a clamp-ring to clamp the studs in place, sub-  
stantially as described.

In testimony whereof I hereto affix my sig-  
nature in presence of two witnesses.

MICHEL D. LUEHRS.

Witnesses:

DANIEL M. LUEHRS,  
WM. G. TAYLOR.