

(No Model.)

C. S. ONDERDONK.
PAPER FEEDING DEVICE.

No. 371,473.

Patented Oct. 11, 1887.

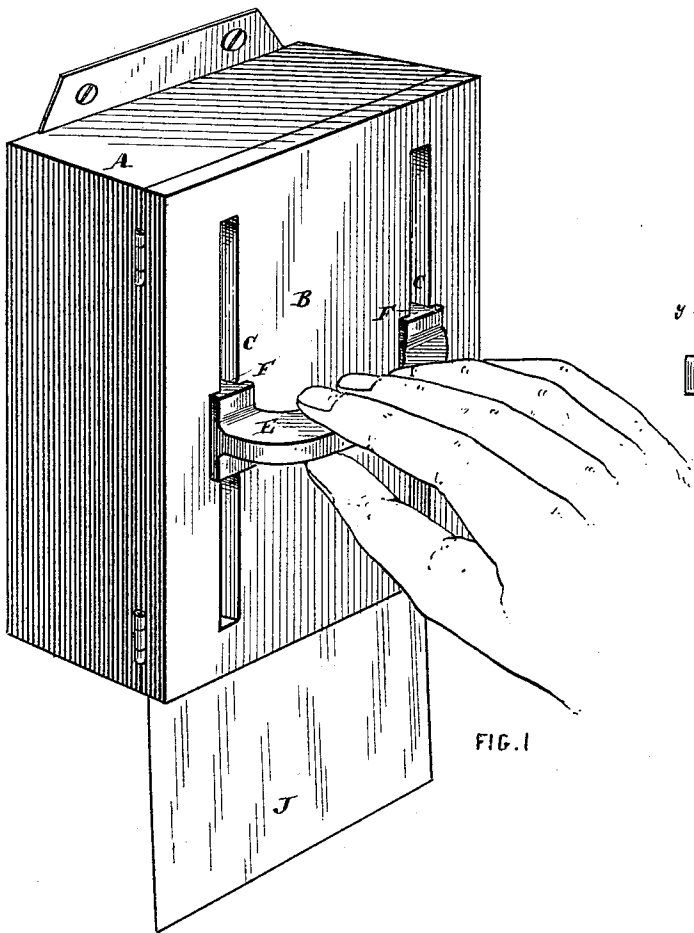

FIG. 1

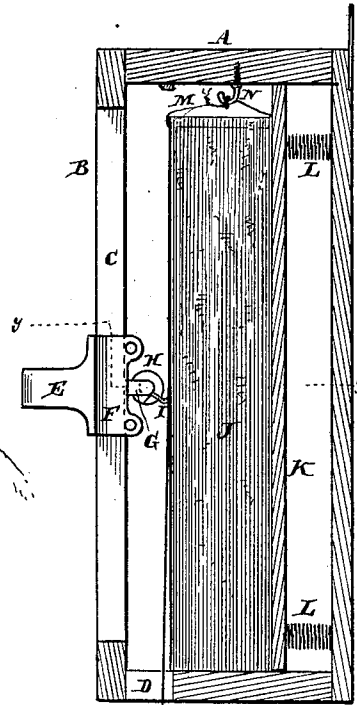

FIG. 2

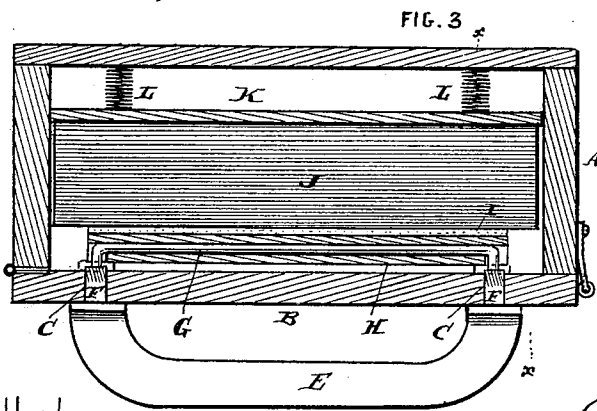

FIG. 3

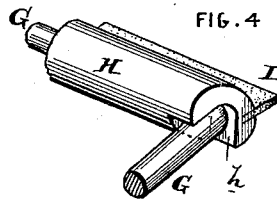

FIG. 4

Attest

Richard Smith
Joshua M. Black, Jr.

Inventor
Charles S. Onderdonk
by his attorney
Francis T. Chambers

UNITED STATES PATENT OFFICE.

CHARLES S. ONDERDONK, OF PHILADELPHIA, PENNSYLVANIA, ASSIGNOR
TO JOHN P. ONDERDONK, OF SAME PLACE.

PAPER-FEEDING DEVICE.

SPECIFICATION forming part of Letters Patent No. 371,473, dated October 11, 1887.

Application filed December 18, 1885. Serial No. 186,088. (No model.)

To all whom it may concern:

Be it known that I, CHARLES S. ONDERDONK, of Philadelphia, Pennsylvania, have invented a new and useful Improvement in Paper-Feeding Devices, of which the following is a full and true description, reference being had to the accompanying drawings, which form a part of this specification.

The object of my invention is to provide a simple and convenient device for detaching and moving forward one by one sheets of paper from a package of such sheets superimposed upon each other—like, for instance, the ordinary packages of closet-paper; and my invention consists of the peculiar device hereinafter described, which takes hold of the top sheet and draws it along by means of friction when moved in one direction, and then releases its hold and moves freely back to its initial position, and in the combination of this device with mechanism for guiding its motion, for holding the package of paper in contact with it, and for retaining the sheets below the one being moved in position.

Reference being now had to the drawings, which illustrate my invention as applied to a case or box for containing a package of closet-paper or package of circulars, Figure 1 is a perspective view of such a case, showing the operation of drawing out a sheet of paper. Fig. 2 is a sectional side elevation on the line *x x*, Fig. 3. Fig. 3 is a sectional view on the line *y y* of Fig. 2, and Fig. 4 is a perspective view of the clutching device.

A is the box or casing containing the package of paper; B, the front of the casing shown as hinged to the box A for convenience in inserting the paper.

C C are slots or guides.

D is the opening through which the paper is pushed out of the box.

E is a handle, having guides F F passing through the slots C.

G is a rod extending across the top of the box and firmly secured to the guides F of the handle E, as shown in the drawings, its ends being bent at right angles and inserted in the guides.

H is a smooth roller or section of a roller pivoted or journaled on the rod G, so as to

turn freely thereon through an arc of about ninety degrees, as shown in Fig. 4. The roller is made to extend around the bent portion of the rod G, and a notch, *h*, cut in it, the sides of which, by engaging with the upright, limit its motion in both directions. In the lower portion of the roller H is inserted or secured a strip of rubber, I, so placed with reference to the stops which limit the motion of the roller that it will extend downward when the roller is in the position shown in Figs. 2 and 4, and will be above or on a level with the smooth surface of the roller when it is turned backward.

J is a package of paper.

K is a sheet of wood or metal upon or against which the bottom of the package J rests.

L L are springs which press the package upward against the roller H.

M is a wire or string passing through the top edge of the package J; N, a hook to which the wire M is attached. When the handle E is pulled downward, the roller H, against which the paper J is constantly pressing, will revolve until the rubber I comes in contact with the top sheet. The friction between the rubber and paper is sufficient to pull the sheet away from the binding-wire M, and as the roller moves downward the paper is thrust out of the opening D, and may be withdrawn by hand or by gravity, when the handle and roller move upward again. When the device is moved upward, the rubber clutch I is automatically thrown out of contact with the paper sheets, the piece H turning upon its supporting-rod.

This device, when used with a closed box, A, will prevent any large number of sheets being taken from the package at a time; but it may be used also to feed paper to a printing-press, or for any other use for which it is desirable to feed out sheets of paper one by one.

The roller may of course be made to move up and down by mechanism as well as by hand, and it will often be convenient to attach a spring to the guides to cause the roller to return automatically to the top of the box.

It is not of course essential that the rubber clutch I should be attached to a round roller like H, the only operative part of which is

the smooth surface immediately back of the rubber. Indeed, the rubber may be connected to its reciprocating supporting-frame by any device which will cause it to press with sufficient force against the paper while moving in one direction and to travel back again substantially out of contact with the paper.

I have spoken of the clutch I as being rubber, which I believe to be the best material for it, though any similar substance which will take hold of the paper in the same way may be used as well.

I am aware that it has been suggested that paper could be removed sheet by sheet from a package by means of a friction-roller having a roughened or corrugated surface, which, being kept in contact with the upper surface of the package, would, when turned, force the sheets forward one by one in the direction of its revolution. My invention is to be distinguished from such devices by the reciprocating movement of the clutch, which enables the rubber grip to retain its hold on a single line across the sheet, instead of acting successively on different lines along its length, and which, moreover, is simpler and quicker in its operation.

In this application I do not claim the hanging of the paper by a centrally-located wire, as that forms the subject-matter of another application.

Having now described my invention, what I

claim as new, and desire to secure by Letters Patent, is—

1. In a paper-feeding device, the combination of a friction-clutch of rubber or equivalent material and reciprocating mechanism therefor, said clutch being yieldingly connected with said reciprocating mechanism, whereby the rubber is automatically withdrawn from operative contact with the paper during the return-stroke, substantially as set forth.

2. In a paper-feeding device, substantially as specified, the combination of the rubber strip I with the reciprocating smooth roller H, so adjusted upon its bearings that it can turn freely thereon through an arc sufficient to clear the rubber from contact with the paper during its backward movement.

3. In a paper-feeding device, substantially as specified, the combination, with the box A, having cover B, provided with one or more slots, C, of the handle E, having guides F, and the oscillating roller H, attached to the handle, and having a rubber strip, I.

4. In a paper-feeding device, substantially as specified, the combination of the box A, having opening D and spring bottom K, with the reciprocating and oscillating roller H, having the rubber strip I.

CHAS. S. ONDERDONK.

Witnesses:

JNO. P. ONDERDONK,
BENJ. B. COOPER.