

Feb. 27, 1951

A. MURRAY

2,543,045

CELLULAR PRINTING PLATE AND METHOD OF PRINTING

Filed May 21, 1947

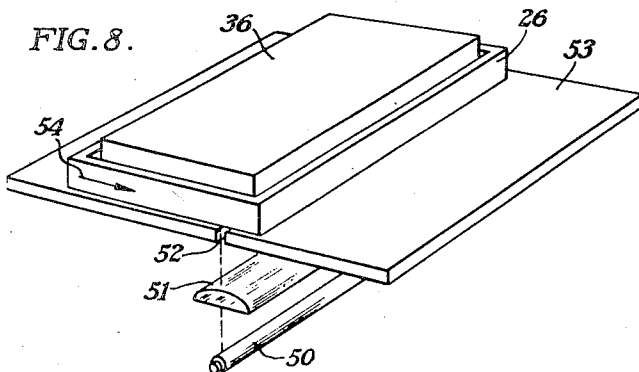
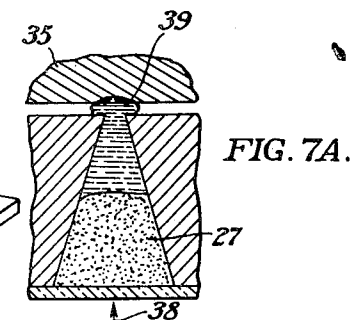
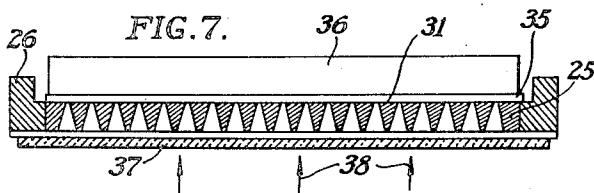
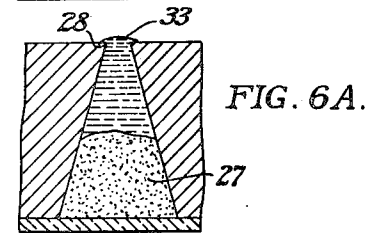
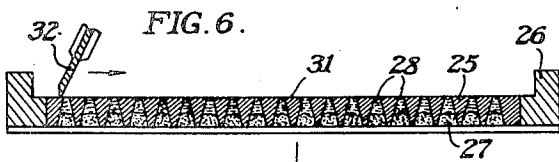
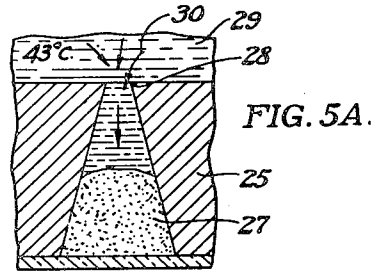
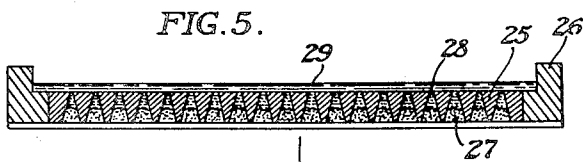
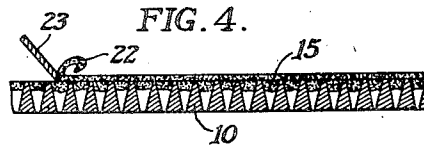
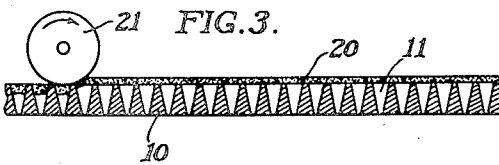
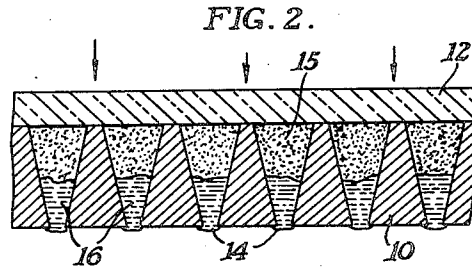
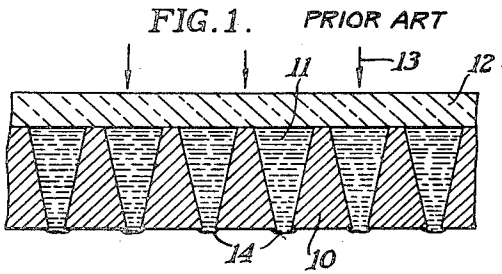

ALEXANDER MURRAY
INVENTOR

BY *Newton M. Lomas*
W. Emerson Holmes
ATTORNEY & AGENT

UNITED STATES PATENT OFFICE

2,543,045

CELLULAR PRINTING PLATE AND METHOD OF PRINTING

Alexander Murray, Rochester, N. Y., assignor to Eastman Kodak Company, Rochester, N. Y., a corporation of New Jersey

Application May 21, 1947, Serial No. 749,445

7 Claims. (Cl. 101-426)

1

2

This invention relates to an improved form of the so-called Glassey block as described by C. Q. Glassey in patent application Serial Number 745,019, filed April 30, 1947. It also relates to an improved method of printing with such blocks.

The object of the present invention is to provide greater speed of operation and a somewhat simpler method of using the Glassey block.

According to Glassey, a cellular printing plate having ink-containing cells each with a narrow opening to the printing surface of the plate is illuminated from the rear with a radiant energy image which heats the contents of the cells differentially and expels ink through the narrow openings and on to a surface to be printed. The speed of operation depends on several factors including the rate of expansion of the contents of the cells as the temperature rises. One essential feature of a printing plate according to the present invention, is the use of a plastic material having a high coefficient of thermal expansion to fill the major portion of each cell, the rest of the cell being filled with the printing ink to be expelled through the orifices. For the sake of definiteness, it is pointed out that little advantage is gained unless the plastic material has a coefficient of expansion at least twice that of the printing fluid which it replaces in the cell. White paraffin wax has a coefficient of linear expansion of about .0015 which is a cubicle coefficient of about .005, which is approximately 5 times that of ethanol.

A second important feature is the incorporation of a heat absorbing constituent in the plastic material to accelerate the conversion of radiant energy into expansion of the plastic mass.

Since the ink in each cell must be in that portion of the cell adjacent to the printing orifice and since it is desirable to have the plastic material fill as much of the rest of the cell as possible, it is not convenient to remove the wax during each printing cycle. The wax is placed in the cells preferably through relatively large rear openings which are then sealed more or less permanently by a layer of transparent material across the back of the cellular sheet. The printing plate comprises both the cellular sheet and the closure layer in this case. Also the re-inking of the cells must now be done from the front and this constitutes one novel step in the new manner of using cellular printing plates according to the present invention. As or after the plate is inked, it must be brought to a substantially uniform initial temperature and the front surface wiped with a doctor blade to remove excess ink.

According to a preferred embodiment of the invention the temperature control and the inking step are provided simultaneously by flowing a cooled ink across the front surface which ink is drawn into the cells as the contents thereof cool. It is noted that this manner of inking the plates is useful whether or not the cells contain anything in addition to the printing ink. One particular advantage of inking from the front is the fact that since no ink normally reaches the rear surface of the printing plate, the negative to be contact printed thereby may be laid directly on the rear surface. The most convenient arrangement for flowing ink across the printing plate is that in which the printing is upward, but this is not absolutely essential since methods of applying cool ink to the lower surface of a printing plate are obvious.

Another novel feature which is particularly useful in the above described method of printing but which is also applicable to all cellular printing plate systems consists of restricting the illumination of the rear surface of the plate to only part of the surface at one time and covering the whole surface by a sweeping action of the illumination. For example, in contact printing the negative is laid on or close to the rear surface of the plate and a highly intense line of light sweeps across the negative or a highly intense spot of light scans the negative, sweeping back and forth until the whole area is covered. This permits the use of much higher intensity of illumination than might otherwise be obtainable. The sweeping by a line of light may be accomplished in a press in which the paper moves forward substantially continuously, the line of light being held stationary relative to the press.

The operation of the invention and the advantages thereof will be fully understood from the following description when read in connection with the accompanying drawings, in which:

Fig. 1 illustrates one form of a cellular printing plate according to the teachings of Glassey.

Fig. 2 illustrates a similar plate modified according to the present invention.

Figs. 3 and 4 illustrate alternative methods of making the plate shown in Fig. 2.

Figs. 5, 6 and 7 constitute a flow chart of a printing cycle according to a preferred embodiment of the invention.

Figs. 5A, 6A and 7A are respectively greatly enlarged drawings of a single cell during each of the steps illustrated.

Fig. 8 illustrates the essential features of a preferred method of printing according to the invention.

3

In Fig. 1 a cellular printing plate 10 having ink filled cells 11 with narrow openings 14 to the printing surface of the plate and a transparent layer 12 closing the rear of the cells 11, is illuminated as indicated by arrows 13 with a radiant energy image which differentially heats the contents of the cells and expels ink through the openings 14 on to a sheet of paper or other surface to be printed. According to the present invention as illustrated in Fig. 2 the rate of expelling the ink is speeded up by filling the major portion of each cell with white paraffin wax 15 containing carbon black or a finely divided metal such as copper, silver, iron, nickel, etc., which accelerates the heat absorption. Elastomeric Vinylite may also be used as the propellant material. The printing fluid 16 preferably occupies only a small portion of the cell, but of course this portion must be adjacent to the orifice 14.

As shown in Fig. 3 the cellular layer 10 may be coated with a thin layer of wax or other propellant plastic 20 which is then rolled into the cells by a roller 21. Alternatively, as illustrated in Fig. 4, the wax may be applied in a slightly warm condition so that it settles into the cells but not quite to the bottom and then the excess wax 22 may be scraped away by a suitable scraper 23. In either case the cellular layer 10 is then laminated more or less permanently to a transparent layer 12 as shown in Fig. 2 and the inking of the cells in all subsequent operations is done from the front through orifices 14.

After each printing step the plate is preferably brought to a uniform temperature when re-inked and the front surface wiped free of excess ink before the next printing step. According to a preferred feature of the present invention, this is all accomplished as illustrated in Figs. 5 to 7A in a relatively simple manner. In Figs. 5 and 5A a cellular printing plate 25 is supported in a frame 26, and in this case each cell contains a wax propellant 27 which has just been expanded by the immediately previous printing operation. For example, in the shadows the temperature of the wax reached, say, 57° C. so that a large amount of ink has been driven from the orifice 28 of the cell. According to the invention the surface is then flooded with relatively cool ink 29 whose temperature is somewhat below 43° C. so that it cools the plate 25 and the wax 27 bringing the plate to a more or less uniform temperature of 43° C. and simultaneously inking the plate because the contraction of the wax 27 draws the ink into the cells as indicated by arrows 30. If it were not for this drawing action as the contents of the cells contract, it would be considerably more difficult to ink the cells from the front. As shown in Fig. 6 the printing surface 31 of the plate is then wiped with a doctor blade 32 to remove the excess ink, leaving the ink level 33 even with the orifice 28 as shown in Fig. 6A.

A sheet of paper 35 is then laid on the printing surface 31 and held there by a partly resilient block 36 which insures good contact between the paper 35 and the surface 31. A negative 37 is held in contact with the lower surface of the printing plate 25 and illuminated as indicated by arrows 38. This causes the wax 27 to expand forcing ink from the orifice 28 as indicated by the droplet 39 in Fig. 7A. This ink is printed onto the paper 35 to a density proportional to the heat absorbed by the cell.

Since it is not always convenient to illuminate a large area with sufficient intensity to print rapidly, one preferred embodiment of the inven-

4

tion uses a confined area of illumination and illuminates only part of the printing area at a time. Such an arrangement is shown in Fig. 8 wherein a light source 50 through a cylindrical lens 51 illuminates an aperture 52 in a table 53. The printing plate in its frame 26 is moved across the aperture 52 as indicated by arrow 54. Thus the whole surface of the printing plate is illuminated by a sweeping action. If the paper 35 is part of a long strip it may be arranged to pass over the roller holding it in contact with the printing plate only along a line opposite to the aperture 52. That is, the roller replaces the block 36. Such a scanning arrangement is applicable to all forms of printing which employ the Glassey cellular plate or modifications thereof.

It is to be understood that the invention is not limited to the above described structures and processes, but is of the scope of the appended claims.

I claim:

1. A printing plate comprising a sheet of solid material with cells uniformly distributed over the plate and with only one opening, a narrow one of capillary dimensions from each cell through the printing surface of the plate, the total area of the openings being less than 10 per cent of the total printing area, part of each cell away from the opening thereof being filled with a plastic material having a coefficient of thermal expansion at least twice as great as a printing fluid with which the rest of each cell is filled when printing, and the part of the plate between the cells and the back surface of the plate being transparent.

2. A printing plate according to claim 1 in which the plastic material is a paraffin wax.

3. A printing plate according to claim 1 in which the plastic material contains a heat absorbing constituent.

4. The method of printing from a cellular plate having ink containing cells each with a narrow opening of capillary dimensions to the printing surface of the plate comprising heating the contents of the cells by illuminating the rear surface of the plate with a radiant energy image absorbable by said contents, the image being negative to that to be printed to expel ink through the narrow openings and onto a surface to be printed characterized by the steps of inking the plate from the front and through the narrow openings between printing steps, bringing the plate to a substantially uniform temperature, wiping the front surface with a doctor blade to remove excess ink, and placing said front surface substantially in contact with the surface to be printed ready for the next printing step.

5. The method of printing according to claim 4 in which the steps of inking and bringing the plate to a substantially uniform temperature are performed simultaneously by flowing a cool ink across said front surface so that ink is drawn into the cells as the contents thereof cool.

6. The method of printing according to claim 4 further characterized by the illuminating the rear surface of the plate being done over only part of the surface at a time and the whole surface being covered by a sweeping action of the illumination.

7. The method of printing from a cellular plate having ink containing cells each with a narrow opening of capillary dimensions to the printing surface of the plate comprising heating the contents of the cells by illuminating the rear surface of the plate with a radiant energy image absorb-

2,543,045

5

able by said contents, the image being negative to that to be printed to expel ink through the narrow openings and onto a surface to be printed characterized by the illuminating of the rear surface of the plate being done over only part of the surface at a time and the whole surface being covered by a sweeping action of the illumination.

ALEXANDER MURRAY.

6

REFERENCES CITED

The following references are of record in the file of this patent:

UNITED STATES PATENTS

Number	Name	Date
1,838,218	Durham	Dec. 29, 1931