

(19) World Intellectual Property Organization  
International Bureau



(43) International Publication Date  
3 March 2005 (03.03.2005)

PCT

(10) International Publication Number  
WO 2005/020108 A1

(51) International Patent Classification<sup>7</sup>: G06F 17/30

L. [CA/US]; 4309 239th Place SE, Issaquah, Washington 98029 (US). ROY, Shaibal [IN/US]; 21560 SE 28th LN, Sammamish, Washington 98075 (US).

(21) International Application Number:  
PCT/US2004/005768

(74) Agents: REGAN, Christopher F. et al.; ALLEN, DYER, DOPPELT, MILBRATH & GILCHRIST, P.A., 255 S Orange Avenue Suite 1401, Orlando, FL 32801 (US).

(22) International Filing Date: 26 February 2004 (26.02.2004)

(25) Filing Language: English

(26) Publication Language: English

(30) Priority Data:  
60/494,257 11 August 2003 (11.08.2003) US  
10/778,590 13 February 2004 (13.02.2004) US

(81) Designated States (unless otherwise indicated, for every kind of national protection available): AE, AG, AL, AM, AT, AU, AZ, BA, BB, BG, BR, BW, BY, BZ, CA, CH, CN, CO, CR, CU, CZ, DE, DK, DM, DZ, EC, EE, EG, ES, FI, GB, GD, GE, GH, GM, HR, HU, ID, IL, IN, IS, JP, KE, KG, KP, KR, KZ, LC, LK, LR, LS, LT, LU, LV, MA, MD, MG, MK, MN, MW, MX, MZ, NA, NI, NO, NZ, OM, PG, PH, PL, PT, RO, RU, SC, SD, SE, SG, SK, SL, SY, TJ, TM, TN, TR, TT, TZ, UA, UG, US, UZ, VC, VN, YU, ZA, ZM, ZW.

(71) Applicant (for all designated States except US): TEAMON SYSTEMS, INC. [US/US]; 1180 NW Maple Street, Suite 201, Issaquah, Washington 98027 (US).

(72) Inventors; and

(84) Designated States (unless otherwise indicated, for every kind of regional protection available): ARIPO (BW, GH,

(75) Inventors/Applicants (for US only): GARDNER, Darren

[Continued on next page]

(54) Title: SYSTEM AND METHOD FOR CONFIGURING ACCESS TO ELECTRONIC MAILBOXES

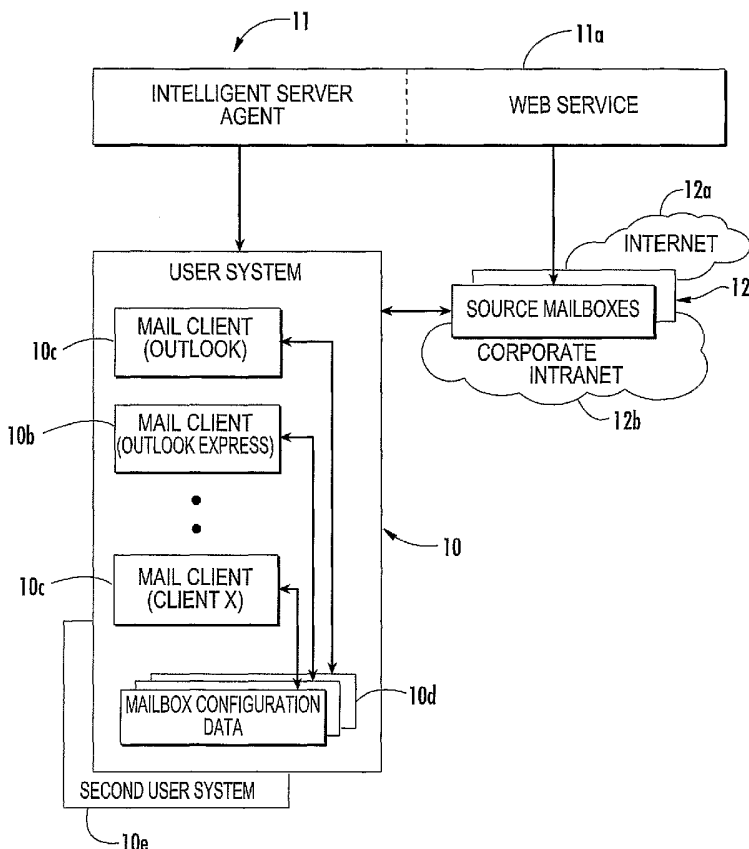

(57) Abstract: A system and method for configuring access to an electronic mailbox (See figure 1) based on limited configuration parameters received from a user (See figure 1, 10). A database stores configuration conventions for a mail domain (See figure 1, 10d). A mailbox interface module receives configuration information from a user that is limited in the configuration parameters required for accessing the electronic mailbox (See figure 1, 10c). The module retrieves configuration conventions for the mail domain from the database (See figure 1, 11) and generates sets of potentially valid configuration parameters based on the retrieved configuration conventions and user supplied configuration information for accessing the mailbox (See figure 1, 10).

WO 2005/020108 A1



GM, KE, LS, MW, MZ, SD, SL, SZ, TZ, UG, ZM, ZW), Eurasian (AM, AZ, BY, KG, KZ, MD, RU, TJ, TM), European (AT, BE, BG, CH, CY, CZ, DE, DK, EE, ES, FI, FR, GB, GR, HU, IE, IT, LU, MC, NL, PT, RO, SE, SI, SK, TR), OAPI (BF, BJ, CF, CG, CI, CM, GA, GN, GQ, GW, ML, MR, NE, SN, TD, TG).

**Published:**

— *with international search report*

*For two-letter codes and other abbreviations, refer to the "Guidance Notes on Codes and Abbreviations" appearing at the beginning of each regular issue of the PCT Gazette.*

**SYSTEM AND METHOD FOR CONFIGURING ACCESS  
TO ELECTRONIC MAILBOXES**

**Field of the Invention**

[0001] The present invention relates generally to the field of configuring access to electronic mail systems, and more particularly, to accessing automatically an electronic mailbox.

**Background of the Invention**

[0002] Electronic mail (email) has become a very important means of communication. Users of email may have one or more mailboxes that they may need to access from a variety of devices or systems and a variety of locations. Various services may also access the mailboxes. For example, some services provide a unified mailbox that allows the user to access one or more mailboxes through the unified mailbox.

[0003] Services such as Yahoo™ now provide mailbox services that automatically poll a predefined list of mailboxes to determine if new email has been received. New emails that have been received in any of the polled mailboxes are retrieved into the requesting mailbox. As a result, the user only has to check the requesting mailbox to determine if new email has arrived in any of the other mailboxes. This reduces the number of mailboxes that are required to be checked periodically. Other services allow a user to access their mailboxes through a plurality of devices such as, but not limited to, mobile phones, mobile computing devices, for

example, personal digital assistants (POA's) and other communications devices.

**[0004]** In order to access a mailbox, a valid set of configuration parameters must be specified. An essential parameter is the mailbox protocol through which access to the mailbox is achieved, since there are many different mailbox protocols in existence, such as Post Office Protocol (POP) and Internet Message Access Protocol (IMAP). Other parameters might include a mailbox server name or a mailbox login name. Each unique combination of these parameters defines a different configuration that can be used to access the mailbox. In some cases, there are multiple unique configurations that can be used to specify access to a single mailbox, whereas in other cases, only one specific configuration can be used. Typically, the user would have to determine these configuration parameters for each of the mailboxes and configure manually a web service associated with a web server to access each of the mailboxes.

**[0005]** One proposal in U.S. patent application publication no. 2002/0174194 provides a single web-based interface that gives the user access to a plurality of different message accounts on different message servers. This proposal allows email clients to access only a subset, namely messaging, of an IMAP server, and requires a user to establish all configuration parameters for the IMAP server functionality. Other similar proposals that require a user to determine and manually configure a web service for configuration parameters are disclosed in U.S. Patent No. 5,968,117 and U.S. published patent application no. 2002/0112007, where message sources are established during setup and a technical support can be

called. U.S. Patent No. 6,446,114 discloses the use of an agent that searches a user database to determine a list of messaging systems the user subscribes. The agent recalls from an application database any procedures for accessing the messaging systems and logs onto each messaging system to retrieve new messages.

**[0006]** These various services that access the user's mailboxes require configuration parameters, such as a mail host and a protocol, to access the mailbox. The vast majority of users only know their email address and password, and do not know the values of the remaining configuration parameters. If all the configuration parameters had to be specified by the user, and the user was unable to provide the configuration parameters, the web service would not be able to access the user's mailboxes and the user would be denied the service. As a result, it is important that the configuration parameters for the user's mailboxes be determined based on the limited information that the user is able to provide to the email provider or other service.

#### **Summary of the Invention**

**[0007]** It is therefore an object of the present invention to provide a system for configuring access to an electronic mailbox based on limited configuration parameters received from a user.

**[0008]** The system of the present invention configures access to an electronic mailbox based on limited configuration parameters received from a user for accessing the electronic mailbox. In one aspect of the present invention, a database stores configuration conventions related to valid configuration parameters used for accessing an electronic mailbox of a user in a mail domain. A mailbox interface module receives the

configuration information from the user that is limited in the configuration parameters required for accessing the electronic mailbox. The mailbox interface module is operative for retrieving configuration conventions from the database and generating sets of potentially valid configuration parameters based on the retrieved configuration conventions and user supplied configuration information.

**[0009]** The interface module can be operative on a web interface and a mobile device can be used by the user for inputting the configuration information, which in one aspect of the invention, could be an email address and password only for accessing the electronic mailbox of the user.

**[0010]** In yet another aspect of the present invention, the interface module is operative for generating a subset of possible configuration parameters by using heuristics of likelihood that a set of configuration parameters are valid for accessing the electronic mailbox. The heuristics comprise tracking statistics stored within the database about the number of attempts and percentage of successes using a given configuration convention. The interface module is operative for generating a subset of possible configuration parameters by also using additional user supplied configuration information. This information could be a standard protocol used for accessing the electronic mailbox, such as an internet message access protocol (IMAP) or the post office protocol (POP).

**[0011]** In yet another aspect of the present invention, the interface module attempts to access the electronic mailbox using potentially valid configuration parameters and generates new sets of potentially valid configuration parameters if the

attempts for accessing the electronic mailbox of the user from the original sets of configuration parameters were unsuccessful. The interface module then attempts access with new configuration parameters.

[0012] A method and computer-readable medium is also disclosed and set forth with the present invention.

#### Brief Description of the Drawings

[0013] Other objects, features and advantages of the present invention will become apparent from the detailed description of the invention which follows, when considered in light of the accompanying drawings in which:

[0014] FIG. 1 is a high level block diagram of a system that includes an intelligent server having a mailbox interface module operative with a user system and source mailbox, and can include various functions, including the learning of configuration conventions, configuring access to mailboxes and guessing configuration parameters, and transforming configuration conventions into configurations using context data, according to one aspect of the present invention.

[0015] FIG. 2 is a block diagram of a system for automatically learning mailbox configuration conventions, according to one aspect of the invention.

[0016] FIG. 3 is a flowchart illustrating an example of a method of automatically learning mailbox configuration conventions.

[0017] FIG. 4 is a block diagram of a system for determining configuration parameters, according to one aspect of the present invention.

[0018] FIG. 5 is a block diagram showing details of configuration conventions using different expressions as a subset.

[0019] FIG. 6 is a flow chart illustrating an example of a method of determining the mailbox configurations.

[0020] FIG. 7 is a block diagram illustrating a system for using symbolic expressions to represent conventions used for mailbox configuration parameters, according to one aspect of the present invention.

[0021] FIG. 8 is a block diagram showing an example of a representation for configuration conventions that are sets of e-mail expressions formed by symbols.

[0022] FIG. 9 is a flow chart illustrating an example of a method of generating configurations by expanding configuration conventions using context data.

[0023] FIG. 10 is a schematic block diagram illustrating an exemplary mobile wireless communications device for use in the present invention.

#### Detailed Description of the Preferred Embodiments

[0024] The present invention will now be described more fully hereinafter with reference to the accompanying drawings, in which preferred embodiments of the invention are shown. This invention may, however, be embodied in many different forms and should not be construed as limited to the embodiments set forth herein. Rather, these embodiments are provided so that this disclosure will be thorough and complete, and will fully convey the scope of the invention to those skilled in the art. Like numbers refer to like elements throughout, and prime notation is used to indicate similar elements in alternative embodiments.

[0025] The present invention advantageously overcomes the disadvantages of the prior art that was limited to enabling access to various email accounts by configuring a desktop PC or mobile unit, such as a pocket PC, and establishing all the various settings,



including the various configuration conventions and parameters, such as the ports, settings, including proxy settings, connections, email and other essential information for a POP or similar server using SMTP or other protocol.

**[0026]** The present invention advantageously allows a user to enter only a minimal set of data, such as an email address and password, and the system and method of the present invention determines through a pattern of learning and use of knowledge base what it is that one uses to access accounts and the server connections. The present invention can draw upon a database as a knowledge base and use symbolic expressions with levels of certainty to "guess" or determine mailbox configurations.

**[0027]** The present invention also allows users that have limited knowledge regarding their email account as to define their account for purposes of establishing server connections and being able to draw into one location, such as a mobile phone or personal computer, having only one email client or other means, a number of different email addresses and manage multiple mailboxes. This is advantageous because it is well known that many people have many different mailboxes that could be implemented in a variety of mailbox protocols, such as a post office protocol (POP) and different email clients and different companies.

**[0028]** The present invention has several different aspects. By using a database as a rule store and an electronic mailbox interface module as a module for learning, it is possible to automatically learn mailbox configuration conventions used by mail domains. In another aspect of the present invention, sets of potentially valid mailbox configurations can be

determined by the interface module and symbolic expressions used to represent configuration parameters.

**[0029]** It is well known that in order for a user to access the mailbox provided to them by their email provider, they must provide the correct set of configuration parameters. These parameters vary, but include such parameters as a mail host, port, login name, password, and other parameters for use of their mailbox. Email providers are free to use any convention they choose for these parameters. For example, many email providers employ the use of a "defacto standard" convention for these parameters, such as using a mail host name of "mail.<MailDomain>", where <MailDomain> represents the provider's e-mail domain (i.e., "foo.com"). Another example could be an address, such as JohnSmith@earthlink.net. The user may only know their email address and a password, for example, "password." Information not known to the normal user could be a port number; the POP3 server: pop.earthlink.net; the SMTP server: smtpauth.earthlink.net; the domain of earthlink.net; a different user name as indicated above, the FTP server: ftp-www.earthlink.net; an access ID; and DNS address: for example, 207.69.188.XXX.

**[0030]** There are, however, are also many mail providers that do not adhere to such conventions, and these mail providers use far less obvious conventions for these configuration parameters. This makes the task of determining the configuration for a user's mailbox in such a mail domain much more difficult, if not impossible. For example, if the users email address is "john.smith@foo.com", the email provider may use a less obvious convention, for example, if the login name is "jsmi". As a result, it is important to

capture the less obvious conventions that are specific to an email provider or mail domain.

**[0031]** FIG. 1 shows a high level block diagram of a user system **10** that is operative with an intelligent server **11** in one aspect of the present invention, which operates as an agent and mailbox interface module and communicates with source mailboxes **12**. The user system **10** includes various email clients **10a**, **10b** and **10c**, which in this example, correspond to an Outlook mail client, an Outlook Express mail client, and a proprietary mail client for Client X, each associated with respective source mailboxes **12**. The user system **10** also includes mailbox configuration data **10d** for each of the email clients **10a**, **10b** and **10c**. It should be understood that the various email clients could be located on different user systems, as illustrated by the second user system **10e**. The user system **10** is operative with the intelligent server **11** acting as an agent. The user system would be a wireless, mobile device, such as a held-held Blackberry unit. The source mailboxes could be located on the internet **12a**, a corporate intranet **12b**, or both. The intelligent server **11** as an agent performs various functions and can include various functional modules, and a database as a conventions data store and validator modules as will be explained below. It should also be understood that some of the functions of the intelligent server as an agent could also be downloaded to the user system and operative by the user as when inputting information into a mobile device or home computer.

**[0032]** It should be understood that the software and programming used for the present invention can vary, and different applications can be used. The intelligent server **11** can use web services technology

(shown by the area indicated as web services **11a**) and include different application services used by those skilled in the art. Web services could include a combination of programming and data, which are available from a web server for web users, or the use of other web-connected programs as provided by an application service provider. Web services could use an extensible mark-up language (XML) as a standard for formatting data to be communicated.

**[0033]** Any type of arrangement can be used to access the intelligent server **11**, including a peer-to-peer arrangement, a central server, or other architecture and communications. Also, middleware could be used. Data formats could be standardized and data exchanged using the extensive mark-up language (XML), which is the foundation for the web services description language (WSDL). Different web servers could be used, including the open source Apache or Microsoft's internet information server (IIS). Other web services could include Novel's web server for users of its netware operating system or the IBM family of Lotus domino service, for example, for IBM's OS/390 and AS/400 customers. Naturally, any web server should be able to download requests for file transfer protocol (FTP) files in a preferred embodiment.

**[0034]** The intelligent server **11** can have various import agents that are designed to retrieve configuration data from email clients **10a**, **10b** and **10c**, including Eudora and Netscape besides the Outlook and Outlook Express email clients as illustrated. The intelligent server could include a Messaging Application Programming Interface (MAPI) to retrieve any configuration data for a MAPI-compliant email client. MAPI provides the application programming

interface (API) to ensure system independence for messaging applications. A layer of functionality could be provided between applications at any underlying messaging systems and act as messaging middleware. MAPI-compliant applications could communicate through a MAPI subsystem to MAPI service providers that perform requested actions for clients and pass data back through a MAPI system to a MAPI client. Any mailbox configuration data **10d** could reside in a configuration registry of the user system **10**. Another example embodiments, data could reside in email client specific configuration storage.

**[0035]** In the user system, the Microsoft Outlook Express mail client **10b** can access source mailboxes **12** that use the Post Office Protocol (POP) or Internet Mail Access Protocol (IMAP). POP, of course, is the internet mail server protocol that provides incoming message storage. The more recent protocol is POP3. POP is operative with a Simple Mail Transfer Protocol (SMTP). Any mail server could run both protocols if it is to receive, store and forward messages. The SMTP protocol exchanges messages from one mail server to another and hands messages to the required POP server for an email mailbox. A POP server can receive a message and hold it until another POP server is available. The IMAP version 4 also uses the SMTP transport mechanism, but it is a more flexible protocol because IMAP allows users to store mail on a mail server without downloading all new messages to a local machine. Internet mail service, of course, run SMTP and either POP or IMAP and receives incoming messages from any source without identity checking. Thus, mail can be selectively downloaded and read, message headers reviewed, hierarchical message stores built, address

book supported, and documents linked, authenticated and searched.

**[0036]** The intelligent server **11** could generate configuration data objects and format data objects using an extensible mark-up language (XML) for submission to various XML-compliant web services. The server and web service could be a simple object access protocol (SOAP) compliant service.

**[0037]** XML, of course, as an extensive mark-up language, is a subset of the standard generalized mark-up language (SGML) would allow data to be stored and published on websites and be richer in presentation. Custom tags could be created to define the content of documents. Common information formats could be created and the format and data shared on the internet, corporate internets and/or other networks. The mark-up symbols in XML could be unlimited and self-defining. The channel definition format (CDF) could describe any channel and a specific CDF file can contain data that specifies an initial web page and how it can be updated.

**[0038]** SOAP allows one program running in one kind of operating system to communicate with the program in the same or another type of operating system by using HTTP and XML for information exchange. SOAP could specify how to encode an HTTP header in an XML file, thus, allowing one computer to call a program in another computer and pass data, while also dictating how it can return a response. SOAP is advantageous to allow data to pass through firewall servers that screen-out requests other than those for known applications to a designated port. SOAP is an XML-based protocol that has at least three parts, including: (a) an envelope to define a framework for

describing what is in a message; (b) a set of encoding rules for expressing application-defined data types; and (c) a convention for representing remote procedure calls and responses.

**[0039]** The intelligent server **11** could include software that is implemented as an ActiveX control as a component object model (COM) and provide a framework for building software components that communicate with each other. ActiveX controls could be automatically downloaded and executed by a web browser. Distributed object applications could be built in active web pages and ActiveX controls could be downloaded to different browsers and clients. ActiveX controls could be held in a web browser as a container and distributed over an internet **12a** or corporate intranet **12b**. ActiveX controls could also manage and update web content and client systems and work closely with a user interface of a targeted operating system. Java applets or similar component objects could also be used instead of ActiveX controls. It should be understood for purposes of the present invention that an object model control could also be any type of dynamic link library (DLL) module that runs in a container as an application program using a component object model program interface.

**[0040]** In one aspect of the present invention, the less obvious conventions used by a mail domain are automatically learned and stored in a conventions store. Thus, the configuration parameters for subsequent users with mailboxes that belong to this mail domain can be determined based on the automatically learned conventions in the conventions store.

[0041] FIG. 2 illustrates a system for automatically learning conventions used by mail domains according to one aspect of the present invention. The system is part of the intelligent server **11**, which includes a validator module **13** that determines a valid set of configuration parameters **14**. The server includes a learner module **15**, which accepts the valid set of configuration parameters **14** and generates configuration conventions **16**. A configuration conventions store **18** is operative as a database preferably part of the server, but could be separate. It stores the conventions for each mail domain. The learner module **15** is operative with a rules store **17** as a database of different rules.

[0042] The validator module **13** determines a valid set of configuration parameters **14** for a respective mailbox based on a limited number of configuration parameters provided by the user. In an example embodiment, the validator module **13** may try to access the respective mailbox using a set of best guesses (estimates) for the configuration parameters as provided by the service that invokes the validator module **13**. In the example embodiment, if the access attempt fails, the validator module **13** may request additional information from the user until the validator module **13** has a valid set of configuration parameters. The validator module **13** accesses the mailbox being configured by using the access protocol relevant to the mailbox.

[0043] In an example embodiment, the validator module **13** would use POP to access a POP enabled mailbox to verify that the configuration parameters **14** are valid. In other example embodiments, the validator module **13** may use IMAP to access IMAP enabled



mailboxes. As is obvious to those skilled in the art, there are many access protocols that may be used to access mailboxes. After attempting to validate the configuration parameters **14**, the validator module **13** returns status information and the valid set of configuration parameters **14**.

**[0044]** The learner module **15** accepts the configuration parameters **14** and generates the configuration convention **16** for the configuration parameters **14**. The configuration convention **16** is a manner of formatting the conventions used for configuration parameters for storage in the configuration convention store **18**. In an example embodiment, if the users email address is "john.smith@foo.com", and the login name parameter required by the relevant mail host is "jsmi", an expression within the configuration convention **16** for the login name parameter may be <FirstName(1)><LastName(3)>. As is obvious to one skilled in the art, a variety of formats could be used in implementing a configuration convention **16**. The learner module **15** may apply certain tests to the configuration parameters **14** to ensure that the configuration parameters **14** are credible. In an example embodiment, the learner module **15** will only learn conventions in cases where the mail host is in the same mail domain as the email address of the user, to avoid attempts by "hackers" to pollute the learned configuration conventions **16**. Other tests are envisioned to ensure the integrity of the learned configuration conventions **16**. The learner module **15** may also apply rules that are stored in the rules store **17**. These rules may be based on business criteria or other relevant criteria. In an example embodiment, the

rules may indicate that certain conventions are not to be learned for security reasons.

**[0045]** Configuration conventions **16** that are deemed acceptable by the learner module **15** are then stored in the configuration conventions store **18**. In an example embodiment, the configuration conventions store **18** may include standard configuration conventions applicable to all domains, as well as one or more of the automatically learned configuration conventions **16** for each mail domain. Mail domains may have more than one associated configuration convention, as there may be multiple ways and protocols in which the mailbox on the mail domain may be accessed.

**[0046]** Services may then access the configuration conventions **16** from the configuration convention store **18** to generate a list of potential sets of configuration parameters when configuring access to one or more of the user mailboxes.

**[0047]** FIG. 3 is a flowchart illustrating one example of a method of learning the configuration conventions. In step **22**, the validator module **13** attempts to determine the set of configuration parameters **14** that allow the validator module **13** to access the mailbox. The validator module **13** then returns the status of the validation attempt and the valid set of configuration parameters **14**. In step **24**, the learner module **15** generates configuration conventions **16** based on the configuration parameters **14**. The learner module **15** may apply a set of tests to the configuration parameters **14** and may also apply a set of rules stored in the rules store **17**, to the configuration parameters **14**. In step **26**, the configuration conventions **16** are stored in the configuration convention store **18**.

**[0048]** It should be understood that the system and method for learning configuration parameters as described may be applied to configuration parameters for services other than mailbox access.

**[0049]** As noted before, based on empirical evidence, the vast majority of email providers adhere to a number of conventions when it comes to the configuration parameters used to access mailboxes. Almost all of the POP mail hosts in existence today are prefixed with "mail.", "pop.", or "pop3.". It is likely that a user with an email address of "john.smith@foo.com" would be able to access their POP-enabled mailbox through the host named "mail.foo.com", "pop.foo.com" or "pop3.foo.com". In one aspect of the present invention, these conventions are captured in a data store and it is possible for the service that requires access to the user's mailbox to use the conventions to generate potentially valid sets of configuration parameters. The server can then attempt to determine a valid set of configuration parameters that can be used to access the user's mailbox. The present invention can also determine the set of configuration parameters for the user's mailbox when the user only provides an email address and password. The system and method of the present invention can also successfully determine the configuration parameters in most cases. As new conventions are introduced or are discovered, they may be easily added to the data store.

**[0050]** In one aspect of the present invention shown in FIG. 4, a guesser or determination module **32** is part of the server **11** and operative as the mailbox interface module and generates possible sets of configuration parameters **34** based on user supplied configuration information **30**, coupled with configuration conventions

**16** stored in the configuration conventions data store **18**. Services may then use the sets of configuration parameters **34** to determine the correct set of configuration parameters required to access the user's mailbox.

**[0051]** FIG. 5 shows further details of the configuration conventions **16**. It should be understood that configuration conventions are sets of e-mail expressions formed by symbols, which can also be literals, such as a port number. In an example embodiment, a configuration convention **16** may comprise an expression for the server name parameter and an expression for the login name parameter. If, in the example embodiment, the email provider uses the login name "jsmith" and the mail domain "mail.foo.com" given an email address "john.smith@foo.com", the login name expression in the configuration convention **16** may be <FirstName(1)><LastName>, while the server name expression may be "mail.<MailDomain>". In this example, the number in brackets within the expression <FirstName(1)>, represents the number of characters to be used from the parameter <FirstName>, ie. "j". As is obvious to one skilled in the art, a variety of different symbolic representations may be used to represent the conventions for configuration parameters. The configuration conventions data store **18** stores the configuration conventions **16**. As new conventions are introduced or discovered, they may be easily added to the configuration conventions store **18**.

**[0052]** The module **32** generates the sets of possible configuration parameters **34** based on user-supplied information **30**, and relevant configuration conventions **16** from the configuration conventions data store **18**. In many cases, the users email address provides

sufficient information to be able to generate an accurate set of configuration parameters. In the example embodiment, given the email address "jane.doe@foo.com", the module **32** would use the configuration conventions **16** to generate the possible configuration parameters **34** "jdoe" for the login name, and "mail.foo.com" for the server name.

**[0053]** Email providers use many conventions when determining configuration parameters, and as a result, the module **32** generates many sets of possible configuration parameters **34**. To reduce the number of sets generated, the module **32** may only generate a subset of the sets of possible configuration parameters **34** based on additional user information, or based on heuristics of likelihood **33** that a given set of configuration parameters **34** may be successful under a given scenario. In an example embodiment, the user may indicate that only configuration conventions **16** with a protocol expression **39** of "IMAP" should be considered. In the example, the heuristics **33** could include tracking statistics about the number of attempts and percentage of successes using a given configuration convention **16**, and thereby only generate possible configuration parameters **34** based on this configuration convention **16** if certain conditions are met.

**[0054]** FIG. 6 is a flowchart illustrating an example of a method of guessing possible configuration parameters **34** for configuring access to the users mailbox. In step **40**, the module **32** receives user configuration information **30**. In step **42**, the module **32** retrieves relevant configuration conventions **16** from the configuration conventions data store **18**. In step **44**, the module **32** generates sets of possible configuration parameters **34** based on the configuration

conventions **16** and the user supplied information **30**. In this step **44**, the module **32** would typically only generate a subset of the possible configuration parameters **34** by using either heuristics of likelihood **33** that a set of configuration parameters **34** would be valid, or by using additional user supplied information **30**.

**[0055]** It should be understood that the system and method for guessing configuration parameters, according to one aspect of the present invention, may be applied to configuration parameters for services other than mailbox access.

**[0056]** Although many email providers adhere to fairly standard conventions for configuration parameters, such as naming the mail host "mail.<MailDomain>" and matching the login name to the email address, there are many other email providers that employ less obvious conventions, such as setting the login name to be <FirstName(1)><LastName(3)>, which in the case of the user with e-mail address of "john.smith@foo.com" would translate to the login name of "jsmi". In the case of protocols that use uniform resource locators (URL) to indicate the location of the mailbox, the conventions are even less standard, since the login names are often embedded in the middle of the URL.

**[0057]** By capturing these conventions in the data store, it is possible for the service that requires access to the user's mailbox to use the conventions to generate potentially valid sets of configuration parameters, and then attempt to determine a valid set of configuration parameters that can be used to access the user's mailbox. Therefore, it is possible to determine the set of configuration parameters for the

user's mailbox even if the user is unable to provide all of the necessary configuration information. All that may be required from the user is an email address and password, from which the system may be able to successfully determine the configuration parameters in most cases. As new conventions are introduced or are discovered, they may be easily added to the data store.

**[0058]** In one aspect of the present invention, the configuration parameters are represented using symbolic expressions, which may then be retained in the configuration conventions data store **18** for use by the service. This allows the service to draw configuration conventions from the data store, and using context data, to construct a valid set of configuration parameters that can be used to access mailboxes.

**[0059]** FIG. 7 illustrates an example of a system of the present invention for generating configurations that comprise sets of configuration parameters **54**. A transformer module **52** as part of server **11** takes configuration conventions **16** stored in a configuration conventions data store **18** and expands them to generate configuration parameters **54** based on user supplied context data **50**.

**[0060]** FIG. 8 shows further details of the symbolic representation of configuration conventions **16**. The configuration conventions **16** symbolically represent the conventions used by email providers for a set of configuration parameters. The configuration conventions **16** comprise expressions **39** that represent individual configuration parameters using symbols **57**. In an example embodiment, the configuration convention **16** may be formed as an expression for the server name parameter, an expression for the login name parameter, and an expression for the mail protocol. If, in the

example embodiment, the email provider uses the login name "jsmi" and the mail domain "mail.foo.com" given an email address "john.smith@foo.com", the login name expression in the configuration convention **16** may be "<FirstName(1)><LastName(3)>", while the server name expression may be "mail.<MailDomain>". In this example, the number in brackets within the symbol **57** "<FirstName(1)>", represents the number of characters to be used from the users first name parameter, i.e., "j". Similarly, the number in brackets in a symbol **57** "<LastName(3)>" represents the number of characters to be used from the users last name, ie. "smi". As is obvious to one skilled in the art, a variety of different symbolic representations may be used to represent the conventions for configuration parameters. The choice of expressions **39** can be quite arbitrary, and are only limited by the requirement that the expression **39** can be expanded into a configuration parameter based on the context data **50** supplied to the transformer module **52**.

**[0061]** The configuration conventions data store **18** stores the configuration conventions **16**. As new conventions are introduced or discovered, they may be easily added to the configuration conventions data store **18**.

**[0062]** The transformer module **52** expands the individual expressions **39** into configuration parameters by expanding each symbol **57** into its corresponding value using context data **50**. In an example embodiment, a configuration convention **16** may comprise the mail protocol expression **39a**, "POP", the server name expression **39b** "mail.<MailDomain>" and the login name expression **39c** "<FirstName(1)><LastName(3)>", for example, as shown in FIG. 5 for a plurality of



expressions. If the transformer module **52** were provided with the context data **50** comprising the email address "john.smith@foo.com", the transformer module **52** would infer the mail domain as "foo.com" from the email address. It would then generate the configuration parameters **34** of "POP" for the mail protocol, "mail.foo.com" for the server name, and "jsmi" for the login name.

**[0063]** FIG. 9 is an example of a flowchart illustrating a method of generating configurations by expanding expressions **39** using context data **50**. In step **60**, the transformer module **52** receives context data **50**. In step **62**, the transformer module **52** infers the mail domain for the users mailbox, and retrieves the relevant configuration conventions **16**. In step **64**, the transformer module **52** expands the symbols **57** within the expressions **39** of the configuration convention **15** using the context data **50**, to generate configurations that are formed by sets of configuration parameters **54**.

**[0064]** An exemplary hand-held mobile wireless communications device **1000** that can be used in the present invention is further described in the example below with reference to FIG. 10. The device **1000** includes a housing **1200**, a keyboard **1400** and an output device **1600**. The output device shown is a display **1600**, which is preferably a full graphic LCD. Other types of output devices may alternatively be utilized. A processing device **1800** is contained within the housing **1200** and is coupled between the keyboard **1400** and the display **1600**. The processing device **1800** controls the operation of the display **1600**, as well as the overall operation of the mobile device **1000**, in response to actuation of keys on the keyboard **1400** by the user.

[0065] The housing **1200** may be elongated vertically, or may take on other sizes and shapes (including clamshell housing structures). The keyboard may include a mode selection key, or other hardware or software for switching between text entry and telephony entry.

[0066] In addition to the processing device **1800**, other parts of the mobile device **1000** are shown schematically in FIG. 10. These include a communications subsystem **1001**; a short-range communications subsystem **1020**; the keyboard **1400** and the display **1600**, along with other input/output devices **1060**, **1080**, **1100** and **1120**; as well as memory devices **1160**, **1180** and various other device subsystems **1201**. The mobile device **1000** is preferably a two-way RF communications device having voice and data communications capabilities. In addition, the mobile device **1000** preferably has the capability to communicate with other computer systems via the Internet.

[0067] Operating system software executed by the processing device **1800** is preferably stored in a persistent store, such as the flash memory **1160**, but may be stored in other types of memory devices, such as a read only memory (ROM) or similar storage element. In addition, system software, specific device applications, or parts thereof, may be temporarily loaded into a volatile store, such as the random access memory (RAM) **1180**. Communications signals received by the mobile device may also be stored in the RAM **1180**.

[0068] The processing device **1800**, in addition to its operating system functions, enables execution of software applications **1300A-1300N** on the device **1000**. A predetermined set of applications that control basic

device operations, such as data and voice communications **1300A** and **1300B**, may be installed on the device **1000** during manufacture. In addition, a personal information manager (PIM) application may be installed during manufacture. The PIM is preferably capable of organizing and managing data items, such as e-mail, calendar events, voice mails, appointments, and task items. The PIM application is also preferably capable of sending and receiving data items via a wireless network **1401**. Preferably, the PIM data items are seamlessly integrated, synchronized and updated via the wireless network **1401** with the device user's corresponding data items stored or associated with a host computer system. Communication functions, including data and voice communications, are performed through the communications subsystem **1001**, and possibly through the short-range communications subsystem. The communications subsystem **1001** includes a receiver **1500**, a transmitter **1520**, and one or more antennas **1540** and **1560**. In addition, the communications subsystem **1001** also includes a processing module, such as a digital signal processor (DSP) **1580**, and local oscillators (LOs) **1601**. The specific design and implementation of the communications subsystem **1001** is dependent upon the communications network in which the mobile device **1000** is intended to operate. For example, a mobile device **1000** may include a communications subsystem **1001** designed to operate with the Mobitex™, Data TAC™ or General Packet Radio Service (GPRS) mobile data communications networks, and also designed to operate with any of a variety of voice communications networks, such as AMPS, TDMA, CDMA, PCS, GSM, etc. Other types of data and voice networks, both separate and

integrated, may also be utilized with the mobile device **1000**.

**[0069]** Network access requirements vary depending upon the type of communication system. For example, in the Mobitex and DataTAC networks, mobile devices are registered on the network using a unique personal identification number or PIN associated with each device. In GPRS networks, however, network access is associated with a subscriber or user of a device. A GPRS device therefore requires a subscriber identity module, commonly referred to as a SIM card, in order to operate on a GPRS network.

**[0070]** When required network registration or activation procedures have been completed, the mobile device **1000** may send and receive communications signals over the communication network **1401**. Signals received from the communications network **1401** by the antenna **1540** are routed to the receiver **1500**, which provides for signal amplification, frequency down conversion, filtering, channel selection, etc., and may also provide analog to digital conversion. Analog-to-digital conversion of the received signal allows the DSP **1580** to perform more complex communications functions, such as demodulation and decoding. In a similar manner, signals to be transmitted to the network **1401** are processed (e.g. modulated and encoded) by the DSP **1580** and are then provided to the transmitter **1520** for digital to analog conversion, frequency up conversion, filtering, amplification and transmission to the communication network **1401** (or networks) via the antenna **1560**.

**[0071]** In addition to processing communications signals, the DSP **1580** provides for control of the receiver **1500** and the transmitter **1520**. For example,

gains applied to communications signals in the receiver **1500** and transmitter **1520** may be adaptively controlled through automatic gain control algorithms implemented in the DSP **1580**.

**[0072]** In a data communications mode, a received signal, such as a text message or web page download, is processed by the communications subsystem **1001** and is input to the processing device **1800**. The received signal is then further processed by the processing device **1800** for an output to the display **1600**, or alternatively to some other auxiliary I/O device **1060**. A device user may also compose data items, such as e-mail messages, using the keyboard **1400** and/or some other auxiliary I/O device **1060**, such as a touchpad, a rocker switch, a thumb-wheel, or some other type of input device. The composed data items may then be transmitted over the communications network **1401** via the communications subsystem **1001**.

**[0073]** In a voice communications mode, overall operation of the device is substantially similar to the data communications mode, except that received signals are output to a speaker **1100**, and signals for transmission are generated by a microphone **1120**. Alternative voice or audio I/O subsystems, such as a voice message recording subsystem, may also be implemented on the device **1000**. In addition, the display **1600** may also be utilized in voice communications mode, for example to display the identity of a calling party, the duration of a voice call, or other voice call related information.

**[0074]** The short-range communications subsystem enables communication between the mobile device **1000** and other proximate systems or devices, which need not necessarily be similar devices. For example, the

short-range communications subsystem may include an infrared device and associated circuits and components, or a Bluetooth™ communications module to provide for communication with similarly-enabled systems and devices.

**[0075]** It will be appreciated that the above description relates to preferred embodiments by way of example only. Many variations on the systems and methods described above will be obvious to those knowledgeable in the field, and such obvious variations are within the scope of the invention as described, whether or not expressly described.

**[0076]** For example, the system and method for learning and guessing configuration parameters may be applied to configuration parameters for services other than mailbox access. Symbolic expressions could be used to represent conventions for configuration parameters for services other than email and mailbox access.

**[0077]** This application is related to copending patent applications entitled, "**SYSTEM AND METHOD FOR GENERATING CONFIGURATIONS USED FOR ACCESSING ELECTRONIC MAILBOXES,**" and "**SYSTEM AND METHOD FOR AUTOMATICALLY LEARNING MAILBOX CONFIGURATION CONVENTIONS,**" which are filed on the same date and by the same assignee and inventors, the disclosures which are hereby incorporated by reference.

**[0078]** Many modifications and other embodiments of the invention will come to the mind of one skilled in the art having the benefit of the teachings presented in the foregoing descriptions and the associated drawings. Therefore, it is understood that the invention is not to be limited to the specific embodiments disclosed, and that modifications and

embodiments are intended to be included within the scope of the appended claims.

**THAT WHICH IS CLAIMED IS:**

1. A system for configuring access to an electronic mailbox comprising:
  - a database that stores configuration conventions related to configuration parameters used for accessing an electronic mailbox; and
  - a mailbox interface module for receiving configuration information from the user that is limited in the configuration parameters required for accessing the electronic mailbox, wherein said mailbox interface module is operative for retrieving configuration conventions for a mailbox domain from the database and generating sets of potentially valid configuration parameters.
2. A system according to Claim 1, and further comprising a web service on which the mailbox interface module is operative.
3. A system according to Claim 1, wherein said configuration information received from a user comprises an email address and password.
4. A system according to Claim 1, and further comprising a mobile device on which the user inputs the configuration information.
5. A system according to Claim 1, wherein the mailbox interface module is operative for generating a subset configuration parameters by using heuristics of likelihood that a set of configuration parameters are valid.
6. A system according to Claim 5, wherein the heuristics of likelihood comprise tracking statistics stored within the database about the number of attempts and percentage of successes using a given configuration convention for a mail domain.



7. A system according to Claim 5, wherein the interface module is operative for generating a subset of possible configuration parameters using additional user supplied configuration information.

8. A system according to Claim 7, wherein the additional user supplied configuration information comprises information relating to a standard protocol used for accessing the electronic mailbox.

9. A system according to Claim 8, wherein said standard protocol comprises one of at least the Internet Message Access Protocol (IMAP) or the Post Office Protocol (POP).

10. A system according to Claim 1, wherein the configuration conventions comprise expressions formed by symbols represents individual configuration parameters.

11. A method of configuring access to an electronic mailbox comprising:

receiving configuration information from a user that is limited in the configuration parameters required for accessing the electronic mailbox of the user in a mailbox domain;

retrieving configuration conventions related to valid configuration parameters from a database based on the configuration information received from the user; and

generating sets of potentially valid configuration parameters based on the retrieved configuration conventions and the user supplied configuration information.

12. A method according to Claim 11, wherein the step of receiving configuration information from a user comprises the step of receiving an email address and password.

13. A method according to Claim 11, and further comprising the step of retrieving configuration information from a mobile device used by a user.

14. A method according to Claim 11, and further comprising the step of generating a subset of possible configuration parameters by using heuristics of likelihood that a set of configuration parameters would be valid for accessing the electronic mailbox.

15. A method according to Claim 14, wherein said heuristics comprise tracking statistics about the number of attempts and percentage of successes using a given configuration convention.

16. A method according to Claim 15, and further comprising the step of generating a subset of possible configuration parameters by using additional user supplied configuration information.

17. A method according to Claim 16, wherein said additional user supplied information comprises information relating to the standard protocol used for accessing the electronic mailbox.

18. A computer-readable medium comprising a mailbox interface module for receiving configuration information from the user that is limited in the configuration parameters required for accessing the electronic mailbox of the user and operative for accessing configuration conventions from a database and generating sets of potentially valid configuration parameters based on the retrieved configuration conventions and user supplied configuration information.

19. A computer-readable medium according to Claim 18, wherein the configuration conventions comprise expressions formed by symbols representing individual configuration parameters.

20. A computer-readable medium according to Claim 18, wherein the mailbox interface module is operative as a web server.

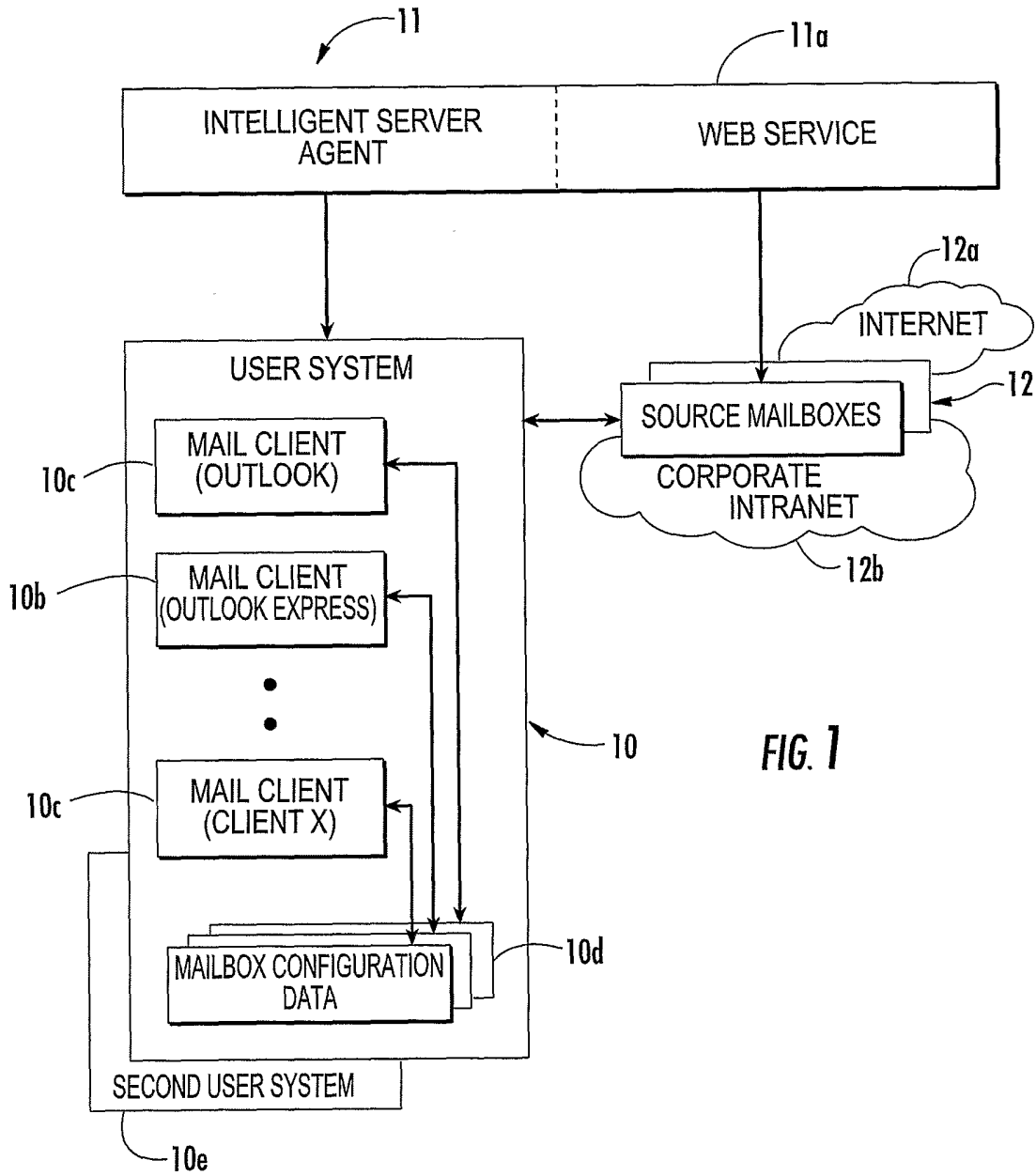
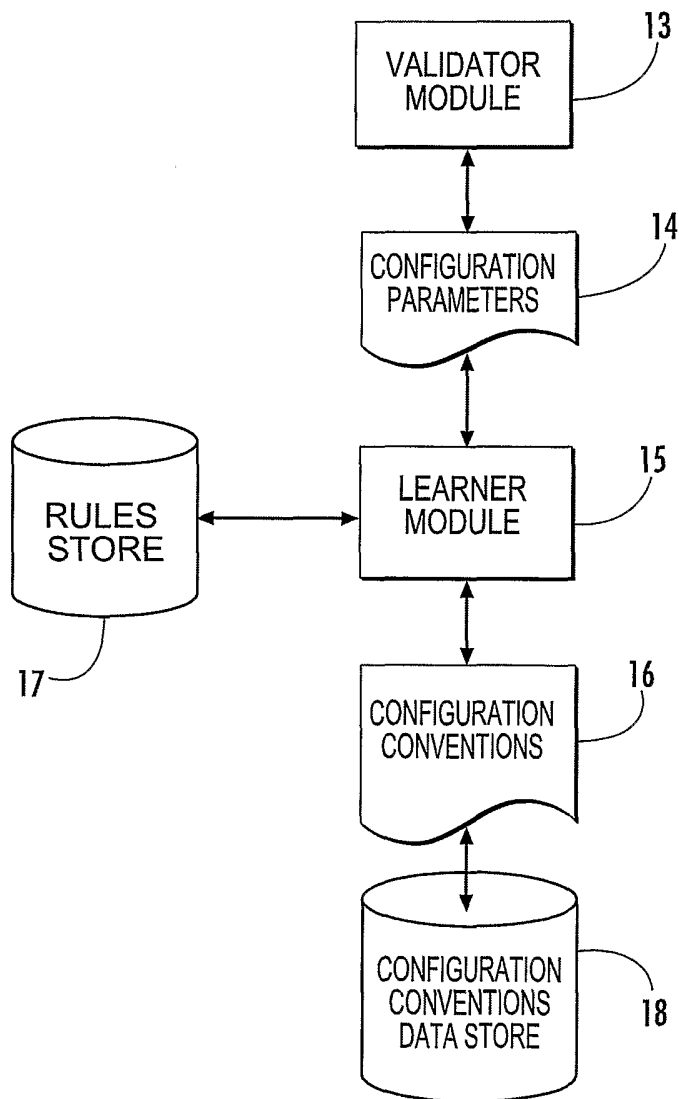
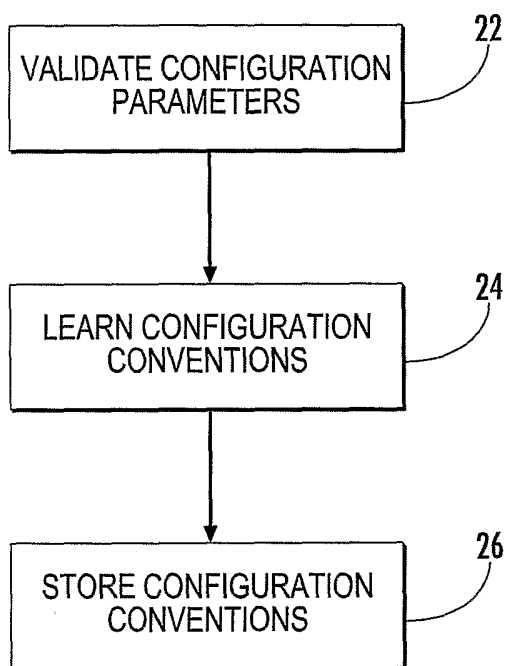

FIG. 1



**FIG. 2**



**FIG. 3**

4/8

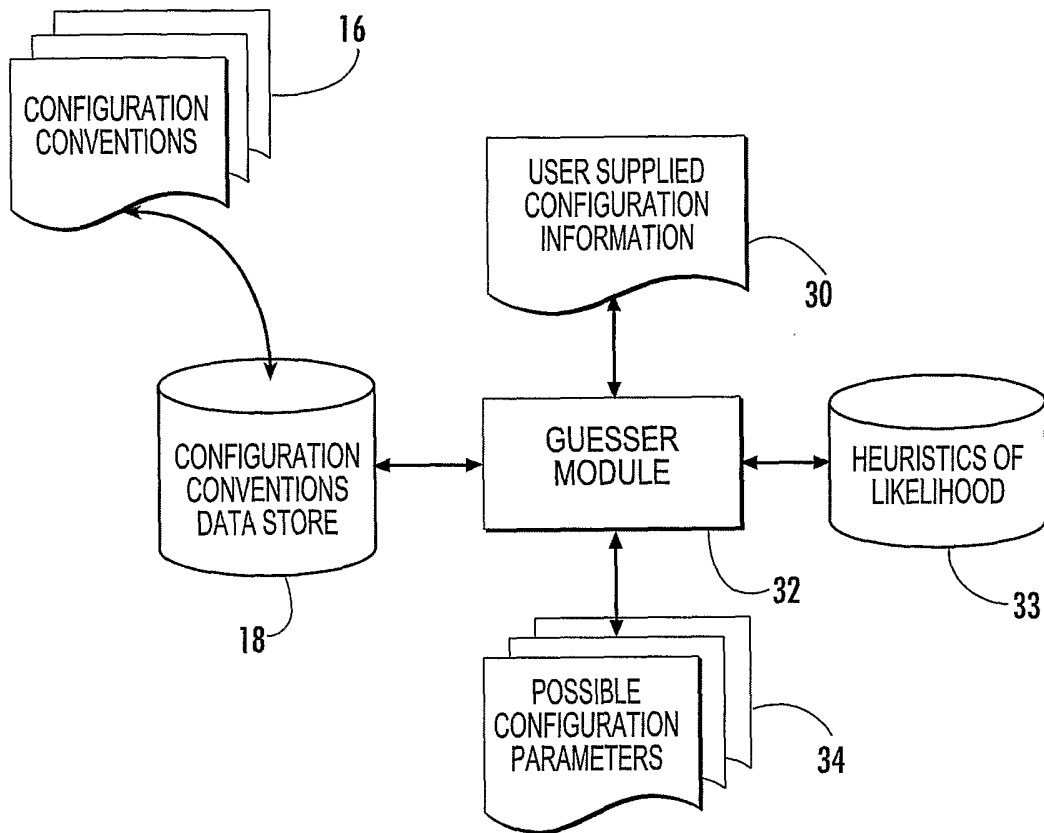

FIG. 4

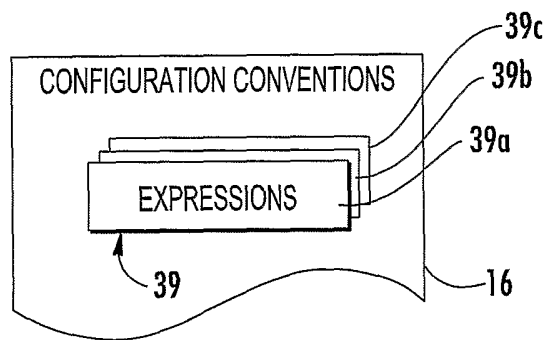
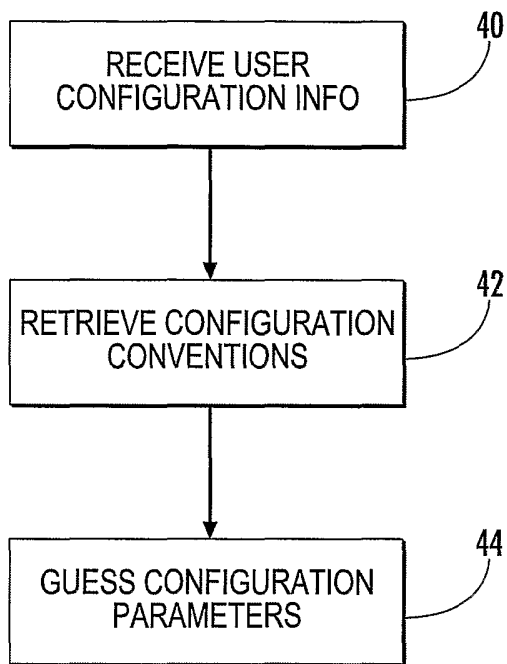

FIG. 5



**FIG. 6**



6/8

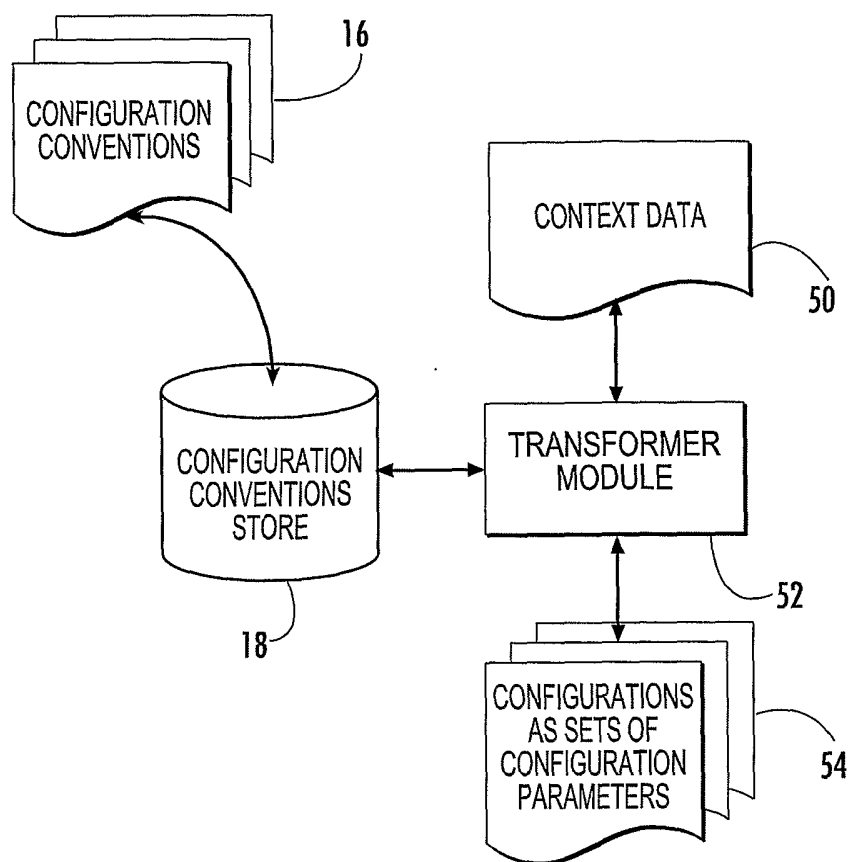

FIG. 7

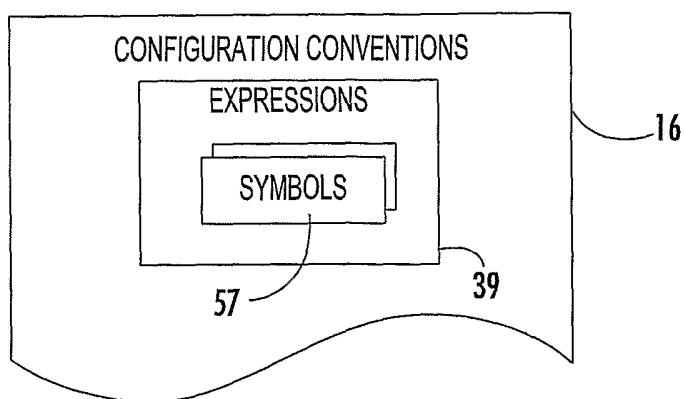

FIG. 8

7/8

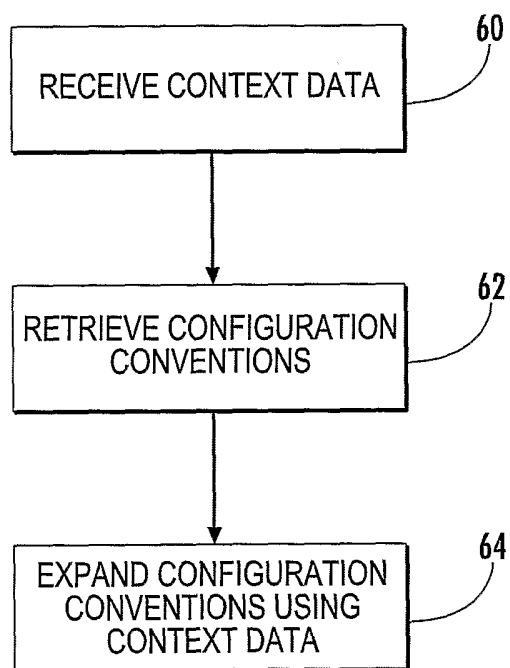

FIG. 9

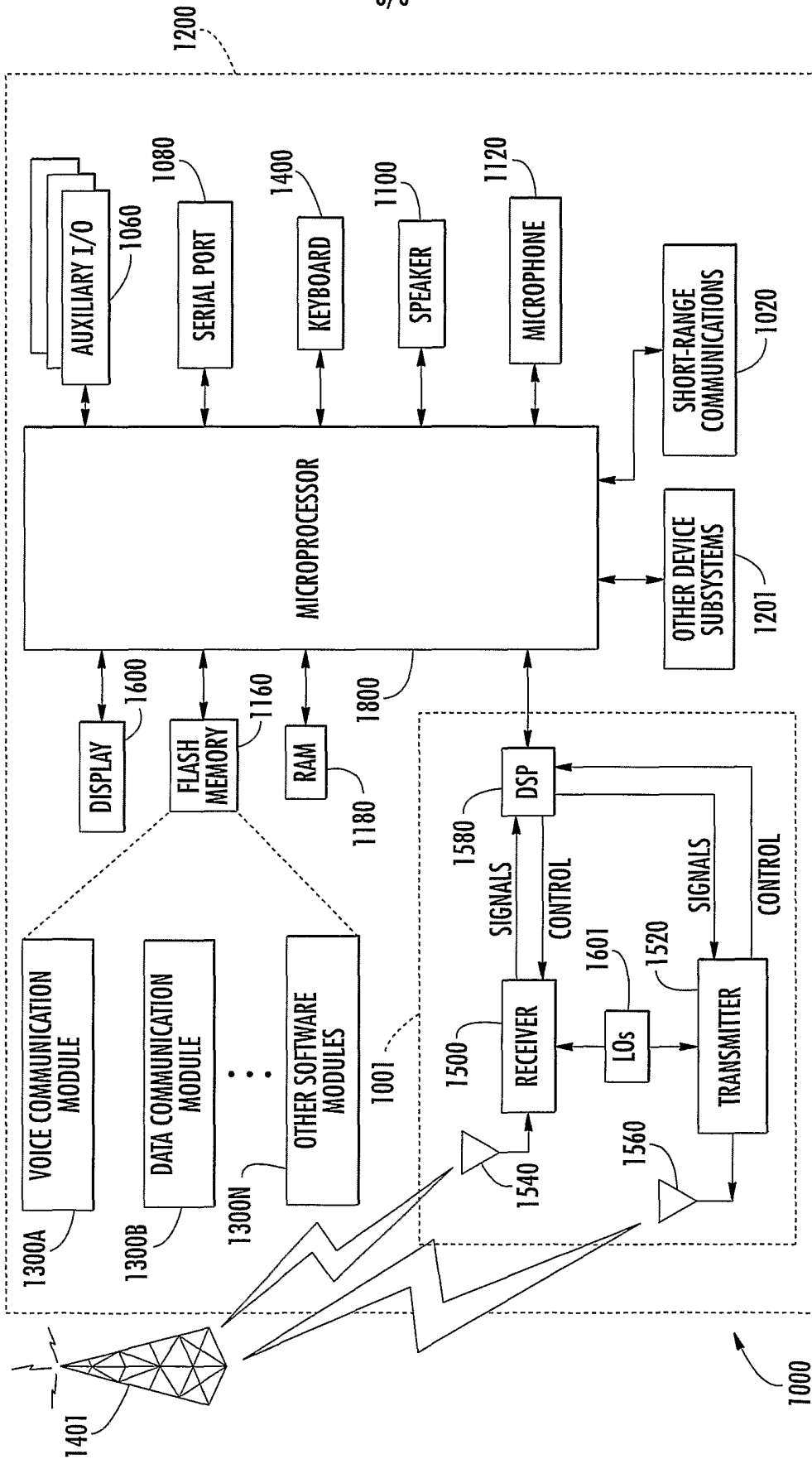

FIG. 10

**INTERNATIONAL SEARCH REPORT**

International application No.

PCT/US04/05768

**A. CLASSIFICATION OF SUBJECT MATTER**

IPC(7) : G06F17/30  
 US CL : 707/10, 707/2, 707/104.1, 707/201

According to International Patent Classification (IPC) or to both national classification and IPC

**B. FIELDS SEARCHED**

Minimum documentation searched (classification system followed by classification symbols)  
 U.S. : 707/10, 707/2, 707/104.1, 707/201

Documentation searched other than minimum documentation to the extent that such documents are included in the fields searched

Electronic data base consulted during the international search (name of data base and, where practicable, search terms used)  
 East Database 1.03 (USPAT; EPO; JPO; DERWENT; IBM TDB)

**C. DOCUMENTS CONSIDERED TO BE RELEVANT**

Category *	Citation of document, with indication, where appropriate, of the relevant passages	Relevant to claim No.
X,E	US 2004/0054719 A1 (DAIGLE et al.) 18 March 2004 (18.03.2004), page 3, paragraph 0046, page 5, paragraph 0058, page 6, paragraphs 0066-0072.	1-20
A,P	US Pub. 2003/0200267 A1 (GARRIGUES) 23 October 2003 (23.10.2003), figures 8-9, page 3, paragraphs 0037-0038, pages 7-8.	1-20
A	US 2003/0084107 A1 (COVEY) 01 May 2003 (01.05.2003), page 4, paragraphs 0043-0046, page 8.	1-20

Further documents are listed in the continuation of Box C.

See patent family annex.

* Special categories of cited documents:	"T"
"A" document defining the general state of the art which is not considered to be of particular relevance	later document published after the international filing date or priority date and not in conflict with the application but cited to understand the principle or theory underlying the invention
"E" earlier application or patent published on or after the international filing date	"X" document of particular relevance; the claimed invention cannot be considered novel or cannot be considered to involve an inventive step when the document is taken alone
"L" document which may throw doubts on priority claim(s) or which is cited to establish the publication date of another citation or other special reason (as specified)	"Y" document of particular relevance; the claimed invention cannot be considered to involve an inventive step when the document is combined with one or more other such documents, such combination being obvious to a person skilled in the art
"O" document referring to an oral disclosure, use, exhibition or other means	"&" document member of the same patent family
"P" document published prior to the international filing date but later than the priority date claimed	

Date of the actual completion of the international search  
 01 July 2004 (01.07.2004)

Date of mailing of the international search report  
**01 SEP 2004**

Name and mailing address of the ISA/US  
 Mail Stop PCT, Attn: ISA/US  
 Commissioner for Patents  
 P.O. Box 1450  
 Alexandria, Virginia 22313-1450  
 Facsimile No. (703) 305-3230

Authorized officer  
*For James R. Matthews*  
 Neveen Abel-Jalil  
 Telephone No. 703-305-8114