

(19) **DANMARK**

(10) **DK/EP 3584082 T3**



(12)

Oversættelse af
europæisk patentskrift

Patent- og
Varemærkestyrelsen

-
- (51) Int.Cl.: **B 41 F 35/02 (2006.01)** **B 08 B 1/00 (2006.01)** **B 08 B 3/02 (2006.01)**
B 41 F 35/04 (2006.01)
- (45) Oversættelsen bekendtgjort den: **2022-04-19**
- (80) Dato for Den Europæiske Patentmyndigheds bekendtgørelse om meddelelse af patentet: **2022-01-19**
- (86) Europæisk ansøgning nr.: **19180706.4**
- (86) Europæisk indleveringsdag: **2019-06-17**
- (87) Den europæiske ansøgnings publiceringsdag: **2019-12-25**
- (30) Prioritet: **2018-06-18 IT 201800006425**
- (84) Designerede stater: **AL AT BE BG CH CY CZ DE DK EE ES FI FR GB GR HR HU IE IS IT LI LT LU LV MC MK MT NL NO PL PT RO RS SE SI SK SM TR**
- (73) Patenthaver: **Simec Group S.r.l., Via Verga, 17, 21057 Olgiate Olona (VA), Italien**
- (72) Opfinder: **DELLA TORRE, Emilio Alberto, SIMEC GROUP S.R.L., Via Verga, 17, 21057 Olgiate Olona (VA), Italien**
- (74) Fuldmægtig i Danmark: **AWA Denmark A/S, Strandgade 56, 1401 København K, Danmark**
- (54) Benævnelse: **Indretning til rensning af cylindriske ruller, maskine omfattende indretningen og fremgangsmåde til rensning.**
- (56) Fremdragne publikationer:
CA-A1- 2 161 478
DE-A1-102015 005 535
GB-A- 1 328 512
JP-A- H06 262 758

DESCRIPTION

TECHNICAL FIELD

[0001] The present invention relates to a device for cleaning cylindrical rollers, with smooth or engraved surfaces, in particular rollers for printing machines, fluid transfer rollers, such as anilox rollers, cliché rollers, spreader rollers, finishers or laminators.

[0002] The invention also relates to a method for cleaning a roller.

BACKGROUND ART

[0003] Machines for printing web materials, such as, but not limited to, plies of tissue paper, are subject to frequent downtimes to allow cleaning of the rollers, as ply material tends to easily deposit small particles or fibers of material that, being in contact with the printing liquid (ink), soil or fill the small cells that transfer the ink.

[0004] These cells, which form the outer surfaces of the transport roller (also called anilox roller), must be kept clean and free from deposits, in order to best perform their function.

[0005] In fact, the liquid transferred, also becoming contaminated with debris from the web material to be printed, tends to stratify inside the cells used to transport the liquid, thereby reducing their capacity. This leads to a variation of the technical and/or visual features of the web material, for example due to a decrease in the density of the printing ink.

[0006] The frequent halts in the production line required to clean the rollers represent the main reason for loss of efficiency of the line.

[0007] Depending on the application field and type of printing machine, the characteristics of the rollers can vary, as can their structure. Therefore, machines have been designed that allow rapid removal of the rollers, in this way allowing them to be washed and cleaned off-line.

[0008] In other cases, situations can occur in which the removal of the roller would require very long disassembly, cleaning and reassembly times, for example in the field of rollers for processing corrugated cardboard.

[0009] Due to this variability, cleaning systems that operate off-line, i.e., systems in which the roller to be cleaned is disassembled from the production machine, as well as cleaning systems that are installed in-line, i.e., on the production machine, have been developed.

[0010] The cleaning systems currently available on the market can be summarized as follows:

manual systems with brushes, which allow the operator to clean the roller by rubbing it with the addition of chemical products. These systems do not guarantee the uniformity of the process and frequently do not comply with the current safety regulations;

Sodium bicarbonate systems, both in-line and off-line versions. These are efficient as regards the process, but very complex as regards management of the machine and of the product (*baking soda*) used, not always available with the ideal characteristics for the cleaning process;

laser systems applicable in-line or off-line. These systems are very costly and require the use of highly skilled personnel to avoid damaging the roller to be cleaned;

high-pressure water jet machines;

washing systems with dry ice;

washing systems using only chemical products. These can operate in-line and off-line. In the first case, the ink must be replaced. This system has the drawback that the cleaning liquid comes into contact with all the machine components and, being very aggressive, may damage some of the components. Moreover, the action of the cleaning liquid is not combined with a mechanical action. Therefore, in order to be effective, in addition to the use of an aggressive liquid, the washing operation also requires very long performance times.

[0011] In the case of off-line systems, the roller to be cleaned must be removed from the production line and machines used to clean it are very cumbersome.

[0012] Prior art cleaning systems are not sufficiently fast and reliable. In fact, known cleaning systems make use of consumables that are wasteful, polluting and have a high environmental impact (also for the operators in the immediate vicinity), or that do not guarantee satisfactory results in reasonable times.

[0013] Known cleaning systems, which use jets of cleaning liquid directed at a roller of a printing machine are disclosed in US7,428,868; US 6,957,607; WO1997000173, DE102015005535, CA2161478 and GB1328512. A cleaning system according to the preamble of claim 1 is disclosed in JP-6-262758 A.

[0014] These known cleaning systems have proved to be inefficient.

[0015] Therefore, there is the need to produce cleaning devices for cylindrical rollers that completely or partially solve one or more of the problems of the prior art devices.

OBJECTS AND SUMMARY OF THE INVENTION

[0016] The main object of the present invention is to provide a device that is fast, reliable and inexpensive, with regard to the cost of the system and the cost of the consumables.

[0017] Furthermore, it is aimed to obtain a cleaning device that can be easily installed, both in-line (i.e., on the machine) and off-line, in any working environment and without requiring particular safety equipment, as it has a small size, low weight, limited consumption of material and reduced cleaning cycle performance times. This means it can also be installed on existing machines with a quick replacement of existing devices, or added to plants without cleaning devices.

[0018] According to a first aspect, there is provided for this purpose a cleaning device according to claim 1. The cleaning device comprises a cleaning head with a cleaning chamber, in which a mechanical cleaning member is housed, and with which feeding members are associated for feeding a cleaning liquid into the cleaning chamber. With this layout, the mechanical member and the cleaning liquid dispensed by the feeding members work in combination inside the cleaning chamber to clean the cylindrical surface of the roller to be cleaned.

[0019] To clean rollers of considerable axial length with a device of limited dimensions, the cleaning head is provided with a translation movement in a direction parallel to the axis of the cylindrical roller. The combination of the rotation movement of the roller and the translation movement of the cleaning head allows the whole of the cylindrical surface of a roller, even with considerable radial and/or axial dimensions, to be washed efficiently in a small space.

[0020] In advantageous embodiments the cleaning head can be provided with a movement toward and away from the roller. The movement can be in an axial direction, i.e., can be such as to move the head away beyond an axial end of the roller. However, in preferred embodiments, the movement of the cleaning head toward or away from the lateral surface of the roller is orthogonal to the rotation axis of the roller, or in any case a movement that has at least one component orthogonal to the axis of the roller.

[0021] To obtain efficient washing, the cleaning head and, together with it, the mechanical cleaning member can be moved with respect to the lateral surface of the roller to be washed, maintaining the contact between mechanical cleaning member and surfaces of the roller. However, for more efficient washing and to reduce mechanical stresses on the components of the device, advantageously the mechanical cleaning member is provided with a movement inside the cleaning chamber.

[0022] In some embodiments, this movement can be a rotation movement. For example, the mechanical cleaning member can comprise a rotating brush, or preferably two counter-rotating brushes.

[0023] In currently preferred embodiments, the movement of the mechanical cleaning member is a reciprocating movement, preferably in a direction parallel to the rotation axis of the roller.

[0024] To delimit the cleaning chamber, the cleaning head comprises lateral sealing gaskets. These lateral sealing gaskets can have concave edges, with a curvature corresponding to, or slightly lower than that of the roller to be cleaned, so as to embrace the roller if necessary with a slight elastic deformation of the gaskets, to improve the lateral seal.

[0025] The lateral sealing gaskets are replaceable as a function of the diameter of the roller to be cleaned. For example, the lateral sealing gaskets can be housed in respective side elements that form lateral walls of the cleaning chamber. The side elements can be adapted to house the lateral sealing gaskets of variable dimensions, as a function of the variable diameter of said roller to be cleaned.

[0026] For efficient closing of the cleaning chamber, in some embodiments the cleaning head comprises an upper sealing blade and a lower sealing blade, adapted to delimit the cleaning chamber above and below. In advantageous embodiments the blades can be biased against the roller to be cleaned to improve the seal. For this purpose, the blades can be elastic, or can be associated with pressure members, such as piston-cylinder actuators, or springs or other elastic biasing members.

[0027] The mechanical cleaning member can comprise at least one brush.

[0028] According to a further aspect, the present invention also relates to a machine comprising a cylindrical roller to be cleaned and a device as defined above and as better described below with reference to examples of embodiment.

[0029] According to yet another aspect, the invention relates to a method for cleaning a cylindrical roller, with a device according to any of the above-mentioned configurations of the present invention, comprising the following steps:

moving, toward a lateral cylindrical surface of the cylindrical roller, a cleaning head as outlined above;

bringing the mechanical cleaning member into contact with the lateral cylindrical surface of the cylindrical roller to be cleaned, so as to substantially close the cleaning chamber from the front side;

moving the mechanical cleaning member into contact with the lateral surface of the cylindrical roller dispensing cleaning liquid into the cleaning chamber.

[0030] Further aspects and embodiments of the device and of the method according to the present invention are described hereunder with reference to the accompanying drawings and are defined in the appended claims, which form an integral part of the present description.

DETAILED DESCRIPTION OF EMBODIMENTS

[0031] The present invention will be better understood with reference to the accompanying figures, which show an application, but without limiting the scope of the present invention. In the accompanying drawings:

Fig.1 shows an overall view of an embodiment of the device of the present invention, installed on a printing machine;

Fig. 2 shows a partial sectional view of the cleaning head of the device obtained according to II-II of Fig. 3;

Fig.3A shows a front view of the cleaning head of Fig. 2;

Fig. 3B shows a lateral view of the cleaning head;

Fig.3C shows an axonometric view of the cleaning head;

Fig. 4 shows an axonometric view of the mechanical cleaning member;

Fig. 5 shows a lateral view of the mechanical cleaning member of Fig. 4;

Fig. 6 shows an axonometric view of two cleaning heads with the same function but with different dimensions,

Fig.7 shows an axonometric view of a further embodiment of the cleaning head, with lateral rinsing chambers.

DETAILED DESCRIPTION OF EMBODIMENTS

[0032] Hereunder the cleaning device is described in combination with an anilox roller of a printing machine. However, it must be understood that a cleaning device of the type described here can also advantageously be applied to clean other rollers affected by similar problems.

[0033] Fig. 1 shows an overall view of a printing machine generically indicated with 10, for example destined for printing and decorating a ply web material (not shown), which houses a cleaning device 20 of the invention. The cleaning device 20 is essentially composed of two parts, indicated respectively with 30 (cleaning head) and 40 (movement assembly).

[0034] The cleaning head 30 acts, in the example illustrated, on an anilox roller 50, which has on the surface a coating made of a hard material, for example a ceramic material, engraved with small cells, which transport the printing liquid, typically an ink. These cells (not shown) can become at least partially clogged with debris consisting of particles of paper and ink. When this occurs the anilox roller 50 becomes unusable and requires a cleaning operation. For this

purpose, the cleaning head 30 is brought into close proximity of the anilox roller 50 and subsequently made to translate in a direction parallel to the axis of the roller 50, as better described below.

[0035] With reference to Figs. 3A, 3B, 3C, the cleaning head 30 comprises various components, including a mechanical cleaning member 60, which can be a brush. The cleaning head further comprises a pair of nozzles 70 for spraying a cleaning liquid, upper and lower sealing blades 80 and lateral sealing gaskets 90. When the cleaning head 30 is in the operating position and coacts with the anilox roller 50, the assembly made up of the upper and lower blades 80 and of the sealing gaskets 90 forms, together with the cylindrical surface of the roller 50, a fluid tight cleaning chamber 110.

[0036] In advantageous embodiments, the blades 80 are adjustable and held with pressure against the roller 50 to be cleaned through the use of compression members 100 (Figs.3B, 3C) exemplified here in the form of springs, which allow fluid tightness in the upper and lower part of the cleaning chamber 110 also when there is a variation in the diameter of the roller 50 to be cleaned, as the blades 80 are always in contact and with a certain pressure against the roller 50.

[0037] The sealing gaskets 90 are supported by respective side elements 120 that, in the same way as the blades 80, can accommodate gaskets 90 of different dimensions, or rather with a concave profile 130 adapted to the variable diameter of the roller 50. This means that, with the same cleaning head 30 and the same side elements 120 it is possible to clean rollers 50 with various diameters, as the cleaning chamber 110 will in any case remain exempt from seepages or leakages of liquid, due to the spring adaptability of the blades 80 and to simple replacement of the sealing gaskets 90.

[0038] As the variation of the diameter of the rollers 50 to be cleaned ranges from around 150 mm to around 300 mm, in some embodiments the side elements 120, and with these elements the whole cleaning head 30, can cover roughly half of the range indicated above. This means that it will be possible, for example, to have a first cleaning head 30, and respective side elements 120, to install on the cleaning device 20 for rollers 50 of diameter comprised between around 150 mm and around 220 mm, and a second different (larger) cleaning head 30 with side elements 120 of a size which is larger than previous ones, for rollers 50 with a diameter comprised between around 220 mm and around 300 mm. Fig.6 shows, in an axonometric view, compared with each other, two cleaning heads 30 of different dimensions to cover the whole range of diameters of the roller 50 to be cleaned.

[0039] In this way with two different cleaning heads 30, with dimensions different from one another, it will be possible to perform cleaning of rollers 50 with any diameter comprised between around 150 mm and around 300 mm. In fact, it will be sufficient to install on the cleaning device 20 the head 30 with larger or smaller side elements 120 depending upon the diameter of the roller 50 to be cleaned.

[0040] In the case of a small variation in the diameter of the roller 50 it will not be necessary to change the side elements 120, but it will be sufficient to replace the sealing gaskets 90 corresponding to the new diameter of the roller 50 to be cleaned.

[0041] As mentioned above, a mechanical cleaning member, in this case a brush 60, is arranged inside the cleaning chamber 110. Advantageously, the brush 60 is translated with a reciprocating movement in a direction parallel to the axis of the roller 50. In this way, the combined action of the liquid injected at low pressure by the nozzles 70 and the reciprocating movement of the brush 60 allows fast, efficient and low cost cleaning of the cylindrical surface of the roller 50. In the illustrated example, the movement of the brush or other mechanical cleaning member 60 is obtained with an actuator, for example a pneumatic motor 61, and the motion is transmitted, for example, through a cam and eccentric, indicated schematically with 62, although it would also be possible to use other systems known in the art.

[0042] In some embodiments, the brush 60 is advantageously formed of two parts 140 (Fig. 4) extending in transverse direction (parallel to the axis of the roller 50), so as to leave a channel 180 between the two parts 140. In this way, a small amount of cleaning liquid coming from the nozzles 70 is maintained in direct contact both with the roller 50 and with the bristles forming the two parts 140.

[0043] The two parts 140 of the brush 60 advantageously have a dovetail shape (see in particular Figs.2 and 5), so as to bring the bristles of the two parts 140 as close as possible to the roller 50 to be cleaned, and to create an obligatory path for the cleaning liquid (maximizing the contact time of the cleaning liquid on the roller and consequently its removal efficiency).

[0044] More in particular, as shown in Fig. 5, each of the two parts 140 of the brush 60 has a surface (for example formed by the tips of the bristles that make up each part 140 of the brush 60) that form an angle α with a vertical plane. The angle α can for example be from around 5° to around 20° , preferably from around 10° to around 15° , preferably of around 12° . The aforesaid inclined surfaces of the parts 140 of the brush 60 are inclined in opposite directions, so as to be arranged, in substance, on the two sides of a "V" with opening $(180-2\alpha)$ degrees, so that the two parts 140 of the brush 60 embrace the cylindrical surface of the roller 50 as much as possible.

[0045] The brush 60 can be provided with bristles of different thickness and material, for example the bristles can have dimensions comprised between 0.05 and 0.5 mm, advantageously between 0.1 and 0.2 mm and be made of filaments of brass, steel, plastic or animal material. The aforesaid parameters and materials can vary as a function of the shape and of the material of the surfaces to be cleaned, and of the pressure required and expected useful life of the bristles. It would also be possible to use brushes 60 provided with mixed bristles, i.e. made of different materials, for example harder and softer bristles, which can have various arrangements. For example, clumps or groups of bristles of a first type can be arranged alternated with clumps or groups of bristles of a second type.

[0046] To be able to adapt to rollers 50 to be cleaned with different diameters, the brush 60 can be supported so that it also slides in a direction (indicated with Z in Fig. 2) toward the roller 50 to be cleaned. This forward movement according to the direction Z has the dual purpose of offsetting any differences in the diameter of the roller 50 to be cleaned, and of adjusting the pressure exerted by the bristles 140 on the roller 50. This latter characteristic can also be exploited to offset partial wear of the bristles, so that the effectiveness of the action of the brush 60 remains more or less constant, extending the useful life of the brush 60. The number 71 (Fig.2) indicates a fixing and adjustment column, along which the cleaning head 30 can translate to move toward the axis of the roller 50.

[0047] For the same reason, the cleaning head 30 can be supported by an arm (not shown) adjustable in length, so that the seal of the blades 80 and of the sealing gaskets 90 is guaranteed against seepage of cleaning liquid and of any residues removed from the roller 50.

[0048] As mentioned initially, the cleaning head 30 (see. Fig. 1) is mounted on a movement assembly 40 that controls translation of the cleaning head 30 in a direction parallel to the axis of the roller 50. The movement is indicated by the double arrow X in Fig.1 and is advantageously a two-way movement, so that the cleaning head 30 can translate in the two directions to act on the whole cylindrical surface of the roller 50. The translation movement can be imparted to the head 30 by any known movement system. In the case shown, a rack and pinion system is used, but it would be possible to use other known systems, for example with belt and pulley, with gears or with recirculating ball screws

[0049] In some embodiments, one or more holes 160 (Fig.2) are arranged in the lower part of the cleaning chamber 110, connected to which are pipes 165 (Fig.3A) for collecting and recovering the cleaning liquid and any debris detached from the roller 50. Evacuation of the remaining cleaning liquid and of any debris can take place through gravity or vacuum, both induced from the outside, or through slight overpressure that is created in the cleaning chamber 110.

[0050] The lateral sealing gaskets 90 can be housed in respective seats, obtained in negative in the side elements 120, so that the gaskets 90 with concavity 130 with different diameters (to operate on rollers 50 with different diameters), can in any case be installed on the same side elements 120. This makes the cleaning head 30, and hence the whole cleaning device, extremely versatile. Moreover, the shape of the gaskets 90 is such that they are very easy to replace without the aid of particular tools.

[0051] In fact, as described above, simply by replacing the sealing gaskets 90, it is possible to obtain effective cleaning of rollers 50 with very variable diameters, for example in a range comprised between around 150 and around 220 mm, or between around 220 and around 300 mm. Advantageously, also the blades 80 contribute to this flexibility of the device, as for the aforesaid range of diameters of the roller 50 to be cleaned, the simple action of the springs 100 (Fig.3A) is sufficient to guarantee the seal in the direction of rotation of the roller 50, both in the upper part and in the lower part of the cleaning chamber 110.

[0052] The lateral sealing gaskets 90 can be made of different materials, provided the material has sufficient resistance to sliding friction and does not overheat. A particularly suitable material has proven to be "EVA" closed cell expanded polyethylene, with a density comprised between 50 and 120 kg/m³. However, it would also be possible to use other materials with similar or improved characteristics with respect thereto.

[0053] The device described above functions as follows.

[0054] The cleaning head 30 of the device 20 is brought into close proximity of the roller 50 to be cleaned. A slight forward movement of the head 30 in the direction of the roller 50 causes closing of the cleaning chamber 110, delimited laterally by the sealing gaskets 90, which can have the concave front part 130 with a radius of curvature equal to or slightly smaller than the radius of the roller 50. The sealing gaskets 90 can be moved toward the roller 50 with a slight pressure against the cylindrical lateral surface of said roller 50. The cleaning chamber 110 is delimited on top and on the bottom by the blades 80 held with pressure against the roller 50 by the springs 100 or another suitable member, for example another elastic member, a piston-cylinder actuator or other suitable means. Thanks to the particular structure of the blades 80 and of the gaskets 90, the cleaning chamber 110 remains sealingly closed regardless of the direction of rotation of the roller 50. The cylindrical surface of the roller 50 completes the front closing of the cleaning chamber 110, while a wall 31 (Fig.2) of the cleaning head 30 closes it at the rear.

[0055] After the forward movement and sealing of the cleaning chamber 110, the brush 60, with its bristles 140 coming into contact with the surfaces of the roller 50 to be cleaned through the forward movement of the head 30 toward the roller 50, starts to move inside the cleaning chamber 110 in a direction transverse to the roller, i.e., parallel to the axis thereof, so as to cause the bristles of the brush 60 or other mechanical cleaning member to rub against the surfaces of the roller 50 to be cleaned.

[0056] Simultaneously, the nozzles 70 inject cleaning liquid, which can consist of water, a solution of water and detergent, or another liquid product with a cleansing action. The combined action of rubbing of the bristles of the brush 60 and of the cleaning liquid, ensures that the portion of surfaces of the roller 50 to be cleaned involved and circumscribed by the cleaning chamber 110 is easily cleaned. The particles of paper, ink, or any other processing residues that have deposited in the cells of the roller 50 are easily removed. The used cleaning liquid flows downward, thus drawing the debris toward the hole or holes 160, from where it is removed through the pipe or pipes 165. The supply and removal of the cleaning liquid can take place discontinuously or preferably continuously.

[0057] In particular cases, for example in case of particularly stubborn dirt, it is possible to use a heated cleaning liquid, so that it is even more effective on the dirt to be removed. The cleaning liquid can be water or any cleaning product, pure or diluted, and can be heated, for example, to a temperature comprised between 25°C and 50°C, preferably between 30 °C and

45°C.

[0058] To perform cleaning of the whole cylindrical surface of the roller 50 it is sufficient to rotate the roller 50 to cover the entire circumference thereof. Through a simple translation of the cleaning head 30 in the direction X (Fig.1), parallel to the axis of the roller 50, it is possible to gradually clean the various annular portions of the roller from one end to the other. By providing an operation with continuous movements, i.e. with continuous rotation of the roller 50 and continuous translation of the cleaning head 30, fast and efficient cleaning can be obtained with a simple device, which requires a small operating space around the roller 50 to be cleaned.

[0059] According to further embodiments, the cleaning head 30 can be provided with means to prevent or limit the lateral seepage of cleaning liquid during use. For example, Fig. 7 shows a configuration of cleaning head 30 with double containment chambers.

[0060] The same numbers indicate the same or equivalent parts to those already described with reference to the preceding figures, which will not be described again. The main difference between the cleaning head 30 of Fig.7 and those illustrated in the preceding figures substantially consists in that a further lateral sealing gasket 91, adjacent to the respective sealing gasket 90 described above, is added laterally on the left and right sides of the cleaning head 30.

[0061] An empty chamber 92 is formed between the two lateral gaskets 90, 91 of each side of the cleaning head 30. Nozzles 93 for feeding a rinsing liquid, for example water, flow into said chamber 92.

[0062] With this configuration of the cleaning head 30 it is possible to manage both the cleaning step of the roller 50 by means of liquid detergents, and the subsequent rinsing step.

[0063] It would also be possible to add, if necessary, in a further lateral chamber for each side, a suction system of the cleaning liquid and/or of the rinsing liquid.

[0064] Summarizing, the advantages that can be obtained with embodiments of the device according to the present invention are:

- the cleaning process can combine the action of any chemical detergent with the action of a mechanical member;
- with the same process effectiveness, the system is less expensive than existing systems;
- it is possible to process any engraving profile and up to very high line counts (600 lines/cm);
- there are no dispersions of cleaning product;
- the amount of cleaning product used is very small;
- with the same process effectiveness, the system is faster than existing systems;
- it can be used in any working environment without the operator requiring particular

- protective and/or safety equipment;
- it is very simple to use and the operator does not require to have any particular training.

[0065] It is understood that the description above merely represents an example of the invention, and that this invention can vary in form and arrangement without departing from the scope of protection of the appended claims.

REFERENCES CITED IN THE DESCRIPTION

Cited references

This list of references cited by the applicant is for the reader's convenience only. It does not form part of the European patent document. Even though great care has been taken in compiling the references, errors or omissions cannot be excluded and the EPO disclaims all liability in this regard.

Patent documents cited in the description

- [US7428868B](#) [0013]
- [US6957607B](#) [0013]
- [WO1997000173A](#) [0013]
- [DE102015005535](#) [0013]
- [CA2161478](#) [0013]
- [GB1328512A](#) [0013]
- [JP6262758A](#) [0013]

P A T E N T K R A V

1. Renseindretning (20) til rensning af en cylindrisk rulle (50), omfattende et renehoved (30) med et renekammer (110), i hvilket der er anbragt et mekanisk reneelement (60), og til hvilket der er tilknyttet tilførselselementer (70) til at tilføre en renevæske ind i renekammeret (110);
- 5 hvor det mekaniske reneelement (60) og renevæsken, som dispenseres af tilførselselementerne (70), arbejder i kombination inde i renekammeret (110);
- hvor renehovedet (30) er tilvejebragt med en translationsbevægelse i en retning parallelt med akse af den cylindriske rulle (50);
- 10 k e n d e t e g n e t ved, at renehovedet (30) omfatter laterale tætningspakninger (90) af renekammeret (110); hvor de laterale tætningspakninger (90) er udskiftelige som en funktion af diameteren af den cylindriske rulle (50), som skal renses.
2. Indretning ifølge krav 1, hvor renehovedet (30) er tilvejebragt med en bevægelse mod og væk fra den cylindriske rulle (50), med i det mindste en komponent som er vinkelret på akse af den cylindriske rulle (50).
- 15 3. Indretning ifølge krav 1 eller 2, hvor det mekaniske reneelement (60) er tilvejebragt med en bevægelse inde i renekammeret (110).
4. Indretning ifølge krav 3, hvor bevægelsen af det mekaniske reneelement (60) inde i renekammeret
- 20 (110) er en frem- og tilbagegående bevægelse.
5. Indretning ifølge krav 3 eller 4, hvor bevægelsen af det mekaniske reneelement (60) inde i renekammeret (110) er en frem- og tilbagegående bevægelse ifølge en retning parallel med akse af den cylindriske rulle (50).
- 25 6. Indretning ifølge ét eller flere af de foregående krav, hvor det mekaniske reneelement (60) er tilvejebragt med en bevægelse, i forhold til renekammeret (110), mod eller væk fra den cylindriske rulle (50).
7. Indretning ifølge ét eller flere af de foregående krav, hvor de laterale tætningspakninger (90) er elastisk
- 30 eftergivende for at tilpasse sig den laterale overflade af den cylindriske rulle (50) som skal renses.
8. Indretning ifølge ét eller flere af de foregående krav, hvor de laterale tætningspakninger (90) er anbragt i respektive sideelementer (120), hvilke sideelementer (120) er indrettet til at rumme laterale tætningspakninger (90) af variable dimensioner, som en funktion af den variable diameter af den cylindriske rulle (50), som skal
- 35 renses.
9. Indretning ifølge krav 8, hvor sideelementerne (120) er indrettet til at rumme laterale tætningspakninger (90), som kan udskiftes for at dække en række af diametre af den cylindriske rulle (50) som skal renses, omfattende mellem 150 og 220 mm, eller mellem 220 og 300 mm.

10. Indretning ifølge ét eller flere af de foregående krav, hvor renehovedet (30) omfatter et øvre tætningsblad (80) og et nedre tætningsblad (80), som er indrettet til at afgrænse resekammeret (110), hvilke tætningsblade (80) holdes ved tryk på den cylindriske rulle (50), som skal renses gennem trykelementer (100).

5

11. Indretning ifølge krav 10, når afhængig i det mindste af krav 8, hvor det øvre tætningsblad (80) og det nedre tætningsblad (80) er understøttet af sideelementerne (120).

10 12. Indretning ifølge krav 10, hvor resekammeret (110) er gjort fluid-tæt gennem kombinationen af de laterale tætningspakninger (90) og af tætningsbladene (80) i samarbejde med den laterale overflade af den cylindriske rulle (50), som skal renses.

15 13. Indretning ifølge ét eller flere af de foregående krav, hvor renehovedet (30) omfatter laterale renseskeindeslutningskamre (92), som er åbne mod den laterale overflade af den cylindriske rulle (50), som skal renses.

14. Indretning ifølge krav 13, hvor de laterale renseskeindeslutningskamre (92) er arrangeret langs eller inde i de laterale tætningspakninger (90).

20 15. Indretning ifølge krav 14, hvor dyser (93) til tilførsel af en skyllevæske åbner ind i de laterale renseskeindeslutningskamre (92).

16. Indretning ifølge ét eller flere af de foregående krav, hvor det mekaniske reseelement (60) omfatter i det mindste en børste.

25

17. Indretning ifølge ét eller flere af de afhængige krav, hvor det mekaniske reseelement (60) er opdelt i mindst to dele (140), som er overlejret og adskilt langs en kanal (180) parallelt med den cylindriske rulle (50), som skal renses.

30 18. Indretning ifølge ét eller flere af de foregående krav, hvor det mekaniske reseelement (60) har to aktive overflader, som er indrettet til at virke på den cylindriske rulle (50), som skal renses, og som er indbyrdes tilbøjelige til at danne en V-formet overflade med toppunktet orienteret mod indersiden af resekammeret (110).

35 19. Maskine omfattende en cylindrisk rulle (50), som skal renses, og en indretning ifølge ét eller flere af de foregående krav.

20. Fremgangsmåde til rensning af en cylindrisk rulle (50) med en indretning ifølge ét eller flere af de foregående krav, hvilken fremgangsmåde omfatter de følgende trin:

- at bevæge renehovedet (30) mod en lateral cylindrisk overflade af den cylindriske rulle (50);
- at bringe det mekaniske reneelement (60) i kontakt med den laterale cylindriske overflade af den cylindriske rulle (50), som skal renses;
- at bevæge det mekaniske reneelement (60) i forhold til den laterale overflade af den cylindriske rulle (50) og i kontakt dermed, og dispensere renevæske ind i resekammeret (110).

5

21. Fremgangsmåde ifølge krav 20, hvor trinnet med at bevæge det mekaniske reneelement (60) i kontakt med den laterale overflade af den cylindriske rulle (50) omfatter trinnet at forskyde det mekaniske reneelement (60) med skiftende bevægelse i overensstemmelse med en retning parallel med akse af den cylindriske rulle (50).

10

22. Fremgangsmåde ifølge krav 20 eller 21, omfattende trinnet at rotere den cylindriske rulle (50) om sin akse, mens det mekaniske reneelement (60) virker på den laterale overflade af den cylindriske rulle (50).

15

23. Fremgangsmåden ifølge kravene 20, 21 eller 22, yderligere omfattende trinnet at gradvist forskyde renehovedet (30) langs akse af den cylindriske rulle (50) for at rense hele den laterale overflade af den cylindriske rulle (50).

DRAWINGS

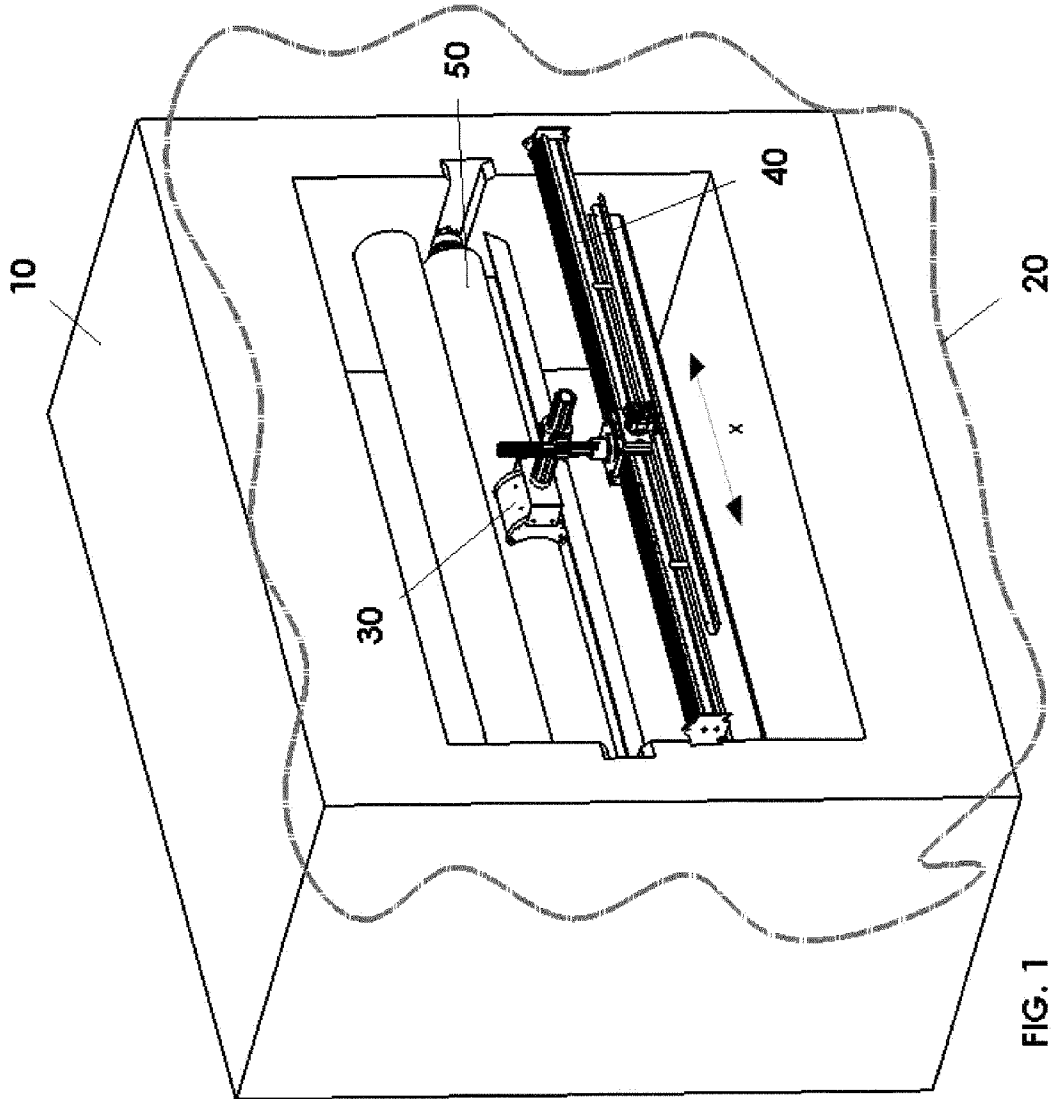

FIG. 1

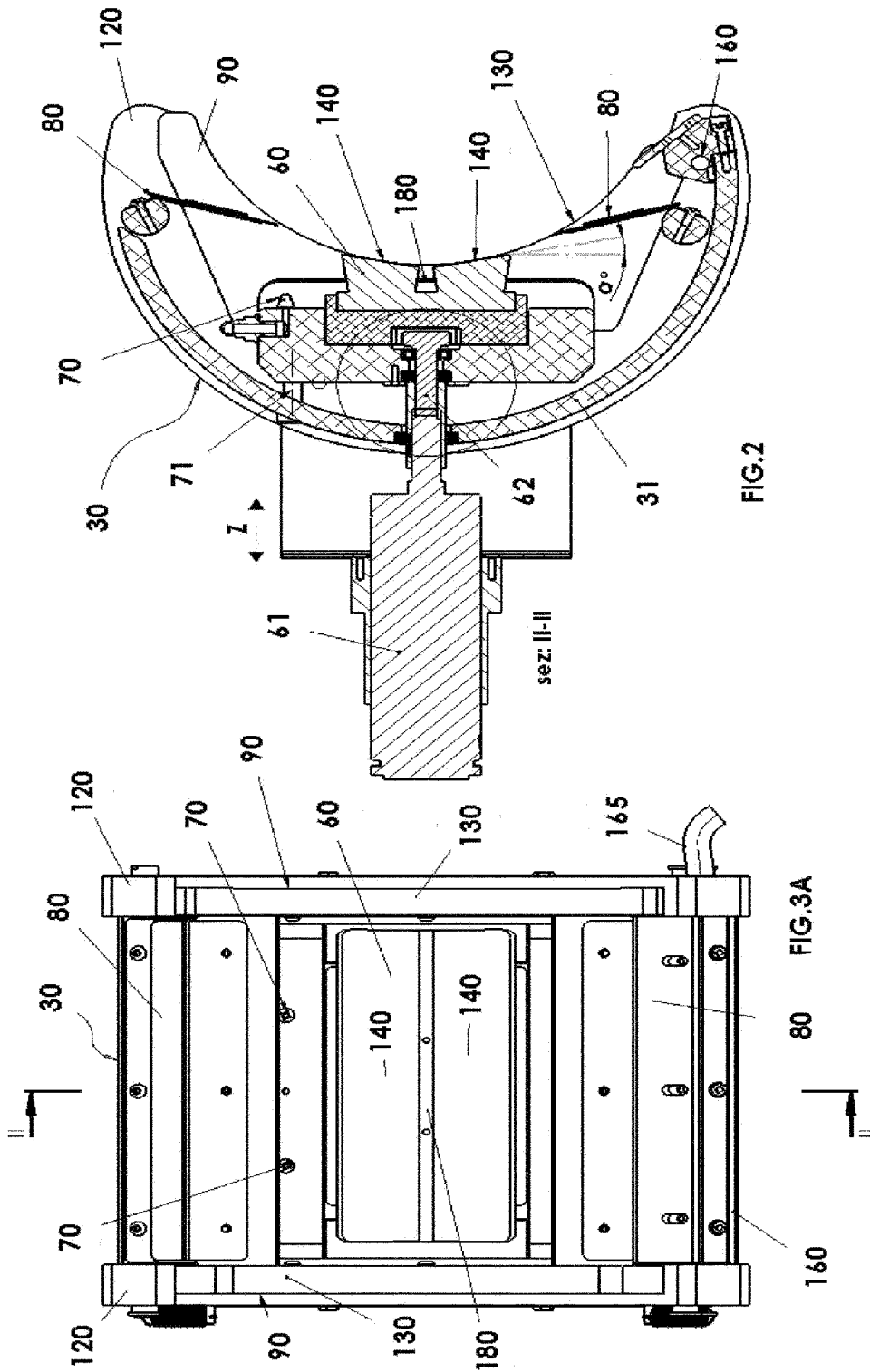

FIG.2

FIG.3A

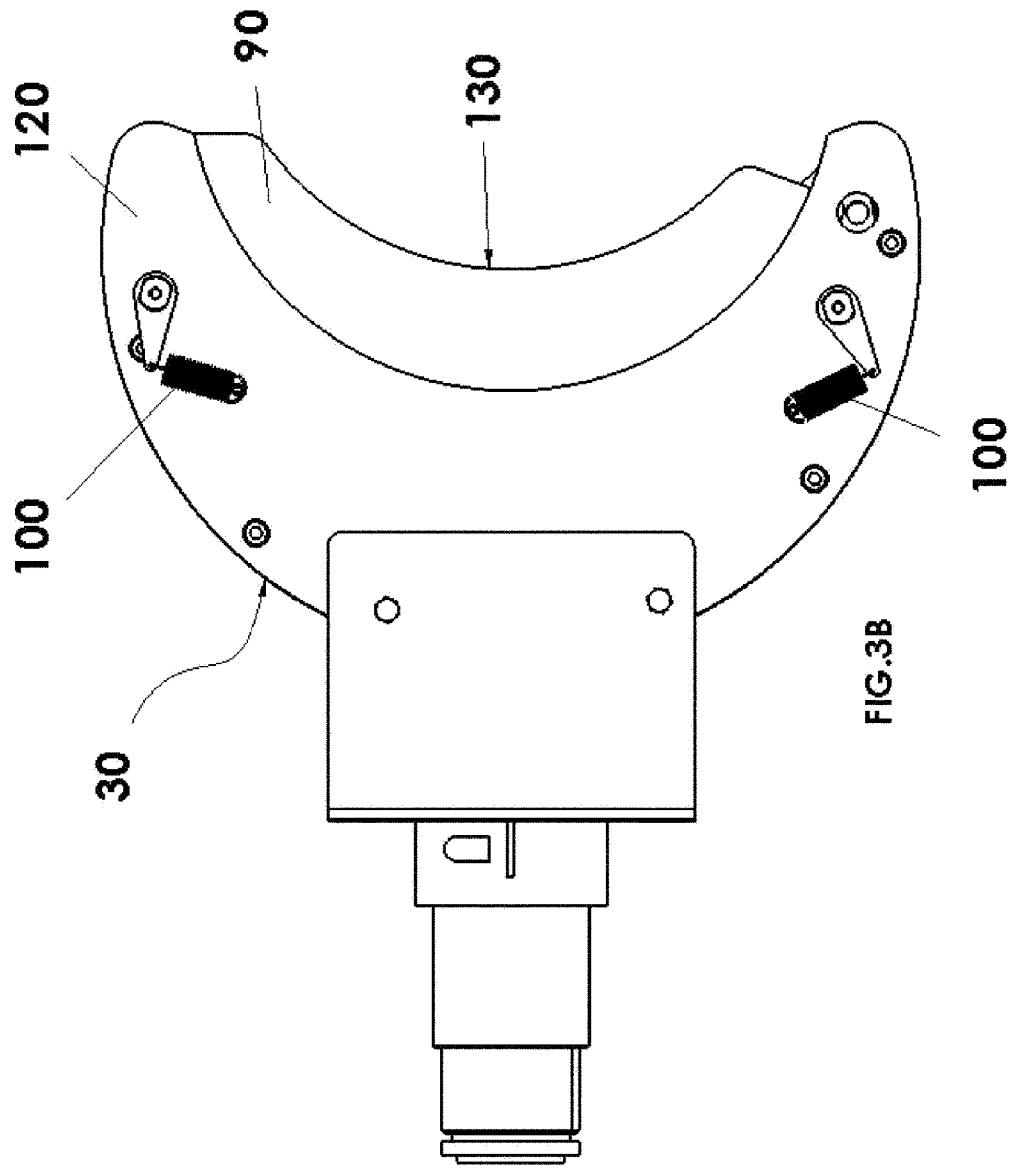
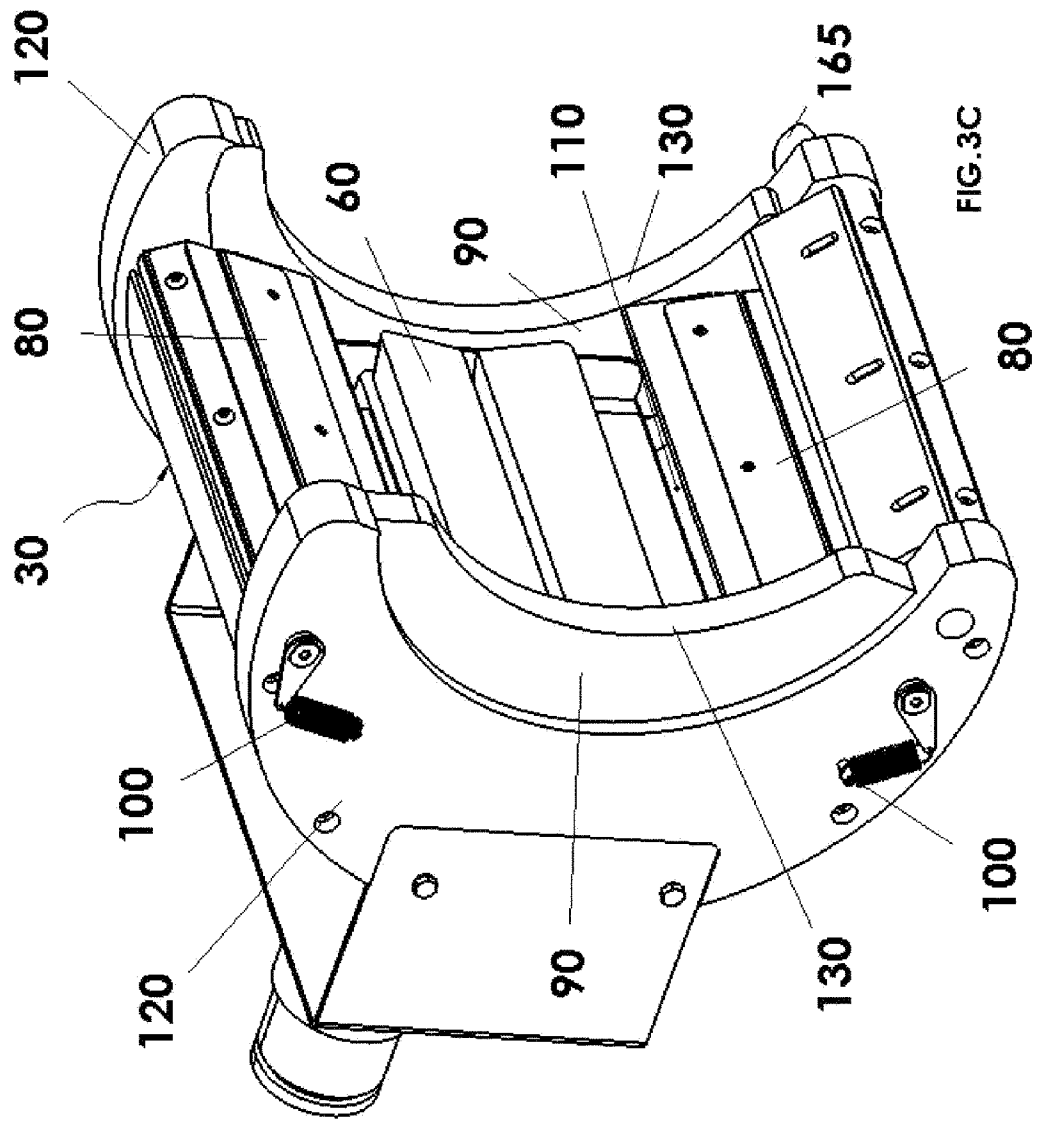
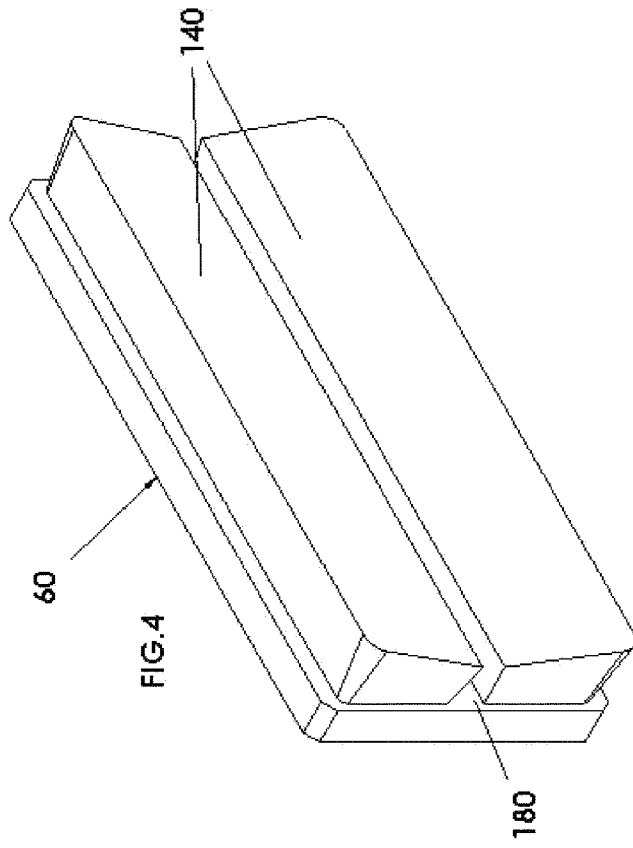

FIG. 3B





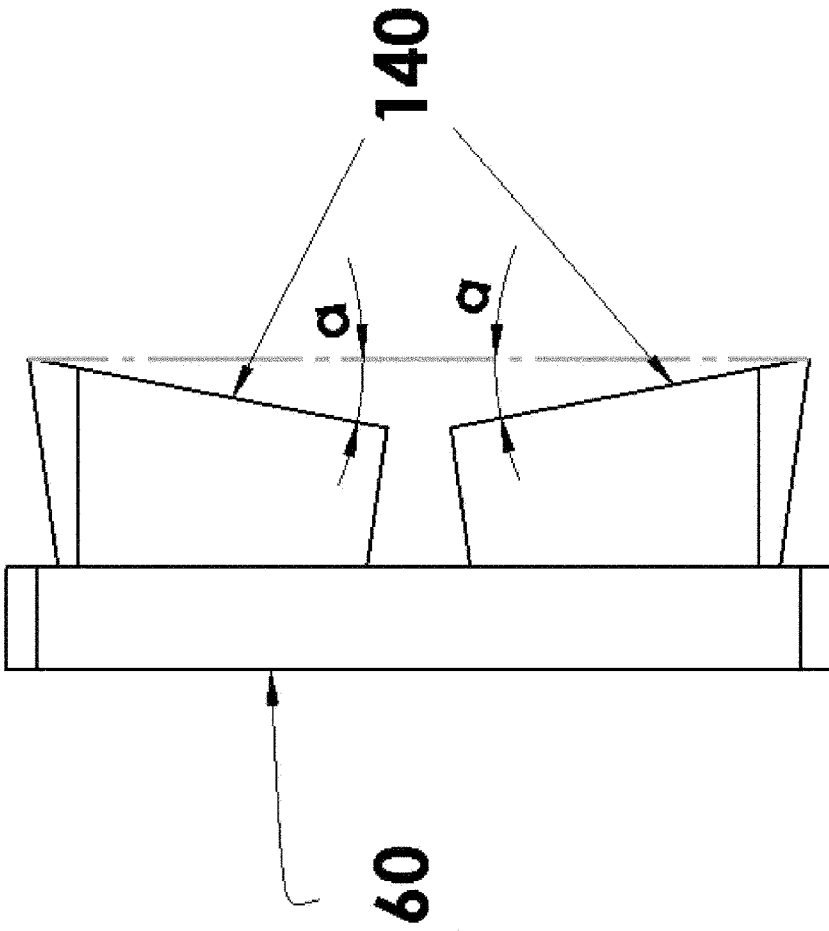

FIG.5

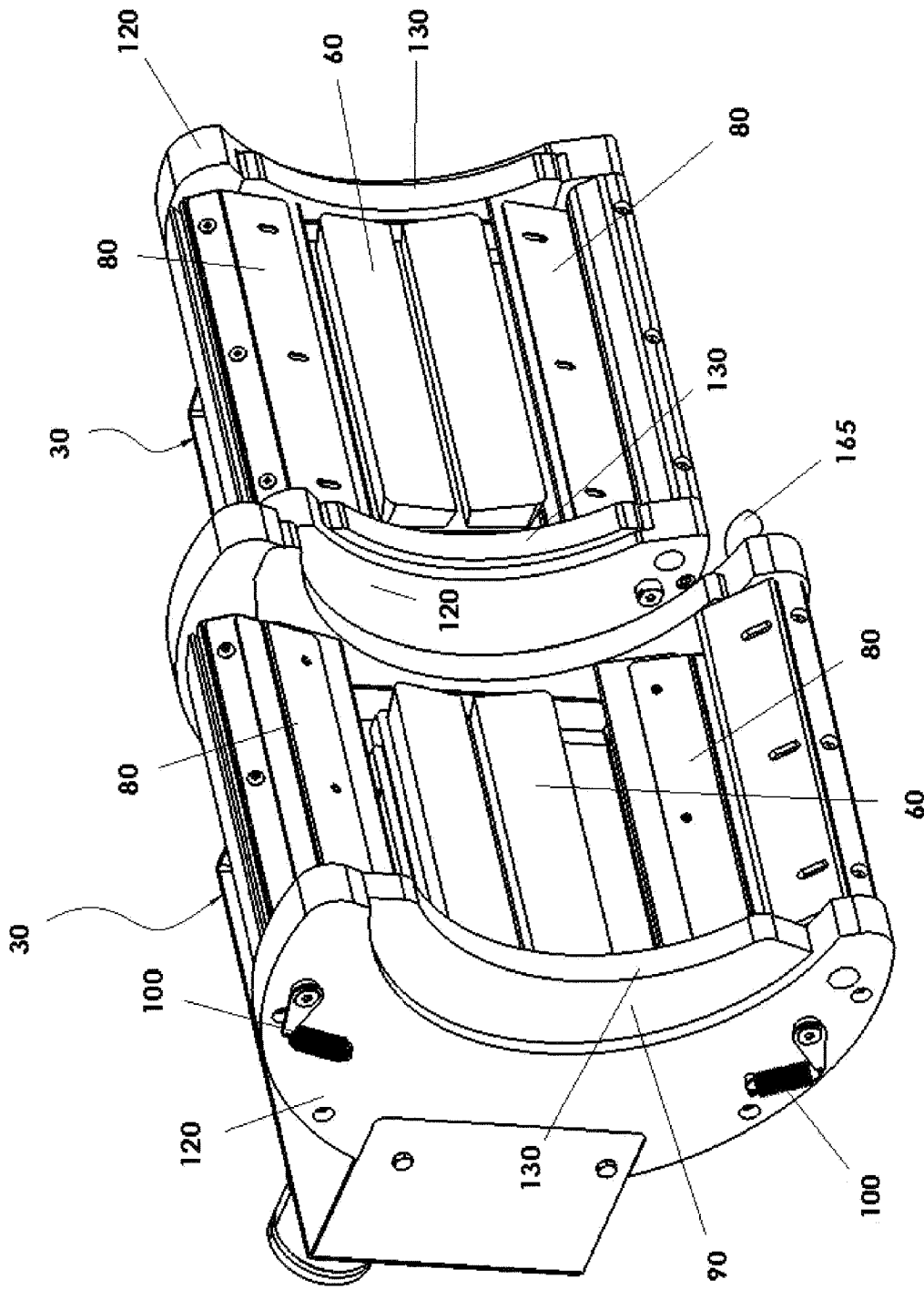

FIG. 6

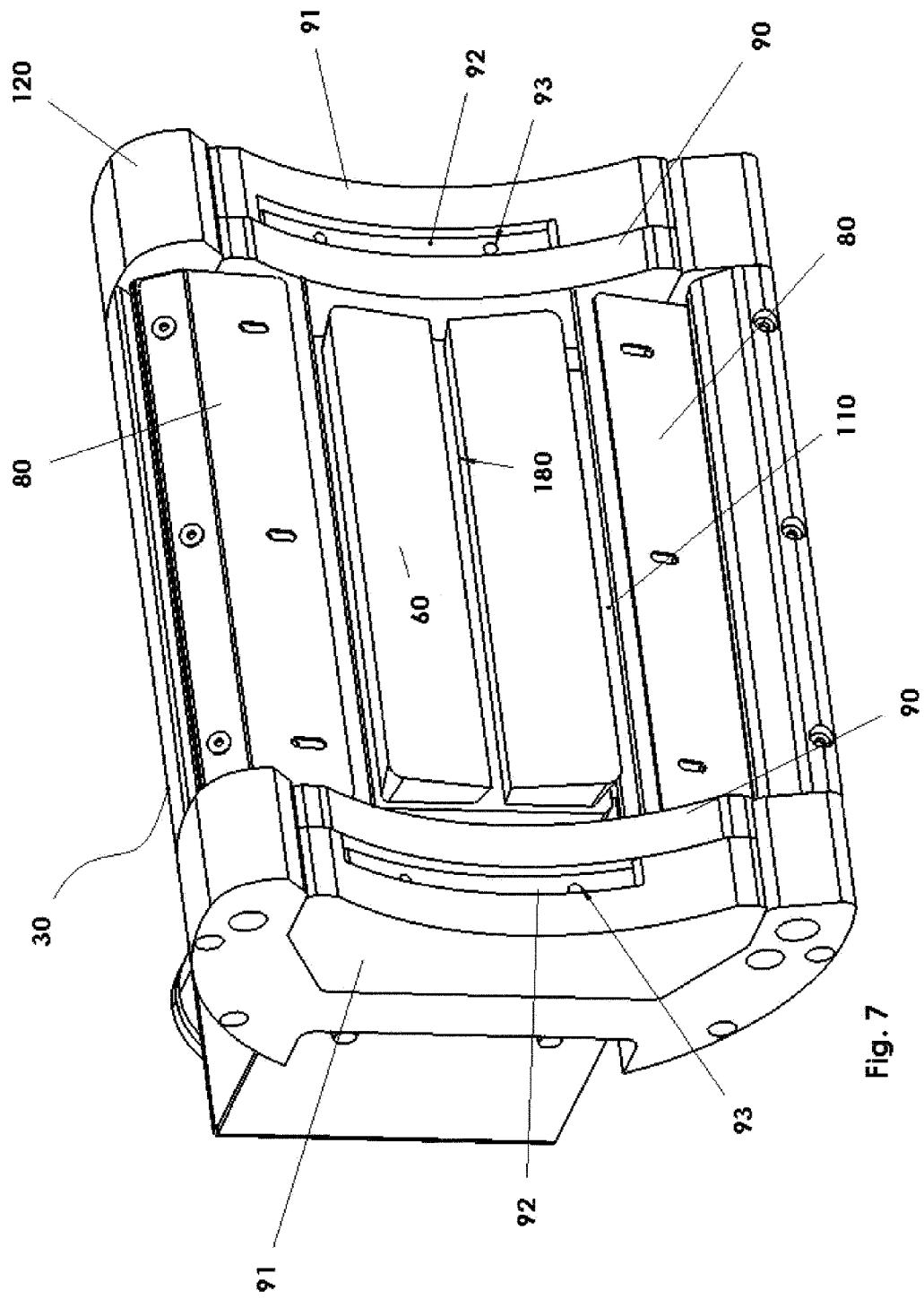

Fig. 7