



(51) International Patent Classification:

*H04L 5/00* (2006.01)      *H04W 74/08* (2009.01)  
*H04W 56/00* (2009.01)      *H04B 7/185* (2006.01)  
*H04W 74/00* (2009.01)      *H04B 7/26* (2006.01)

(21) International Application Number:

PCT/US2020/015267

(22) International Filing Date:

27 January 2020 (27.01.2020)

(25) Filing Language:

English

(26) Publication Language:

English

(30) Priority Data:

62/796,976      25 January 2019 (25.01.2019)      US

(71) Applicant: **APPLE INC.** [US/US]; One Apple Park Way, Cupertino, California 95014 (US).

(72) Inventor: **NARASIMHA, Murali**; c/o APPLE INC., One Apple Park Way, Cupertino, California 95014 (US).

(74) Agent: **HELVEY, Jeffrey T.** et al.; STERNE, KESSLER, GOLDSTEIN & FOX P.L.L.C, 1100 New York Avenue, NW, Washington, District of Columbia 20005 (US).

(81) Designated States (*unless otherwise indicated, for every kind of national protection available*): AE, AG, AL, AM, AO, AT, AU, AZ, BA, BB, BG, BH, BN, BR, BW, BY, BZ, CA, CH, CL, CN, CO, CR, CU, CZ, DE, DJ, DK, DM, DO,

DZ, EC, EE, EG, ES, FI, GB, GD, GE, GH, GM, GT, HN, HR, HU, ID, IL, IN, IR, IS, JO, JP, KE, KG, KH, KN, KP, KR, KW, KZ, LA, LC, LK, LR, LS, LU, LY, MA, MD, ME, MG, MK, MN, MW, MX, MY, MZ, NA, NG, NI, NO, NZ, OM, PA, PE, PG, PH, PL, PT, QA, RO, RS, RU, RW, SA, SC, SD, SE, SG, SK, SL, ST, SV, SY, TH, TJ, TM, TN, TR, TT, TZ, UA, UG, US, UZ, VC, VN, WS, ZA, ZM, ZW.

(84) Designated States (*unless otherwise indicated, for every kind of regional protection available*): ARIPO (BW, GH, GM, KE, LR, LS, MW, MZ, NA, RW, SD, SL, ST, SZ, TZ, UG, ZM, ZW), Eurasian (AM, AZ, BY, KG, KZ, RU, TJ, TM), European (AL, AT, BE, BG, CH, CY, CZ, DE, DK, EE, ES, FI, FR, GB, GR, HR, HU, IE, IS, IT, LT, LU, LV, MC, MK, MT, NL, NO, PL, PT, RO, RS, SE, SI, SK, SM, TR), OAPI (BF, BJ, CF, CG, CI, CM, GA, GN, GQ, GW, KM, ML, MR, NE, SN, TD, TG).

Published:

— with international search report (Art. 21(3))

(54) Title: RANDOM ACCESS RECEPTION AND MESSAGE 3 TRANSMISSION FOR NEW RADIO (NR) BASED SATELLITE COMMUNICATION

(57) Abstract: Embodiments disclosed herein include methods and apparatuses that enable the UE to transmit message 3 in an NTN network. A gNB can include, a time duration indicating the time at which the UE should transmit message 3. The network can ensure that the UE has adequate time to apply the timing advance, assemble and transmit message 3. The UE can compute time of UL grant application based on a timing advance. The time of application of the UL grant can be determined by the UE and by the gNB according to a specified rule.

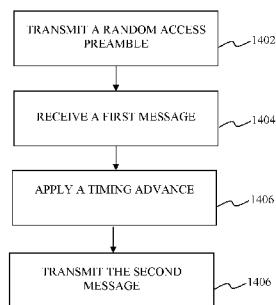

FIG. 14



## **RANDOM ACCESS RECEPTION AND MESSAGE 3 TRANSMISSION FOR NEW RADIO (NR) BASED SATELLITE COMMUNICATION**

### **CROSS-REFERENCE TO RELATED APPLICATIONS**

**[0001]** The present application claims the benefit of U.S. Provisional Patent Appl. No. 62/796,976, filed January 25, 2019, which is incorporated herein by reference in its entirety.

### **FIELD**

**[0002]** Various embodiments generally may relate to the field of wireless communications.

### **SUMMARY**

**[0003]** Some embodiments of this disclosure can include a method for performing a Random Access Channel (RACH) procedure. The method can include receiving a first message including a time-frequency resource for uplink transmission and a timing advance value, applying a timing advance according to the timing advance value prior to transmitting a second message, and transmitting, in the time-frequency resource, the second message in a time slot of a subframe that occurs after the timing advance.

**[0004]** In some embodiments, the first message can include a random access response (RAR) message, and the second message can include a control plane message. In some embodiments, the control plane message can be a connection request message or a connection resume message. In some embodiments, the second message can be message 3.

**[0005]** In some embodiments, the time slot can be dependent on an altitude of a satellite.

**[0006]** In some embodiments, the method can further include transmitting a third message prior to receiving the first message. In these embodiments, the third message can be a random access preamble.

**[0007]** Some embodiments of this disclosure can include an apparatus for performing a Random Access Channel (RACH) procedure. The apparatus can include radio front end

- 2 -

circuitry and processor circuitry. The radio front end circuitry can receive a first message including a time-frequency resource for uplink transmission and a timing advance value, and transmit, in the time-frequency resource, a second message in a time slot of a subframe that occurs after the timing advance in response to the first message. The processor circuitry can apply a timing advance according to the timing advance value prior to the radio front end circuitry transmitting the second message.

- [0008]** In some embodiments, the first message can include a random access response (RAR) message, and the second message can include a control plane message. In some embodiments, the control plane message can be a connection request message or a connection resume message. In some embodiments, second message can be a message 3.
- [0009]** In some embodiments, the time slot can be dependent on an altitude of a satellite.
- [0010]** In some embodiments, the radio front end circuitry can further transmit a third message prior to receiving the first message. In these embodiments, the third message can be a random access preamble.
- [0011]** Some embodiments of this disclosure can include a system for performing a Random Access Channel (RACH) procedure. The system can include a user equipment (UE) and a Next Generation NodeB (gNB). The gNB can transmit a first message including a time-frequency resource for uplink transmission and a timing advance value. The UE can apply a timing advance according to the timing advance value prior to transmitting a second message, and transmit, in the time-frequency resource, the second message in a time slot of a subframe that occurs after the timing advance in response to the first message.
- [0012]** In some embodiments, the first message can include a random access response (RAR) message, and the second message can include a control plane message. In some embodiments, the control plane message can be a connection request message or a connection resume message. In some embodiments, second message can be a message 3.
- [0013]** In some embodiments, the UE can further transmit a third message prior to receiving the first message. In these embodiments, the third message can be a random access preamble.
- [0014]** In some embodiments, the time slot can be dependent on an altitude of a satellite.
- [0015]** Any of the above-described embodiments may be combined with any other embodiments (or combination of embodiments), unless explicitly stated otherwise. The

foregoing description of one or more implementations provides illustration and description, but is not intended to be exhaustive or to limit the scope of embodiments to the precise form disclosed. Modifications and variations are possible in light of the above teachings or may be acquired from practice of various embodiments.

## BRIEF DESCRIPTION OF THE DRAWINGS/FIGURES

- [0016] The present disclosure is described with reference to the accompanying drawings. In the drawings, like reference numbers indicate identical or functionally similar elements. Additionally, the left most digit(s) of a reference number identifies the drawing in which the reference number first appears. In the accompanying drawings:
- [0017] FIG. 1 graphically illustrates a propagation delay and its effect on time alignment;
- [0018] FIG. 2 graphically illustrates application of a timing advance;
- [0019] FIG. 3 graphically illustrates an exemplary rule for determining the time of application of the UL grant in accordance with various embodiments;
- [0020] FIG. 4 illustrates an example architecture of a system of a network in accordance with various embodiments;
- [0021] FIG. 5 illustrates an example architecture of a system including a first CN in accordance with various embodiments;
- [0022] FIG. 6 illustrates an architecture of a system including a second CN in accordance with various embodiments;
- [0023] FIG. 7 illustrates an example of infrastructure equipment in accordance with various embodiments;
- [0024] FIG. 8 illustrates an example of a platform in accordance with various embodiments;
- [0025] FIG. 9 illustrates example components of baseband circuitry and radio front end modules (RFEM) in accordance with various embodiments;
- [0026] FIG. 10 illustrates various protocol functions that can be implemented in a wireless communication device in accordance with various embodiments;
- [0027] FIG. 11 illustrates components of a core network in accordance with various embodiments;
- [0028] FIG. 12 is a block diagram illustrating components, according to some embodiments, of a system to support Network Functions Virtualization (NFV);

- [0029] FIG. 13 is a block diagram illustrating components, according to some embodiments, able to read instructions from a machine-readable or computer-readable medium (e.g., a non-transitory machine-readable storage medium) and perform any one or more of the methodologies discussed herein; and
- [0030] FIG. 14 illustrates a flowchart for performing a Random Access Channel (RACH) procedure according to some embodiments.
- [0031] The present disclosure will now be described with reference to the accompanying drawings.

## DETAILED DESCRIPTION OF THE DISCLOSURE

- [0032] The following detailed description refers to the accompanying drawings. The same reference numbers may be used in different drawings to identify the same or similar elements. In the following description, for purposes of explanation and not limitation, specific details are set forth such as particular structures, architectures, interfaces, techniques, etc. in order to provide a thorough understanding of the various aspects of various embodiments. However, it will be apparent to those skilled in the art having the benefit of the present disclosure that the various aspects of the various embodiments may be practiced in other examples that depart from these specific details. In certain instances, descriptions of well-known devices, circuits, and methods are omitted so as not to obscure the description of the various embodiments with unnecessary detail. For the purposes of the present document, the phrase “A or B” means (A), (B), or (A and B).

### Overview

- [0033] New Radio (NR) based satellite communication is being studied in the third generation partnership project (3GPP) with an intention to design an air interface that supports Non-terrestrial networks (NTNs). A number of use cases have been identified including various enhanced mobile broadband (eMBB) and machine type communications (MTC) scenarios. The goal in 3GPP is to appropriately enhance 3GPP NR air interface protocols and network architectures such that NTNs can be supported.
- [0034] One of the primary differences in NTNs compared to terrestrial cellular networks is the significantly longer propagation delay between the user equipment (UE), which is on the ground, and the satellite, which is not on the ground.

**[0035]** FIG. 1 graphically illustrates a propagation delay and its effect on time alignment. Assuming a satellite functions as a base station (gNB), then FIG. 1 illustrates the propagation delay and its effect on time alignment at the UE. Propagation delays can result in the uplink signal from different UEs being received at the gNB at very different times. As illustrated in FIG. 1, the gNB assigns timing advances to UEs to ensure that the receive times of signals from UEs are the same to be able to receive multiple uplink (UL) signals. In some embodiments, the timing advance value is communicated to the UEs in the random access procedure (e.g., in the random access response, etc.). In some embodiments, the time alignment value used is approximately equal to twice the propagation delay between the satellite and the UE to ensure alignment and frame boundaries for downlink (DL) and UL at the gNB. In those embodiments including terrestrial networks, the propagation delay and the timing advance can be within the duration of one orthogonal frequency-division multiplexing (OFDM) symbol. In those embodiments including terrestrial networks, due to the large propagation delay, the timing advance value required can be much larger than in terrestrial networks. In these embodiments, the frame alignment before and after applying the timing advance can be very different.

**[0036]** The embodiments to be described in further detail below assist with enabling a UE to transmit message 3 in an NTN network. These embodiments can enable support of NR Random Access Procedure (RACH) in satellite networks with minimal changes and minimal impact to UEs. These embodiments can be targeted to work in 3GPP on NTNs.

#### RAR and Message 3 transmission

**[0037]** The Random Access Channel (RACH) procedure represents a four-message (e.g., message 1, message 2, message 3, and message 4) handshake between the UE device and the gNB. In this procedure, message 1 represents a random access preamble that is transmitted by the UE. In an exemplary embodiment, the UE can transmit the random access preamble to the gNB over a satellite over Physical Random Access (PRACH) channel to obtain uplink (UL) synchronization. The UE can transmit the random access preamble in predefined time-frequency resources. The gNB, upon receiving the RACH preamble, can compute an appropriate timing advance, for example, by observing the propagation delay. The gNB transmits the message 2, also referred to as a random access response (RAR) message, to the UE that includes the timing advance to be applied

- 6 -

by the UE and an uplink resource grant for transmission of message 3. The uplink grant is used by the UE six subframes after the subframe in which the RAR is received to transmit message 3. Message 3 represents a control plane message such as connection request or connection resume. In some embodiments, message 3 is associated with the Long Term Evolution (LTE) communication standard, or another standard, as defined by the Third Generation Partnership Project (3GPP). Upon receiving the RAR, the UE applies the timing advance (i.e., advances the timing of its uplink frames by the specified timing advance value) and then assembles and transmits message 3. The timing advance value can be substantially large for NTN. For example, with a satellite at 600 km altitude above the Earth's surface, the timing advance required is approximately 4 ms.

The duration between the reception of the RAR message and the transmission of message 3 can be used by the UE to assemble the protocol data unit (PDU) for transmission. The gNB, upon receiving the message 3, responds with message 4. Message 4 represents a control plane message such as connection setup.

**[0038]** FIG. 2 graphically illustrates application of a timing advance. As illustrated in FIG. 2, the satellite 208 can receive the RACH preamble 202 from the UE 206. Thereafter, an appropriate timing advance can be computed, for example, by observing the propagation delay. The RAR message 204 that includes the timing advance to be applied by the UE 206 and an uplink resource grant for transmission of message 3 can be transmitted to the UE 206. In the example illustrated in FIG. 2, the UE 206 applies the timing advance upon reception of the RAR message 204. This can result in a shift of transmit (uplink) frame timing so that they occur before the corresponding downlink frames. In the example illustrated in FIG. 2, the UE 206 is expected to transmit message 3 210 in subframe  $n+11$  (after receiving the RAR 204 in subframe  $n+5$ ). However, due to the application of timing advance, the time between the RAR message 204 reception and the message 3 210 transmission is very short. As the propagation delay increases, the time at which the UE 206 is expected to transmit message 3 210 can occur before the reception of the RAR by the UE 206 (e.g., for a satellite 208 at altitude of 35786 km, the timing advance required is approximately 238 ms). In this situation, the UE 206 may not be able to transmit message 3 210 in the resource allocated in the RAR message 204 because the UE 206 has not received the RAR message 204 early enough to process the RAR

message 204 and transmit the message 3 210 before the time allocated in the RAR message 204, namely, subframe  $n+11$ .

Exemplary transmissions of message 3 in an NTN network.

**[0039]** The embodiments to be described in further detail below include methods and apparatuses that enable the UE to transmit message 3 in an NTN network.

**[0040]** In some embodiments, a RAR message includes time of uplink (UL) grant application. In some embodiments, the gNB can include, in the RAR message, a time duration indicating the time at which the UE should transmit message 3. In these embodiments, the time duration is largely determined by satellite altitude. For example, for satellites at an altitude of 600 km, the RAR message can indicate a 12 ms time period (i.e., the transmission of message 3 would be in subframe  $n+12$ ). In these embodiments, the network can ensure that the UE has adequate time to apply the timing advance, assemble and transmit message 3, upon reception of the RAR.

**[0041]** In some embodiments, the UE can compute time of UL grant application based on a timing advance. In these embodiments, the time of application of the UL grant can be determined by the UE and by the gNB according to a specified rule.

**[0042]** FIG. 3 graphically illustrates an exemplary rule for determining the time of application of the UL grant in accordance with various embodiments. As illustrated in FIG. 3, a satellite, not illustrated in FIG. 3, can receive the RACH preamble from the UE 306. Thereafter, an appropriate timing advance can be computed, for example, by observing the propagation delay. The RAR message 302 that includes the timing advance to be applied by the UE 306 and an uplink resource grant for transmission of message 3 can be transmitted to the UE 306. The exemplary embodiment of the exemplary rule illustrated in FIG. 3 can cause the UE 306 to apply the UL grant in the first subframe that occurs after  $T_{TA} + 6$ , where  $T_{TA}$  is the timing advance provided in the RAR message 302. In this exemplary embodiment, the gNB can compensate for the timing advance in determining the time of application of the uplink grant.

Exemplary Systems

**[0043]** FIG. 4 illustrates an example architecture of a system of a network in accordance with various embodiments. The following description is provided for an example system 400 that operates in conjunction with the Long Term Evolution (LTE) system standards

- 8 -

and Fifth Generation (5G) or NR system standards as provided by Third Generation Partnership Project (3GPP) technical specifications. However, the example embodiments are not limited in this regard and the described embodiments may apply to other networks that benefit from the principles described herein, such as future 3GPP systems (e.g., Sixth Generation (6G)) systems, IEEE 802.16 protocols (e.g., WMAN, WiMAX, etc.), or the like.

**[0044]** As illustrated in FIG. 4, the system 400 includes User Equipment (UE) 401a and UE 401b (collectively referred to as “UEs 401” or “UE 401”). In this example, UEs 401 are illustrated as smartphones (e.g., handheld touchscreen mobile computing devices connectable to one or more cellular networks), but may also comprise any mobile or non-mobile computing device, such as consumer electronics devices, cellular phones, smartphones, feature phones, tablet computers, wearable computer devices, personal digital assistants (PDAs), pagers, wireless handsets, desktop computers, laptop computers, in-vehicle infotainment (IVI), in-car entertainment (ICE) devices, an Instrument Cluster (IC), head-up display (HUD) devices, onboard diagnostic (OBD) devices, dashtop mobile equipment (DME), mobile data terminals (MDTs), Electronic Engine Management System (EEMS), electronic/engine control units (ECUs), electronic/engine control modules (ECMs), embedded systems, microcontrollers, control modules, engine management systems (EMS), networked or “smart” appliances, MTC devices, M2M, IoT devices, and/or the like.

**[0045]** In some embodiments, any of the UEs 401 may be Internet of Things (IoT) UEs, which may comprise a network access layer designed for low-power IoT applications utilizing short-lived UE connections. An IoT UE can utilize technologies such as Machine-to-Machine (M2M) or Machine-Type Communications (MTC) for exchanging data with an MTC server or device via a Public Land Mobile Network (PLMN), Proximity-Based Service (ProSe), or Device-to-Device (D2D) communication, sensor networks, or IoT networks. The M2M or MTC exchange of data may be a machine-initiated exchange of data. An IoT network describes interconnecting IoT UEs, which can include uniquely identifiable embedded computing devices (within the Internet infrastructure), with short-lived connections. The IoT UEs may execute background applications (e.g., keep-alive messages, status updates, etc.) to facilitate the connections of the IoT network.

**[0046]** The UEs 401 can be configured to connect, for example, communicatively couple, with a Radio Access Network (RAN) 410. In some embodiments, the RAN 410 may be a Next Generation (NG) RAN or a 5G RAN, an evolved Universal Terrestrial Radio Access Network (E-UTRAN), or a legacy RAN, such as a UTRAN or GSM EDGE Radio Access Network (GERAN). As used herein, the term “NG RAN,” or the like, may refer to a RAN 410 that operates in an NR or 5G system 400, and the term “E-UTRAN,” or the like, may refer to a RAN 410 that operates in an LTE or 4G system 400. The UEs 401 utilize connections (or channels) 403 and 404, respectively, each of which comprises a physical communications interface or layer (discussed in further detail below).

**[0047]** In this example, the connections 403 and 404 are illustrated as an air interface to enable communicative coupling, and can be consistent with cellular communications protocols, such as a Global System for Mobile Communications (GSM) protocol, a Code-Division Multiple Access (CDMA) network protocol, a Push-to-Talk (PTT) protocol, a Push-to-Talk over Cellular (POC) protocol, a Universal Mobile Telecommunications System (UMTS) protocol, a 3GPP LTE protocol, a 5G protocol, a NR protocol, and/or any of the other communications protocols discussed herein. In some embodiments, the UEs 401 may directly exchange communication data via a Proximity-Based Service (ProSe) interface 405. The ProSe interface 405 may alternatively be referred to as a sidelink (SL) interface 405 and may comprise one or more logical channels, including but not limited to a Physical Sidelink Control Channel (PSCCH), a Physical Sidelink Shared Channel (PSSCH), a Physical Sidelink Downlink Channel (PSDCH), and a Physical Sidelink Broadcast Channel (PSBCH).

**[0048]** The UE 401b is shown to be configured to access an Access Point (AP) 406 (also referred to as “WLAN node 406,” “WLAN 406,” “WLAN Termination 406,” “WT 406” or the like) via connection 407. The connection 407 can comprise a local wireless connection, such as a connection consistent with any IEEE 802.11 protocol, wherein the AP 406 would comprise a wireless fidelity (Wi-Fi®) router. In this example, the AP 406 is shown to be connected to the Internet without connecting to the core network of the wireless system (described in further detail below). In various embodiments, the UE 401b, RAN 410, and AP 406 can be configured to utilize LWA operation and/or LWIP operation. The LWA operation may involve the UE 401b in RRC\_CONNECTED being configured by a RAN node 411a-b to utilize radio resources of LTE and WLAN. LWIP

operation may involve the UE 401b using WLAN radio resources (e.g., connection 407) via IPsec protocol tunneling to authenticate and encrypt packets (e.g., IP packets) sent over the connection 407. IPsec tunneling can include encapsulating the entirety of original IP packets and adding a new packet header, thereby protecting the original header of the IP packets.

**[0049]** The RAN 410 can include one or more AN nodes or RAN nodes 411a and 411b (collectively referred to as “RAN nodes 411” or “RAN node 411”) that enable the connections 403 and 404. As used herein, the terms “access node,” “access point,” or the like may describe equipment that provides the radio baseband functions for data and/or voice connectivity between a network and one or more users. These access nodes can be referred to as BS, gNBs, RAN nodes, eNBs, NodeBs, RSUs, TRxPs or TRPs, and so forth, and can comprise ground stations (e.g., terrestrial access points) or satellite stations providing coverage within a geographic area (e.g., a cell). As used herein, the term “NG RAN node” or the like may refer to a RAN node 411 that operates in an NR or 5G system 400 (for example, a gNB), and the term “E-UTRAN node” or the like may refer to a RAN node 411 that operates in an LTE or 4G system 400 (e.g., an eNB). In accordance with various embodiments, the RAN nodes 411 can be implemented as one or more of a dedicated physical device such as a macrocell base station, and/or a low power (LP) base station for providing femtocells, picocells or other like cells having smaller coverage areas, smaller user capacity, or higher bandwidth compared to macrocells.

**[0050]** In some embodiments, all or parts of the RAN nodes 411 can be implemented as one or more software entities running on server computers as part of a virtual network, which may be referred to as a CRAN and/or a virtual baseband unit pool (vBBUP). In these embodiments, the CRAN or vBBUP may implement a RAN function split, such as a PDCP split wherein RRC and PDCP layers are operated by the CRAN/vBBUP and other L2 protocol entities are operated by individual RAN nodes 411; a MAC/PHY split wherein RRC, PDCP, RLC, and MAC layers are operated by the CRAN/vBBUP and the PHY layer is operated by individual RAN nodes 411; or a “lower PHY” split wherein RRC, PDCP, RLC, MAC layers and upper portions of the PHY layer are operated by the CRAN/vBBUP and lower portions of the PHY layer are operated by individual RAN nodes 411. This virtualized framework allows the freed-up processor cores of the RAN nodes 411 to perform other virtualized applications. In some embodiments, an individual

- 11 -

RAN node 411 may represent individual gNB-DUs that are connected to a gNB-CU via individual F1 interfaces (not illustrated in FIG. 4). In these implementations, the gNB-DUs can include one or more remote radio heads or RFEMs (see, for example, FIG. 7), and the gNB-CU may be operated by a server that is located in the RAN 410 (not shown) or by a server pool in a similar manner as the CRAN/vBBUP. Additionally or alternatively, one or more of the RAN nodes 411 may be next generation eNBs (ng-eNBs), which are RAN nodes that provide E-UTRA user plane and control plane protocol terminations toward the UEs 401, and are connected to a 5GC (e.g., CN 620 of FIG. 6) via an NG interface (discussed infra).

**[0051]** In V2X scenarios, one or more of the RAN nodes 411 may be or act as RSUs. The term “Road Side Unit” or “RSU” may refer to any transportation infrastructure entity used for V2X communications. An RSU can be implemented in or by a suitable RAN node or a stationary (or relatively stationary) UE, where an RSU implemented in or by a UE may be referred to as a “UE-type RSU,” an RSU implemented in or by an eNB may be referred to as an “eNB-type RSU,” an RSU implemented in or by a gNB may be referred to as a “gNB-type RSU,” and the like. In one example, an RSU is a computing device coupled with radio frequency circuitry located on a roadside that provides connectivity support to passing vehicle UEs 401 (vUEs 401). The RSU may also include internal data storage circuitry to store intersection map geometry, traffic statistics, media, as well as applications/software to sense and control ongoing vehicular and pedestrian traffic. The RSU may operate on the 5.9 GHz Direct Short Range Communications (DSRC) band to provide very low latency communications required for high speed events, such as crash avoidance, traffic warnings, and the like. Additionally or alternatively, the RSU may operate on the cellular V2X band to provide the aforementioned low latency communications, as well as other cellular communications services. Additionally or alternatively, the RSU may operate as a Wi-Fi hotspot (2.4 GHz band) and/or provide connectivity to one or more cellular networks to provide uplink and downlink communications. The computing device(s) and some or all of the radiofrequency circuitry of the RSU may be packaged in a weatherproof enclosure suitable for outdoor installation, and can include a network interface controller to provide a wired connection (e.g., Ethernet) to a traffic signal controller and/or a backhaul network.

- [0052]** Any of the RAN nodes 411 can terminate the air interface protocol and can be the first point of contact for the UEs 401. In some embodiments, any of the RAN nodes 411 can fulfill various logical functions for the RAN 410 including, but not limited to, radio network controller (RNC) functions such as radio bearer management, uplink and downlink dynamic radio resource management and data packet scheduling, and mobility management.
- [0053]** In some embodiments, the UEs 401 can be configured to communicate using OFDM communication signals with each other or with any of the RAN nodes 411 over a multicarrier communication channel in accordance with various communication techniques, such as, but not limited to, an OFDMA communication technique (e.g., for downlink communications) or a SC-FDMA communication technique (e.g., for uplink and ProSe or sidelink communications), although the scope of the embodiments is not limited in this respect. The OFDM signals can comprise a plurality of orthogonal subcarriers.
- [0054]** In some embodiments, a downlink resource grid can be used for downlink transmissions from any of the RAN nodes 411 to the UEs 401, while uplink transmissions can utilize similar techniques. The grid can be a time-frequency grid, called a resource grid or time-frequency resource grid, which is the physical resource in the downlink in each slot. Such a time-frequency plane representation is a common practice for OFDM systems, which makes it intuitive for radio resource allocation. Each column and each row of the resource grid corresponds to one OFDM symbol and one OFDM subcarrier, respectively. The duration of the resource grid in the time domain corresponds to one slot in a radio frame. The smallest time-frequency unit in a resource grid is denoted as a resource element. Each resource grid comprises a number of resource blocks, which describe the mapping of certain physical channels to resource elements. Each resource block comprises a collection of resource elements; in the frequency domain, this may represent the smallest quantity of resources that currently can be allocated. There are several different physical downlink channels that are conveyed using such resource blocks.
- [0055]** In accordance with various embodiments, the UEs 401 and the RAN nodes 411 communicate data (for example, transmit and receive) data over a licensed medium (also referred to as the “licensed spectrum” and/or the “licensed band”) and an unlicensed

shared medium (also referred to as the “unlicensed spectrum” and/or the “unlicensed band”). The licensed spectrum can include channels that operate in the frequency range of approximately 400 MHz to approximately 3.8 GHz, whereas the unlicensed spectrum can include the 5 GHz band.

**[0056]** To operate in the unlicensed spectrum, the UEs 401 and the RAN nodes 411 may operate using LAA, eLAA, and/or feLAA mechanisms. In these implementations, the UEs 401 and the RAN nodes 411 may perform one or more known medium-sensing operations and/or carrier-sensing operations in order to determine whether one or more channels in the unlicensed spectrum is unavailable or otherwise occupied prior to transmitting in the unlicensed spectrum. The medium/carrier sensing operations may be performed according to a listen-before-talk (LBT) protocol.

**[0057]** LBT is a mechanism whereby equipment (for example, UEs 401, RAN nodes 411, etc.) senses a medium (for example, a channel or carrier frequency) and transmits when the medium is sensed to be idle (or when a specific channel in the medium is sensed to be unoccupied). The medium sensing operation can include CCA, which utilizes at least ED to determine the presence or absence of other signals on a channel in order to determine if a channel is occupied or clear. This LBT mechanism allows cellular/LAA networks to coexist with incumbent systems in the unlicensed spectrum and with other LAA networks. ED can include sensing RF energy across an intended transmission band for a period of time and comparing the sensed RF energy to a predefined or configured threshold.

**[0058]** Typically, the incumbent systems in the 5 GHz band are WLANs based on IEEE 802.11 technologies. WLAN employs a contention-based channel access mechanism, called CSMA/CA. Here, when a WLAN node (e.g., a mobile station (MS) such as UE 401, AP 406, or the like) intends to transmit, the WLAN node may first perform CCA before transmission. Additionally, a backoff mechanism is used to avoid collisions in situations where more than one WLAN node senses the channel as idle and transmits at the same time. The backoff mechanism may be a counter that is drawn randomly within the CWS, which is increased exponentially upon the occurrence of collision and reset to a minimum value when the transmission succeeds. The LBT mechanism designed for LAA is somewhat similar to the CSMA/CA of WLAN. In some embodiments, the LBT procedure for DL or UL transmission bursts including PDSCH or PUSCH transmissions,

respectively, may have an LAA contention window that is variable in length between X and Y ECCA slots, where X and Y are minimum and maximum values for the CWSs for LAA. In one example, the minimum CWS for an LAA transmission may be 9 microseconds ( $\mu\text{s}$ ); however, the size of the CWS and a MCOT (for example, a transmission burst) may be based on governmental regulatory requirements.

**[0059]** The LAA mechanisms are built upon CA technologies of LTE-Advanced systems. In CA, each aggregated carrier is referred to as a CC. A CC may have a bandwidth of 1.4, 3, 5, 10, 15 or 20 MHz and a maximum of five CCs can be aggregated, and therefore, a maximum aggregated bandwidth is 100 MHz. In FDD systems, the number of aggregated carriers can be different for DL and UL, where the number of UL CCs is equal to or lower than the number of DL component carriers. In some cases, individual CCs can have a different bandwidth than other CCs. In TDD systems, the number of CCs as well as the bandwidths of each CC is usually the same for DL and UL.

**[0060]** CA also comprises individual serving cells to provide individual CCs. The coverage of the serving cells may differ, for example, because CCs on different frequency bands will experience different pathloss. A primary service cell or PCell provides a PCC for both UL and DL, and handles RRC and NAS related activities. The other serving cells are referred to as SCells, and each SCell provides an individual SCC for both UL and DL. The SCCs may be added and removed as required, while changing the PCC may require the UE 401 to undergo a handover. In LAA, eLAA, and feLAA, some or all of the SCells may operate in the unlicensed spectrum (referred to as "LAA SCells"), and the LAA SCells are assisted by a PCell operating in the licensed spectrum. When a UE is configured with more than one LAA SCell, the UE may receive UL grants on the configured LAA SCells indicating different PUSCH starting positions within a same subframe.

**[0061]** The PDSCH carries user data and higher-layer signaling to the UEs 401. The PDCCH carries information about the transport format and resource allocations related to the PDSCH channel, among other things. It may also inform the UEs 401 about the transport format, resource allocation, and HARQ information related to the uplink shared channel. Typically, downlink scheduling (assigning control and shared channel resource blocks to the UE 401b within a cell) may be performed at any of the RAN nodes 411 based on channel quality information fed back from any of the UEs 401. The downlink

resource assignment information may be sent on the PDCCH used for (e.g., assigned to) each of the UEs 401.

- [0062]** The PDCCH uses CCEs to convey the control information. Before being mapped to resource elements, the PDCCH complex-valued symbols may first be organized into quadruplets, which may then be permuted using a sub-block interleaver for rate matching. Each PDCCH may be transmitted using one or more of these CCEs, where each CCE may correspond to nine sets of four physical resource elements known as REGs. Four Quadrature Phase Shift Keying (QPSK) symbols may be mapped to each REG. The PDCCH can be transmitted using one or more CCEs, depending on the size of the DCI and the channel condition. There can be four or more different PDCCH formats defined in LTE with different numbers of CCEs (e.g., aggregation level,  $L=1, 2, 4,$  or  $8$ ).
- [0063]** Some embodiments may use concepts for resource allocation for control channel information that are an extension of the above-described concepts. For example, some embodiments may utilize an EPDCCH that uses PDSCH resources for control information transmission. The EPDCCH may be transmitted using one or more ECCEs. Similar to above, each ECCE may correspond to nine sets of four physical resource elements known as an EREGs. An ECCE may have other numbers of EREGs in some situations.
- [0064]** The RAN nodes 411 can be configured to communicate with one another via interface 412. In some embodiments where the system 400 is an LTE system (e.g., when CN 420 is an EPC 520 as in FIG. 5), the interface 412 may be an X2 interface 412. The X2 interface may be defined between two or more RAN nodes 411 (e.g., two or more eNBs and the like) that connect to EPC 420, and/or between two eNBs connecting to EPC 420. In some embodiments, the X2 interface can include an X2 user plane interface (X2-U) and an X2 control plane interface (X2-C). The X2-U provides flow control mechanisms for user data packets transferred over the X2 interface, and may be used to communicate information about the delivery of user data between eNBs. For example, the X2-U provides specific sequence number information for user data transferred from a MeNB to an SeNB; information about successful in sequence delivery of PDCP PDUs to a UE 401 from an SeNB for user data; information of PDCP PDUs that were not delivered to a UE 401; information about a current minimum desired buffer size at the SeNB for transmitting to the UE user data; and the like. The X2-C provides intra-LTE

access mobility functionality, including context transfers from source to target eNBs, user plane transport control, etc.; load management functionality; as well as inter-cell interference coordination functionality.

**[0065]** In some embodiments where the system 400 is a 5G or NR system (e.g., when CN 420 is an 5GC 620 as in FIG. 6), the interface 412 may be an Xn interface 412. The Xn interface is defined between two or more RAN nodes 411 (e.g., two or more Next Generation NodeBs (gNBs) and the like) that connect to 5GC 420, between a RAN node 411 (e.g., a gNB) connecting to 5GC 420 and an evolved NodeB (eNB), and/or between two eNBs connecting to 5GC 420. In some embodiments, the Xn interface can include an Xn user plane (Xn-U) interface and an Xn control plane (Xn-C) interface. The Xn-U provides non-guaranteed delivery of user plane Protocol Data Units (PDUs) and support/provide data forwarding and flow control functionality. The Xn-C provides management and error handling functionality, functionality to manage the Xn-C interface; mobility support for UE 401 in a connected mode (e.g., CM-CONNECTED) including functionality to manage the UE mobility for connected mode between one or more RAN nodes 411. The mobility support can include context transfer from an old (source) serving RAN node 411 to new (target) serving RAN node 411; and control of user plane tunnels between old (source) serving RAN node 411 to new (target) serving RAN node 411. A protocol stack of the Xn-U can include a transport network layer built on Internet Protocol (IP) transport layer, and a GPRS Tunnelling Protocol for User Plane (GTP-U) layer on top of a User Datagram Protocol (UDP) and/or IP layer(s) to carry user plane PDUs. The Xn-C protocol stack can include an application layer signaling protocol (referred to as Xn Application Protocol (Xn-AP)) and a transport network layer that is built on Stream Control Transmission Protocol (SCTP). The SCTP may be on top of an IP layer, and provides the guaranteed delivery of application layer messages. In the transport IP layer, point-to-point transmission is used to deliver the signaling PDUs. In other implementations, the Xn-U protocol stack and/or the Xn-C protocol stack may be same or similar to the user plane and/or control plane protocol stack(s) shown and described herein.

**[0066]** The RAN 410 is shown to be communicatively coupled to a core network—in this embodiment, core network (CN) 420. The CN 420 may comprise a plurality of network elements 422, which are configured to offer various data and telecommunications services

to customers/subscribers (e.g., users of UEs 401) who are connected to the CN 420 via the RAN 410. The components of the CN 420 can be implemented in one physical node or separate physical nodes including components to read and execute instructions from a machine-readable or computer-readable medium (e.g., a non-transitory machine-readable storage medium). In some embodiments, Network Functions Virtualization (NFV) may be utilized to virtualize any or all of the above-described network node functions via executable instructions stored in one or more computer-readable storage mediums (described in further detail below). A logical instantiation of the CN 420 may be referred to as a network slice, and a logical instantiation of a portion of the CN 420 may be referred to as a network sub-slice. NFV architectures and infrastructures may be used to virtualize one or more network functions, alternatively performed by proprietary hardware, onto physical resources comprising a combination of industry-standard server hardware, storage hardware, or switches. In other words, NFV systems can be used to execute virtual or reconfigurable implementations of one or more EPC components/functions.

**[0067]** Generally, the application server 430 may be an element offering applications that use IP bearer resources with the core network (e.g., Universal Mobile Telecommunications System (UMTS) Packet Services (PS) domain, LTE PS data services, etc.). The application server 430 can also be configured to support one or more communication services (e.g., VoIP sessions, PTT sessions, group communication sessions, social networking services, etc.) for the UEs 401 via the CN 420.

**[0068]** In some embodiments, the CN 420 may be a 5GC (referred to as “5GC 420” or the like), and the RAN 410 may be connected with the CN 420 via an NG interface 413. In some embodiments, the NG interface 413 may be split into two parts, an NG user plane (NG-U) interface 414, which carries traffic data between the RAN nodes 411 and a UPF, and the S1 control plane (NG-C) interface 215, which is a signaling interface between the RAN nodes 411 and AMFs. Embodiments where the CN 420 is a 5GC 420 are discussed in more detail with regard to FIG. 6.

**[0069]** In some embodiments, the CN 420 may be a 5G CN (referred to as “5GC 420” or the like), while in other embodiments, the CN 420 may be an EPC. Where CN 420 is an EPC (referred to as “EPC 420” or the like), the RAN 410 may be connected with the CN 420 via an S1 interface 413. In some embodiments, the S1 interface 413 may be split into

two parts, an S1 user plane (S1-U) interface 414, which carries traffic data between the RAN nodes 411 and the S-GW, and the S1-MME interface 215, which is a signaling interface between the RAN nodes 411 and MMEs. An example architecture wherein the CN 420 is an EPC 420 is illustrated in FIG. 5.

#### Exemplary Architectures

**[0070]** FIG. 5 illustrates an example architecture of a system 500 including a first CN 520 in accordance with various embodiments. In this example, system 500 may implement the LTE standard wherein the CN 520 is an EPC 520 that corresponds with CN 420 of FIG. 4. Additionally, the UE 501 may be the same or similar as the UEs 401 of FIG. 4, and the E-UTRAN 510 may be a RAN that is the same or similar to the RAN 410 of FIG. 4, and which can include RAN nodes 411 discussed previously. The CN 520 may comprise Mobility Management Entities (MMEs) 521, a Serving Gateway (S-GW) 522, a PDN Gateway (P-GW) 523, a Home Subscriber Server (HSS) 524, and a Serving GPRS Support Node (SGSN) 525.

**[0071]** The MMEs 521 may be similar in function to the control plane of legacy SGSN, and may implement Mobility Management (MM) functions to keep track of the current location of a UE 501. The MMEs 521 may perform various MM procedures to manage mobility aspects in access such as gateway selection and tracking area list management. MM (also referred to as “EPS MM” or “EMM” in E-UTRAN systems) may refer to all applicable procedures, methods, data storage, etc. that are used to maintain knowledge about a present location of the UE 501, provide user identity confidentiality, and/or perform other like services to users/subscribers. Each UE 501 and the MME 521 can include an MM or EMM sublayer, and an MM context may be established in the UE 501 and the MME 521 when an attach procedure is successfully completed. The MM context may be a data structure or database object that stores MM-related information of the UE 501. The MMEs 521 may be coupled with the HSS 524 via an S6a reference point, coupled with the SGSN 525 via an S3 reference point, and coupled with the S-GW 522 via an S11 reference point.

**[0072]** The SGSN 525 may be a node that serves the UE 501 by tracking the location of an individual UE 501 and performing security functions. In addition, the SGSN 525 may perform Inter-EPC node signaling for mobility between 2G/3G and E-UTRAN 3GPP access networks; PDN and S-GW selection as specified by the MMEs 521; handling of

UE 501 time zone functions as specified by the MMEs 521; and MME selection for handovers to E-UTRAN 3GPP access network. The S3 reference point between the MMEs 521 and the SGSN 525 may enable user and bearer information exchange for inter-3GPP access network mobility in idle and/or active states.

- [0073]** The HSS 524 may comprise a database for network users, including subscription-related information to support the network entities' handling of communication sessions. The EPC 520 may comprise one or several HSSs 524, depending on the number of mobile subscribers, on the capacity of the equipment, on the organization of the network, etc. For example, the HSS 524 can provide support for routing/roaming, authentication, authorization, naming/addressing resolution, location dependencies, etc. An S6a reference point between the HSS 524 and the MMEs 521 may enable transfer of subscription and authentication data for authenticating/authorizing user access to the EPC 520 between HSS 524 and the MMEs 521.
- [0074]** The S-GW 522 may terminate the S1 for the user plane (S1-U) interface toward the RAN 510, and routes data packets between the RAN 510 and the EPC 520. In addition, the S-GW 522 may be a local mobility anchor point for inter-RAN node handovers and also provides an anchor for inter-3GPP mobility. Other responsibilities can include lawful intercept, charging, and some policy enforcement. The S11 reference point between the S-GW 522 and the MMEs 521 provides a control plane between the MMEs 521 and the S-GW 522. The S-GW 522 may be coupled with the P-GW 523 via an S5 reference point.
- [0075]** The P-GW 523 may terminate an SGi interface toward a PDN 530. The P-GW 523 may route data packets between the EPC 520 and external networks such as a network including the application server 430 (alternatively referred to as an "AF") via an IP interface 425 (see e.g., FIG. 4). In some embodiments, the P-GW 523 may be communicatively coupled to an application server (application server 430 of FIG. 4 or PDN 530 in FIG. 5) via an IP communications interface 425 (see, e.g., FIG. 4). The S5 reference point between the P-GW 523 and the S-GW 522 provides user plane tunneling and tunnel management between the P-GW 523 and the S-GW 522. The S5 reference point may also be used for S-GW 522 relocation due to UE 501 mobility and if the S-GW 522 needs to connect to a non-collocated P-GW 523 for the required PDN connectivity. The P-GW 523 may further include a node for policy enforcement and charging data

collection (e.g., PCEF (not shown)). Additionally, the SGi reference point between the P-GW 523 and the packet data network (PDN) 530 may be an operator external public, a private PDN, or an intra operator packet data network, for example, for provision of IMS services. The P-GW 523 may be coupled with a PCRF 526 via a Gx reference point.

**[0076]** PCRF 526 is the policy and charging control element of the EPC 520. In a non-roaming scenario, there may be a single PCRF 526 in the Home Public Land Mobile Network (HPLMN) associated with a UE 501's Internet Protocol Connectivity Access Network (IP-CAN) session. In a roaming scenario with local breakout of traffic, there may be two PCRFs associated with a UE 501's IP-CAN session, a Home PCRF (H-PCRF) within an HPLMN and a Visited PCRF (V-PCRF) within a Visited Public Land Mobile Network (VPLMN). The PCRF 526 may be communicatively coupled to the application server 530 via the P-GW 523. The application server 530 may signal the PCRF 526 to indicate a new service flow and select the appropriate QoS and charging parameters. The PCRF 526 may provision this rule into a PCEF (not shown) with the appropriate TFT and QCI, which commences the QoS and charging as specified by the application server 530. The Gx reference point between the PCRF 526 and the P-GW 523 may allow for the transfer of QoS policy and charging rules from the PCRF 526 to PCEF in the P-GW 523. An Rx reference point may reside between the PDN 530 (or "AF 530") and the PCRF 526.

**[0077]** FIG. 6 illustrates an architecture of a system 600 including a second CN 620 in accordance with various embodiments. The system 600 is shown to include a UE 601, which may be the same or similar to the UEs 401 and UE 501 discussed previously; a (R)AN 610, which may be the same or similar to the RAN 410 and RAN 510 discussed previously, and which can include RAN nodes 411 discussed previously; and a data network (DN) 603, which may be, for example, operator services, Internet access or 3rd party services; and a 5GC 620. The 5GC 620 can include an Authentication Server Function (AUSF) 622; an Access and Mobility Management Function (AMF) 621; a Session Management Function (SMF) 624; a Network Exposure Function (NEF) 623; a PCF 626; a NF Repository Function (NRF) 625; a UDM 627; an Application Function (AF) 628; a User Plane Function (UPF) 602; and a Network Slice Selection Function (NSSF) 629.

- [0078]** The UPF 602 may act as an anchor point for intra-RAT and inter-RAT mobility, an external PDU session point of interconnect to DN 603, and a branching point to support multi-homed PDU session. The UPF 602 may also perform packet routing and forwarding, perform packet inspection, enforce the user plane part of policy rules, lawfully intercept packets (UP collection), perform traffic usage reporting, perform QoS handling for a user plane (e.g., packet filtering, gating, UL/DL rate enforcement), perform Uplink Traffic verification (e.g., SDF to QoS flow mapping), transport level packet marking in the uplink and downlink, and perform downlink packet buffering and downlink data notification triggering. UPF 602 can include an uplink classifier to support routing traffic flows to a data network. The DN 603 may represent various network operator services, Internet access, or third party services. DN 603 can include, or be similar to, application server 430 discussed previously. The UPF 602 interacts with the SMF 624 via an N4 reference point between the SMF 624 and the UPF 602.
- [0079]** The AUSF 622 stores data for authentication of UE 601 and handle authentication-related functionality. The AUSF 622 may facilitate a common authentication framework for various access types. The AUSF 622 communicate with the AMF 621 via an N12 reference point between the AMF 621 and the AUSF 622; and communicate with the UDM 627 via an N13 reference point between the UDM 627 and the AUSF 622. Additionally, the AUSF 622 can exhibit an Nausf service-based interface.
- [0080]** The AMF 621 may be responsible for registration management (e.g., for registering UE 601, etc.), connection management, reachability management, mobility management, and lawful interception of AMF-related events, and access authentication and authorization. The AMF 621 may be a termination point for the N11 reference point between the AMF 621 and the SMF 624. The AMF 621 provides transport for Session Management (SM) messages between the UE 601 and the SMF 624, and act as a transparent proxy for routing SM messages. AMF 621 may also provide transport for Short Message Service (SMS) messages between UE 601 and an SMS Function (SMSF) (not illustrated in FIG. 6). AMF 621 may act as a Security Anchor Function (SEAF), which can include interaction with the AUSF 622 and the UE 601, receipt of an intermediate key that was established as a result of the UE 601 authentication process. Where Universal Subscriber Identity Module (USIM) based authentication is used, the AMF 621 may retrieve the security material from the AUSF 622. AMF 621 may also

- 22 -

include a Security Context Management (SCM) function, which receives a key from the SEA that it uses to derive access-network specific keys. Furthermore, AMF 621 may be a termination point of a RAN CP interface, which can include or be an N2 reference point between the (R)AN 610 and the AMF 621; and the AMF 621 may be a termination point of NAS (N1) signalling, and perform NAS ciphering and integrity protection.

**[0081]** AMF 621 may also support NAS signalling with a UE 601 over an N3 IWF interface. The N3IWF may be used to provide access to untrusted entities. N3IWF may be a termination point for the N2 interface between the (R)AN 610 and the AMF 621 for the control plane, and may be a termination point for the N3 reference point between the (R)AN 610 and the UPF 602 for the user plane. As such, the AMF 621 handles N2 signalling from the SMF 624 and the AMF 621 for Protocol Data Unit (PDU) sessions and QoS, encapsulate/de-encapsulate packets for IPsec and N3 tunnelling, mark N3 user-plane packets in the uplink, and enforce QoS corresponding to N3 packet marking taking into account QoS requirements associated with such marking received over N2. N3IWF may also relay uplink and downlink control-plane NAS signalling between the UE 601 and AMF 621 via an N1 reference point between the UE 601 and the AMF 621, and relay uplink and downlink user-plane packets between the UE 601 and UPF 602. The N3IWF also provides mechanisms for IPsec tunnel establishment with the UE 601. The AMF 621 can exhibit an Namf service-based interface, and may be a termination point for an N14 reference point between two AMFs 621 and an N17 reference point between the AMF 621 and a 5G-EIR (not illustrated in FIG. 6).

**[0082]** The UE 601 may need to register with the AMF 621 in order to receive network services. Registration Management (RM) is used to register or deregister the UE 601 with the network (e.g., AMF 621), and establish a UE context in the network (e.g., AMF 621). The UE 601 may operate in an RM-REGISTERED state or an RM-DEREGISTERED state. In the RM-DEREGISTERED state, the UE 601 is not registered with the network, and the UE context in AMF 621 holds no valid location or routing information for the UE 601 so the UE 601 is not reachable by the AMF 621. In the RM-REGISTERED state, the UE 601 is registered with the network, and the UE context in AMF 621 may hold a valid location or routing information for the UE 601 so the UE 601 is reachable by the AMF 621. In the RM-REGISTERED state, the UE 601 may perform mobility Registration Update procedures, perform periodic Registration Update procedures triggered by

expiration of the periodic update timer (e.g., to notify the network that the UE 601 is still active), and perform a Registration Update procedure to update UE capability information or to re-negotiate protocol parameters with the network, among others.

**[0083]** The AMF 621 stores one or more RM contexts for the UE 601, where each RM context is associated with a specific access to the network. The RM context may be a data structure, database object, etc. that indicates or stores, inter alia, a registration state per access type and the periodic update timer. The AMF 621 may also store a 5GC Mobility Management (MM) context that may be the same or similar to the (E)MM context discussed previously. In various embodiments, the AMF 621 stores a CE mode B Restriction parameter of the UE 601 in an associated MM context or RM context. The AMF 621 may also derive the value, when needed, from the UE's usage setting parameter already stored in the UE context (and/or MM/RM context).

**[0084]** Connection Management (CM) establishes and releases a signaling connection between the UE 601 and the AMF 621 over the N1 interface. The signaling connection is used to enable NAS signaling exchange between the UE 601 and the CN 620, and comprises both the signaling connection between the UE and the AN (e.g., Radio Resource Control (RRC) connection or UE-N3IWF connection for non-3GPP access) and the N2 connection for the UE 601 between the AN (e.g., RAN 610) and the AMF 621. The UE 601 may operate in one of two CM states, CM-IDLE mode or CM-CONNECTED mode. When the UE 601 is operating in the CM-IDLE state/mode, the UE 601 may have no Non-Access Stratum (NAS) signaling connection established with the AMF 621 over the N1 interface, and there may be (R)AN 610 signaling connection (e.g., N2 and/or N3 connections) for the UE 601. When the UE 601 is operating in the CM-CONNECTED state/mode, the UE 601 may have an established NAS signaling connection with the AMF 621 over the N1 interface, and there may be a (R)AN 610 signaling connection (e.g., N2 and/or N3 connections) for the UE 601. Establishment of an N2 connection between the (R)AN 610 and the AMF 621 may cause the UE 601 to transition from CM-IDLE mode to CM-CONNECTED mode, and the UE 601 may transition from the CM-CONNECTED mode to the CM-IDLE mode when N2 signaling between the (R)AN 610 and the AMF 621 is released.

**[0085]** The SMF 624 is responsible for Session Management (SM) (e.g., session establishment, modify and release, including tunnel maintain between UPF and AN

- 24 -

node); UE IP address allocation and management (including optional authorization); selection and control of User Plane (UP) function; configuring traffic steering at UPF to route traffic to proper destination; termination of interfaces toward policy control functions; controlling part of policy enforcement and QoS; lawful intercept (for SM events and interface to LI system); termination of SM parts of NAS messages; downlink data notification; initiating AN specific SM information, sent via Access and Mobility Management Function (AMF) over N2 to AN; and determining Session and Service Continuity (SSC) mode of a session. SM may refer to management of a Protocol Data Unit (PDU) session, and a PDU session or “session” may refer to a PDU connectivity service that provides or enables the exchange of PDUs between a UE 601 and a data network (DN) 603 identified by a Data Network Name (DNN). PDU sessions may be established upon UE 601 request, modified upon UE 601 and 5GC 620 request, and released upon UE 601 and 5GC 620 request using NAS SM signaling exchanged over the N1 reference point between the UE 601 and the SMF 624. Upon request from an application server, the 5GC 620 may trigger a specific application in the UE 601. In response to receipt of the trigger message, the UE 601 may pass the trigger message (or relevant parts/information of the trigger message) to one or more identified applications in the UE 601. The identified application(s) in the UE 601 may establish a PDU session to a specific DNN. The SMF 624 may check whether the UE 601 requests are compliant with user subscription information associated with the UE 601. In this regard, the SMF 624 may retrieve and/or request to receive update notifications on SMF 624 level subscription data from the UDM 627.

- [0086]** The SMF 624 can include the following roaming functionality: handling local enforcement to apply QoS SLAs (VPLMN); charging data collection and charging interface (VPLMN); lawful intercept (in VPLMN for SM events and interface to LI system); and support for interaction with external DN for transport of signalling for PDU session authorization/authentication by external DN. An N16 reference point between two SMFs 624 may be included in the system 600, which may be between another SMF 624 in a visited network and the SMF 624 in the home network in roaming scenarios. Additionally, the SMF 624 can exhibit the Nsmf service-based interface.
- [0087]** The NEF 623 provides means for securely exposing the services and capabilities provided by 3GPP network functions for third party, internal exposure/re-exposure,

Application Functions (e.g., AF 628), edge computing or fog computing systems, etc. In such embodiments, the NEF 623 may authenticate, authorize, and/or throttle the AFs. NEF 623 may also translate information exchanged with the AF 628 and information exchanged with internal network functions. For example, the NEF 623 may translate between an AF-Service-Identifier and an internal 5GC information. NEF 623 may also receive information from other network functions (NFs) based on exposed capabilities of other network functions. This information may be stored at the NEF 623 as structured data, or at a data storage NF using standardized interfaces. The stored information can then be re-exposed by the NEF 623 to other NFs and AFs, and/or used for other purposes such as analytics. Additionally, the NEF 623 can exhibit an Nnef service-based interface.

**[0088]** The NRF 625 supports service discovery functions, receive Network Function (NF) discovery requests from NF instances, and provide the information of the discovered NF instances to the NF instances. NRF 625 also maintains information of available NF instances and their supported services. As used herein, the terms “instantiate,” “instantiation,” and the like may refer to the creation of an instance, and an “instance” may refer to a concrete occurrence of an object, which may occur, for example, during execution of program code. Additionally, the NRF 625 can exhibit the Nnrf service-based interface.

**[0089]** The PCF 626 provides policy rules to control plane function(s) to enforce them, and may also support unified policy framework to govern network behaviour. The PCF 626 may also implement a Front End (FE) to access subscription information relevant for policy decisions in a UDR of the UDM 627. The PCF 626 communicate with the AMF 621 via an N15 reference point between the PCF 626 and the AMF 621, which can include a PCF 626 in a visited network and the AMF 621 in case of roaming scenarios. The PCF 626 communicate with the AF 628 via an N5 reference point between the PCF 626 and the AF 628; and with the SMF 624 via an N7 reference point between the PCF 626 and the SMF 624. The system 600 and/or CN 620 may also include an N24 reference point between the PCF 626 (in the home network) and a PCF 626 in a visited network. Additionally, the PCF 626 can exhibit an Npcf service-based interface.

**[0090]** The UDM 627 handles subscription-related information to support the network entities' handling of communication sessions, and stores subscription data of UE 601. For example, subscription data may be communicated between the UDM 627 and the AMF

- 26 -

621 via an N8 reference point between the UDM 627 and the AMF. The UDM 627 can include two parts, an application Front End (FE) and a UDR (the FE and UDR are not illustrated in FIG. 6). The UDR stores subscription data and policy data for the UDM 627 and the PCF 626, and/or structured data for exposure and application data (including PFDs for application detection, application request information for multiple UEs 601) for the NEF 623. The Nudr service-based interface may be exhibited by the UDR 221 to allow the UDM 627, PCF 626, and NEF 623 to access a particular set of the stored data, as well as to read, update (e.g., add, modify), delete, and subscribe to notification of relevant data changes in the UDR. The UDM can include a UDM-FE, which is in charge of processing credentials, location management, subscription management and so on. Several different front ends can serve the same user in different transactions. The UDM-FE accesses subscription information stored in the UDR and performs authentication credential processing, user identification handling, access authorization, registration/mobility management, and subscription management. The UDR interacts with the SMF 624 via an N10 reference point between the UDM 627 and the SMF 624. UDM 627 may also support SMS management, wherein an SMS-FE implements the similar application logic as discussed previously. Additionally, the UDM 627 can exhibit the Nudm service-based interface.

**[0091]** The AF 628 provides application influence on traffic routing, provide access to the NCE, and interact with the policy framework for policy control. The NCE is a mechanism that allows the 5GC 620 and AF 628 to provide information to each other via NEF 623, which may be used for edge computing implementations. In such implementations, the network operator and third party services can be hosted close to the UE 601 access point of attachment to achieve an efficient service delivery through the reduced end-to-end latency and load on the transport network. For edge computing implementations, the 5GC can select a UPF 602 close to the UE 601 and execute traffic steering from the UPF 602 to DN 603 via the N6 interface. This may be based on the UE subscription data, UE location, and information provided by the AF 628. In this way, the AF 628 influences UPF (re)selection and traffic routing. Based on operator deployment, when AF 628 is considered to be a trusted entity, the network operator permits AF 628 to interact directly with relevant NFs. Additionally, the AF 628 can exhibit an Naf service-based interface.

- [0092] The NSSF 629 selects a set of network slice instances serving the UE 601. The NSSF 629 also determines allowed Network Slice Selection Assistance Information (NSSAI) and the mapping to the subscribed Single-NSSAIs (S-NSSAIs), if needed. The NSSF 629 also determines the Access and Mobility Management Function (AMF) set to be used to serve the UE 601, or a list of candidate AMF(s) 621 based on a suitable configuration and possibly by querying the NRF 625. The selection of a set of network slice instances for the UE 601 may be triggered by the AMF 621 with which the UE 601 is registered by interacting with the NSSF 629, which may lead to a change of AMF 621. The NSSF 629 interacts with the AMF 621 via an N22 reference point between AMF 621 and NSSF 629; and communicate with another NSSF 629 in a visited network via an N31 reference point (not illustrated in FIG. 6). Additionally, the NSSF 629 can exhibit an Nnssf service-based interface.
- [0093] As discussed previously, the CN 620 can include an SMS Function (SMSF), which may be responsible for Short Message Service (SMS) subscription checking and verification, and relaying SM messages to/from the UE 601 to/from other entities, such as an SMS-GMSC/IW MSC/SMS-router. The SMS also interacts with AMF 621 and UDM 627 for a notification procedure that the UE 601 is available for SMS transfer (e.g., set a UE not reachable flag, and notifying UDM 627 when UE 601 is available for SMS).
- [0094] The CN 620 may also include other elements that are not illustrated in FIG. 6, such as a Data Storage system/architecture, a 5G- Equipment Identity Register (EIR), a Security Edge Protection Pro15 (SEPP), and the like. The Data Storage system can include a Structured Data Storage Function (SDSF), an Unstructured Data Storage Network Function (UDSF), and/or the like. Any Network Function (NF) stores and retrieve unstructured data into/from the UDSF (e.g., UE contexts), via N18 reference point between any NF and the UDSF (not illustrated in FIG. 6). Individual NFs may share a UDSF for storing their respective unstructured data or individual NFs may each have their own UDSF located at or near the individual NFs. Additionally, the UDSF can exhibit an Nudsf service-based interface (not illustrated in FIG. 6). The 5G-EIR may be an NF that checks the status of PEI for determining whether particular equipment/entities are blacklisted from the network; and the SEPP may be a non-transparent pro15 that performs topology hiding, message filtering, and policing on inter- Public Land Mobile Network (PLMN) control plane interfaces.

[0095] Additionally, there may be many more reference points and/or service-based interfaces between the NF services in the NFs; however, these interfaces and reference points have been omitted from FIG. 6 for clarity. In one example, the CN 620 can include an Nx interface, which is an inter-CN interface between the MME (e.g., MME 521) and the AMF 621 in order to enable interworking between CN 620 and CN 520. Other example interfaces/reference points can include an N5g-EIR service-based interface exhibited by a 5G-EIR, an N27 reference point between the NF Repository Function (NRF) in the visited network and the NRF in the home network; and an N31 reference point between the Network Slice Selection Function (NSSF) in the visited network and the NSSF in the home network.

#### Exemplary Infrastructure Equipment

[0096] FIG. 7 illustrates an example of infrastructure equipment 700 in accordance with various embodiments. The infrastructure equipment 700 (or “system 700”) can be implemented as a base station, radio head, RAN node such as the RAN nodes 411 and/or AP 406 shown and described previously, application server(s) 430, and/or any other element/device discussed herein. In other examples, the system 700 could be implemented in or by a UE.

[0097] The system 700 includes application circuitry 705, baseband circuitry 710, one or more radio front end modules (RFEMs) 715, memory circuitry 720, power management integrated circuitry (PMIC) 725, power tee circuitry 730, network controller circuitry 735, network interface connector 740, satellite positioning circuitry 745, and user interface 750. In some embodiments, the device 700 can include additional elements such as, for example, memory/storage, display, camera, sensor, or input/output (I/O) interface. In other embodiments, the components described below may be included in more than one device. For example, said circuitries may be separately included in more than one device for Cloud Radio Access Network (CRAN), vBBU, or other like implementations.

[0098] Application circuitry 705 includes circuitry such as, but not limited to one or more processors (or processor cores), cache memory, and one or more of low drop-out voltage regulators (LDOs), interrupt controllers, serial interfaces such as SPI, I<sup>2</sup>C or universal programmable serial interface module, real time clock (RTC), timer-counters including interval and watchdog timers, general purpose input/output (I/O or IO), memory card controllers such as Secure Digital (SD) MultiMediaCard (MMC) or similar, Universal

Serial Bus (USB) interfaces, Mobile Industry Processor Interface (MIPI) interfaces and Joint Test Access Group (JTAG) test access ports. The processors (or cores) of the application circuitry 705 may be coupled with or can include memory/storage elements and can be configured to execute instructions stored in the memory/storage to enable various applications or operating systems to run on the system 700. In some embodiments, the memory/storage elements may be on-chip memory circuitry, which can include any suitable volatile and/or non-volatile memory, such as DRAM, SRAM, EPROM, EEPROM, Flash memory, solid-state memory, and/or any other type of memory device technology, such as those discussed herein.

**[0099]** The processor(s) of application circuitry 705 can include, for example, one or more processor cores (CPUs), one or more application processors, one or more graphics processing units (GPUs), one or more reduced instruction set computing (RISC) processors, one or more Acorn RISC Machine (ARM) processors, one or more complex instruction set computing (CISC) processors, one or more digital signal processors (DSP), one or more FPGAs, one or more PLDs, one or more ASICs, one or more microprocessors or controllers, or any suitable combination thereof. In some embodiments, the application circuitry 705 may comprise, or may be, a special-purpose processor/controller to operate according to the various embodiments herein. As examples, the processor(s) of application circuitry 705 can include one or more Intel Pentium®, Core®, or Xeon® processor(s); Advanced Micro Devices (AMD) Ryzen® processor(s), Accelerated Processing Units (APUs), or Epyc® processors; ARM-based processor(s) licensed from ARM Holdings, Ltd. such as the ARM Cortex-A family of processors and the ThunderX2® provided by Cavium(TM), Inc.; a MIPS-based design from MIPS Technologies, Inc. such as MIPS Warrior P-class processors; and/or the like. In some embodiments, the system 700 may not utilize application circuitry 705, and instead can include a special-purpose processor/controller to process IP data received from an EPC or 5GC, for example.

**[0100]** In some embodiments, the application circuitry 705 can include one or more hardware accelerators, which may be microprocessors, programmable processing devices, or the like. The one or more hardware accelerators can include, for example, computer vision (CV) and/or deep learning (DL) accelerators. As examples, the programmable processing devices may be one or more a field-programmable devices (FPDs) such as

field-programmable gate arrays (FPGAs) and the like; programmable logic devices (PLDs) such as complex PLDs (CPLDs), high-capacity PLDs (HCPLDs), and the like; ASICs such as structured ASICs and the like; programmable SoCs (PSoCs); and the like. In such implementations, the circuitry of application circuitry 705 may comprise logic blocks or logic fabric, and other interconnected resources that may be programmed to perform various functions, such as the procedures, methods, functions, etc. of the various embodiments discussed herein. In such embodiments, the circuitry of application circuitry 705 can include memory cells (e.g., erasable programmable read-only memory (EPROM), electrically erasable programmable read-only memory (EEPROM), flash memory, static memory (e.g., static random access memory (SRAM), anti-fuses, etc.)) used to store logic blocks, logic fabric, data, etc. in look-up-tables (LUTs) and the like.

**[0101]** The baseband circuitry 710 can be implemented, for example, as a solder-down substrate including one or more integrated circuits, a single packaged integrated circuit soldered to a main circuit board or a multi-chip module containing two or more integrated circuits. The various hardware electronic elements of baseband circuitry 710 are to be discussed below with regard to FIG. 9.

**[0102]** User interface circuitry 750 can include one or more user interfaces designed to enable user interaction with the system 700 or peripheral component interfaces designed to enable peripheral component interaction with the system 700. User interfaces can include, but are not limited to, one or more physical or virtual buttons (e.g., a reset button), one or more indicators (e.g., light emitting diodes (LEDs)), a physical keyboard or keypad, a mouse, a touchpad, a touchscreen, speakers or other audio emitting devices, microphones, a printer, a scanner, a headset, a display screen or display device, etc. Peripheral component interfaces can include, but are not limited to, a nonvolatile memory port, a universal serial bus (USB) port, an audio jack, a power supply interface, etc.

**[0103]** The radio front end modules (RFEMs) 715 may comprise a millimeter wave (mmWave) RFEM and one or more sub-mmWave radio frequency integrated circuits (RFICs). In some embodiments, the one or more sub-mmWave RFICs may be physically separated from the mmWave RFEM. The RFICs can include connections to one or more antennas or antenna arrays (see e.g., antenna array 911 of FIG. 9 infra), and the RFEM may be connected to multiple antennas. In alternative implementations, both mmWave

and sub-mmWave radio functions can be implemented in the same physical RFEM 715, which incorporates both mmWave antennas and sub-mmWave.

- [0104]** The memory circuitry 720 can include one or more of volatile memory including dynamic random access memory (DRAM) and/or synchronous dynamic random access memory (SDRAM), and nonvolatile memory (NVM) including high-speed electrically erasable memory (commonly referred to as Flash memory), phase change random access memory (PRAM), magnetoresistive random access memory (MRAM), etc., and may incorporate the three-dimensional (3D) cross-point (XPOINT) memories from Intel® and Micron®. Memory circuitry 720 can be implemented as one or more of solder down packaged integrated circuits, socketed memory modules and plug-in memory cards.
- [0105]** The PMIC 725 can include voltage regulators, surge protectors, power alarm detection circuitry, and one or more backup power sources such as a battery or capacitor. The power alarm detection circuitry may detect one or more of brown out (under-voltage) and surge (over-voltage) conditions. The power tee circuitry 730 provides for electrical power drawn from a network cable to provide both power supply and data connectivity to the infrastructure equipment 700 using a single cable.
- [0106]** The network controller circuitry 735 provides connectivity to a network using a standard network interface protocol such as Ethernet, Ethernet over GRE Tunnels, Ethernet over Multiprotocol Label Switching (MPLS), or some other suitable protocol. Network connectivity may be provided to/from the infrastructure equipment 700 via network interface connector 740 using a physical connection, which may be electrical (commonly referred to as a “copper interconnect”), optical, or wireless. The network controller circuitry 735 can include one or more dedicated processors and/or FPGAs to communicate using one or more of the aforementioned protocols. In some embodiments, the network controller circuitry 735 can include multiple controllers to provide connectivity to other networks using the same or different protocols.
- [0107]** The positioning circuitry 745 includes circuitry to receive and decode signals transmitted/broadcasted by a positioning network of a global navigation satellite system (GNSS). Examples of navigation satellite constellations (or GNSS) include United States’ Global Positioning System (GPS), Russia’s Global Navigation System (GLONASS), the European Union’s Galileo system, China’s BeiDou Navigation Satellite System, a regional navigation system or GNSS augmentation system (e.g., Navigation with Indian

Constellation (NAVIC), Japan's Quasi-Zenith Satellite System (QZSS), France's Doppler Orbitography and Radio-positioning Integrated by Satellite (DORIS), etc.), or the like. The positioning circuitry 745 comprises various hardware elements (e.g., including hardware devices such as switches, filters, amplifiers, antenna elements, and the like to facilitate OTA communications) to communicate with components of a positioning network, such as navigation satellite constellation nodes. In some embodiments, the positioning circuitry 745 can include a Micro-Technology for Positioning, Navigation, and Timing (Micro-PNT) IC that uses a master timing clock to perform position tracking/estimation without GNSS assistance. The positioning circuitry 745 may also be part of, or interact with, the baseband circuitry 710 and/or RFEMs 715 to communicate with the nodes and components of the positioning network. The positioning circuitry 745 may also provide position data and/or time data to the application circuitry 705, which may use the data to synchronize operations with various infrastructure (e.g., RAN nodes 411, etc.), or the like.

**[0108]** The components illustrated in FIG. 7 communicate with one another using interface circuitry, which can include any number of bus and/or interconnect (IX) technologies such as industry standard architecture (ISA), extended ISA (EISA), peripheral component interconnect (PCI), peripheral component interconnect extended (PCIx), PCI express (PCIe), or any number of other technologies. The bus/IX may be a proprietary bus, for example, used in a System on Chip (SoC) based system. Other bus/IX systems may be included, such as an I<sup>2</sup>C interface, an SPI interface, point to point interfaces, and a power bus, among others.

**[0109]** FIG. 8 illustrates an example of a platform 800 (or "device 800") in accordance with various embodiments. In some embodiments, the computer platform 800 may be suitable for use as UEs 401, 501, application servers 430, and/or any other element/device discussed herein. The platform 800 can include any combinations of the components shown in the example. The components of platform 800 can be implemented as integrated circuits (ICs), portions thereof, discrete electronic devices, or other modules, logic, hardware, software, firmware, or a combination thereof adapted in the computer platform 800, or as components otherwise incorporated within a chassis of a larger system. The block diagram of FIG. 8 is intended to show a high level view of components of the computer platform 800. However, some of the components shown may be omitted,

additional components may be present, and different arrangement of the components shown may occur in other implementations.

**[0110]** Application circuitry 805 includes circuitry such as, but not limited to one or more processors (or processor cores), cache memory, and one or more of LDOs, interrupt controllers, serial interfaces such as SPI, I<sup>2</sup>C or universal programmable serial interface module, RTC, timer-counters including interval and watchdog timers, general purpose I/O, memory card controllers such as SD MMC or similar, USB interfaces, MIPI interfaces, and JTAG test access ports. The processors (or cores) of the application circuitry 805 may be coupled with or can include memory/storage elements and can be configured to execute instructions stored in the memory/storage to enable various applications or operating systems to run on the system 800. In some embodiments, the memory/storage elements may be on-chip memory circuitry, which can include any suitable volatile and/or non-volatile memory, such as DRAM, SRAM, EPROM, EEPROM, Flash memory, solid-state memory, and/or any other type of memory device technology, such as those discussed herein.

**[0111]** The processor(s) of application circuitry 805 can include, for example, one or more processor cores, one or more application processors, one or more GPUs, one or more RISC processors, one or more ARM processors, one or more CISC processors, one or more DSP, one or more FPGAs, one or more PLDs, one or more ASICs, one or more microprocessors or controllers, a multithreaded processor, an ultra-low voltage processor, an embedded processor, some other known processing element, or any suitable combination thereof. In some embodiments, the application circuitry 805 may comprise, or may be, a special-purpose processor/controller to operate according to the various embodiments herein.

**[0112]** As examples, the processor(s) of application circuitry 805 can include an Intel® Architecture Core™ based processor, such as a Quark™, an Atom™, an i3, an i5, an i7, or an MCU-class processor, or another such processor available from Intel® Corporation, Santa Clara, CA. The processors of the application circuitry 805 may also be one or more of Advanced Micro Devices (AMD) Ryzen® processor(s) or Accelerated Processing Units (APUs); A5-A9 processor(s) from Apple® Inc., Snapdragon™ processor(s) from Qualcomm® Technologies, Inc., Texas Instruments, Inc.® Open Multimedia Applications Platform (OMAP)™ processor(s); a MIPS-based design from MIPS

Technologies, Inc. such as MIPS Warrior M-class, Warrior I-class, and Warrior P-class processors; an ARM-based design licensed from ARM Holdings, Ltd., such as the ARM Cortex-A, Cortex-R, and Cortex-M family of processors; or the like. In some embodiments, the application circuitry 805 may be a part of a system on a chip (SoC) in which the application circuitry 805 and other components are formed into a single integrated circuit, or a single package, such as the Edison™ or Galileo™ SoC boards from Intel® Corporation.

- [0113] Additionally or alternatively, application circuitry 805 can include circuitry such as, but not limited to, one or more a field-programmable devices (FPDs) such as FPGAs and the like; programmable logic devices (PLDs) such as complex PLDs (CPLDs), high-capacity PLDs (HCPLDs), and the like; ASICs such as structured ASICs and the like; programmable SoCs (PSoCs); and the like. In such embodiments, the circuitry of application circuitry 805 may comprise logic blocks or logic fabric, and other interconnected resources that may be programmed to perform various functions, such as the procedures, methods, functions, etc. of the various embodiments discussed herein. In such embodiments, the circuitry of application circuitry 805 can include memory cells (e.g., erasable programmable read-only memory (EPROM), electrically erasable programmable read-only memory (EEPROM), flash memory, static memory (e.g., static random access memory (SRAM), anti-fuses, etc.)) used to store logic blocks, logic fabric, data, etc. in look-up tables (LUTs) and the like.
- [0114] The baseband circuitry 810 can be implemented, for example, as a solder-down substrate including one or more integrated circuits, a single packaged integrated circuit soldered to a main circuit board or a multi-chip module containing two or more integrated circuits. The various hardware electronic elements of baseband circuitry 810 are discussed *infra* with regard to FIG. 9.
- [0115] The RFEMs 815 may comprise a millimeter wave (mmWave) RFEM and one or more sub-mmWave radio frequency integrated circuits (RFICs). In some embodiments, the one or more sub-mmWave RFICs may be physically separated from the mmWave RFEM. The RFICs can include connections to one or more antennas or antenna arrays (see e.g., antenna array 911 of FIG. 9 *infra*), and the RFEM may be connected to multiple antennas. In alternative implementations, both mmWave and sub-mmWave radio

functions can be implemented in the same physical RFEM 815, which incorporates both mmWave antennas and sub-mmWave.

**[0116]** The memory circuitry 820 can include any number and type of memory devices used to provide for a given amount of system memory. As examples, the memory circuitry 820 can include one or more of volatile memory including random access memory (RAM), dynamic RAM (DRAM) and/or synchronous dynamic RAM (SDRAM), and nonvolatile memory (NVM) including high-speed electrically erasable memory (commonly referred to as Flash memory), phase change random access memory (PRAM), magnetoresistive random access memory (MRAM), etc. The memory circuitry 820 may be developed in accordance with a Joint Electron Devices Engineering Council (JEDEC) low power double data rate (LPDDR)-based design, such as LPDDR2, LPDDR3, LPDDR4, or the like. Memory circuitry 820 can be implemented as one or more of solder down packaged integrated circuits, single die package (SDP), dual die package (DDP) or quad die package (Q17P), socketed memory modules, dual inline memory modules (DIMMs) including microDIMMs or MiniDIMMs, and/or soldered onto a motherboard via a ball grid array (BGA). In low power implementations, the memory circuitry 820 may be on-die memory or registers associated with the application circuitry 805. To provide for persistent storage of information such as data, applications, operating systems and so forth, memory circuitry 820 can include one or more mass storage devices, which can include, inter alia, a solid state disk drive (SSDD), hard disk drive (HDD), a micro HDD, resistance change memories, phase change memories, holographic memories, or chemical memories, among others. For example, the computer platform 800 may incorporate the three-dimensional (3D) cross-point (XPOINT) memories from Intel® and Micron®.

**[0117]** Removable memory circuitry 823 can include devices, circuitry, enclosures/housings, ports or receptacles, etc. used to couple portable data storage devices with the platform 800. These portable data storage devices may be used for mass storage purposes, and can include, for example, flash memory cards (e.g., Secure Digital (SD) cards, microSD cards, xD picture cards, and the like), and USB flash drives, optical discs, external HDDs, and the like.

**[0118]** The platform 800 can also include interface circuitry (not shown) that is used to connect external devices with the platform 800. The external devices connected to the

platform 800 via the interface circuitry include sensor circuitry 821 and electro-mechanical components (EMCs) 822, as well as removable memory devices coupled to removable memory circuitry 823.

**[0119]** The sensor circuitry 821 includes devices, modules, or subsystems whose purpose is to detect events or changes in its environment and send the information (sensor data) about the detected events to some other a device, module, subsystem, etc. Examples of such sensors include, inter alia, inertia measurement units (IMUs) comprising accelerometers, gyroscopes, and/or magnetometers; microelectromechanical systems (MEMS) or nanoelectromechanical systems (NEMS) comprising 3-axis accelerometers, 3-axis gyroscopes, and/or magnetometers; level sensors; flow sensors; temperature sensors (e.g., thermistors); pressure sensors; barometric pressure sensors; gravimeters; altimeters; image capture devices (e.g., cameras or lensless apertures); light detection and ranging (LiDAR) sensors; proximity sensors (e.g., infrared radiation detector and the like), depth sensors, ambient light sensors, ultrasonic transceivers; microphones or other like audio capture devices; etc.

**[0120]** EMCs 822 include devices, modules, or subsystems whose purpose is to enable platform 800 to change its state, position, and/or orientation, or move or control a mechanism or (sub)system. Additionally, EMCs 822 can be configured to generate and send messages/signalling to other components of the platform 800 to indicate a current state of the EMCs 822. Examples of the EMCs 822 include one or more power switches, relays including electromechanical relays (EMRs) and/or solid state relays (SSRs), actuators (e.g., valve actuators, etc.), an audible sound generator, a visual warning device, motors (e.g., DC motors, stepper motors, etc.), wheels, thrusters, propellers, claws, clamps, hooks, and/or other like electro-mechanical components. In some embodiments, platform 800 is configured to operate one or more EMCs 822 based on one or more captured events and/or instructions or control signals received from a service provider and/or various clients.

**[0121]** In some embodiments, the interface circuitry connects the platform 800 with positioning circuitry 845. The positioning circuitry 845 includes circuitry to receive and decode signals transmitted/broadcasted by a positioning network of a GNSS. Examples of navigation satellite constellations (or GNSS) include United States' GPS, Russia's GLONASS, the European Union's Galileo system, China's BeiDou Navigation Satellite

System, a regional navigation system or GNSS augmentation system (e.g., NAVIC), Japan's QZSS, France's DORIS, etc.), or the like. The positioning circuitry 845 comprises various hardware elements (e.g., including hardware devices such as switches, filters, amplifiers, antenna elements, and the like to facilitate OTA communications) to communicate with components of a positioning network, such as navigation satellite constellation nodes. In some embodiments, the positioning circuitry 845 can include a Micro-PNT IC that uses a master timing clock to perform position tracking/estimation without GNSS assistance. The positioning circuitry 845 may also be part of, or interact with, the baseband circuitry 810 and/or RFEMs 815 to communicate with the nodes and components of the positioning network. The positioning circuitry 845 may also provide position data and/or time data to the application circuitry 805, which may use the data to synchronize operations with various infrastructure (e.g., radio base stations), for turn-by-turn navigation applications, or the like

**[0122]** In some embodiments, the interface circuitry connects the platform 800 with Near-Field Communication (NFC) circuitry 840. NFC circuitry 840 is configured to provide contactless, short-range communications based on radio frequency identification (RFID) standards, wherein magnetic field induction is used to enable communication between NFC circuitry 840 and NFC-enabled devices external to the platform 800 (e.g., an "NFC touchpoint"). NFC circuitry 840 comprises an NFC controller coupled with an antenna element and a processor coupled with the NFC controller. The NFC controller may be a chip/IC providing NFC functionalities to the NFC circuitry 840 by executing NFC controller firmware and an NFC stack. The NFC stack may be executed by the processor to control the NFC controller, and the NFC controller firmware may be executed by the NFC controller to control the antenna element to emit short-range RF signals. The RF signals may power a passive NFC tag (e.g., a microchip embedded in a sticker or wristband) to transmit stored data to the NFC circuitry 840, or initiate data transfer between the NFC circuitry 840 and another active NFC device (e.g., a smartphone or an NFC-enabled POS terminal) that is proximate to the platform 800.

**[0123]** The driver circuitry 846 can include software and hardware elements that operate to control particular devices that are embedded in the platform 800, attached to the platform 800, or otherwise communicatively coupled with the platform 800. The driver circuitry 846 can include individual drivers allowing other components of the platform

800 to interact with or control various input/output (I/O) devices that may be present within, or connected to, the platform 800. For example, driver circuitry 846 can include a display driver to control and allow access to a display device, a touchscreen driver to control and allow access to a touchscreen interface of the platform 800, sensor drivers to obtain sensor readings of sensor circuitry 821 and control and allow access to sensor circuitry 821, EMC drivers to obtain actuator positions of the EMCs 822 and/or control and allow access to the EMCs 822, a camera driver to control and allow access to an embedded image capture device, audio drivers to control and allow access to one or more audio devices.

**[0124]** The power management integrated circuitry (PMIC) 825 (also referred to as “power management circuitry 825”) may manage power provided to various components of the platform 800. In particular, with respect to the baseband circuitry 810, the PMIC 825 may control power-source selection, voltage scaling, battery charging, or DC-to-DC conversion. The PMIC 825 may often be included when the platform 800 is capable of being powered by a battery 830, for example, when the device is included in a UE 401, 501.

**[0125]** In some embodiments, the PMIC 825 may control, or otherwise be part of, various power saving mechanisms of the platform 800. For example, if the platform 800 is in an RRC\_Connected state, where it is still connected to the RAN node as it expects to receive traffic shortly, then it may enter a state known as Discontinuous Reception Mode (DRX) after a period of inactivity. During this state, the platform 800 may power down for brief intervals of time and thus save power. If there is no data traffic activity for an extended period of time, then the platform 800 may transition off to an RRC\_Idle state, where it disconnects from the network and does not perform operations such as channel quality feedback, handover, etc. The platform 800 goes into a very low power state and it performs paging where again it periodically wakes up to listen to the network and then powers down again. The platform 800 may not receive data in this state; in order to receive data, it must transition back to RRC\_Connected state. An additional power saving mode may allow a device to be unavailable to the network for periods longer than a paging interval (ranging from seconds to a few hours). During this time, the device is totally unreachable to the network and may power down completely. Any data sent during this time incurs a large delay and it is assumed the delay is acceptable.

- [0126] A battery 830 may power the platform 800, although in some examples the platform 800 may be mounted deployed in a fixed location, and may have a power supply coupled to an electrical grid. The battery 830 may be a lithium ion battery, a metal-air battery, such as a zinc-air battery, an aluminum-air battery, a lithium-air battery, and the like. In some embodiments, such as in V2X applications, the battery 830 may be a typical lead-acid automotive battery.
- [0127] In some embodiments, the battery 830 can be a “smart battery,” which includes or is coupled with a Battery Management System (BMS) or battery monitoring integrated circuitry. The BMS may be included in the platform 800 to track the state of charge (SoCh) of the battery 830. The BMS may be used to monitor other parameters of the battery 830 to provide failure predictions, such as the state of health (SoH) and the state of function (SoF) of the battery 830. The BMS communicate the information of the battery 830 to the application circuitry 805 or other components of the platform 800. The BMS may also include an analog-to-digital (ADC) convertor that allows the application circuitry 805 to directly monitor the voltage of the battery 830 or the current flow from the battery 830. The battery parameters may be used to determine actions that the platform 800 may perform, such as transmission frequency, network operation, sensing frequency, and the like.
- [0128] A power block, or other power supply coupled to an electrical grid can be coupled with the BMS to charge the battery 830. In some examples, the power block XS30 may be replaced with a wireless power receiver to obtain the power wirelessly, for example, through a loop antenna in the computer platform 800. In these examples, a wireless battery charging circuit may be included in the BMS. The specific charging circuits chosen may depend on the size of the battery 830, and thus, the current required. The charging may be performed using the Airfuel standard promulgated by the Airfuel Alliance, the Qi wireless charging standard promulgated by the Wireless Power Consortium, or the Rezence charging standard promulgated by the Alliance for Wireless Power, among others.
- [0129] User interface circuitry 850 includes various input/output (I/O) devices present within, or connected to, the platform 800, and includes one or more user interfaces designed to enable user interaction with the platform 800 and/or peripheral component interfaces designed to enable peripheral component interaction with the

platform 800. The user interface circuitry 850 includes input device circuitry and output device circuitry. Input device circuitry includes any physical or virtual means for accepting an input including, inter alia, one or more physical or virtual buttons (e.g., a reset button), a physical keyboard, keypad, mouse, touchpad, touchscreen, microphones, scanner, headset, and/or the like. The output device circuitry includes any physical or virtual means for showing information or otherwise conveying information, such as sensor readings, actuator position(s), or other like information. Output device circuitry can include any number and/or combinations of audio or visual display, including, inter alia, one or more simple visual outputs/indicators (e.g., binary status indicators (e.g., light emitting diodes (LEDs)) and multi-character visual outputs, or more complex outputs such as display devices or touchscreens (e.g., Liquid Chrystal Displays (LCD), LED displays, quantum dot displays, projectors, etc.), with the output of characters, graphics, multimedia objects, and the like being generated or produced from the operation of the platform 800. The output device circuitry may also include speakers or other audio emitting devices, printer(s), and/or the like. In some embodiments, the sensor circuitry 821 may be used as the input device circuitry (e.g., an image capture device, motion capture device, or the like) and one or more EMCs may be used as the output device circuitry (e.g., an actuator to provide haptic feedback or the like). In another example, NFC circuitry comprising an NFC controller coupled with an antenna element and a processing device may be included to read electronic tags and/or connect with another NFC-enabled device. Peripheral component interfaces can include, but are not limited to, a non-volatile memory port, a USB port, an audio jack, a power supply interface, etc.

**[0130]** Although not shown, the components of platform 800 communicate with one another using a suitable bus or interconnect (IX) technology, which can include any number of technologies, including ISA, EISA, PCI, PCIx, PCIe, a Time-Trigger Protocol (TTP) system, a FlexRay system, or any number of other technologies. The bus/IX may be a proprietary bus/IX, for example, used in a SoC based system. Other bus/IX systems may be included, such as an I<sup>2</sup>C interface, an SPI interface, point-to-point interfaces, and a power bus, among others.

#### Exemplary Baseband Circuitry and Radio Front End Modules

**[0131]** FIG. 9 illustrates example components of baseband circuitry 910 and radio front end modules (RFEM) 915 in accordance with various embodiments. The baseband

circuitry 910 corresponds to the baseband circuitry 710 and 810 of FIG. 7 and FIG. 8, respectively. The RFEM 915 corresponds to the RFEM 715 and 815 of FIG. 7 and FIG. 8, respectively. As shown, the RFEMs 915 can include Radio Frequency (RF) circuitry 906, front-end module (FEM) circuitry 908, antenna array 911 coupled together at least as shown.

**[0132]** The baseband circuitry 910 includes circuitry and/or control logic configured to carry out various radio/network protocol and radio control functions that enable communication with one or more radio networks via the RF circuitry 906. The radio control functions can include, but are not limited to, signal modulation/demodulation, encoding/decoding, radio frequency shifting, etc. In some embodiments, modulation/demodulation circuitry of the baseband circuitry 910 can include Fast-Fourier Transform (FFT), precoding, or constellation mapping/demapping functionality. In some embodiments, encoding/decoding circuitry of the baseband circuitry 910 can include convolution, tail-biting convolution, turbo, Viterbi, or Low Density Parity Check (LDPC) encoder/decoder functionality. Embodiments of modulation/demodulation and encoder/decoder functionality are not limited to these examples and can include other suitable functionality in other embodiments. The baseband circuitry 910 is configured to process baseband signals received from a receive signal path of the RF circuitry 906 and to generate baseband signals for a transmit signal path of the RF circuitry 906. The baseband circuitry 910 is configured to interface with application circuitry 705/805 (see, FIG. 7 and FIG. 8) for generation and processing of the baseband signals and for controlling operations of the RF circuitry 906. The baseband circuitry 910 handles various radio control functions.

**[0133]** The aforementioned circuitry and/or control logic of the baseband circuitry 910 can include one or more single or multi-core processors. For example, the one or more processors can include a 3G baseband processor 904A, a 4G/LTE baseband processor 904B, a 5G/NR baseband processor 904C, or some other baseband processor(s) 904D for other existing generations, generations in development or to be developed in the future (e.g., sixth generation (6G), etc.). In other embodiments, some or all of the functionality of baseband processors 904A-D may be included in modules stored in the memory 904G and executed via a Central Processing Unit (CPU) 904E. In other embodiments, some or all of the functionality of baseband processors 904A-D may be provided as hardware

accelerators (e.g., FPGAs, ASICs, etc.) loaded with the appropriate bit streams or logic blocks stored in respective memory cells. In various embodiments, the memory 904G stores program code of a real-time OS (RTOS), which when executed by the CPU 904E (or other baseband processor), is to cause the CPU 904E (or other baseband processor) to manage resources of the baseband circuitry 910, schedule tasks, etc. Examples of the RTOS can include Operating System Embedded (OSE)<sup>™</sup> provided by Enea®, Nucleus RTOS<sup>™</sup> provided by Mentor Graphics®, Versatile Real-Time Executive (VRTX) provided by Mentor Graphics®, ThreadX<sup>™</sup> provided by Express Logic®, FreeRTOS, REX OS provided by Qualcomm®, OKL4 provided by Open Kernel (OK) Labs®, or any other suitable RTOS, such as those discussed herein. In addition, the baseband circuitry 910 includes one or more audio digital signal processor(s) (DSP) 904F. The audio DSP(s) 904F include elements for compression/decompression and echo cancellation and can include other suitable processing elements in other embodiments.

**[0134]** In some embodiments, each of the processors 904A-904E include respective memory interfaces to send/receive data to/from the memory 904G. The baseband circuitry 910 may further include one or more interfaces to communicatively couple to other circuitries/devices, such as an interface to send/receive data to/from memory external to the baseband circuitry 910; an application circuitry interface to send/receive data to/from the application circuitry 705/805 of FIGS. 10-XT); an RF circuitry interface to send/receive data to/from RF circuitry 906 of FIG. 9; a wireless hardware connectivity interface to send/receive data to/from one or more wireless hardware elements (e.g., Near Field Communication (NFC) components, Bluetooth®/ Bluetooth® Low Energy components, Wi-Fi® components, and/or the like); and a power management interface to send/receive power or control signals to/from the PMIC 825.

**[0135]** In alternate embodiments (which may be combined with the above described embodiments), baseband circuitry 910 comprises one or more digital baseband systems, which are coupled with one another via an interconnect subsystem and to a CPU subsystem, an audio subsystem, and an interface subsystem. The digital baseband subsystems may also be coupled to a digital baseband interface and a mixed-signal baseband subsystem via another interconnect subsystem. Each of the interconnect subsystems can include a bus system, point-to-point connections, network-on-chip (NOC) structures, and/or some other suitable bus or interconnect technology, such as those

discussed herein. The audio subsystem can include DSP circuitry, buffer memory, program memory, speech processing accelerator circuitry, data converter circuitry such as analog-to-digital and digital-to-analog converter circuitry, analog circuitry including one or more of amplifiers and filters, and/or other like components. In an aspect of the present disclosure, baseband circuitry 910 can include protocol processing circuitry with one or more instances of control circuitry (not shown) to provide control functions for the digital baseband circuitry and/or radio frequency circuitry (e.g., the radio front end modules 915).

**[0136]** Although not illustrated in FIG. 9, in some embodiments, the baseband circuitry 910 includes individual processing device(s) to operate one or more wireless communication protocols (e.g., a “multi-protocol baseband processor” or “protocol processing circuitry”) and individual processing device(s) to implement PHY layer functions. In these embodiments, the PHY layer functions include the aforementioned radio control functions. In these embodiments, the protocol processing circuitry operates or implements various protocol layers/entities of one or more wireless communication protocols. In a first example, the protocol processing circuitry may operate LTE protocol entities and/or 5G/NR protocol entities when the baseband circuitry 910 and/or RF circuitry 906 are part of mmWave communication circuitry or some other suitable cellular communication circuitry. In the first example, the protocol processing circuitry would operate MAC, RLC, PDCP, SDAP, RRC, and NAS functions. In a second example, the protocol processing circuitry may operate one or more IEEE-based protocols when the baseband circuitry 910 and/or RF circuitry 906 are part of a Wi-Fi communication system. In the second example, the protocol processing circuitry would operate Wi-Fi MAC and logical link control (LLC) functions. The protocol processing circuitry can include one or more memory structures (e.g., 904G) to store program code and data for operating the protocol functions, as well as one or more processing cores to execute the program code and perform various operations using the data. The baseband circuitry 910 may also support radio communications for more than one wireless protocol.

**[0137]** The various hardware elements of the baseband circuitry 910 discussed herein can be implemented, for example, as a solder-down substrate including one or more integrated circuits (ICs), a single packaged IC soldered to a main circuit board or a multi-chip module containing two or more ICs. In one example, the components of the

- 44 -

baseband circuitry 910 may be suitably combined in a single chip or chipset, or disposed on a same circuit board. In another example, some or all of the constituent components of the baseband circuitry 910 and RF circuitry 906 can be implemented together such as, for example, a system on a chip (SoC) or System-in-Package (SiP). In another example, some or all of the constituent components of the baseband circuitry 910 can be implemented as a separate SoC that is communicatively coupled with and RF circuitry 906 (or multiple instances of RF circuitry 906). In yet another example, some or all of the constituent components of the baseband circuitry 910 and the application circuitry 705/805 can be implemented together as individual SoCs mounted to a same circuit board (e.g., a “multi-chip package”).

**[0138]** In some embodiments, the baseband circuitry 910 provides for communication compatible with one or more radio technologies. For example, in some embodiments, the baseband circuitry 910 supports communication with an E-UTRAN or other WMAN, a WLAN, a WPAN. Embodiments in which the baseband circuitry 910 is configured to support radio communications of more than one wireless protocol may be referred to as multi-mode baseband circuitry.

**[0139]** RF circuitry 906 may enable communication with wireless networks using modulated electromagnetic radiation through a non-solid medium. In various embodiments, the RF circuitry 906 can include switches, filters, amplifiers, etc. to facilitate the communication with the wireless network. RF circuitry 906 can include a receive signal path, which can include circuitry to down-convert RF signals received from the FEM circuitry 908 and provide baseband signals to the baseband circuitry 910. RF circuitry 906 may also include a transmit signal path, which can include circuitry to up-convert baseband signals provided by the baseband circuitry 910 and provide RF output signals to the FEM circuitry 908 for transmission.

**[0140]** In some embodiments, the receive signal path of the RF circuitry 906 can include mixer circuitry 906A, amplifier circuitry 906B and filter circuitry 906C. In some embodiments, the transmit signal path of the RF circuitry 906 can include filter circuitry 906C and mixer circuitry 906A. RF circuitry 906 may also include synthesizer circuitry 906D for synthesizing a frequency for use by the mixer circuitry 906A of the receive signal path and the transmit signal path. In some embodiments, the mixer circuitry 906A of the receive signal path can be configured to down-convert RF signals received from the

FEM circuitry 908 based on the synthesized frequency provided by synthesizer circuitry 906D. The amplifier circuitry 906B can be configured to amplify the down-converted signals and the filter circuitry 906C may be a low-pass filter (LPF) or band-pass filter (BPF) configured to remove unwanted signals from the down-converted signals to generate output baseband signals. Output baseband signals may be provided to the baseband circuitry 910 for further processing. In some embodiments, the output baseband signals may be zero-frequency baseband signals, although this is not a requirement. In some embodiments, mixer circuitry 906A of the receive signal path may comprise passive mixers, although the scope of the embodiments is not limited in this respect.

**[0141]** In some embodiments, the mixer circuitry 906A of the transmit signal path can be configured to up-convert input baseband signals based on the synthesized frequency provided by the synthesizer circuitry 906D to generate RF output signals for the FEM circuitry 908. The baseband signals may be provided by the baseband circuitry 910 and may be filtered by filter circuitry 906C.

**[0142]** In some embodiments, the mixer circuitry 906A of the receive signal path and the mixer circuitry 906A of the transmit signal path can include two or more mixers and may be arranged for quadrature downconversion and upconversion, respectively. In some embodiments, the mixer circuitry 906A of the receive signal path and the mixer circuitry 906A of the transmit signal path can include two or more mixers and may be arranged for image rejection (e.g., Hartley image rejection). In some embodiments, the mixer circuitry 906A of the receive signal path and the mixer circuitry 906A of the transmit signal path may be arranged for direct downconversion and direct upconversion, respectively. In some embodiments, the mixer circuitry 906A of the receive signal path and the mixer circuitry 906A of the transmit signal path can be configured for super-heterodyne operation.

**[0143]** In some embodiments, the output baseband signals and the input baseband signals may be analog baseband signals, although the scope of the embodiments is not limited in this respect. In some alternate embodiments, the output baseband signals and the input baseband signals may be digital baseband signals. In these alternate embodiments, the RF circuitry 906 can include analog-to-digital converter (ADC) and digital-to-analog converter (DAC) circuitry and the baseband circuitry 910 can include a digital baseband interface to communicate with the RF circuitry 906.

- [0144] In some dual-mode embodiments, a separate radio IC circuitry may be provided for processing signals for each spectrum, although the scope of the embodiments is not limited in this respect.
- [0145] In some embodiments, the synthesizer circuitry 906D may be a fractional-N synthesizer or a fractional  $N/N+1$  synthesizer, although the scope of the embodiments is not limited in this respect as other types of frequency synthesizers may be suitable. For example, synthesizer circuitry 906D may be a delta-sigma synthesizer, a frequency multiplier, or a synthesizer comprising a phase-locked loop with a frequency divider.
- [0146] The synthesizer circuitry 906D can be configured to synthesize an output frequency for use by the mixer circuitry 906A of the RF circuitry 906 based on a frequency input and a divider control input. In some embodiments, the synthesizer circuitry 906D may be a fractional  $N/N+1$  synthesizer.
- [0147] In some embodiments, frequency input may be provided by a voltage controlled oscillator (VCO), although that is not a requirement. Divider control input may be provided by either the baseband circuitry 910 or the application circuitry 705/805 depending on the desired output frequency. In some embodiments, a divider control input (e.g., N) may be determined from a look-up table based on a channel indicated by the application circuitry 705/805.
- [0148] Synthesizer circuitry 906D of the RF circuitry 906 can include a divider, a delay-locked loop (DLL), a multiplexer and a phase accumulator. In some embodiments, the divider may be a dual modulus divider (DMD) and the phase accumulator may be a digital phase accumulator (DPA). In some embodiments, the DMD can be configured to divide the input signal by either N or N+1 (e.g., based on a carry out) to provide a fractional division ratio. In some example embodiments, the DLL can include a set of cascaded, tunable, delay elements, a phase detector, a charge pump and a D-type flip-flop. In these embodiments, the delay elements can be configured to break a VCO period up into  $N_d$  equal packets of phase, where  $N_d$  is the number of delay elements in the delay line. In this way, the DLL provides negative feedback to help ensure that the total delay through the delay line is one VCO cycle.
- [0149] In some embodiments, synthesizer circuitry 906D can be configured to generate a carrier frequency as the output frequency, while in other embodiments, the output frequency may be a multiple of the carrier frequency (e.g., twice the carrier frequency,

four times the carrier frequency) and used in conjunction with quadrature generator and divider circuitry to generate multiple signals at the carrier frequency with multiple different phases with respect to each other. In some embodiments, the output frequency may be a LO frequency (fLO). In some embodiments, the RF circuitry 906 can include an IQ/polar converter.

- [0150]** FEM circuitry 908 can include a receive signal path, which can include circuitry configured to operate on RF signals received from antenna array 911, amplify the received signals and provide the amplified versions of the received signals to the RF circuitry 906 for further processing. FEM circuitry 908 may also include a transmit signal path, which can include circuitry configured to amplify signals for transmission provided by the RF circuitry 906 for transmission by one or more of antenna elements of antenna array 911. In various embodiments, the amplification through the transmit or receive signal paths may be done solely in the RF circuitry 906, solely in the FEM circuitry 908, or in both the RF circuitry 906 and the FEM circuitry 908.
- [0151]** In some embodiments, the FEM circuitry 908 can include a TX/RX switch to switch between transmit mode and receive mode operation. The FEM circuitry 908 can include a receive signal path and a transmit signal path. The receive signal path of the FEM circuitry 908 can include an LNA to amplify received RF signals and provide the amplified received RF signals as an output (e.g., to the RF circuitry 906). The transmit signal path of the FEM circuitry 908 can include a power amplifier (PA) to amplify input RF signals (e.g., provided by RF circuitry 906), and one or more filters to generate RF signals for subsequent transmission by one or more antenna elements of the antenna array 911.
- [0152]** The antenna array 911 comprises one or more antenna elements, each of which is configured convert electrical signals into radio waves to travel through the air and to convert received radio waves into electrical signals. For example, digital baseband signals provided by the baseband circuitry 910 is converted into analog RF signals (e.g., modulated waveform) that will be amplified and transmitted via the antenna elements of the antenna array 911 including one or more antenna elements (not shown). The antenna elements may be omnidirectional, direction, or a combination thereof. The antenna elements may be formed in a multitude of arrangements as are known and/or discussed herein. The antenna array 911 may comprise microstrip antennas or printed antennas that are

fabricated on the surface of one or more printed circuit boards. The antenna array 911 may be formed in as a patch of metal foil (e.g., a patch antenna) in a variety of shapes, and may be coupled with the RF circuitry 906 and/or FEM circuitry 908 using metal transmission lines or the like.

#### Exemplary Protocol Functions that Can Be Implemented In a Wireless Communication Device

- [0153]** Processors of the application circuitry 705/805 and processors of the baseband circuitry 910 may be used to execute elements of one or more instances of a protocol stack. For example, processors of the baseband circuitry 910, alone or in combination, may be used execute Layer 3, Layer 2, or Layer 1 functionality, while processors of the application circuitry 705/805 may utilize data (e.g., packet data) received from these layers and further execute Layer 4 functionality (e.g., Transmission Communication Protocol (TCP) and User Datagram Protocol (UDP) layers). As referred to herein, Layer 3 may comprise a Radio Resource Control (RRC) layer, described in further detail below. As referred to herein, Layer 2 may comprise a Medium Access Control (MAC) layer, an Radio Link Control, (RLC) layer, and a Packet Data Convergence Protocol (PDCP) layer, described in further detail below. As referred to herein, Layer 1 may comprise a Physical (PHY) layer of a UE/RAN node, described in further detail below.
- [0154]** FIG. 10 illustrates various protocol functions that can be implemented in a wireless communication device in accordance with various embodiments. In particular, FIG. 10 includes an arrangement 1000 showing interconnections between various protocol layers/entities. The following description of FIG. 10 is provided for various protocol layers/entities that operate in conjunction with the 5G/NR system standards and LTE system standards, but some or all of the aspects of FIG. 10 may be applicable to other wireless communication network systems as well.
- [0155]** The protocol layers of arrangement 1000 can include one or more of PHY 1010, MAC 1020, RLC 1030, PDCP 1040, SDAP 1047, RRC 1055, and NAS layer 1057, in addition to other higher layer functions not illustrated. The protocol layers can include one or more service access points (e.g., items 1059, 1056, 1050, 1049, 1045, 1035, 1025, and 1015 in FIG. 10) that provides communication between two or more protocol layers.
- [0156]** The PHY 1010 transmits and receives physical layer signals 1005 that may be received from or transmitted to one or more other communication devices. The physical

layer signals 1005 may comprise one or more physical channels, such as those discussed herein. The PHY 1010 may further perform link adaptation or adaptive modulation and coding (AMC), power control, cell search (e.g., for initial synchronization and handover purposes), and other measurements used by higher layers, such as the RRC 1055. The PHY 1010 may still further perform error detection on the transport channels, forward error correction (FEC) coding/decoding of the transport channels, modulation/demodulation of physical channels, interleaving, rate matching, mapping onto physical channels, and MIMO antenna processing. In some embodiments, an instance of PHY 1010 may process requests from and provide indications to an instance of MAC 1020 via one or more PHY-SAP 1015. According to some embodiments, requests and indications communicated via PHY-SAP 1015 may comprise one or more transport channels.

**[0157]** Instance(s) of MAC 1020 processes requests from, and provides indications to, an instance of RLC 1030 via one or more MAC-SAPs 1025. These requests and indications communicated via the MAC-SAP 1025 may comprise one or more logical channels. The MAC 1020 may perform mapping between the logical channels and transport channels, multiplexing of MAC SDUs from one or more logical channels onto TBs to be delivered to PHY 1010 via the transport channels, de-multiplexing MAC SDUs to one or more logical channels from TBs delivered from the PHY 1010 via transport channels, multiplexing MAC SDUs onto TBs, scheduling information reporting, error correction through HARQ, and logical channel prioritization.

**[0158]** Instance(s) of RLC 1030 processes requests from and provides indications to an instance of PDCP 1040 via one or more radio link control service access points (RLC-SAP) 1035. These requests and indications communicated via RLC-SAP 1035 may comprise one or more RLC channels. The RLC 1030 may operate in a plurality of modes of operation, including: Transparent Mode (TM), Unacknowledged Mode (UM), and Acknowledged Mode (AM). The RLC 1030 may execute transfer of upper layer protocol data units (PDUs), error correction through automatic repeat request (ARQ) for AM data transfers, and concatenation, segmentation and reassembly of RLC SDUs for UM and AM data transfers. The RLC 1030 may also execute re-segmentation of RLC data PDUs for AM data transfers, reorder RLC data PDUs for UM and AM data transfers, detect

duplicate data for UM and AM data transfers, discard RLC SDUs for UM and AM data transfers, detect protocol errors for AM data transfers, and perform RLC re-establishment.

**[0159]** Instance(s) of PDCP 1040 processes requests from and provides indications to instance(s) of RRC 1055 and/or instance(s) of SDAP 1047 via one or more packet data convergence protocol service access points (PDCP-SAP) 1045. These requests and indications communicated via PDCP-SAP 1045 may comprise one or more radio bearers. The PDCP 1040 may execute header compression and decompression of IP data, maintain PDCP Sequence Numbers (SNs), perform in-sequence delivery of upper layer PDUs at re-establishment of lower layers, eliminate duplicates of lower layer SDUs at re-establishment of lower layers for radio bearers mapped on RLC AM, cipher and decipher control plane data, perform integrity protection and integrity verification of control plane data, control timer-based discard of data, and perform security operations (e.g., ciphering, deciphering, integrity protection, integrity verification, etc.).

**[0160]** Instance(s) of SDAP 1047 processes requests from and provides indications to one or more higher layer protocol entities via one or more SDAP-SAP 1049. These requests and indications communicated via SDAP-SAP 1049 may comprise one or more QoS flows. The SDAP 1047 may map QoS flows to DRBs, and vice versa, and may also mark QFIs in DL and UL packets. A single SDAP entity 1047 can be configured for an individual PDU session. In the UL direction, the NG-RAN 410 may control the mapping of QoS Flows to DRB(s) in two different ways, reflective mapping or explicit mapping. For reflective mapping, the SDAP 1047 of a UE 401 may monitor the QFIs of the DL packets for each DRB, and may apply the same mapping for packets flowing in the UL direction. For a DRB, the SDAP 1047 of the UE 401 may map the UL packets belonging to the QoS flow(s) corresponding to the QoS flow ID(s) and PDU session observed in the DL packets for that DRB. To enable reflective mapping, the NG-RAN 610 may mark DL packets over the Uu interface with a QoS flow ID. The explicit mapping may involve the RRC 1055 configuring the SDAP 1047 with an explicit QoS flow to DRB mapping rule, which may be stored and followed by the SDAP 1047. In some embodiments, the SDAP 1047 may only be used in NR implementations and may not be used in LTE implementations.

**[0161]** The RRC 1055 configures, via one or more management service access points (M-SAP), aspects of one or more protocol layers, which can include one or more instances of

PHY 1010, MAC 1020, RLC 1030, PDCP 1040 and SDAP 1047. In some embodiments, an instance of RRC 1055 may process requests from and provide indications to one or more NAS entities 1057 via one or more RRC-SAPs 1056. The main services and functions of the RRC 1055 can include broadcast of system information (e.g., included in MIBs or SIBs related to the NAS), broadcast of system information related to the access stratum (AS), paging, establishment, maintenance and release of an RRC connection between the UE 401 and RAN 410 (e.g., RRC connection paging, RRC connection establishment, RRC connection modification, and RRC connection release), establishment, configuration, maintenance and release of point to point Radio Bearers, security functions including key management, inter-RAT mobility, and measurement configuration for UE measurement reporting. The MIBs and SIBs may comprise one or more IEs, which may each comprise individual data fields or data structures.

**[0162]** The NAS 1057 forms the highest stratum of the control plane between the UE 401 and the AMF 621. The NAS 1057 supports the mobility of the UEs 401 and the session management procedures to establish and maintain IP connectivity between the UE 401 and a P-GW in LTE systems.

**[0163]** In accordance with various embodiments, one or more protocol entities of arrangement 1000 can be implemented in UEs 401, RAN nodes 411, AMF 621 in NR implementations or MME 521 in LTE implementations, UPF 602 in NR implementations or S-GW 522 and P-GW 523 in LTE implementations, or the like to be used for control plane or user plane communications protocol stack between the aforementioned devices. In such embodiments, one or more protocol entities that can be implemented in one or more of UE 401, gNB 411, AMF 621, etc. communicate with a respective peer protocol entity that can be implemented in or on another device using the services of respective lower layer protocol entities to perform such communication. In some embodiments, a gNB-CU of the gNB 411 may host the RRC 1055, SDAP 1047, and PDCP 1040 of the gNB that controls the operation of one or more gNB-DUs, and the gNB-DUs of the gNB 411 may each host the RLC 1030, MAC 1020, and PHY 1310 of the gNB 411.

**[0164]** In a first example, a control plane protocol stack may comprise, in order from highest layer to lowest layer, NAS 1357, RRC 1355, PDCP 1040, RLC 1030, MAC 1320, and PHY 1310. In this example, upper layers 1060 may be built on top of the NAS 1357,

which includes an IP layer 1061, an SCTP 1062, and an application layer signaling protocol (AP) 1063.

**[0165]** In NR implementations, the AP 1063 may be an NG application protocol layer (NGAP or NG-AP) 1063 for the NG interface 413 defined between the NG-RAN node 411 and the AMF 621, or the AP 1063 may be an Xn application protocol layer (XnAP or Xn-AP) 1063 for the Xn interface 412 that is defined between two or more RAN nodes 411.

**[0166]** The NG-AP 1063 supports the functions of the NG interface 413 and may comprise Elementary Procedures (EPs). An NG-AP EP may be a unit of interaction between the NG-RAN node 411 and the AMF 621. The NG-AP 1063 services may comprise two groups: UE-associated services (e.g., services related to a UE 401) and non-UE-associated services (e.g., services related to the whole NG interface instance between the NG-RAN node 411 and AMF 621). These services can include functions including, but not limited to: a paging function for the sending of paging requests to NG-RAN nodes 411 involved in a particular paging area; a UE context management function for allowing the AMF 621 to establish, modify, and/or release a UE context in the AMF 621 and the NG-RAN node 411; a mobility function for UEs 401 in ECM-CONNECTED mode for intra-system HOs to support mobility within NG-RAN and inter-system HOs to support mobility from/to EPS systems; a NAS Signaling Transport function for transporting or rerouting NAS messages between UE 401 and AMF 621; a NAS node selection function for determining an association between the AMF 621 and the UE 401; NG interface management function(s) for setting up the NG interface and monitoring for errors over the NG interface; a warning message transmission function for providing means to transfer warning messages via NG interface or cancel ongoing broadcast of warning messages; a Configuration Transfer function for requesting and transferring of RAN configuration information (e.g., SON information, performance measurement (PM) data, etc.) between two RAN nodes 411 via CN 420; and/or other like functions.

**[0167]** The XnAP 1063 supports the functions of the Xn interface 412 and may comprise XnAP basic mobility procedures and XnAP global procedures. The XnAP basic mobility procedures may comprise procedures used to handle UE mobility within the NG RAN 411 (or E-UTRAN 510), such as handover preparation and cancellation procedures, SN Status Transfer procedures, UE context retrieval and UE context release procedures, RAN

paging procedures, dual connectivity related procedures, and the like. The XnAP global procedures may comprise procedures that are not related to a specific UE 401, such as Xn interface setup and reset procedures, NG-RAN update procedures, cell activation procedures, and the like.

- [0168] In LTE implementations, the AP 1063 can be an S1 Application Protocol layer (S1-AP) 1063 for the S1 interface 413 defined between an E-UTRAN node 411 and an MME, or the AP 1063 may be an X2 application protocol layer (X2AP or X2-AP) 1063 for the X2 interface 412 that is defined between two or more E-UTRAN nodes 411.
- [0169] The S1 Application Protocol layer (S1-AP) 1063 supports the functions of the S1 interface, and similar to the NG-AP discussed previously, the S1-AP may comprise S1-AP EPs. An S1-AP EP may be a unit of interaction between the E-UTRAN node 411 and an MME 521 within an LTE CN 420. The S1-AP 1063 services may comprise two groups: UE-associated services and non UE-associated services. These services perform functions including, but not limited to: E-UTRAN Radio Access Bearer (E-RAB) management, UE capability indication, mobility, NAS signaling transport, RAN Information Management (RIM), and configuration transfer.
- [0170] The X2AP 1063 supports the functions of the X2 interface 412 and may comprise X2AP basic mobility procedures and X2AP global procedures. The X2AP basic mobility procedures may comprise procedures used to handle UE mobility within the E-UTRAN 420, such as handover preparation and cancellation procedures, SN Status Transfer procedures, UE context retrieval and UE context release procedures, RAN paging procedures, dual connectivity related procedures, and the like. The X2AP global procedures may comprise procedures that are not related to a specific UE 401, such as X2 interface setup and reset procedures, load indication procedures, error indication procedures, cell activation procedures, and the like.
- [0171] The SCTP layer (alternatively referred to as the SCTP/IP layer) 1062 provides guaranteed delivery of application layer messages (e.g., NGAP or XnAP messages in NR implementations, or S1-AP or X2AP messages in LTE implementations). The SCTP 1062 may ensure reliable delivery of signaling messages between the RAN node 411 and the AMF 621/MME 521 based, in part, on the IP protocol, supported by the IP 1061. The Internet Protocol layer (IP) 1061 may be used to perform packet addressing and routing functionality. In some embodiments the IP layer 1061 may use point-to-point

transmission to deliver and convey PDUs. In this regard, the RAN node 411 may comprise L2 and L1 layer communication links (e.g., wired or wireless) with the MME/AMF to exchange information.

- [0172] In a second example, a user plane protocol stack may comprise, in order from highest layer to lowest layer, SDAP 1047, PDCP 1040, RLC 1030, MAC 1320, and PHY 1310. The user plane protocol stack may be used for communication between the UE 401, the RAN node 411, and UPF 602 in NR implementations or an S-GW 522 and P-GW 523 in LTE implementations. In this example, upper layers 1051 may be built on top of the SDAP 1047, and can include a user datagram protocol (UDP) and IP security layer (UDP/IP) 1052, a General Packet Radio Service (GPRS) Tunneling Protocol for the user plane layer (GTP-U) 1053, and a User Plane PDU layer (UP PDU) 1063.
- [0173] The transport network layer 1054 (also referred to as a “transport layer”) can be built on IP transport, and the GTP-U 1053 may be used on top of the UDP/IP layer 1052 (comprising a UDP layer and IP layer) to carry user plane PDUs (UP-PDUs). The IP layer (also referred to as the “Internet layer”) may be used to perform packet addressing and routing functionality. The IP layer may assign IP addresses to user data packets in any of IPv4, IPv6, or PPP formats, for example.
- [0174] The GTP-U 1053 is be used for carrying user data within the GPRS core network and between the radio access network and the core network. The user data transported can be packets in any of IPv4, IPv6, or PPP formats, for example. The UDP/IP 1052 provides checksums for data integrity, port numbers for addressing different functions at the source and destination, and encryption and authentication on the selected data flows. The RAN node 411 and the S-GW 522 may utilize an S1-U interface to exchange user plane data via a protocol stack comprising an L1 layer (e.g., PHY 1010), an L2 layer (e.g., MAC 1020, RLC 1030, PDCP 1040, and/or SDAP 1047), the UDP/IP layer 1052, and the GTP-U 1053. The S-GW 522 and the P-GW 523 may utilize an S5/S8a interface to exchange user plane data via a protocol stack comprising an L1 layer, an L2 layer, the UDP/IP layer 1052, and the GTP-U 1053. As discussed previously, NAS protocols supports the mobility of the UE 401 and the session management procedures to establish and maintain IP connectivity between the UE 401 and the P-GW 523.
- [0175] Moreover, although not illustrated in FIG. 10, an application layer may be present above the AP 1063 and/or the transport network layer 1054. The application layer may be

a layer in which a user of the UE 401, RAN node 411, or other network element interacts with software applications being executed, for example, by application circuitry 705 or application circuitry 805, respectively. The application layer may also provide one or more interfaces for software applications to interact with communications systems of the UE 401 or RAN node 411, such as the baseband circuitry 910. In some embodiments the IP layer and/or the application layer provides the same or similar functionality as layers 5-7, or portions thereof, of the Open Systems Interconnection (OSI) model (e.g., OSI Layer 7 – the application layer, OSI Layer 6 – the presentation layer, and OSI Layer 5 – the session layer).

**[0176]** FIG. 11 illustrates components of a core network in accordance with various embodiments. The components of the CN 520 can be implemented in one physical node or separate physical nodes including components to read and execute instructions from a machine-readable or computer-readable medium (e.g., a non-transitory machine-readable storage medium). In some embodiments, the components of CN 620 can be implemented in a same or similar manner as discussed herein with regard to the components of CN 520. In some embodiments, NFV is utilized to virtualize any or all of the above-described network node functions via executable instructions stored in one or more computer-readable storage mediums (described in further detail below). A logical instantiation of the CN 520 may be referred to as a network slice 1101, and individual logical instantiations of the CN 520 provides specific network capabilities and network characteristics. A logical instantiation of a portion of the CN 520 may be referred to as a network sub-slice 1102 (e.g., the network sub-slice 1102 is shown to include the P-GW 523 and the PCRF 526).

**[0177]** As used herein, the terms “instantiate,” “instantiation,” and the like may refer to the creation of an instance, and an “instance” may refer to a concrete occurrence of an object, which may occur, for example, during execution of program code. A network instance may refer to information identifying a domain, which may be used for traffic detection and routing in case of different IP domains or overlapping IP addresses. A network slice instance may refer to a set of network functions (NFs) instances and the resources (e.g., compute, storage, and networking resources) required to deploy the network slice.

- [0178] With respect to 5G systems (*see*, for example, FIG. 6 above), a network slice always comprises a Radio Access Network (RAN) part and a core network (CN) part. The support of network slicing relies on the principle that traffic for different slices is handled by different Protocol Data Unit (PDU) sessions. The network can realize the different network slices by scheduling and also by providing different L1/L2 configurations. The UE 601 provides assistance information for network slice selection in an appropriate Radio Resource Control (RRC) message, if it has been provided by NAS. While the network can support large number of slices, the UE need not support more than 8 slices simultaneously.
- [0179] A network slice can include the CN 620 control plane and user plane Network Functions (NFs), Next Generation Radio Access Networks (NG-RANs) 610 in a serving PLMN, and a N3IWF functions in the serving PLMN. Individual network slices may have different S-NSSAI and/or may have different SSTs. NSSAI includes one or more S-NSSAIs, and each network slice is uniquely identified by an S-NSSAI. Network slices may differ for supported features and network functions optimizations, and/or multiple network slice instances may deliver the same service/features but for different groups of UEs 601 (e.g., enterprise users). For example, individual network slices may deliver different committed service(s) and/or may be dedicated to a particular customer or enterprise. In this example, each network slice may have different S-NSSAIs with the same SST but with different slice differentiators. Additionally, a single UE may be served with one or more network slice instances simultaneously via a 5G AN and associated with eight different S-NSSAIs. Moreover, an AMF 621 instance serving an individual UE 601 may belong to each of the network slice instances serving that UE.
- [0180] Network Slicing in the NG-RAN 610 involves RAN slice awareness. RAN slice awareness includes differentiated handling of traffic for different network slices, which have been pre-configured. Slice awareness in the NG-RAN 610 is introduced at the PDU session level by indicating the S-NSSAI corresponding to a PDU session in all signaling that includes PDU session resource information. How the NG-RAN 610 supports the slice enabling in terms of NG-RAN functions (e.g., the set of network functions that comprise each slice) is implementation dependent. The NG-RAN 610 selects the RAN part of the network slice using assistance information provided by the UE 601 or the 5GC 620, which unambiguously identifies one or more of the pre-configured network slices in the

PLMN. The NG-RAN 610 also supports resource management and policy enforcement between slices as per SLAs. A single NG-RAN node supports multiple slices, and the NG-RAN 610 may also apply an appropriate RRM policy for the SLA in place to each supported slice. The NG-RAN 610 may also support QoS differentiation within a slice.

**[0181]** The NG-RAN 610 may also use the UE assistance information for the selection of an AMF 621 during an initial attach, if available. The NG-RAN 610 uses the assistance information for routing the initial NAS to an AMF 621. If the NG-RAN 610 is unable to select an AMF 621 using the assistance information, or the UE 601 does not provide any such information, the NG-RAN 610 sends the NAS signaling to a default AMF 621, which may be among a pool of AMFs 621. For subsequent accesses, the UE 601 provides a temp ID, which is assigned to the UE 601 by the 5GC 620, to enable the NG-RAN 610 to route the NAS message to the appropriate AMF 621 as long as the temp ID is valid. The NG-RAN 610 is aware of, and can reach, the AMF 621 that is associated with the temp ID. Otherwise, the method for initial attach applies.

**[0182]** The NG-RAN 610 supports resource isolation between slices. NG-RAN 610 resource isolation may be achieved by means of RRM policies and protection mechanisms that should avoid that shortage of shared resources if one slice breaks the service level agreement for another slice. In some embodiments, it is possible to fully dedicate NG-RAN 610 resources to a certain slice. How NG-RAN 610 supports resource isolation is implementation dependent.

**[0183]** Some slices may be available only in part of the network. Awareness in the NG-RAN 610 of the slices supported in the cells of its neighbors may be beneficial for inter-frequency mobility in connected mode. The slice availability may not change within the UE's registration area. The NG-RAN 610 and the 5GC 620 are responsible to handle a service request for a slice that may or may not be available in a given area. Admission or rejection of access to a slice may depend on factors such as support for the slice, availability of resources, support of the requested service by NG-RAN 610.

**[0184]** The UE 601 may be associated with multiple network slices simultaneously. In case the UE 601 is associated with multiple slices simultaneously, only one signaling connection is maintained, and for intra-frequency cell reselection, the UE 601 tries to camp on the best cell. For inter-frequency cell reselection, dedicated priorities can be used to control the frequency on which the UE 601 camps. The 5GC 620 is to validate

that the UE 601 has the rights to access a network slice. Prior to receiving an Initial Context Setup Request message, the NG-RAN 610 may be allowed to apply some provisional/local policies, based on awareness of a particular slice that the UE 601 is requesting to access. During the initial context setup, the NG-RAN 610 is informed of the slice for which resources are being requested.

**[0185]** Network Functions Virtualization (NFV) architectures and infrastructures may be used to virtualize one or more NFs, alternatively performed by proprietary hardware, onto physical resources comprising a combination of industry-standard server hardware, storage hardware, or switches. In other words, NFV systems can be used to execute virtual or reconfigurable implementations of one or more EPC components/functions.

**[0186]** FIG. 12 is a block diagram illustrating components, according to some embodiments, of a system 1400 to support Network Functions Virtualization (NFV). The system 1400 is illustrated as including a Virtualized Infrastructure Manager (VIM) 1202, a Network Functions Virtualization Infrastructure (NFVI) 1204, a Virtualized Network Function Manager (VNFM) 1206, VNFs 1208, an Element Manager (EM) 1410, a Network Functions Virtualization Orchestrator (NFVO) 1212, and a Network Manager (NM) 1214.

**[0187]** The VIM 1202 manages the resources of the NFVI 1204. The NFVI 1204 can include physical or virtual resources and applications (including hypervisors) used to execute the system 1200. The VIM 1202 may manage the life cycle of virtual resources with the NFVI 1204 (e.g., creation, maintenance, and tear down of Virtual Machines (VMs) associated with one or more physical resources), track VM instances, track performance, fault and security of VM instances and associated physical resources, and expose VM instances and associated physical resources to other management systems.

**[0188]** The VNFM 1206 may manage the VNFs 1008. The VNFs 1008 may be used to execute Evolved Packet Core (EPC) components/functions. The VNFM 1206 may manage the life cycle of the VNFs 1008 and track performance, fault and security of the virtual aspects of VNFs 1008. The EM 1210 may track the performance, fault and security of the functional aspects of VNFs 1008. The tracking data from the VNFM 1206 and the EM 1210 may comprise, for example, PM data used by the VIM 1202 or the NFVI 1204. Both the VNFM 1406 and the EM 1210 can scale up/down the quantity of VNFs of the system 1200.

- [0189] The NFVO 1212 may coordinate, authorize, release and engage resources of the NFVI 1204 in order to provide the requested service (e.g., to execute an EPC function, component, or slice). The NM 1214 provides a package of end-user functions with the responsibility for the management of a network, which can include network elements with VNFs, non-virtualized network functions, or both (management of the VNFs may occur via the EM 1210).
- [0190] FIG. 13 is a block diagram illustrating components, according to some embodiments, able to read instructions from a machine-readable or computer-readable medium (e.g., a non-transitory machine-readable storage medium) and perform any one or more of the methodologies discussed herein. Specifically, FIG. 13 shows a diagrammatic representation of hardware resources 1300 including one or more processors (or processor cores) 1310, one or more memory/storage devices 1520, and one or more communication resources 1330, each of which may be communicatively coupled via a bus 1340. For embodiments where node virtualization (e.g., NFV) is utilized, a hypervisor 1302 may be executed to provide an execution environment for one or more network slices/sub-slices to utilize the hardware resources 1300.
- [0191] The processors 1310 can include, for example, a processor 1312 and a processor 1314. The processor(s) 1310 may be, for example, a central processing unit (CPU), a reduced instruction set computing (RISC) processor, a complex instruction set computing (CISC) processor, a graphics processing unit (GPU), a DSP such as a baseband processor, an ASIC, an FPGA, a radio-frequency integrated circuit (RFIC), another processor (including those discussed herein), or any suitable combination thereof.
- [0192] The memory/storage devices 1320 can include main memory, disk storage, or any suitable combination thereof. The memory/storage devices 1320 can include, but are not limited to, any type of volatile or nonvolatile memory such as dynamic random access memory (DRAM), static random access memory (SRAM), erasable programmable read-only memory (EPROM), electrically erasable programmable read-only memory (EEPROM), Flash memory, solid-state storage, etc.
- [0193] The communication resources 1330 can include interconnection or network interface components or other suitable devices to communicate with one or more peripheral devices 1304 or one or more databases 1306 via a network 1308. For example, the communication resources 1330 can include wired communication components (e.g.,

for coupling via USB), cellular communication components, NFC components, Bluetooth® (or Bluetooth® Low Energy) components, Wi-Fi® components, and other communication components.

**[0194]** Instructions 1350 may comprise software, a program, an application, an applet, an app, or other executable code for causing at least any of the processors 1310 to perform any one or more of the methodologies discussed herein. The instructions 1350 may reside, completely or partially, within at least one of the processors 1310 (e.g., within the processor's cache memory), the memory/storage devices 1320, or any suitable combination thereof. Furthermore, any portion of the instructions 1350 may be transferred to the hardware resources 1500 from any combination of the peripheral devices 1304 or the databases 1306. Accordingly, the memory of processors 1310, the memory/storage devices 1520, the peripheral devices 1304, and the databases 1306 are examples of computer-readable and machine-readable media.

#### Exemplary Method of Operation

**[0195]** FIG. 14 illustrates a flowchart for performing a Random Access Channel (RACH) procedure according to some embodiments. The disclosure is not limited to this operational description. Rather, it will be apparent to ordinary persons skilled in the relevant art(s) that other operational control flows are within the scope and spirit of the present disclosure. The following discussion describes an exemplary operational control flow 1400 for performing a Random Access Channel (RACH) procedure as described above. The flowchart 1400 can be performed by one or more of the processors, or processor circuitry described herein, including those contained in the application circuitry 705 or 805, baseband circuitry 710 or 810, and/or processors 1314.

**[0196]** At operation 1402, the operational control flow 1400 transmits a random access preamble.

**[0197]** At operation 1404, the operational control flow 1400 receives a first message including a time-frequency resource for uplink transmission and a timing advance value. In some embodiments, the first message can be a random access response (RAR) message.

**[0198]** At operation 1406, the operational control flow 1400 applies a timing advance according to the timing advance value prior to transmitting a second message. In some embodiments, the second message can be a control plane message. In some embodiments,

the control plane message can be a connection request message or a connection resume message. In some embodiments, the second message can be message 3, where message 3 is associated with the Long Term Evolution (LTE) standard as defined by 3GPP.

**[0199]** At operation 1408, the operational control flow 1400 transmits, in the time-frequency resource, a second message in a time slot of a subframe that occurs after the timing advance in response to the first message. In these embodiments, the time slot can be dependent on an altitude of a satellite.

#### Exemplary Embodiments

**[0200]** The exemplary embodiments set forth herein are illustrative and not exhaustive. These exemplary embodiments are not meant to be limiting.

**[0201]** Some embodiments can include a method of performing random access. In these embodiments, the method can include:

- transmitting or causing to transmit a random access preamble;
- receiving or causing to receive a random access response (RAR) message, the RAR message including a time-frequency resource for uplink transmission and an indication of a time slot in which the time-frequency resource can be used; and
- transmitting or causing to transmit, in the time-frequency resource indicated in the random access response message during the time slot indicated in the random access response message, a message in response to the RAR message.

**[0202]** In these embodiments, the method can further include:

- applying or causing to apply a timing advance according to a timing advance value prior to transmitting the second message, wherein the random access response message further comprises the timing advance value.

**[0203]** Some embodiments can include a method of performing random access. In these embodiments, the method can include:

- transmitting or causing to transmit a random access preamble;
- receiving or causing to receive a random access response message, the message including a time-frequency resource for uplink transmission and a timing advance value;
- applying or causing to apply a timing advance according to the timing advance value; and

transmitting or causing to transmit, in the time-frequency resource indicated in the random access response message in a time slot determined based on the timing advance value, a message in response to the random access response message.

**[0204]** Some embodiments can include a method of performing random access. In these embodiments, the method can include:

transmitting or causing to transmit a random access preamble;  
receiving or causing to receive a first message, the first message including a time-frequency resource for uplink transmission and an indication of a time slot in which the time-frequency resource can be used; and

transmitting or causing to transmit, in the time-frequency resource indicated in the first message during the time slot indicated in the first message, a second message.

**[0205]** In these embodiments, the method can further include:

applying a timing advance according to a timing advance value prior to transmitting the second message, wherein the first message further comprises the timing advance value.

**[0206]** In these embodiments, the first message can be a random access response message and the second message can be a control plane message.

**[0207]** In these embodiments, the control plane message can include a connection request message and/or a connection resume message.

**[0208]** In these embodiments, the time slot can be dependent on an altitude of a satellite.

**[0209]** Some embodiments can include a method of performing random access. In these embodiments, the method can include:

transmitting or causing to transmit a random access preamble;  
receiving or causing to receive a first message, the first message including a time-frequency resource for uplink transmission and a timing advance value;

applying or causing to apply a timing advance according to the timing advance value; and

transmitting or causing to transmit, in the time-frequency resource indicated in the first message in a time slot determined based on the timing advance value, a second message.

**[0210]** In these embodiments, the first message can be random access response message and the second message can be a control plane message.

- [0211] In these embodiments, the control plane message can include a connection request message and/or a connection resume message.
- [0212] In these embodiments, the time slot can be dependent on an altitude of a satellite.
- [0213] Some embodiments can include a method of performing random access. In these embodiments, the method can include:
- receiving or causing to receive a random access preamble;
  - transmitting or causing to transmit a first message, the first message including a time-frequency resource for uplink transmission and an indication of a time slot in which the time-frequency resource can be used; and
  - receiving or causing to receive, in the time-frequency resource indicated in the first message during the time slot indicated in the first message, a second message.
- [0214] In these embodiments, the first message can be random access response message and the second message can be a control plane message.
- [0215] In these embodiments, the control plane message can include a connection request message and/or a connection resume message.
- [0216] In these embodiments, the time slot can be dependent on an altitude of a satellite.
- [0217] Some embodiments can include a method of performing random access. In these embodiments, the method can include:
- receiving or causing to receive a random access preamble;
  - transmitting or causing to transmit a first message, the first message including a time-frequency resource for uplink transmission and an indication of a time slot in which the time-frequency resource can be used; and
  - receiving or causing to receive, in the time-frequency resource indicated in the first message during the time slot indicated in the first message, a second message.
- [0218] In these embodiments, the first message can be random access response message and the second message can be a control plane message.
- [0219] In these embodiments, the control plane message can include a connection request message and/or a connection resume message.
- [0220] In these embodiments, the time slot can be dependent on an altitude of a satellite.
- [0221] Some embodiments can include an apparatus for use in performing random access. In these embodiments, the apparatus can be configured to:
- transmit a random access preamble;

receive a first message, the first message including a time-frequency resource for uplink transmission and an indication of a time slot in which the time-frequency resource can be used; and

transmit, in the time-frequency resource indicated in the first message during the time slot indicated in the first message, a second message.

- [0222] In these embodiments, the apparatus can be further configured to:  
apply a timing advance according to a timing advance value prior to transmitting the second message, wherein the first message further comprises the timing advance value.
- [0223] In these embodiments, the first message can be a random access response message and the second message can be a control plane message.
- [0224] In these embodiments, the control plane message can include a connection request message and/or a connection resume message.
- [0225] In these embodiments, the time slot can be dependent on an altitude of a satellite.
- [0226] Some embodiments can include an apparatus for use in performing random access. In these embodiments, the apparatus can be configured to:  
transmit a random access preamble;  
receive a first message, the first message including a time-frequency resource for uplink transmission and a timing advance value;  
apply a timing advance according to the timing advance value; and  
transmit, in the time-frequency resource indicated in the first message in a time slot determined based on the timing advance value, a second message.
- [0227] In these embodiments, the first message can be a random access response message and the second message can be a control plane message.
- [0228] In these embodiments, the control plane message can include a connection request message and/or a connection resume message.
- [0229] In these embodiments, the time slot can be dependent on an altitude of a satellite.
- [0230] Some embodiments can include an apparatus for use in performing random access. In these embodiments, the apparatus can be configured to:  
receive a random access preamble;

transmit a first message, the first message including a time-frequency resource for uplink transmission and an indication of a time slot in which the time-frequency resource can be used; and

receive, in the time-frequency resource indicated in the first message during the time slot indicated in the first message, a second message.

[0231] In these embodiments, the first message can be a random access response message and the second message can be a control plane message.

[0232] In these embodiments, the control plane message can include a connection request message and/or a connection resume message.

[0233] In these embodiments, the time slot can be dependent on an altitude of a satellite.

[0234] Some embodiments can include an apparatus for use in performing random access. In these embodiments, the apparatus can be configured to:

receive a random access preamble;

transmit a first message, the first message including a time-frequency resource for uplink transmission and an indication of a time slot in which the time-frequency resource can be used; and

receive, in the time-frequency resource indicated in the first message during the time slot indicated in the first message, a second message.

[0235] In these embodiments, the first message can be a random access response message and the second message can be a control plane message.

[0236] In these embodiments, the control plane message can include a connection request message and/or a connection resume message.

[0237] In these embodiments, the time slot can be dependent on an altitude of a satellite.

[0238] Some embodiments can include an apparatus according to any of any one of the embodiments described above, wherein the apparatus or any portion thereof is implemented in or by a user equipment (UE).

[0239] Some embodiments can include a method according to any of any one of the embodiments described above, wherein the method or any portion thereof is implemented in or by a user equipment (UE).

[0240] Some embodiments can include an apparatus according to any of any one of the embodiments described above, wherein the apparatus or any portion thereof is implemented in or by a base station (BS).

- [0241] Some embodiments can include a method according to any of any one of the embodiments described above, wherein the method or any portion thereof is implemented in or by a base station (BS).
- [0242] Some embodiments can include an apparatus comprising means to perform one or more elements of a method described in or related to any of the embodiments described above, or any other method or process described herein.
- [0243] Some embodiments can include one or more non-transitory computer-readable media comprising instructions to cause an electronic device, upon execution of the instructions by one or more processors of the electronic device, to perform one or more elements of a method described in or related to any of the embodiments described above, or any other method or process described herein.
- [0244] Some embodiments can include an apparatus comprising logic, modules, or circuitry to perform one or more elements of a method described in or related to any of the embodiments described above, or any other method or process described herein.
- [0245] Some embodiments can include a method, technique, or process as described in or related to any of the embodiments described above, or portions or parts thereof.
- [0246] Some embodiments can include an apparatus comprising: one or more processors and one or more computer-readable media comprising instructions that, when executed by the one or more processors, cause the one or more processors to perform the method, techniques, or process as described in or related to any of the embodiments described above, or portions thereof.
- [0247] Some embodiments can include a signal as described in or related to any of the embodiments described above, or portions or parts thereof.
- [0248] Some embodiments can include a signal in a wireless network as shown and described herein.
- [0249] Some embodiments can include a method of communicating in a wireless network as shown and described herein.
- [0250] Some embodiments can include a system for providing wireless communication as shown and described herein.
- [0251] Some embodiments can include a device for providing wireless communication as shown and described herein.

[0252] Some embodiments can include an apparatus comprising means for performing one or more of the methods described above in connection with the embodiments described above.

[0253] Some embodiments can include an apparatus comprising circuitry configured to perform one or more of the methods described above in connection with the embodiments described above.

[0254] Any of the above-described embodiments may be combined with any other embodiments (or combination of embodiments), unless explicitly stated otherwise. The foregoing description of one or more implementations provides illustration and description, but is not intended to be exhaustive or to limit the scope of embodiments to the precise form disclosed. Modifications and variations are possible in light of the above teachings or may be acquired from practice of various embodiments.

#### Abbreviations

[0255] For the purposes of this disclosure, the following abbreviations may apply to the examples and embodiments discussed herein, but are not meant to be limiting.

[0256]	3GPP	Third Generation Partnership Project
[0257]	4G	Fourth Generation
[0258]	5G	Fifth Generation
[0259]	5GC	5G Core network
[0260]	ACK	Acknowledgement
[0261]	AF	Application Function
[0262]	AM	Acknowledged Mode
[0263]	AMBR	Aggregate Maximum Bit Rate
[0264]	AMF	Access and Mobility Management Function
[0265]	AN	Access Network
[0266]	ANR	Automatic Neighbor Relation
[0267]	AP	Application Protocol, Antenna Port, Access Point
[0268]	API	Application Programming Interface
[0269]	APN	Access Point Name
[0270]	ARP	Allocation and Retention Priority
[0271]	ARQ	Automatic Repeat Request
[0272]	AS	Access Stratum

- 68 -

[0273]	ASN.1	Abstract Syntax Notation One
[0274]	AUSF	Authentication Server Function
[0275]	AWGN	Additive White Gaussian Noise
[0276]	BCH	Broadcast Channel
[0277]	BER	Bit Error Ratio
[0278]	BFD	Beam Failure Detection
[0279]	BLER	Block Error Rate
[0280]	BPSK	Binary Phase Shift Keying
[0281]	BRAS	Broadband Remote Access Server
[0282]	BSS	Business Support System
[0283]	BS	Base Station
[0284]	BSR	Buffer Status Report
[0285]	BW	Bandwidth
[0286]	BWP	Bandwidth Part
[0287]	C-RNTI	Cell Radio Network Temporary Identity
[0288]	CA	Carrier Aggregation, Certification Authority
[0289]	CAPEX	CAPital EXpenditure
[0290]	CBRA	Contention Based Random Access
[0291]	CC	Component Carrier, Country Code, Cryptographic Checksum
[0292]	CCA	Clear Channel Assessment
[0293]	CCE	Control Channel Element
[0294]	CCCH	Common Control Channel
[0295]	CE	Coverage Enhancement
[0296]	CDM	Content Delivery Network
[0297]	CDMA	Code-Division Multiple Access
[0298]	CFRA	Contention Free Random Access
[0299]	CG	Cell Group
[0300]	CI	Cell Identity
[0301]	CID	Cell-ID (e.g., positioning method)
[0302]	CIM	Common Information Model
[0303]	CIR	Carrier to Interference Ratio
[0304]	CK	Cipher Key

[0305]	CM	Connection Management, Conditional Mandatory
[0306]	CMAS	Commercial Mobile Alert Service
[0307]	CMD	Command
[0308]	CMS	Cloud Management System
[0309]	CO	Conditional Optional
[0310]	CoMP	Coordinated Multi-Point
[0311]	CORESET	Control Resource Set
[0312]	COTS	Commercial Off-The-Shelf
[0313]	CP	Control Plane, Cyclic Prefix, Connection Point
[0314]	CPD	Connection Point Descriptor
[0315]	CPE	Customer Premise Equipment
[0316]	CPICH	Common Pilot Channel
[0317]	CQI	Channel Quality Indicator
[0318]	CPU	CSI processing unit, Central Processing Unit
[0319]	C/R	Command/Response field bit
[0320]	CRAN	Cloud Radio Access Network, Cloud RAN
[0321]	CRB	Common Resource Block
[0322]	CRC	Cyclic Redundancy Check
[0323]	CRI	Channel-State Information Resource Indicator, CSI-RS Resource Indicator
[0324]	C-RNTI	Cell RNTI
[0325]	CS	Circuit Switched
[0326]	CSAR	Cloud Service Archive
[0327]	CSI	Channel-State Information
[0328]	CSI-IM	CSI Interference Measurement
[0329]	CSI-RS	CSI Reference Signal
[0330]	CSI-RSRP	CSI reference signal received power
[0331]	CSI-RSRQ	CSI reference signal received quality
[0332]	CSI-SINR	CSI signal-to-noise and interference ratio
[0333]	CSMA	Carrier Sense Multiple Access
[0334]	CSMA/CA	CSMA with collision avoidance
[0335]	CSS	Common Search Space, Cell-specific Search Space

- 70 -

[0336]	CTS	Clear-to-Send
[0337]	CW	Codeword
[0338]	CWS	Contention Window Size
[0339]	D2D	Device-to-Device
[0340]	DC	Dual Connectivity, Direct Current
[0341]	DCI	Downlink Control Information
[0342]	DF	Deployment Flavour
[0343]	DL	Downlink
[0344]	DMTF	Distributed Management Task Force
[0345]	DPDK	Data Plane Development Kit
[0346]	DM-RS, DMRS	Demodulation Reference Signal
[0347]	DN	Data network
[0348]	DRB	Data Radio Bearer
[0349]	DRS	Discovery Reference Signal
[0350]	DRX	Discontinuous Reception
[0351]	DSL	Domain Specific Language. Digital Subscriber Line
[0352]	DSLAM	DSL Access Multiplexer
[0353]	DwPTS	Downlink Pilot Time Slot
[0354]	E-LAN	Ethernet Local Area Network
[0355]	E2E	End-to-End
[0356]	ECCA	extended clear channel assessment, extended CCA
[0357]	ECCE	Enhanced Control Channel Element, Enhanced CCE
[0358]	ED	Energy Detection
[0359]	EDGE	Enhanced Datarates for GSM Evolution (GSM Evolution)
[0360]	EGMF	Exposure Governance Management Function
[0361]	EGPRS	Enhanced GPRS
[0362]	EIR	Equipment Identity Register
[0363]	eLAA	enhanced Licensed Assisted Access, enhanced LAA
[0364]	EM	Element Manager
[0365]	eMBB	Enhanced Mobile Broadband
[0366]	EMS	Element Management System
[0367]	eNB	evolved NodeB, E-UTRAN Node B

[0368]	EN-DC	E-UTRA-NR Dual Connectivity
[0369]	EPC	Evolved Packet Core
[0370]	EPDCCH	enhanced PDCCH, enhanced Physical Downlink Control Channel
[0371]	EPRE	Energy per resource element
[0372]	EPS	Evolved Packet System
[0373]	EREG	enhanced REG, enhanced resource element groups
[0374]	ETSI	European Telecommunications Standards Institute
[0375]	ETWS	Earthquake and Tsunami Warning System
[0376]	eUICC	embedded UICC, embedded Universal Integrated Circuit Card
[0377]	E-UTRA	Evolved UTRA
[0378]	E-UTRAN	Evolved UTRAN
[0379]	EV2X	Enhanced V2X
[0380]	F1AP	F1 Application Protocol
[0381]	F1-C	F1 Control plane interface
[0382]	F1-U	F1 User plane interface
[0383]	FACCH	Fast Associated Control Channel
[0384]	FACCH/F	Fast Associated Control Channel/Full rate
[0385]	FACCH/H	Fast Associated Control Channel/Half rate
[0386]	FACH	Forward Access Channel
[0387]	FAUSCH	Fast Uplink Signalling Channel
[0388]	FB	Functional Block
[0389]	FBI	Feedback Information
[0390]	FCC	Federal Communications Commission
[0391]	FCCH	Frequency Correction Channel
[0392]	FDD	Frequency Division Duplex
[0393]	FDM	Frequency Division Multiplex
[0394]	FDMA	Frequency Division Multiple Access
[0395]	FE	Front End
[0396]	FEC	Forward Error Correction
[0397]	FFS	For Further Study
[0398]	FFT	Fast Fourier Transformation

- 72 -

[0399]	feLAA	further enhanced Licensed Assisted Access, further enhanced LAA
[0400]	FN	Frame Number
[0401]	FPGA	Field-Programmable Gate Array
[0402]	FR	Frequency Range
[0403]	G-RNTI	GERAN Radio Network Temporary Identity
[0404]	GERAN	GSM EDGE RAN, GSM EDGE Radio Access Network
[0405]	GGSN	Gateway GPRS Support Node
[0406]	GLONASS	GLObal'naya NAVigatsionnaya Sputnikovaya Sistema (Engl.: Global Navigation Satellite System)
[0407]	gNB	Next Generation NodeB
[0408]	gNB-CU	gNB-centralized unit, Next Generation NodeB centralized unit
[0409]	gNB-DU	gNB-distributed unit, Next Generation NodeB distributed unit
[0410]	GNSS	Global Navigation Satellite System
[0411]	GPRS	General Packet Radio Service
[0412]	GSM	Global System for Mobile Communications, Groupe Spécial Mobile
[0413]	GTP	GPRS Tunneling Protocol
[0414]	GTP-U	GPRS Tunnelling Protocol for User Plane
[0415]	GTS	Go To Sleep Signal (related to WUS)
[0416]	GUMMEI	Globally Unique MME Identifier
[0417]	GUTI	Globally Unique Temporary UE Identity
[0418]	HARQ	Hybrid ARQ, Hybrid Automatic Repeat Request
[0419]	HANDOVER, HO	Handover
[0420]	HFN	HyperFrame Number
[0421]	HHO	Hard Handover
[0422]	HLR	Home Location Register
[0423]	HN	Home Network
[0424]	HO	Handover
[0425]	HPLMN	Home Public Land Mobile Network
[0426]	HSDPA	High Speed Downlink Packet Access
[0427]	HSN	Hopping Sequence Number

- 73 -

[0428]	HSPA	High Speed Packet Access
[0429]	HSS	Home Subscriber Server
[0430]	HSUPA	High Speed Uplink Packet Access
[0431]	HTTP	Hyper Text Transfer Protocol
[0432]	HTTPS	Hyper Text Transfer Protocol Secure (https is http/1.1 over SSL, i.e. port 443)
[0433]	I-Block	Information Block
[0434]	ICCID	Integrated Circuit Card Identification
[0435]	ICIC	Inter-Cell Interference Coordination
[0436]	ID	Identity, identifier
[0437]	IDFT	Inverse Discrete Fourier Transform
[0438]	IE	Information element
[0439]	IBE	In-Band Emission
[0440]	IEEE	Institute of Electrical and Electronics Engineers
[0441]	IEI	Information Element Identifier
[0442]	IEIDL	Information Element Identifier Data Length
[0443]	IETF	Internet Engineering Task Force
[0444]	IF	Infrastructure
[0445]	IM	Interference Measurement, Intermodulation, IP Multimedia
[0446]	IMC	IMS Credentials
[0447]	IMEI	International Mobile Equipment Identity
[0448]	IMGI	International mobile group identity
[0449]	IMPI	IP Multimedia Private Identity
[0450]	IMPU	IP Multimedia PUBlic identity
[0451]	IMS	IP Multimedia Subsystem
[0452]	IMSI	International Mobile Subscriber Identity
[0453]	IoT	Internet of Things
[0454]	IP	Internet Protocol
[0455]	Ipssec	IP Security, Internet Protocol Security
[0456]	IP-CAN	IP-Connectivity Access Network
[0457]	IP-M	IP Multicast
[0458]	IPv4	Internet Protocol Version 4

- 74 -

[0459]	IPv6	Internet Protocol Version 6
[0460]	IR	Infrared
[0461]	IS	In Sync
[0462]	IRP	Integration Reference Point
[0463]	ISDN	Integrated Services Digital Network
[0464]	ISIM	IM Services Identity Module
[0465]	ISO	International Organisation for Standardisation
[0466]	ISP	Internet Service Provider
[0467]	IWF	Interworking-Function
[0468]	I-WLAN	Interworking WLAN
[0469]	K	Constraint length of the convolutional code, USIM Individual key
[0470]	kB	Kilobyte (1000 bytes)
[0471]	kbps	kilo-bits per second
[0472]	Kc	Ciphering key
[0473]	Ki	Individual subscriber authentication key
[0474]	KPI	Key Performance Indicator
[0475]	KQI	Key Quality Indicator
[0476]	KSI	Key Set Identifier
[0477]	ksp/s	kilo-symbols per second
[0478]	KVM	Kernel Virtual Machine
[0479]	L1	Layer 1 (physical layer)
[0480]	L1-RSRP	Layer 1 reference signal received power
[0481]	L2	Layer 2 (data link layer)
[0482]	L3	Layer 3 (network layer)
[0483]	LAA	Licensed Assisted Access
[0484]	LAN	Local Area Network
[0485]	LBT	Listen Before Talk
[0486]	LCM	LifeCycle Management
[0487]	LCR	Low Chip Rate
[0488]	LCS	Location Services
[0489]	LCID	Logical Channel ID

- 75 -

[0490]	LI	Layer Indicator
[0491]	LLC	Logical Link Control, Low Layer Compatibility
[0492]	LPLMN	Local PLMN
[0493]	LPP	LTE Positioning Protocol
[0494]	LSB	Least Significant Bit
[0495]	LTE	Long Term Evolution
[0496]	LWA	LTE-WLAN aggregation
[0497]	LWIP	LTE/WLAN Radio Level Integration with IPsec Tunnel
[0498]	LTE	Long Term Evolution
[0499]	M2M	Machine-to-Machine
[0500]	MAC	Medium Access Control (protocol layering context)
[0501]	MAC	Message authentication code (security/encryption context)
[0502]	MAC-A	MAC used for authentication and key agreement (TSG T WG3 context)
[0503]	MAC-I	MAC used for data integrity of signalling messages (TSG T WG3 context)
[0504]	MANO	Management and Orchestration
[0505]	MBMS	Multimedia Broadcast and Multicast Service
[0506]	MBSFN	Multimedia Broadcast multicast service Single Frequency Network
[0507]	MCC	Mobile Country Code
[0508]	MCG	Master Cell Group
[0509]	MCOT	Maximum Channel Occupancy Time
[0510]	MCS	Modulation and coding scheme
[0511]	MDAF	Management Data Analytics Function
[0512]	MDAS	Management Data Analytics Service
[0513]	MDT	Minimization of Drive Tests
[0514]	ME	Mobile Equipment
[0515]	MeNB	master eNB
[0516]	MER	Message Error Ratio
[0517]	MGL	Measurement Gap Length
[0518]	MGRP	Measurement Gap Repetition Period

- 76 -

[0519]	MIB	Master Information Block, Management Information Base
[0520]	MIMO	Multiple Input Multiple Output
[0521]	MLC	Mobile Location Centre
[0522]	MM	Mobility Management
[0523]	MME	Mobility Management Entity
[0524]	MN	Master Node
[0525]	MO	Measurement Object, Mobile Originated
[0526]	MPBCH	MTC Physical Broadcast CHannel
[0527]	MPDCCH	MTC Physical Downlink Control CHannel
[0528]	MPDSCH	MTC Physical Downlink Shared CHannel
[0529]	MPRACH	MTC Physical Random Access CHannel
[0530]	MPUSCH	MTC Physical Uplink Shared Channel
[0531]	MPLS	MultiProtocol Label Switching
[0532]	MS	Mobile Station
[0533]	MSB	Most Significant Bit
[0534]	MSC	Mobile Switching Centre
[0535]	MSI	Minimum System Information, MCH Scheduling Information
[0536]	MSID	Mobile Station Identifier
[0537]	MSIN	Mobile Station Identification Number
[0538]	MSISDN	Mobile Subscriber ISDN Number
[0539]	MT	Mobile Terminated, Mobile Termination
[0540]	MTC	Machine-Type Communications
[0541]	mMTC	massive MTC, massive Machine-Type Communications
[0542]	MU-MIMO	Multi User MIMO
[0543]	MWUS	MTC wake-up signal, MTC WUS
[0544]	NACK	Negative Acknowledgement
[0545]	NAI	Network Access Identifier
[0546]	NAS	Non-Access Stratum, Non-Access Stratum layer
[0547]	NCT	Network Connectivity Topology
[0548]	NEC	Network Capability Exposure
[0549]	NE-DC	NR-E-UTRA Dual Connectivity
[0550]	NEF	Network Exposure Function

- 77 -

[0551]	NF	Network Function
[0552]	NFP	Network Forwarding Path
[0553]	NFPD	Network Forwarding Path Descriptor
[0554]	NFV	Network Functions Virtualization
[0555]	NFVI	NFV Infrastructure
[0556]	NFVO	NFV Orchestrator
[0557]	NG	Next Generation, Next Gen
[0558]	NGEN-DC	NG-RAN E-UTRA-NR Dual Connectivity
[0559]	NM	Network Manager
[0560]	NMS	Network Management System
[0561]	N-PoP	Network Point of Presence
[0562]	NMIB, N-MIB	Narrowband MIB
[0563]	NPBCH	Narrowband Physical Broadcast CHannel
[0564]	NPDCCH	Narrowband Physical Downlink Control CHannel
[0565]	NPDSCH	Narrowband Physical Downlink Shared CHannel
[0566]	NPRACH	Narrowband Physical Random Access CHannel
[0567]	NPUSCH	Narrowband Physical Uplink Shared CHannel
[0568]	NPSS	Narrowband Primary Synchronization Signal
[0569]	NSSS	Narrowband Secondary Synchronization Signal
[0570]	NR	New Radio, Neighbor Relation
[0571]	NRF	NF Repository Function
[0572]	NRS	Narrowband Reference Signal
[0573]	NS	Network Service
[0574]	NSA	Non-Standalone operation mode
[0575]	NSD	Network Service Descriptor
[0576]	NSR	Network Service Record
[0577]	NSSAI	Network Slice Selection Assistance Information
[0578]	S-NNSAI	Single-NSSAI
[0579]	NSSF	Network Slice Selection Function
[0580]	NW	Network
[0581]	NWUS	Narrowband wake-up signal, Narrowband WUS
[0582]	NZP	Non-Zero Power

- 78 -

[0583]	O&M	Operation and Maintenance
[0584]	ODU2	Optical channel Data Unit - type 2
[0585]	OFDM	Orthogonal Frequency Division Multiplexing
[0586]	OFDMA	Orthogonal Frequency Division Multiple Access
[0587]	OOB	Out-of-band
[0588]	OOS	Out of Sync
[0589]	OPEX	OPerating EXpense
[0590]	OSI	Other System Information
[0591]	OSS	Operations Support System
[0592]	OTA	over-the-air
[0593]	PAPR	Peak-to-Average Power Ratio
[0594]	PAR	Peak to Average Ratio
[0595]	PBCH	Physical Broadcast Channel
[0596]	PC	Power Control, Personal Computer
[0597]	PCC	Primary Component Carrier, Primary CC
[0598]	PCell	Primary Cell
[0599]	PCI	Physical Cell ID, Physical Cell Identity
[0600]	PCEF	Policy and Charging Enforcement Function
[0601]	PCF	Policy Control Function
[0602]	PCRF	Policy Control and Charging Rules Function
[0603]	PDCP	Packet Data Convergence Protocol, Packet Data Convergence Protocol layer
[0604]	PDCCH	Physical Downlink Control Channel
[0605]	PDCP	Packet Data Convergence Protocol
[0606]	PDN	Packet Data Network, Public Data Network
[0607]	PDSCH	Physical Downlink Shared Channel
[0608]	PDU	Protocol Data Unit
[0609]	PEI	Permanent Equipment Identifiers
[0610]	PF	Packet Flow Description
[0611]	P-GW	PDN Gateway
[0612]	PHICH	Physical hybrid-ARQ indicator channel
[0613]	PHY	Physical layer

[0614]	PLMN	Public Land Mobile Network
[0615]	PIN	Personal Identification Number
[0616]	PM	Performance Measurement
[0617]	PMI	Precoding Matrix Indicator
[0618]	PNF	Physical Network Function
[0619]	PNFD	Physical Network Function Descriptor
[0620]	PNFR	Physical Network Function Record
[0621]	POC	PTT over Cellular
[0622]	PP, PTP	Point-to-Point
[0623]	PPP	Point-to-Point Protocol
[0624]	PRACH	Physical RACH
[0625]	PRB	Physical resource block
[0626]	PRG	Physical resource block group
[0627]	ProSe	Proximity Services, Proximity-Based Service
[0628]	PRS	Positioning Reference Signal
[0629]	PRR	Packet Reception Radio
[0630]	PS	Packet Services
[0631]	PSBCH	Physical Sidelink Broadcast Channel
[0632]	PSDCH	Physical Sidelink Downlink Channel
[0633]	PSCCH	Physical Sidelink Control Channel
[0634]	PSSCH	Physical Sidelink Shared Channel
[0635]	PSCell	Primary SCell
[0636]	PSS	Primary Synchronization Signal
[0637]	PSTN	Public Switched Telephone Network
[0638]	PT-RS	Phase-tracking reference signal
[0639]	PTT	Push-to-Talk
[0640]	PUCCH	Physical Uplink Control Channel
[0641]	PUSCH	Physical Uplink Shared Channel
[0642]	QAM	Quadrature Amplitude Modulation
[0643]	QCI	QoS class of identifier
[0644]	QCL	Quasi co-location
[0645]	QFI	QoS Flow ID, QoS Flow Identifier

[0646]	QoS	Quality of Service
[0647]	QPSK	Quadrature (Quaternary) Phase Shift Keying
[0648]	QZSS	Quasi-Zenith Satellite System
[0649]	RA-RNTI	Random Access RNTI
[0650]	RAB	Radio Access Bearer, Random Access Burst
[0651]	RACH	Random Access Channel
[0652]	RADIUS	Remote Authentication Dial In User Service
[0653]	RAN	Radio Access Network
[0654]	RAND	RANDom number (used for authentication)
[0655]	RAR	Random Access Response
[0656]	RAT	Radio Access Technology
[0657]	RAU	Routing Area Update
[0658]	RB	Resource block, Radio Bearer
[0659]	RBG	Resource block group
[0660]	REG	Resource Element Group
[0661]	Rel	Release
[0662]	REQ	REQuest
[0663]	RF	Radio Frequency
[0664]	RI	Rank Indicator
[0665]	RIV	Resource indicator value
[0666]	RL	Radio Link
[0667]	RLC	Radio Link Control, Radio Link Control layer
[0668]	RLC AM	RLC Acknowledged Mode
[0669]	RLC UM	RLC Unacknowledged Mode
[0670]	RLF	Radio Link Failure
[0671]	RLM	Radio Link Monitoring
[0672]	RLM-RS	Reference Signal for RLM
[0673]	RM	Registration Management
[0674]	RMC	Reference Measurement Channel
[0675]	RMSI	Remaining MSI, Remaining Minimum System Information
[0676]	RN	Relay Node
[0677]	RNC	Radio Network Controller

[0678]	RNL	Radio Network Layer
[0679]	RNTI	Radio Network Temporary Identifier
[0680]	ROHC	RObust Header Compression
[0681]	RRC	Radio Resource Control, Radio Resource Control layer
[0682]	RRM	Radio Resource Management
[0683]	RS	Reference Signal
[0684]	RSRP	Reference Signal Received Power
[0685]	RSRQ	Reference Signal Received Quality
[0686]	RSSI	Received Signal Strength Indicator
[0687]	RSU	Road Side Unit
[0688]	RSTD	Reference Signal Time difference
[0689]	RTP	Real Time Protocol
[0690]	RTS	Ready-To-Send
[0691]	RTT	Round Trip Time
[0692]	Rx	Reception, Receiving, Receiver
[0693]	S1AP	S1 Application Protocol
[0694]	S1-MME	S1 for the control plane
[0695]	S1-U	S1 for the user plane
[0696]	S-GW	Serving Gateway
[0697]	S-RNTI	SRNC Radio Network Temporary Identity
[0698]	S-TMSI	SAE Temporary Mobile Station Identifier
[0699]	SA	Standalone operation mode
[0700]	SAE	System Architecture Evolution
[0701]	SAP	Service Access Point
[0702]	SAPD	Service Access Point Descriptor
[0703]	SAPI	Service Access Point Identifier
[0704]	SCC	Secondary Component Carrier, Secondary CC
[0705]	SCell	Secondary Cell
[0706]	SC-FDMA	Single Carrier Frequency Division Multiple Access
[0707]	SCG	Secondary Cell Group
[0708]	SCM	Security Context Management
[0709]	SCS	Subcarrier Spacing

[0710]	SCTP	Stream Control Transmission Protocol
[0711]	SDAP	Service Data Adaptation Protocol, Service Data Adaptation Protocol layer
[0712]	SDL	Supplementary Downlink
[0713]	SDNF	Structured Data Storage Network Function
[0714]	SDP	Service Discovery Protocol (Bluetooth related)
[0715]	SDSF	Structured Data Storage Function
[0716]	SDU	Service Data Unit
[0717]	SEAF	Security Anchor Function
[0718]	SeNB	secondary eNB
[0719]	SEPP	Security Edge Protection Proxy
[0720]	SFI	Slot format indication
[0721]	SFTD	Space-Frequency Time Diversity, SFN and frame timing difference
[0722]	SFN	System Frame Number
[0723]	SgNB	Secondary gNB
[0724]	SGSN	Serving GPRS Support Node
[0725]	S-GW	Serving Gateway
[0726]	SI	System Information
[0727]	SI-RNTI	System Information RNTI
[0728]	SIB	System Information Block
[0729]	SIM	Subscriber Identity Module
[0730]	SIP	Session Initiated Protocol
[0731]	SiP	System in Package
[0732]	SL	Sidelink
[0733]	SLA	Service Level Agreement
[0734]	SM	Session Management
[0735]	SMF	Session Management Function
[0736]	SMS	Short Message Service
[0737]	SMSF	SMS Function
[0738]	SMTC	SSB-based Measurement Timing Configuration
[0739]	SN	Secondary Node, Sequence Number

[0740]	SoC	System on Chip
[0741]	SON	Self-Organizing Network
[0742]	SpCell	Special Cell
[0743]	SP-CSI-RNTI	Semi-Persistent CSI RNTI
[0744]	SPS	Semi-Persistent Scheduling
[0745]	SQN	Sequence number
[0746]	SR	Scheduling Request
[0747]	SRB	Signalling Radio Bearer
[0748]	SRS	Sounding Reference Signal
[0749]	SS	Synchronization Signal
[0750]	SSB	Synchronization Signal Block, SS/PBCH Block
[0751]	SSBRI	SS/PBCH Block Resource Indicator, Synchronization Signal Block Resource Indicator
[0752]	SSC	Session and Service Continuity
[0753]	SS-RSRP	Synchronization Signal based Reference Signal Received Power
[0754]	SS-RSRQ	Synchronization Signal based Reference Signal Received Quality
[0755]	SS-SINR	Synchronization Signal based Signal to Noise and Interference Ratio
[0756]	SSS	Secondary Synchronization Signal
[0757]	SSSG	Search Space Set Group
[0758]	SSSIF	Search Space Set Indicator
[0759]	SST	Slice/Service Types
[0760]	SU-MIMO	Single User MIMO
[0761]	SUL	Supplementary Uplink
[0762]	TA	Timing Advance, Tracking Area
[0763]	TAC	Tracking Area Code
[0764]	TAG	Timing Advance Group
[0765]	TAU	Tracking Area Update
[0766]	TB	Transport Block
[0767]	TBS	Transport Block Size
[0768]	TBD	To Be Defined
[0769]	TCI	Transmission Configuration Indicator

[0770]	TCP	Transmission Communication Protocol
[0771]	TDD	Time Division Duplex
[0772]	TDM	Time Division Multiplexing
[0773]	TDMA	Time Division Multiple Access
[0774]	TE	Terminal Equipment
[0775]	TEID	Tunnel End Point Identifier
[0776]	TFT	Traffic Flow Template
[0777]	TMSI	Temporary Mobile Subscriber Identity
[0778]	TNL	Transport Network Layer
[0779]	TPC	Transmit Power Control
[0780]	TPMI	Transmitted Precoding Matrix Indicator
[0781]	TR	Technical Report
[0782]	TRP, TRxP	Transmission Reception Point
[0783]	TRS	Tracking Reference Signal
[0784]	TRx	Transceiver
[0785]	TS	Technical Specifications, Technical Standard
[0786]	TTI	Transmission Time Interval
[0787]	Tx	Transmission, Transmitting, Transmitter
[0788]	U-RNTI	UTRAN Radio Network Temporary Identity
[0789]	UART	Universal Asynchronous Receiver and Transmitter
[0790]	UCI	Uplink Control Information
[0791]	UE	User Equipment
[0792]	UDM	Unified Data Management
[0793]	UDP	User Datagram Protocol
[0794]	UDSF	Unstructured Data Storage Network Function
[0795]	UICC	Universal Integrated Circuit Card
[0796]	UL	Uplink
[0797]	UM	Unacknowledged Mode
[0798]	UML	Unified Modelling Language
[0799]	UMTS	Universal Mobile Telecommunications System
[0800]	UP	User Plane
[0801]	UPF	User Plane Function

[0802]	URI	Uniform Resource Identifier
[0803]	URL	Uniform Resource Locator
[0804]	URLLC	Ultra-Reliable and Low Latency
[0805]	USB	Universal Serial Bus
[0806]	USIM	Universal Subscriber Identity Module
[0807]	USS	UE-specific search space
[0808]	UTRA	UMTS Terrestrial Radio Access
[0809]	UTRAN	Universal Terrestrial Radio Access Network
[0810]	UwPTS	Uplink Pilot Time Slot
[0811]	V2I	Vehicle-to-Infrastructure
[0812]	V2P	Vehicle-to-Pedestrian
[0813]	V2V	Vehicle-to-Vehicle
[0814]	V2X	Vehicle-to-everything
[0815]	VIM	Virtualized Infrastructure Manager
[0816]	VL	Virtual Link,
[0817]	VLAN	Virtual LAN, Virtual Local Area Network
[0818]	VM	Virtual Machine
[0819]	VNF	Virtualized Network Function
[0820]	VNFFG	VNF Forwarding Graph
[0821]	VNFFGD	VNF Forwarding Graph Descriptor
[0822]	VNFM	VNF Manager
[0823]	VoIP	Voice-over-IP, Voice-over-Internet Protocol
[0824]	VPLMN	Visited Public Land Mobile Network
[0825]	VPN	Virtual Private Network
[0826]	VRB	Virtual Resource Block
[0827]	WiMAX	Worldwide Interoperability for Microwave Access
[0828]	WLAN	Wireless Local Area Network
[0829]	WMAN	Wireless Metropolitan Area Network
[0830]	WPAN	Wireless Personal Area Network
[0831]	X2-C	X2-Control plane
[0832]	X2-U	X2-User plane
[0833]	XML	eXtensible Markup Language

[0834]	2ES	EXpected user RESponse
[0835]	XOR	eXclusive OR
[0836]	ZC	Zadoff-Chu
[0837]	ZP	Zero Power

#### Exemplary Terminology

[0838] For the purposes of the present document, the following terms and definitions are applicable to the examples and embodiments discussed herein, but are not meant to be limiting.

[0839] The term “circuitry” as used herein refers to, is part of, or includes hardware components such as an electronic circuit, a logic circuit, a processor (shared, dedicated, or group) and/or memory (shared, dedicated, or group), an Application Specific Integrated Circuit (ASIC), a field-programmable device (FPD) (e.g., a field-programmable gate array (FPGA), a programmable logic device (PLD), a complex PLD (CPLD), a high-capacity PLD (HCPLD), a structured ASIC, or a programmable SoC), digital signal processors (DSPs), etc., that are configured to provide the described functionality. In some embodiments, the circuitry may execute one or more software or firmware programs to provide at least some of the described functionality. The term “circuitry” may also refer to a combination of one or more hardware elements (or a combination of circuits used in an electrical or electronic system) with the program code used to carry out the functionality of that program code. In these embodiments, the combination of hardware elements and program code may be referred to as a particular type of circuitry.

[0840] The term “processor circuitry” as used herein refers to, is part of, or includes circuitry capable of sequentially and automatically carrying out a sequence of arithmetic or logical operations, or recording, storing, and/or transferring digital data. The term “processor circuitry” may refer to one or more application processors, one or more baseband processors, a physical central processing unit (CPU), a single-core processor, a dual-core processor, a triple-core processor, a quad-core processor, and/or any other device capable of executing or otherwise operating computer-executable instructions, such as program code, software modules, and/or functional processes. The terms “application circuitry” and/or “baseband circuitry” may be considered synonymous to, and may be referred to as, “processor circuitry.”

- [0841]** The term “interface circuitry” as used herein refers to, is part of, or includes circuitry that enables the exchange of information between two or more components or devices. The term “interface circuitry” may refer to one or more hardware interfaces, for example, buses, I/O interfaces, peripheral component interfaces, network interface cards, and/or the like.
- [0842]** The term “user equipment” or “UE” as used herein refers to a device with radio communication capabilities and may describe a remote user of network resources in a communications network. The term “user equipment” or “UE” may be considered synonymous to, and may be referred to as, client, mobile, mobile device, mobile terminal, user terminal, mobile unit, mobile station, mobile user, subscriber, user, remote station, access agent, user agent, receiver, radio equipment, reconfigurable radio equipment, reconfigurable mobile device, etc. Furthermore, the term “user equipment” or “UE” may include any type of wireless/wired device or any computing device including a wireless communications interface.
- [0843]** The term “network element” as used herein refers to physical or virtualized equipment and/or infrastructure used to provide wired or wireless communication network services. The term “network element” may be considered synonymous to and/or referred to as a networked computer, networking hardware, network equipment, network node, router, switch, hub, bridge, radio network controller, RAN device, RAN node, gateway, server, virtualized VNF, NFVI, and/or the like.
- [0844]** The term “computer system” as used herein refers to any type interconnected electronic devices, computer devices, or components thereof. Additionally, the term “computer system” and/or “system” may refer to various components of a computer that are communicatively coupled with one another. Furthermore, the term “computer system” and/or “system” may refer to multiple computer devices and/or multiple computing systems that are communicatively coupled with one another and configured to share computing and/or networking resources.
- [0845]** The term “appliance,” “computer appliance,” or the like, as used herein refers to a computer device or computer system with program code (e.g., software or firmware) that is specifically designed to provide a specific computing resource. A “virtual appliance” is a virtual machine image to be implemented by a hypervisor-equipped device that

virtualizes or emulates a computer appliance or otherwise is dedicated to provide a specific computing resource.

**[0846]** The term “resource” as used herein refers to a physical or virtual device, a physical or virtual component within a computing environment, and/or a physical or virtual component within a particular device, such as computer devices, mechanical devices, memory space, processor/CPU time, processor/CPU usage, processor and accelerator loads, hardware time or usage, electrical power, input/output operations, ports or network sockets, channel/link allocation, throughput, memory usage, storage, network, database and applications, workload units, and/or the like. A “hardware resource” may refer to compute, storage, and/or network resources provided by physical hardware element(s). A “virtualized resource” may refer to compute, storage, and/or network resources provided by virtualization infrastructure to an application, device, system, etc. The term “network resource” or “communication resource” may refer to resources that are accessible by computer devices/systems via a communications network. The term “system resources” may refer to any kind of shared entities to provide services, and may include computing and/or network resources. System resources may be considered as a set of coherent functions, network data objects or services, accessible through a server where such system resources reside on a single host or multiple hosts and are clearly identifiable.

**[0847]** The term “channel” as used herein refers to any transmission medium, either tangible or intangible, which is used to communicate data or a data stream. The term “channel” may be synonymous with and/or equivalent to “communications channel,” “data communications channel,” “transmission channel,” “data transmission channel,” “access channel,” “data access channel,” “link,” “data link,” “carrier,” “radiofrequency carrier,” and/or any other like term denoting a pathway or medium through which data is communicated. Additionally, the term “link” as used herein refers to a connection between two devices through a RAT for the purpose of transmitting and receiving information.

**[0848]** The terms “instantiate,” “instantiation,” and the like as used herein refers to the creation of an instance. An “instance” also refers to a concrete occurrence of an object, which may occur, for example, during execution of program code.

- [0849] The terms “coupled,” “communicatively coupled,” along with derivatives thereof are used herein. The term “coupled” may mean two or more elements are in direct physical or electrical contact with one another, may mean that two or more elements indirectly contact each other but still cooperate or interact with each other, and/or may mean that one or more other elements are coupled or connected between the elements that are said to be coupled with each other. The term “directly coupled” may mean that two or more elements are in direct contact with one another. The term “communicatively coupled” may mean that two or more elements may be in contact with one another by a means of communication including through a wire or other interconnect connection, through a wireless communication channel or link, and/or the like.
- [0850] The term “information element” refers to a structural element containing one or more fields. The term “field” refers to individual contents of an information element, or a data element that contains content.
- [0851] The term “SMTC” refers to an SSB-based measurement timing configuration configured by *SSB-MeasurementTimingConfiguration*.
- [0852] The term “SSB” refers to an SS/PBCH block.
- [0853] The term “a “Primary Cell” refers to the MCG cell, operating on the primary frequency, in which the UE either performs the initial connection establishment procedure or initiates the connection re-establishment procedure.
- [0854] The term “Primary SCG Cell” refers to the SCG cell in which the UE performs random access when performing the Reconfiguration with Sync procedure for DC operation.
- [0855] The term “Secondary Cell” refers to a cell providing additional radio resources on top of a Special Cell for a UE configured with CA.
- [0856] The term “Secondary Cell Group” refers to the subset of serving cells comprising the PSCell and zero or more secondary cells for a UE configured with DC.
- [0857] The term “Serving Cell” refers to the primary cell for a UE in RRC\_CONNECTED not configured with CA/DC there is only one serving cell comprising of the primary cell.
- [0858] The term “serving cell” or “serving cells” refers to the set of cells comprising the Special Cell(s) and all secondary cells for a UE in RRC\_CONNECTED configured with CA/.

[0859] The term “Special Cell” refers to the PCell of the MCG or the PSCell of the SCG for DC operation; otherwise, the term “Special Cell” refers to the Pcell.

## WHAT IS CLAIMED IS:

1. A method for performing a Random Access Channel (RACH) procedure, the method comprising:
  - receiving a first message including a time-frequency resource for uplink transmission and a timing advance value;
  - applying a timing advance according to the timing advance value prior to transmitting a second message; and
  - transmitting, in the time-frequency resource, the second message in a time slot of a subframe that occurs after the timing advance.
2. The method of claim 1, wherein the first message comprises:
  - a random access response (RAR) message, and
  - wherein the second message comprises:
    - a control plane message.
3. The method of claim 2, wherein the control plane message comprises a connection request message or a connection resume message.
4. The method of claim 1, wherein the second message comprises message 3.
5. The method of claim 1, wherein the time slot is dependent on an altitude of a satellite.
6. The method of claim 1, further comprising:
  - transmitting a third message prior to receiving the first message,
  - wherein the receiving comprises:
    - receiving the first message in response to transmitting the third message.
7. The method of claim 6, wherein the third message comprises:
  - a random access preamble.

- 92 -

8. An apparatus for performing a Random Access Channel (RACH) procedure, the method comprising:
  - radio front end circuitry configured to:
    - receive a first message including a time-frequency resource for uplink transmission and a timing advance value, and
    - transmit, in the time-frequency resource, a second message in a time slot of a subframe that occurs after the timing advance; and
  - processor circuitry configured to apply the timing advance according to the timing advance value prior to the radio front end circuitry transmitting the second message.
9. The apparatus of claim 8, wherein the first message comprises:
  - a random access response (RAR) message, and
  - wherein the second message comprises:
    - a control plane message.
10. The apparatus of claim 9, wherein the control plane message comprises a connection request message or a connection resume message.
11. The apparatus of claim 8, wherein the second message comprises message 3.
12. The apparatus of claim 8, wherein the time slot is dependent on an altitude of a satellite.
13. The apparatus of claim 8, wherein the radio front end circuitry is further configured to transmit a random access preamble prior to being configured to receive the first message.
14. A system for performing a Random Access Channel (RACH) procedure, the system comprising:
  - a Next Generation NodeB (gNB) configured to transmit a first message including a time-frequency resource for uplink transmission and a timing advance value,
  - a user equipment (UE) configured to:

- 93 -

apply a timing advance according to the timing advance value prior to transmitting a second message, and

transmit, in the time-frequency resource, the second message in a time slot of a subframe that occurs after the timing advance.

15. The system of claim 14, wherein the first message comprises:  
a random access response (RAR) message, and  
wherein the second message comprises:  
a control plane message.
16. The system of claim 15, wherein the control plane message comprises a connection request message or a connection resume message.
17. The system of claim 14, wherein the second message comprises message 3.
18. The system of claim 17, wherein message 3 is associated with a Long Term Evolution (LTE) communication standard as defined by the Third Generation Partnership Project (3GPP).
19. The system of claim 14, wherein the time slot is dependent on an altitude of a satellite.
20. The system of claim 14, wherein the UE is further configured to transmit a random access preamble prior to being configured to receive the first message.

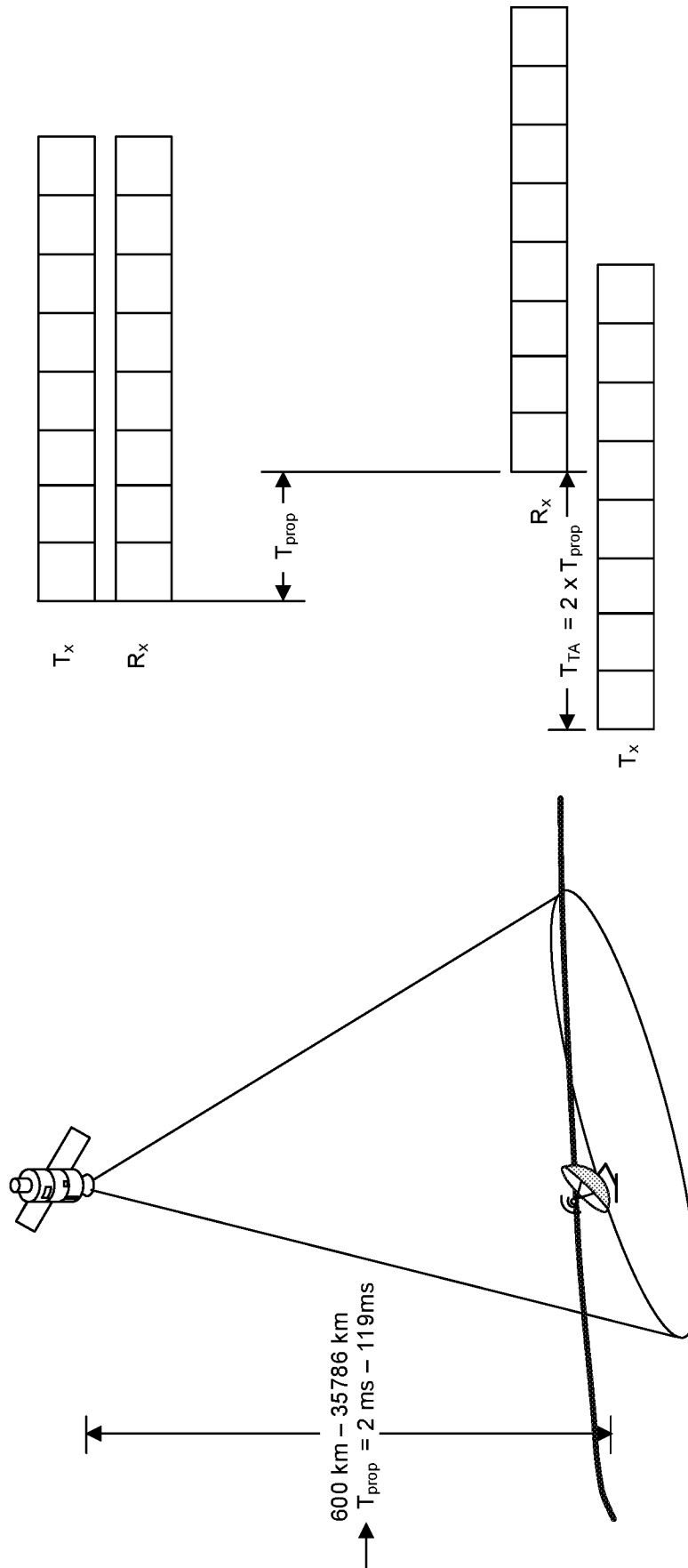

FIG. 1

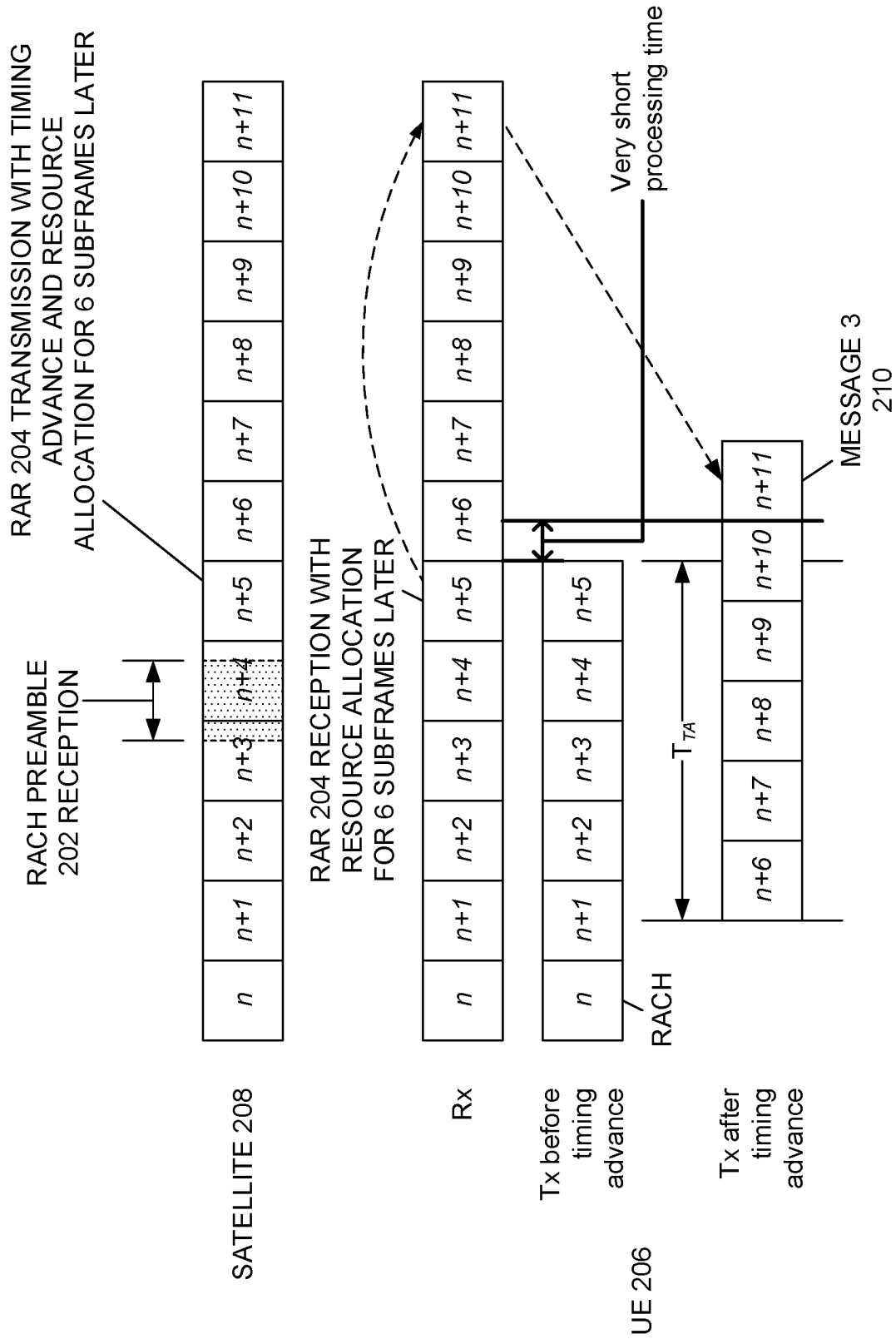

FIG. 2

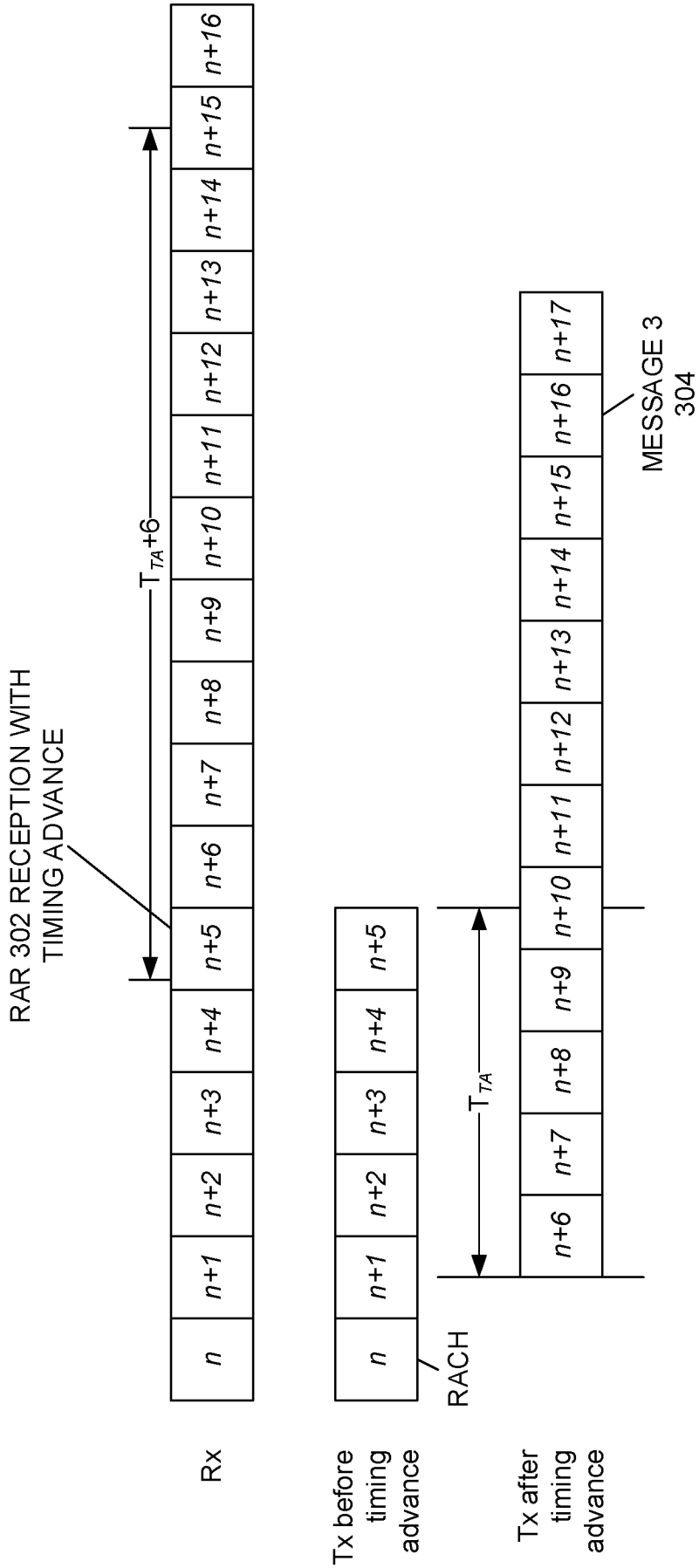

FIG. 3

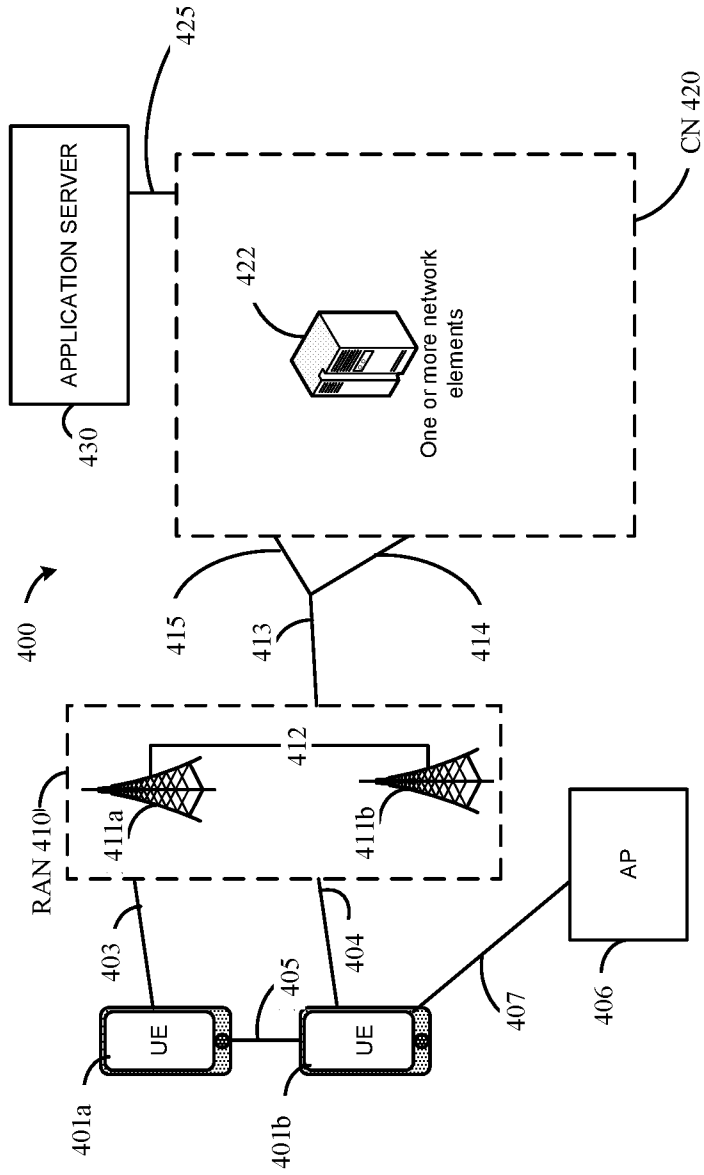

FIG. 4

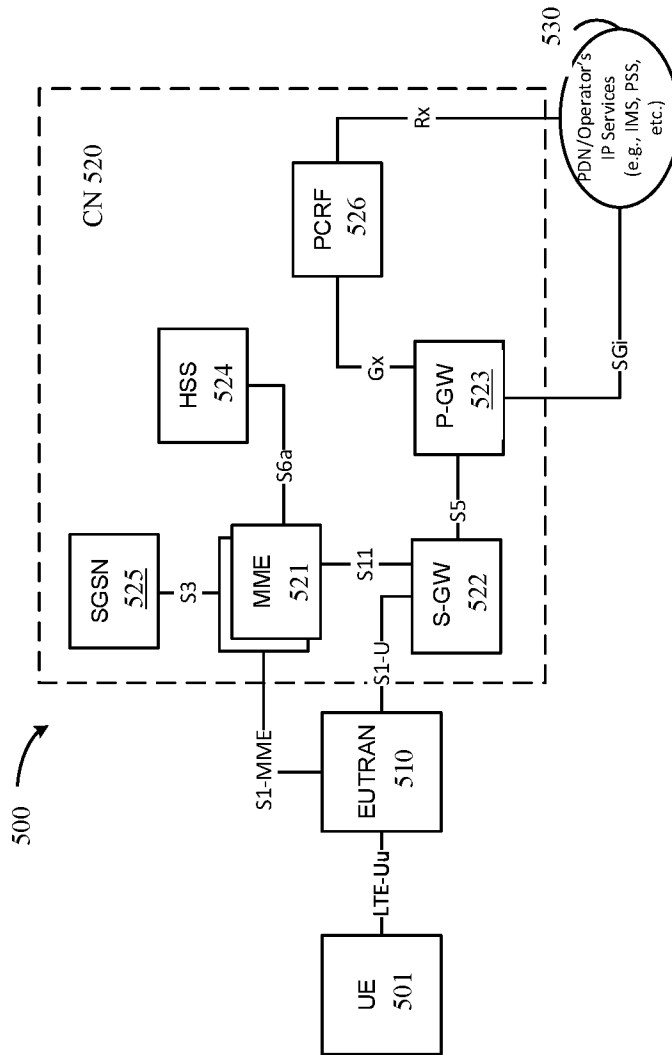

FIG. 5

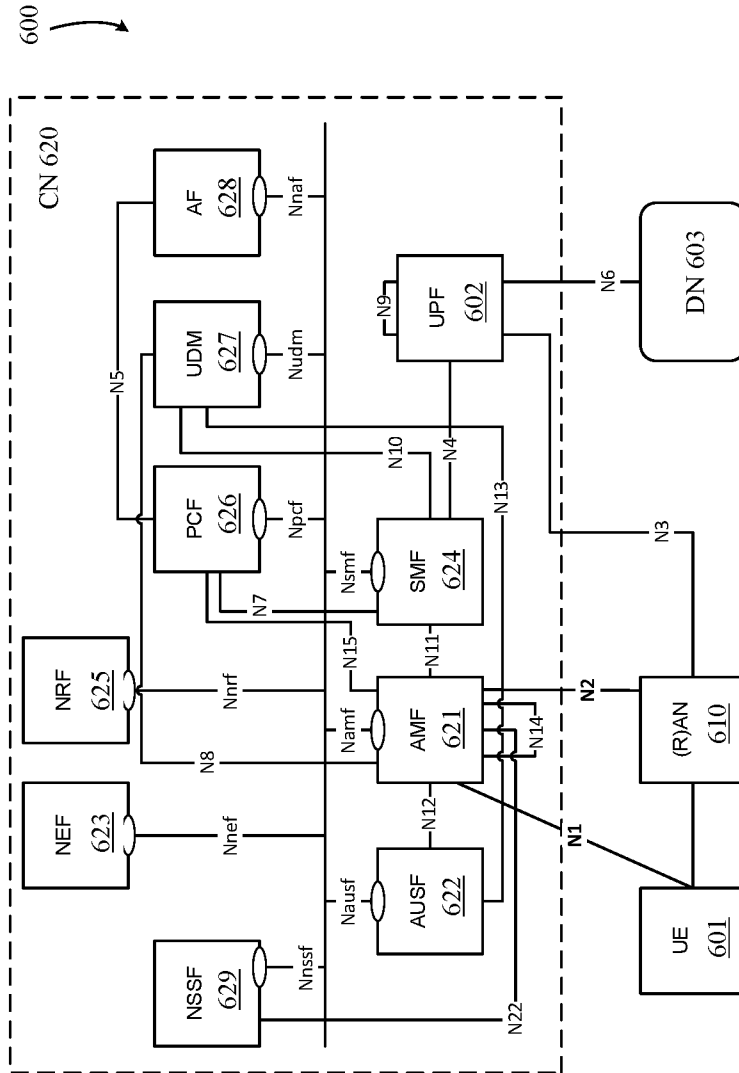

FIG. 6

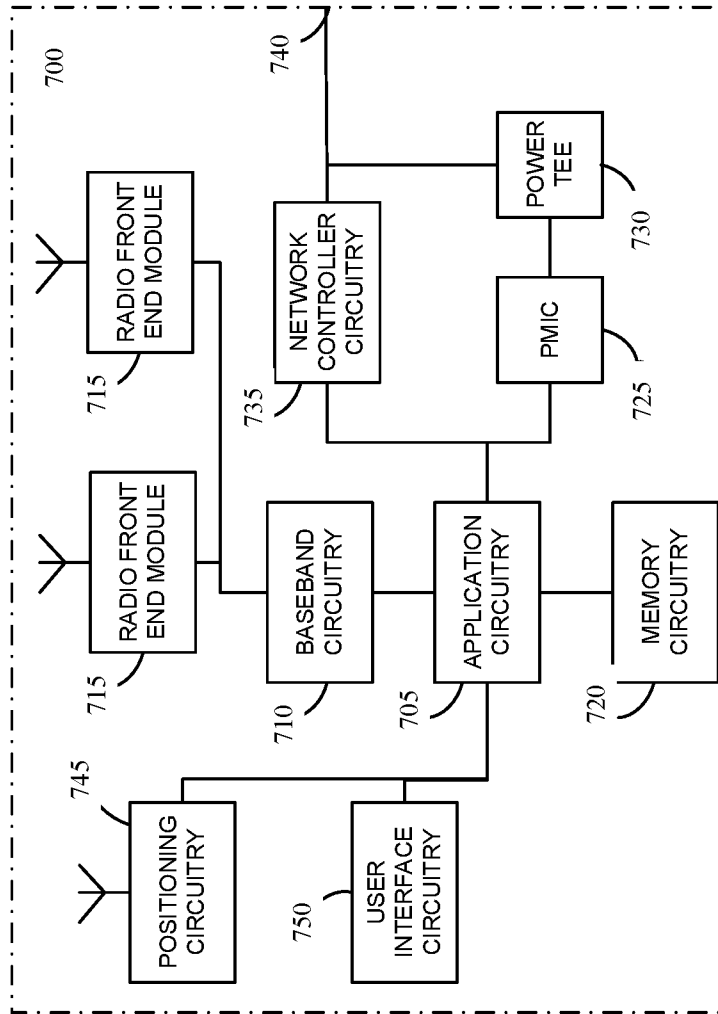

FIG. 7

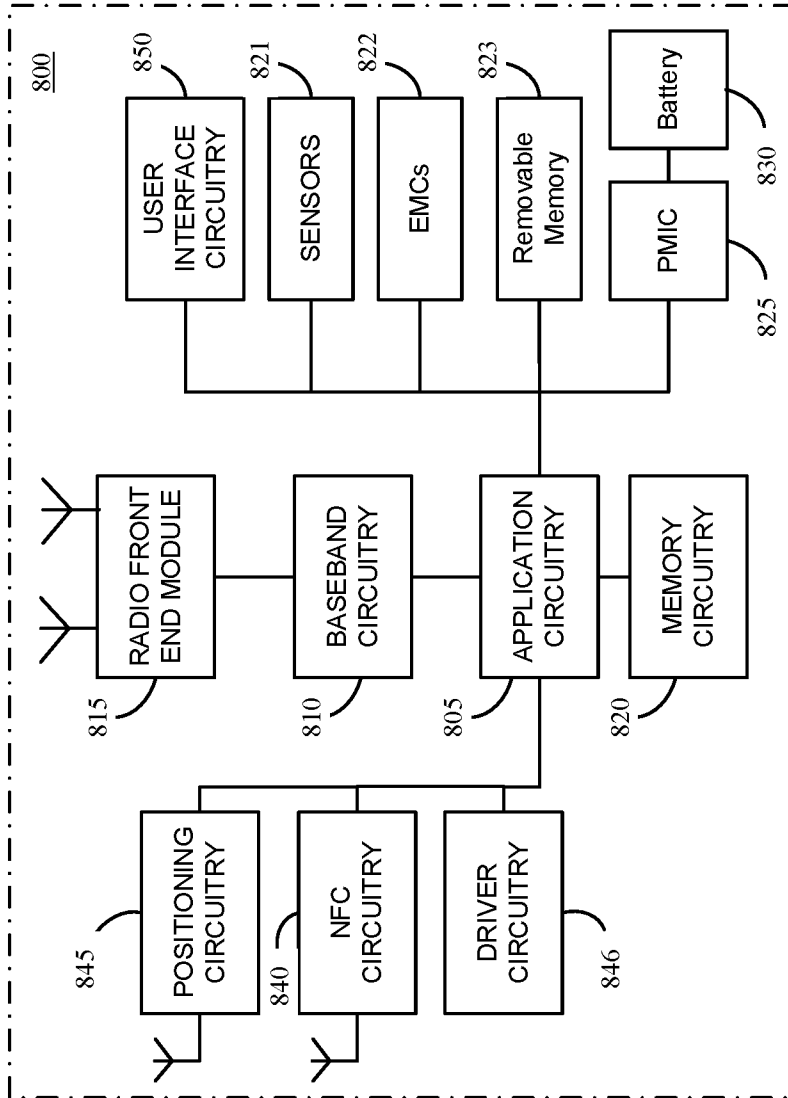

FIG. 8

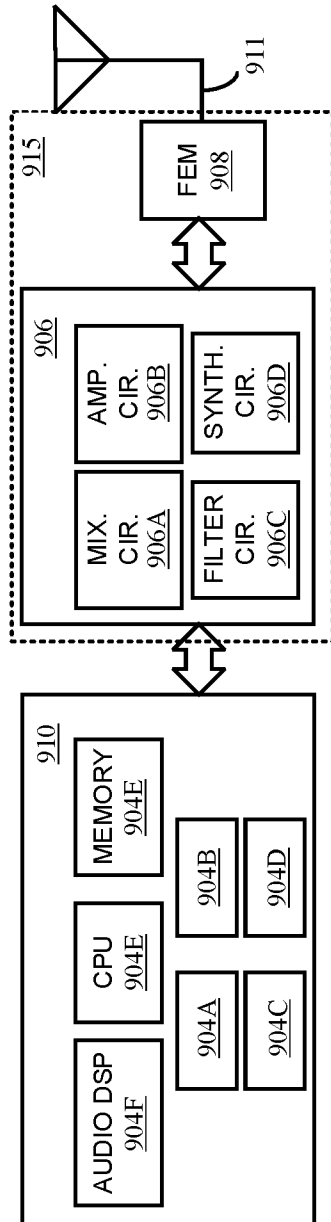

FIG. 9

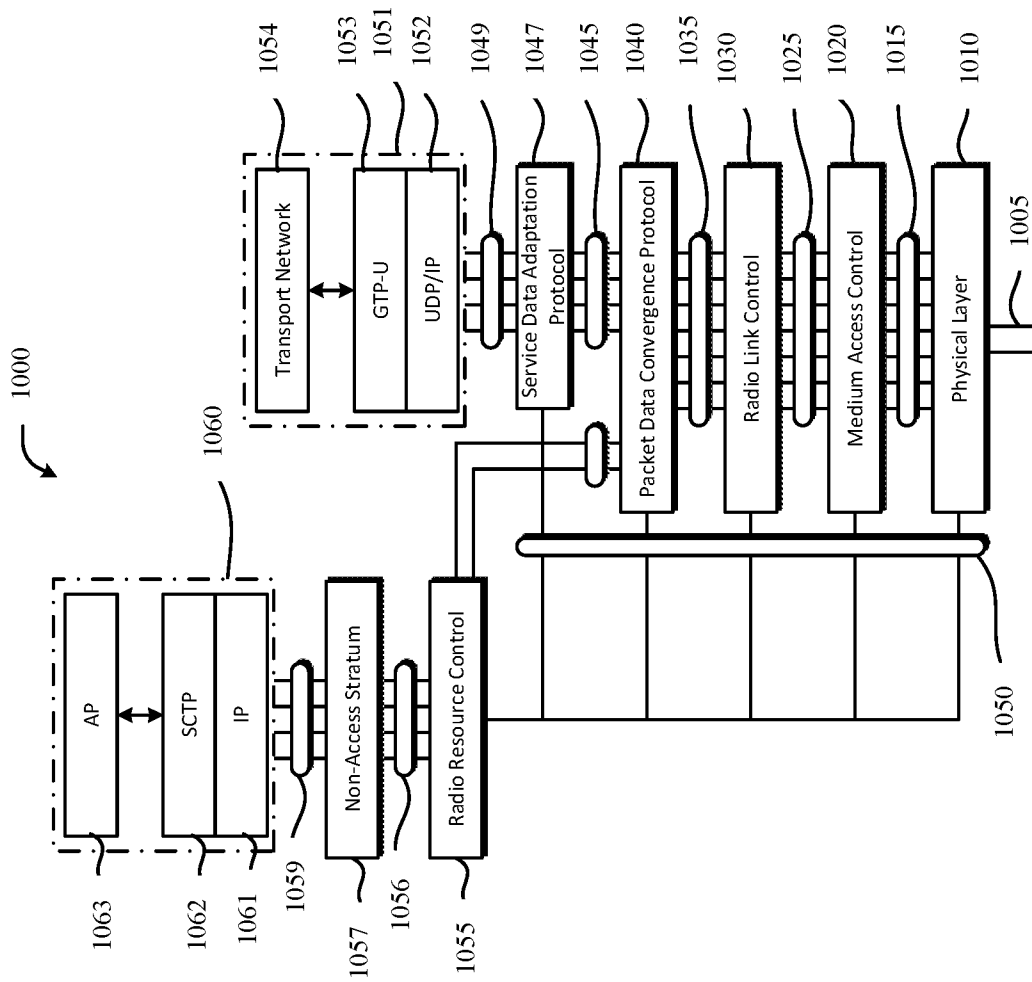

FIG. 10

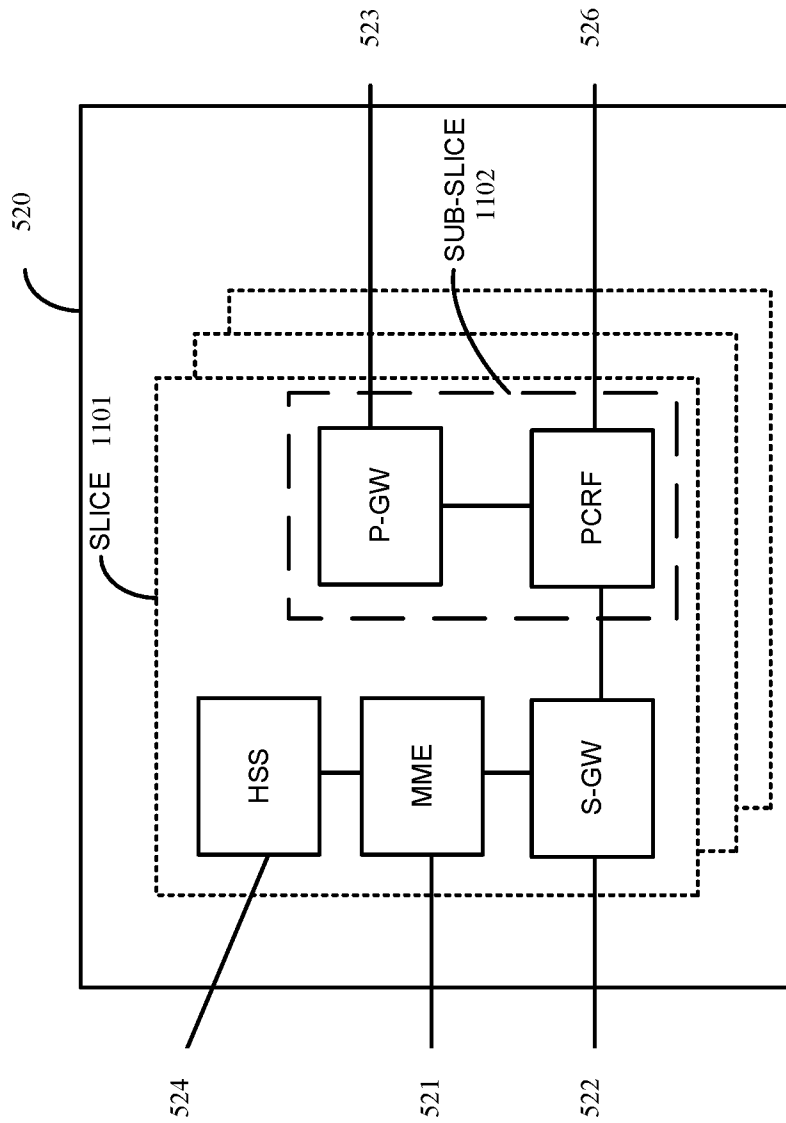

FIG. 11

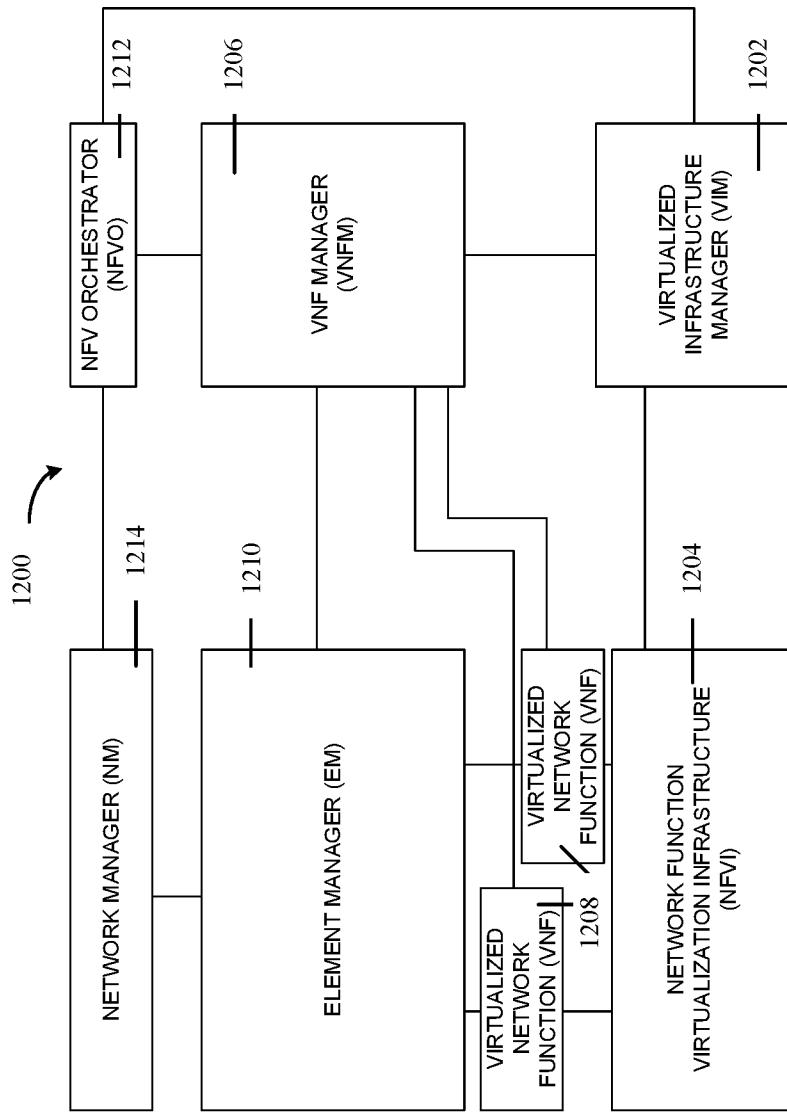

FIG. 12

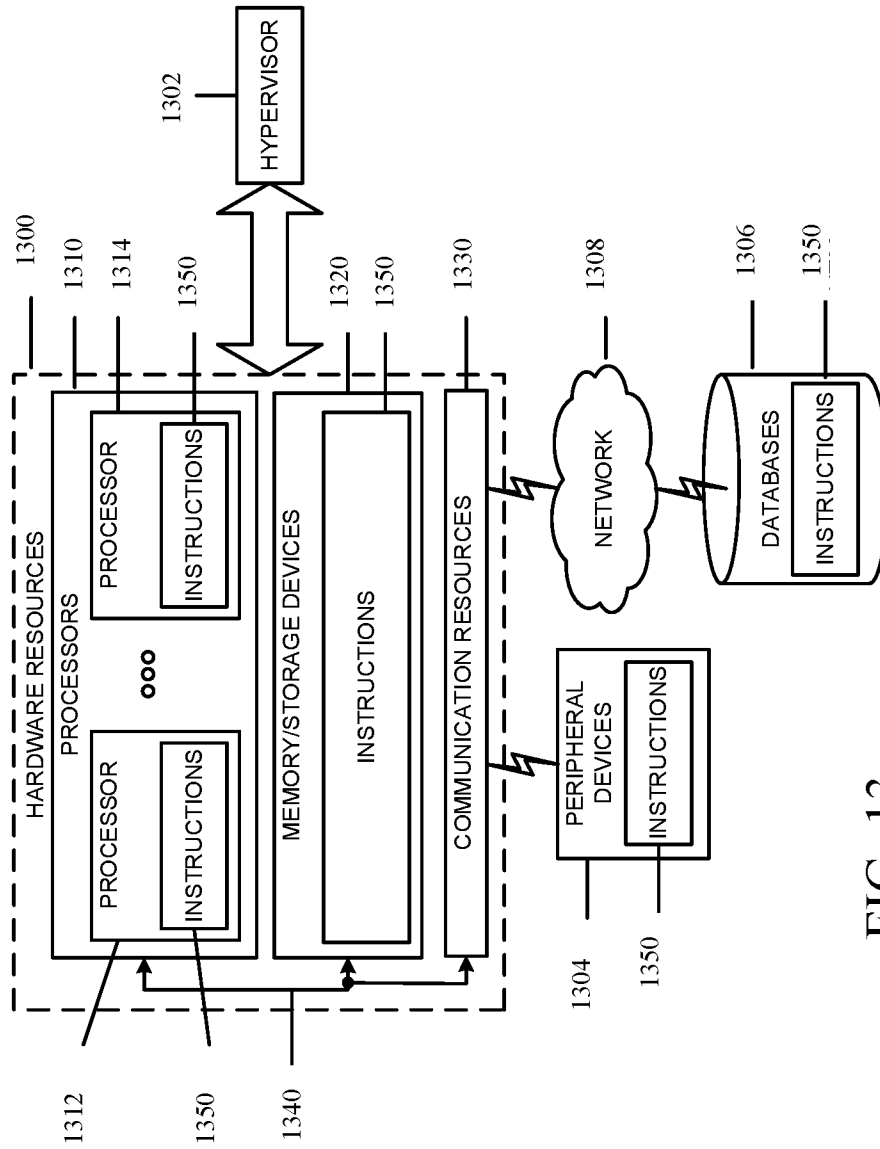

FIG. 13

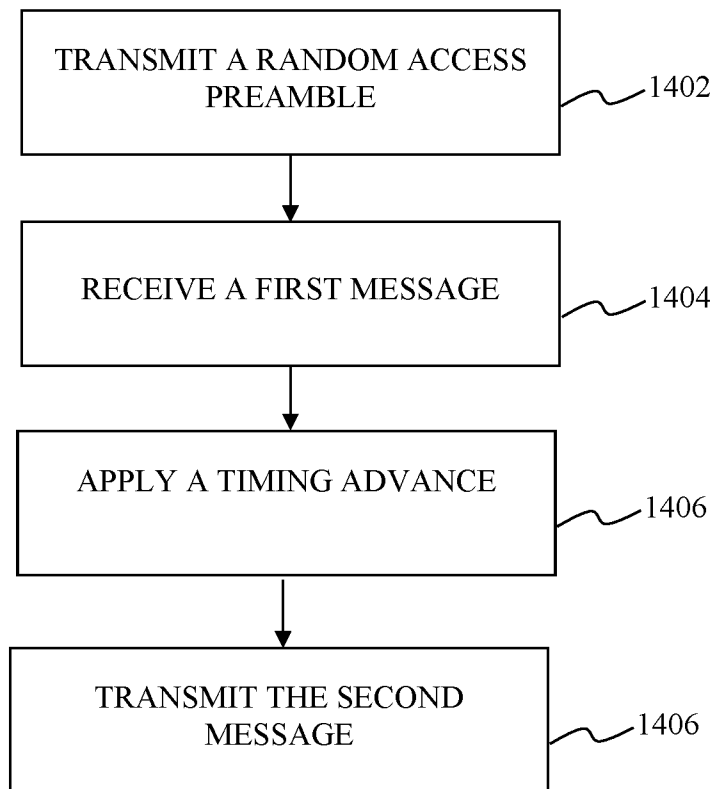

FIG. 14

INTERNATIONAL SEARCH REPORT

International application No  
PCT/US2020/015267

A. CLASSIFICATION OF SUBJECT MATTER  
 INV. H04L5/00 H04W56/00 H04W74/00 H04W74/08 H04B7/185  
 H04B7/26  
 ADD.  
 According to International Patent Classification (IPC) or to both national classification and IPC

B. FIELDS SEARCHED  
 Minimum documentation searched (classification system followed by classification symbols)  
 H04L H04W H04B

Documentation searched other than minimum documentation to the extent that such documents are included in the fields searched

Electronic data base consulted during the international search (name of data base and, where practicable, search terms used)  
 EPO-Internal, WPI Data

C. DOCUMENTS CONSIDERED TO BE RELEVANT

Category*	Citation of document, with indication, where appropriate, of the relevant passages	Relevant to claim No.
X	US 2013/058315 A1 (FEUERSAENGER MARTIN [DE] ET AL) 7 March 2013 (2013-03-07)	1-4, 6-11, 13-18,20
Y	paragraph [0113] - paragraph [0153] -----	5,12,19
Y	US 2018/316414 A9 (HUGHES NETWORK SYSTEMS LLC [US]) 1 November 2018 (2018-11-01) paragraph [0307] - paragraph [0312]; claim 1 -----	5,12,19
X	DE 10 2017 108428 A1 (BAYERISCHE MOTOREN WERKE AG [DE] ET AL.) 25 October 2018 (2018-10-25) paragraph [0199] - paragraph [0200] ----- -/--	1-4, 6-11, 13-18,20

Further documents are listed in the continuation of Box C.

See patent family annex.

\* Special categories of cited documents :

"A" document defining the general state of the art which is not considered to be of particular relevance	"T" later document published after the international filing date or priority date and not in conflict with the application but cited to understand the principle or theory underlying the invention
"E" earlier application or patent but published on or after the international filing date	"X" document of particular relevance; the claimed invention cannot be considered novel or cannot be considered to involve an inventive step when the document is taken alone
"L" document which may throw doubts on priority claim(s) or which is cited to establish the publication date of another citation or other special reason (as specified)	"Y" document of particular relevance; the claimed invention cannot be considered to involve an inventive step when the document is combined with one or more other such documents, such combination being obvious to a person skilled in the art
"O" document referring to an oral disclosure, use, exhibition or other means	"&" document member of the same patent family
"P" document published prior to the international filing date but later than the priority date claimed	

Date of the actual completion of the international search  4 May 2020	Date of mailing of the international search report  14/05/2020
---	--

Name and mailing address of the ISA/ European Patent Office, P.B. 5818 Patentlaan 2 NL - 2280 HV Rijswijk Tel. (+31-70) 340-2040, Fax: (+31-70) 340-3016	Authorized officer  Dupuis, Hervé
--	---

## INTERNATIONAL SEARCH REPORT

International application No  
PCT/US2020/015267

C(Continuation). DOCUMENTS CONSIDERED TO BE RELEVANT		
Category*	Citation of document, with indication, where appropriate, of the relevant passages	Relevant to claim No.
X	CA 2 725 771 A1 (LG ELECTRONICS INC [KR]) 23 December 2009 (2009-12-23)  paragraph [0119] - paragraph [0152] -----	1-4, 6-11, 13-18,20
X	EP 3 110 203 A1 (THALES SA [FR]) 28 December 2016 (2016-12-28)  paragraph [0098] -----	1-4, 6-11, 13-18,20
A	US 2018/241464 A1 (MICHAELS PARIS [AU]) 23 August 2018 (2018-08-23) claim 3  -----	5,12,19

# INTERNATIONAL SEARCH REPORT

Information on patent family members

International application No  
PCT/US2020/015267

Patent document cited in search report	Publication date	Patent family member(s)	Publication date	
US 2013058315	A1	07-03-2013	CN 102918896 A	06-02-2013
			CN 106851808 A	13-06-2017
			CY 1120771 T1	11-12-2019
			DK 2760241 T3	10-09-2018
			EP 2553986 A1	06-02-2013
			EP 2760241 A1	30-07-2014
			EP 3358890 A1	08-08-2018
			JP 5620569 B2	05-11-2014
			JP 2013529403 A	18-07-2013
			KR 20180072869 A	29-06-2018
			LT 2760241 T	10-09-2018
			PL 2760241 T3	31-12-2018
			SI 2760241 T1	30-10-2018
			US 2013058315 A1	07-03-2013
US 2015189675 A1	02-07-2015			
US 2016353393 A1	01-12-2016			
-----				
US 2018316414	A9	01-11-2018	NONE	
-----				
DE 102017108428	A1	25-10-2018	NONE	
-----				
CA 2725771	A1	23-12-2009	AU 2009261045 A1	23-12-2009
			CA 2722781 A1	23-12-2009
			CA 2725771 A1	23-12-2009
			CN 102067479 A	18-05-2011
			CN 102067704 A	18-05-2011
			CN 102067705 A	18-05-2011
			CN 104065409 A	24-09-2014
			CN 105472756 A	06-04-2016
			ES 2570938 T3	23-05-2016
			ES 2618503 T3	21-06-2017
			HK 1222969 A1	14-07-2017
			JP 5174960 B2	03-04-2013
			JP 5189204 B2	24-04-2013
			JP 5295365 B2	18-09-2013
			JP 5540066 B2	02-07-2014
			JP 5719058 B2	13-05-2015
			JP 2011524125 A	25-08-2011
			JP 2011524141 A	25-08-2011
			JP 2011524713 A	01-09-2011
			JP 2013102492 A	23-05-2013
			JP 2014195265 A	09-10-2014
			KR 20090131640 A	29-12-2009
			KR 20090131650 A	29-12-2009
KR 20090131651 A	29-12-2009			
US 2019289544 A1	19-09-2019			
-----				
EP 3110203	A1	28-12-2016	EP 3110203 A1	28-12-2016
			FR 3038201 A1	30-12-2016
-----				
US 2018241464	A1	23-08-2018	AU 2016347539 A1	21-06-2018
			CA 3003667 A1	04-05-2017
			GB 2571592 A	04-09-2019
			PH 12018550072 A1	28-01-2019
			US 2018241464 A1	23-08-2018
			WO 2017072745 A1	04-05-2017
-----				