

⑫ **EUROPEAN PATENT APPLICATION**

⑰ Application number: 81305717.1

⑤① Int. Cl.³: **H 05 B 6/68, H 05 B 6/80**

⑱ Date of filing: 03.12.81

⑳ Priority: 03.12.80 JP 171650/80

⑦① Applicant: **SHARP KABUSHIKI KAISHA,**
22-22 Nagaïke-cho Abeno-ku, Osaka 545 (JP)

④③ Date of publication of application: 09.06.82
Bulletin 82/23

⑦② Inventor: **Okuno, Takeshi, 816 Oaza-Meyasu**
Ikaruga-cho, Ikoma-gun Nara-ken (JP)

⑧④ Designated Contracting States: **DE FR GB SE**

⑦④ Representative: **Wright, Peter David John et al, R.G.C.**
Jenkins & Co. Chancery House 53-64 Chancery Lane,
London WC2A 1QU (GB)

⑤④ **Cooking apparatus.**

⑤⑦ A cooking apparatus, preferably a combined microwave and electric heater oven, includes a cassette tape player system (18) for reproducing digital data recorded on a magnetic cassette tape (15). The digital data includes a cooking constant which is determined for each of a plurality of cooking operations. A gas sensor (42) is disposed in the oven for detecting the concentration of reducing gas generated from a foodstuff being cooked. A digital control system (29) calculates a reference level from the cooking constant. The reference level is compared with an output of the gas sensor (42) for developing a control signal to terminate cooking when the output reaches the reference level.

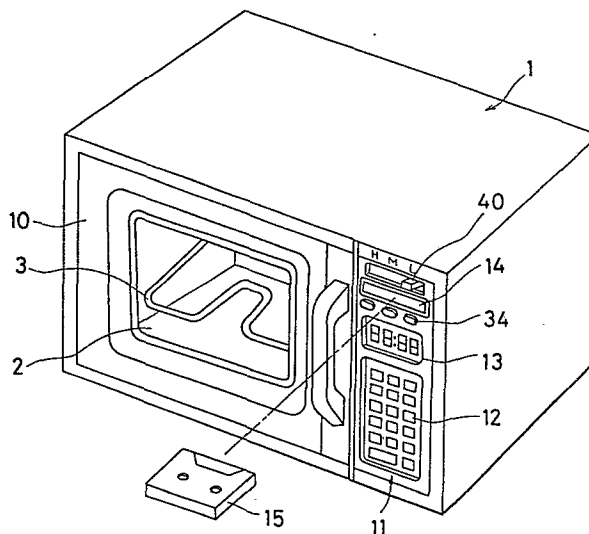

EP 0 053 523 A1

COOKING APPARATUS

FIELD OF INVENTION

The present invention relates to a cooking apparatus including a gas sensor having an output which is used to automatically control a cooking operation.

BACKGROUND ART

A gas sensor element having a resistance value which changes in response to the cooking condition of foodstuff disposed in a cooking apparatus has been developed. A microwave oven including a gas sensor element is described in our U.K. Patent Application No. 7930612, "COOKING UTENSIL CONTROLLED BY GAS SENSOR OUTPUT", published on August 28, 1980, the publication number being 2,040,502A.

In the above-mentioned microwave oven, the cooking sequence program is stored in a microcomputer system included in the microwave oven and, therefore, only a limited number of automatic cooking operations are performed. It was difficult to determine a suitable cooking constant, which determines the completion of cooking in combination with the output signal derived from the gas sensor element, for each of the various kinds of cooking operation.

On the other hand, a cooking apparatus has been developed which includes a cassette tape player system for audibly announcing an explanation concerning cooking. A microwave oven having a cassette tape player system is

described in our copending European Patent Application No. 80303308.3, "CASSETTE TAPE CONTROLLED COOKING APPARATUS", published on April 1, 1981, the publication number being 0.026,094 A2.

5 In the above-mentioned cassette tape controlled microwave oven, the cassette tape carries digital data for controlling the cooking operation in addition to the audio information for providing the audible announcement of an explanation concerning cooking. The digital data
10 includes time data for determining a cooking time period.

SUMMARY OF THE INVENTION

 According to one aspect of the invention, a cooking apparatus which has a control responsive to reproduced data relating to a cooking program for controlling the
15 cooking apparatus has a gas sensor the output of which is compared with a reference level determined by the reproduced data, the control being operable to terminate a cooking operation when the reference level has been reached.

 In a preferred embodiment of the present invention,
20 a cassette tape player system is included in a combination microwave and electric heater oven. A gas sensor is disposed in the combination microwave and electric heater oven for detecting the cooking condition of a foodstuff disposed in the combination microwave and electric heater
25 oven. The cassette tape carries a digital data related

to a cooking constant which determines the cooking completion condition for each of the cooking operation. The cooking constant data read by the cassette tape player system is stored in a control system included in the combination microwave and electric heater oven. The cooking constant data is used to obtain a reference level indicating the cooking completion condition, which is compared with an output signal derived from the gas sensor, whereby a cooking completion instruction signal is developed from

5

10

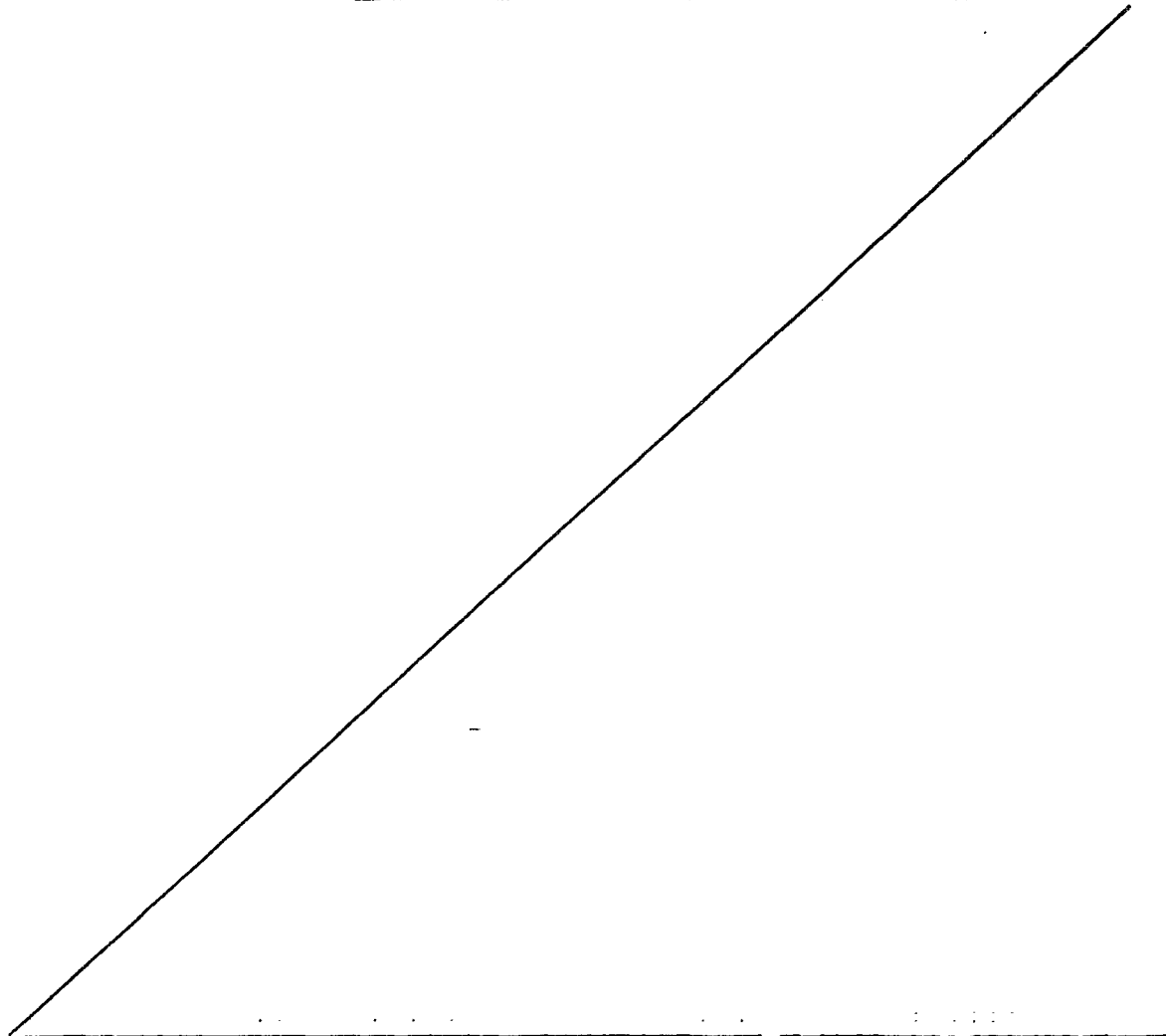

the control system when the output signal derived from the gas sensor reaches the reference level.

BRIEF DESCRIPTION OF THE DRAWINGS

The present invention will be better understood from the detailed description given hereinbelow and the accompanying drawings which are given by way of illustration only, and thus are not limitative of the present invention and wherein:

FIGURE 1 is a perspective view of an embodiment of a combination microwave and electric heater oven of the present invention;

FIGURE 2 is a sectional view of the combination microwave and electric heater oven of FIGURE 1;

FIGURE 3 is a block diagram of an embodiment of a control system included in the combination microwave and electric heater oven of FIGURE 1;

FIGURE 4 is a schematic chart for explaining a recording condition on a cassette tape which is loaded on a cassette tape player system included in the combined microwave and electric heater oven of FIGURE 1;

FIGURE 5 is a block diagram of an essential part of a digital control system included in the control system of FIGURE 3; and

FIGURE 6 is a graph for explaining an example of operation performed by the combination microwave and electric heater oven of FIGURE 1.

DESCRIPTION OF THE PREFERRED EMBODIMENTS

A combination microwave and electric heater oven of the present invention comprises a housing 1 and an oven cavity 2 surrounded by oven walls. A sheath heater 3 is disposed in the oven cavity 2 for grilling the foodstuff, and a magnetron 4 is secured to the oven wall for microwave cooking purposes. The microwave energy generated by the magnetron 4 is supplied to the oven cavity 2 through a waveguide 5. A power supply circuit comprising a high voltage transformer 6 and a condenser 7 is secured to the housing 1 for supplying the power to the magnetron 4. A blower fan motor 8 is associated with a blower fan 9 which functions to cool the magnetron 4.

An oven door 10 and a control panel 11 are disposed at the front face of the housing 1. The control panel 11 includes a keyboard panel 12, a digital display unit 13, a cassette tape inlet 14 for accommodating a cassette tape 15, and a heater position control knob 40 for adjusting the heater location in the oven cavity 2. The keyboard panel 12 is to introduce numeral information such as a set temperature and a set cook time

period, and cooking commands. That is, the keyboard panel 12 is an input unit for performing the digital controlled cooking operation. A typical construction of the digital controlled microwave oven is disclosed in U.S. Patent No. 4,255,639, "MICROWAVE OVEN WITH A PROGRAMMABLE DIGITAL CONTROL CIRCUIT", issued on March 10, 1981. The heater position control knob 40 is to select the heater height between "High", "Middle" and "Low". A typical construction for shifting the heater location in the oven cavity is shown and described in U.S. Patent No. 4,137,442, "HIGH-FREQUENCY OVEN HAVING A BROWNING UNIT", issued on Jan. 30, 1979.

Behind the control panel 11, a cassette tape player system 18 is disposed to confront the cassette tape inlet 14. The cassette tape player system 18 comprises a tape drive motor 16, and two magnetic reproduction heads 17_a and 17_b. A printed circuit board 19 is disposed behind the keyboard panel 12 for supporting the control circuit of the combination microwave and electric heater oven. First and second relays 20 and 21 are connected to the control circuit for controlling the operation of the magnetron 4 and the sheath heater 3, respectively. A speaker system 24 is associated with the cassette tape player system 18 for providing an audible explanation derived from the cassette tape player system 18. More specifically, cooking explanations are recorded on the cassette tape 15, and the tape drive motor 16 drives the cassette tape 15 at a desired timing for generating the audible explanation.

FIGURE 3 schematically shows a control system of the combination microwave and electric heater oven of the present invention. Like elements corresponding to those of FIGURES 1 and 2 are indicated by like numerals.

A capstan 25 is connected to the tape drive motor 16. When a pinch roller 26 is depressed toward the capstan 25, a magnetic tape 15_a is driven to travel in the direction shown by arrows in FIGURE 3 for reproduction purposes. The two magnetic reproduction heads 17_a and 17_b are made contact with two tracks recorded on the magnetic tape 15_a, respectively, for reproducing recorded information.

FIGURE 4 shows recording tracks on the magnetic tape 15_a. A first track 151 and a second track 152 are assigned to the forward direction drive, and a third track 153 and a fourth track 154 are assigned to the reverse direction drive. On the first and fourth tracks 151 and 154, audio information is recorded through the use of the analog recording technique for providing an audible cooking explanation. On the second and third tracks 152 and 153, digital information is recorded through the use of the saturation recording technique such as the phase encoding technique for providing a digital data which controls the cooking operation performed by the combination microwave and electric heater oven.

The magnetic reproduction head 17_a contacts the first track 151 or the fourth track 154. The audio information output reproduced from the

magnetic reproduction head 17_a is applied to an audio amplifier 27 for activating the speaker system 24. The magnetic reproduction head 17_b contacts the second track 152 or the third track 153. The digital information output derived from the magnetic reproduction head 17_b is introduced into a read-out amplifier 28, whereby the digital information output is converted into a binary code signal and applied to a digital control system 29.

The digital control system 29 comprises a central processor unit 291, a read only memory 292 and a random access memory 293. The binary code signal applied to the digital control system 29 is processed in the digital control system 29, thereby providing a control signal for controlling the operation of the combination microwave and electric heater oven in accordance with a preselected program sequence. A motor driver circuit 30 is associated with the digital control system 29 for driving the tape drive motor 16 at a desired timing. More specifically, the digital control system 29 develops a start signal for initiating the rotation of the tape drive motor 16, and a stop signal for terminating the rotation of the tape drive motor 16. A display driver circuit 31 is associated with the digital control system 29 for driving the digital display unit 13 in accordance with the digital display data derived from the magnetic reproduction head 17_b. More specifically, the digital display unit 13 is adopted to display the programmed cooking period or the programmed cooking condition in a digital fashion. A buzzer driver circuit 32 and a buzzer 33 are associated with the digital control system 29.

A tape start button 34 is disposed on the control panel 11 for controlling the cassette tape drive. When the tape start button 34 is actuated, the start signal is developed from the digital control system 29. The first relay 20 is associated with a first control switch 35 which is disposed between the high voltage transformer 6 and an AC power source 37. The high voltage transformer 6 functions, in combination with the condenser 7 and a diode 38, to energize the magnetron 4. The second relay 21 is associated with a second control switch 36 which is disposed between the sheath heater 3 and the AC power source 37. The relays 20 and 21 are controlled by control signals developed from the digital control system 29.

The combination microwave and electric heater oven of the present invention further comprises a gas sensor 42 of which a resistance value changes in response to the concentration of the gas developed from the foodstuff disposed in the combination microwave and electric heater oven. A preferred gas sensor is "TGS ~~8~~13" manufactured by Figaro Engineering Inc. A detection characteristic of the gas sensor 42 is described in the above copending U.K. Patent Application No. 7930612 (publication No. 2040502A).

The gas sensor 42 is connected to a resistance-to-frequency converter 43 implemented with an astable multi-vibrator. The frequency of an output signal derived from

tape player system 18 and the read out operation of the digital data recorded on the cassette tape 15. More specifically, the subprocessor 90 includes a first detection unit 92 for reading out a cooking constant A, a second detection unit 94 for reading out an additive cooking coefficient N, a first power detection unit 96 for reading out a microwave power data in the main cooking operation, and a second power detection unit 98 for reading out a microwave power data in an additive cooking operation.

The main processor 50 comprises a first comparactor 52 which functions to compare the output signal derived from the resistance-to-frequency converter 43 with a reference level determined in the main processor 50 and to develop a first control signal when the output signal frequency of the resistance-to-frequency converter 43 reaches the reference level. A second comparator 54 is included in the main processor 50, which develops a second control signal when the additive cooking operation is performed for a preselected period of time.

An operation mode of the digital control system 29 will be described with reference to the FIGURE 5 block diagram and an output frequency variation shown in FIGURE 6.

When the cook start instruction is developed in the microwave cooking mode, the combination microwave and electric heater oven is first placed in a cooling period t_0 . The gas sensor 42 detects the concentration of the gas within the oven cavity. The frequency of the output signal developed

from the resistance-to-frequency converter 43 varies as shown in FIGURE 6 in response to the variation of the detected gas concentration. The main processor 50 includes a minimum frequency memory 56 for storing a minimum frequency F_0 during the cooling period t_0 .

As already discussed above, a detection frequency F_1 derived from the resistance-to-frequency converter 43 varies in response to the detected gas concentration. The cooking constant A recorded on the cassette tape 15 and read out by the first detection unit 92 included in the subprocessor 90 is introduced into a reference level calculation unit 58 included in the main processor 50. The reference level calculation unit 58 calculates a reference level $A \cdot F_0$ through the use of the minimum frequency F_0 obtained in the minimum frequency memory 56. The thus obtained reference level $A \cdot F_0$ is introduced into and stored in a reference level memory 60 included in the main processor 50.

The microwave cooking is conducted at the microwave power determined by the first power detection unit 96. When the detection frequency F_1 detected by an output frequency detection unit 62 reaches the reference level $A \cdot F_0$ contained in the reference level memory 60, the first comparactor 52 develops the first control signal toward a cooking control signal generator 64 in order to terminate the main cooking.

A period counter 66 and a timepiece 68 are included in the main processor 50 for detecting a main cooking period T_1 . The combination microwave

and electric heater oven of the present invention is constructed to conduct an additive cooking at a microwave power read by the second power detection unit 98 for a preselected period of time T_2 . More specifically, the main processor 50 includes an additive cooking period calculation unit 70 which functions to calculate the additive cooking period T_2 in response to the main cooking period T_1 obtained in the period counter 66 and the additive cooking coefficient N recorded on the cassette tape 15 and read by the second detection unit 92. In a preferred form, a modification factor ΔN is introduced, at an operator's choice, from the keyboard panel 12 into the additive cooking period calculation unit 70. The additive cooking period T_2 is determined in accordance with the following equation.

$$T_2 = T_1 \times (N \pm \Delta N)$$

When the additive cooking is performed for the additive cooking period T_2 , the second comparator 54 develops the second control signal to terminate the additive cooking operation.

In a preferred form, the main processor 50 is implemented with a microprocessor "IX2058YA" manufactured by Sharp Corporation, and the subprocessor 90 is implemented with a microprocessor "IX2057YA" manufactured by Sharp Corporation.

The invention being thus described, it will be obvious that the same may be varied in many ways. Such variations are not to be regarded as a departure from the spirit and scope of the invention, and all such modifications are intended to be included within the scope of the following claims.

CLAIMS:

15

1. A cooking apparatus comprising:
 - a heat source for performing a cooking operation;
 - a sensor element for detecting a cooking condition performed by said heat source;
 - reproducing means for reproducing a digital data recorded on an information means, said digital data including a cooking constant;
 - calculation means for calculating a reference level through the use of said cooking constant recorded on said information means and read by said reproducing means;
 - comparing means for comparing an output signal derived from said sensor element with said reference level and developing a control signal when said output signal derived from said sensor element reaches said reference level; and
 - control means for controlling the operation of said heat source in response to said control signal developed from said comparing means.
2. The cooking apparatus of claim 1, wherein said reproducing means comprises a cassette tape player system and said information means comprises a magnetic cassette tape.
3. The cooking apparatus of claim 2, wherein said magnetic cassette tape carries audio information for providing audible cooking instructions, said cooking apparatus further comprising:

audio reproduction means for reproducing said audio information recorded on said magnetic cassette tape.

4. A microwave oven comprising:
 - a housing including an oven cavity and a cavity closure door;
 - microwave generating means for supplying microwave energy to said oven cavity for performing a cooking operation;
 - a sensor element for detecting a cooking condition performed in said oven cavity;
 - reproduction means for reproducing a digital data recorded on an information means, said digital data including a cooking constant;
 - calculation means for calculating a reference level through the use of said cooking constant recorded on said information means and read by said reproduction means;
 - comparing means for comparing an output signal derived from said sensor element with said reference level and developing a control signal when said output signal derived from said sensor element reaches said reference level; and
 - control means for controlling the operation of said microwave generating means in response to said control signal developed from said comparing means.

5. The microwave oven of claim 4, wherein said sensor element comprises a gas sensor for detecting a concentration of reducing gas generated in said oven cavity.

6. The microwave oven of claim 5, further comprising:
 - a resistance-to-frequency converter for developing a detection signal of which frequency varies in response to a variation of a resistance value of said gas sensor, and wherein
 - said detection signal is applied to said comparing means for comparison purposes.

7. The microwave oven of claim 4, 5 or 6, wherein said control means includes:
 - an additive cooking control unit for conducting an additive cooking for a preselected period of time after said control signal is developed from said comparing means.

8. The microwave oven of claim 7, wherein said digital data includes:
 - a first coefficient for determining a microwave power in said additive cooking; and
 - a second coefficient for determining said preselected period of time.

9. The microwave oven of claim 7, wherein said reproduction means comprises a cassette tape player system and said information means comprises a magnetic cassette tape.

10. The microwave oven of claim 9, wherein said magnetic cassette tape carries audio information recorded thereon for providing audible cooking instructions, said microwave oven further comprising:
 - audio reproduction means for reproducing said audio information recorded on said magnetic cassette tape.

11. A cooking apparatus having means (18) for reproducing stored data relating to a selected program of cooking operations, and a control (29) responsive to the reproduced data for controlling the cooking apparatus, characterised by a sensor (42) which produces an output signal indicative of the condition of food being cooked by the apparatus, and further characterised in that the control (29) is responsive to said output signal reaching a value corresponding to a reference level represented by said reproduced data for terminating a cooking operation.

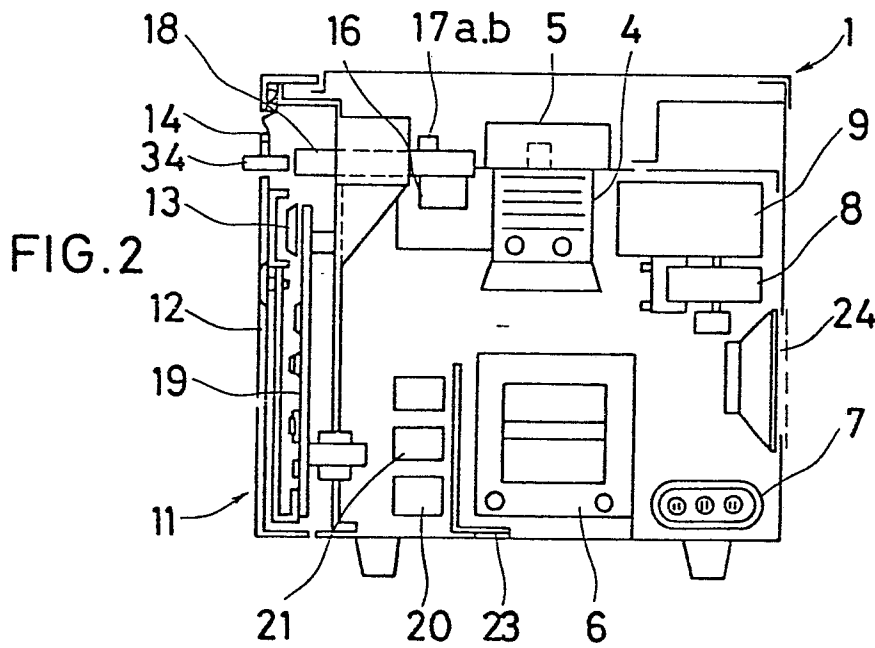
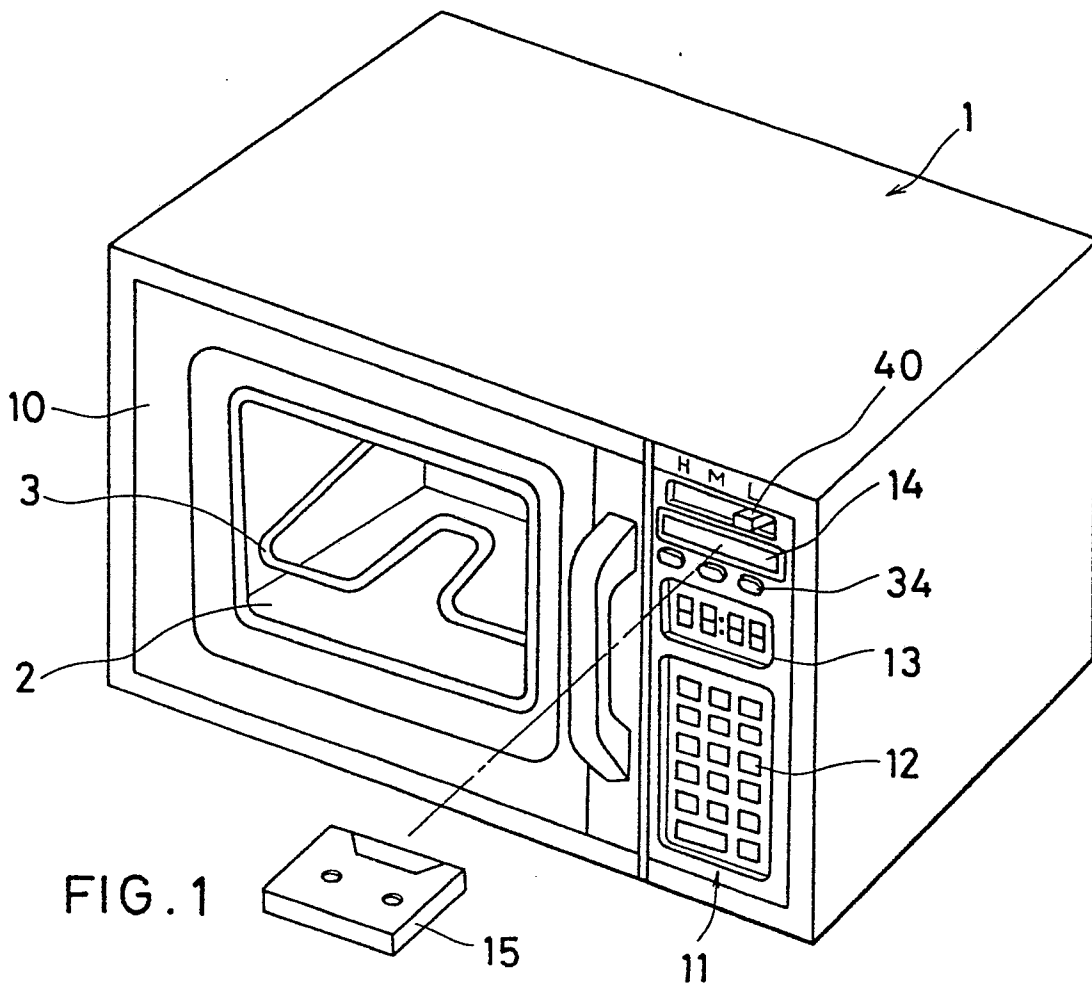

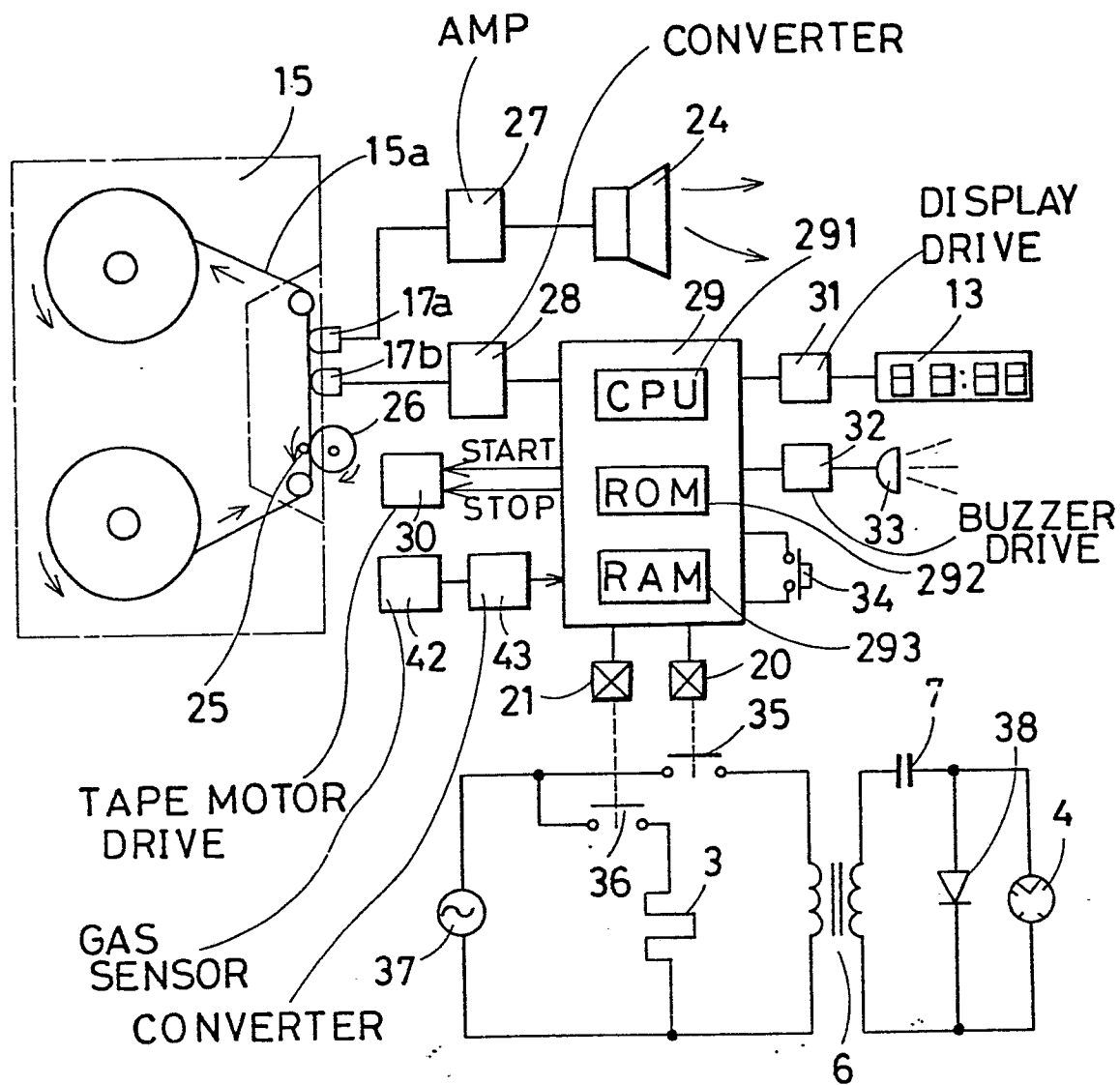

FIG. 3

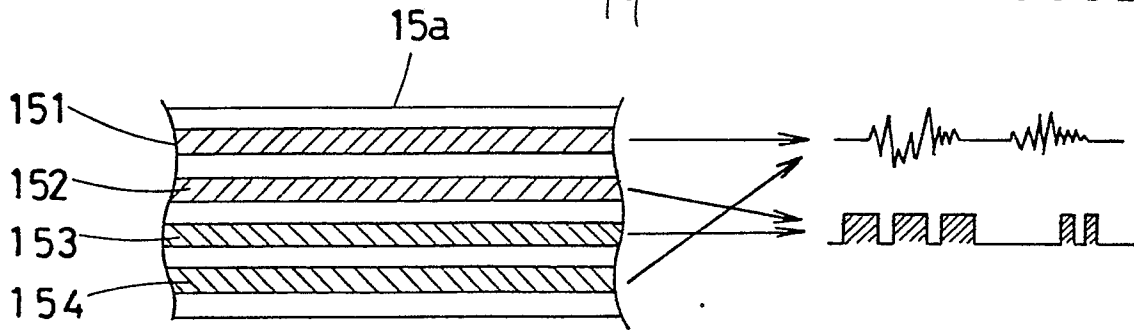

FIG. 4

OUT PUT FREQUENCY FROM RESISTANCE-TO-FREQUENCY CONVERTER -43-

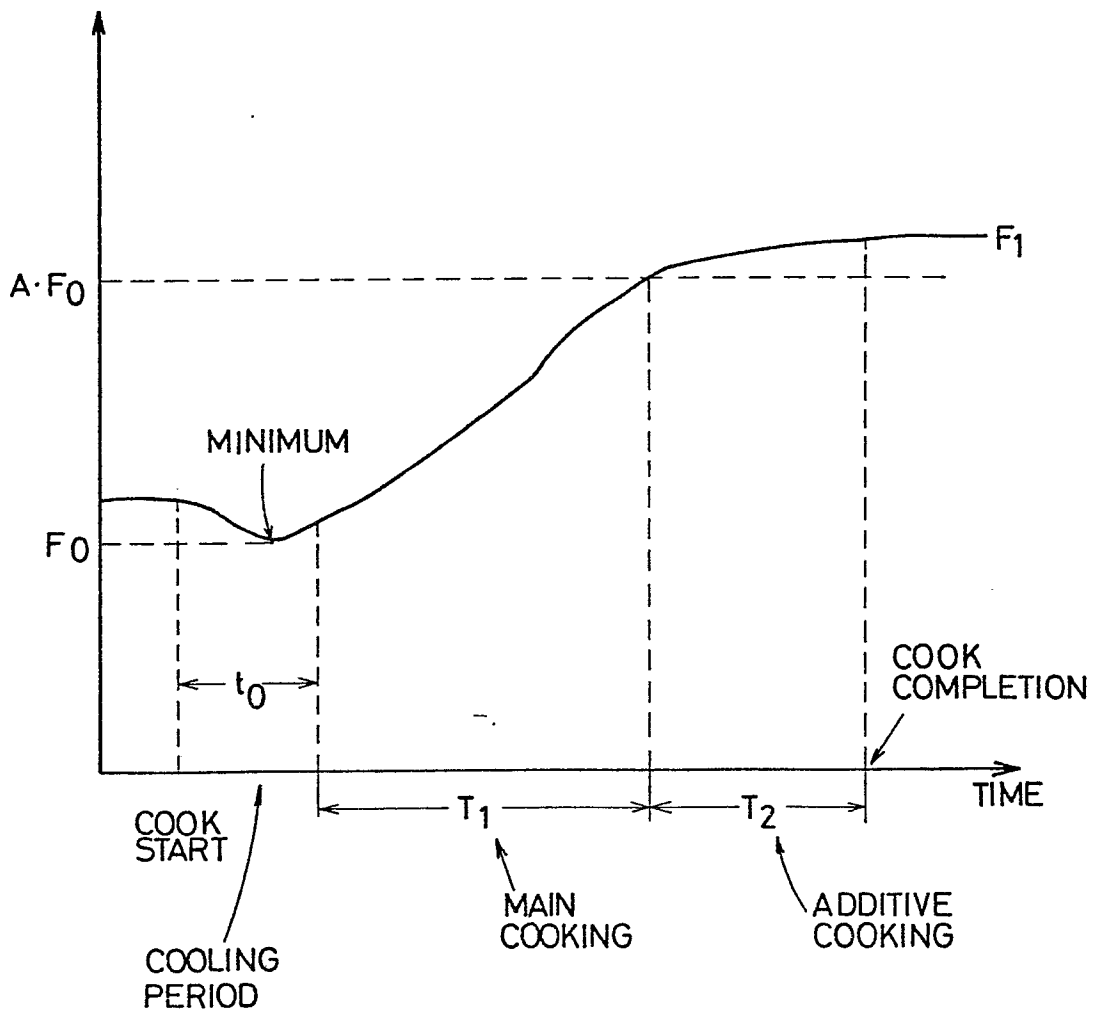

FIG. 6

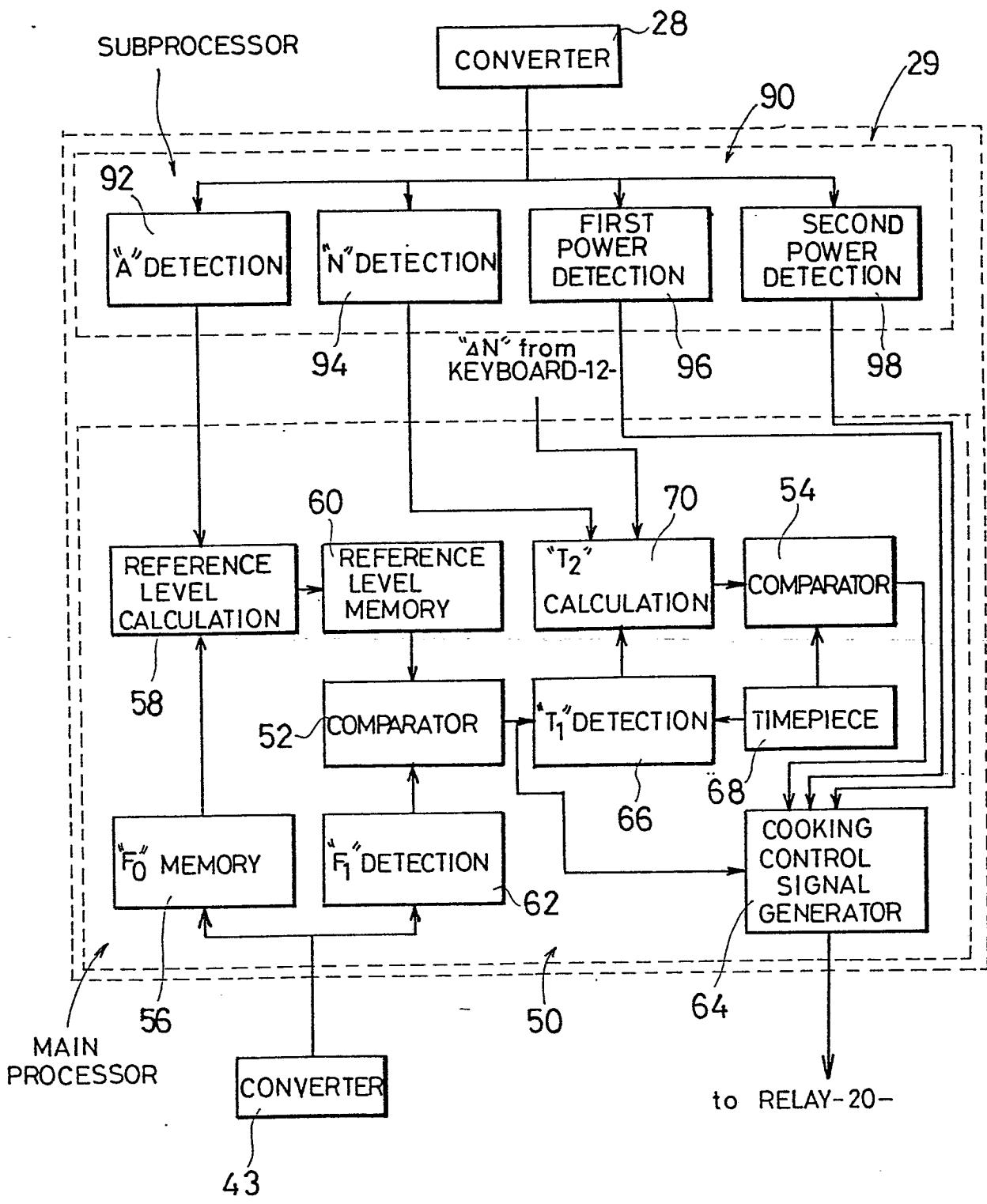

FIG. 5
(DIGITAL CONTROL SYSTEM -29-)



DOCUMENTS CONSIDERED TO BE RELEVANT		CLASSIFICATION OF THE APPLICATION (Int. Cl. 3)	
Category	Citation of document with indication, where appropriate, of relevant passages	Relevant to claim	
X	<u>GB - A - 2 026 726</u> (NODA) * page 9, lines 106 to 119; figures 21,29 * ---	1,4,7	H 05 B 6/68 6/80
A	<u>DE - A - 2 832 434</u> (MATSUSHITA) * page 9, line 4 to page 10, line 8; figure 3 * & GB - A - 2 002 143 ---	1,4,6	
			TECHNICAL FIELDS SEARCHED (Int.Cl. 3)
A	<u>EP - A - 0 017 749</u> (DORINA) * page 3, lines 14 to 27; page 4, lines 6 to 10; page 5, line 10 to page 6, line 17 * ---	2,3,9	H 05 B 6/00 F 24 C G 05 B
A	<u>US - A - 3 173 335</u> (BATEMAN) * column 1, lines 26 to 38, 62 to 64 * ---	2,3,9	
A	<u>FR - A - 2 053 129</u> (BOWMAR/TIC)		
A	<u>EP - A - 0 000 957</u> (LITTON) -----		
			CATEGORY OF CITED DOCUMENTS
			X: particularly relevant if taken alone Y: particularly relevant if combined with another document of the same category A: technological background O: non-written disclosure P: intermediate document T: theory or principle underlying the invention E: earlier patent document, but published on, or after the filing date D: document cited in the application L: document cited for other reasons
			&: member of the same patent family, corresponding document
<input checked="" type="checkbox"/>	The present search report has been drawn up for all claims		
Place of search	Date of completion of the search	Examiner	
The Hague	02-03-1982	RAUSCH	