

No. 763,361.

PATENTED JUNE 28, 1904.

A. J. BRIGGS & J. B. SITTS.  
MACHINE FOR THRESHING PEAS.

APPLICATION FILED SEPT. 2, 1902.

NO MODEL.

4 SHEETS—SHEET 1.

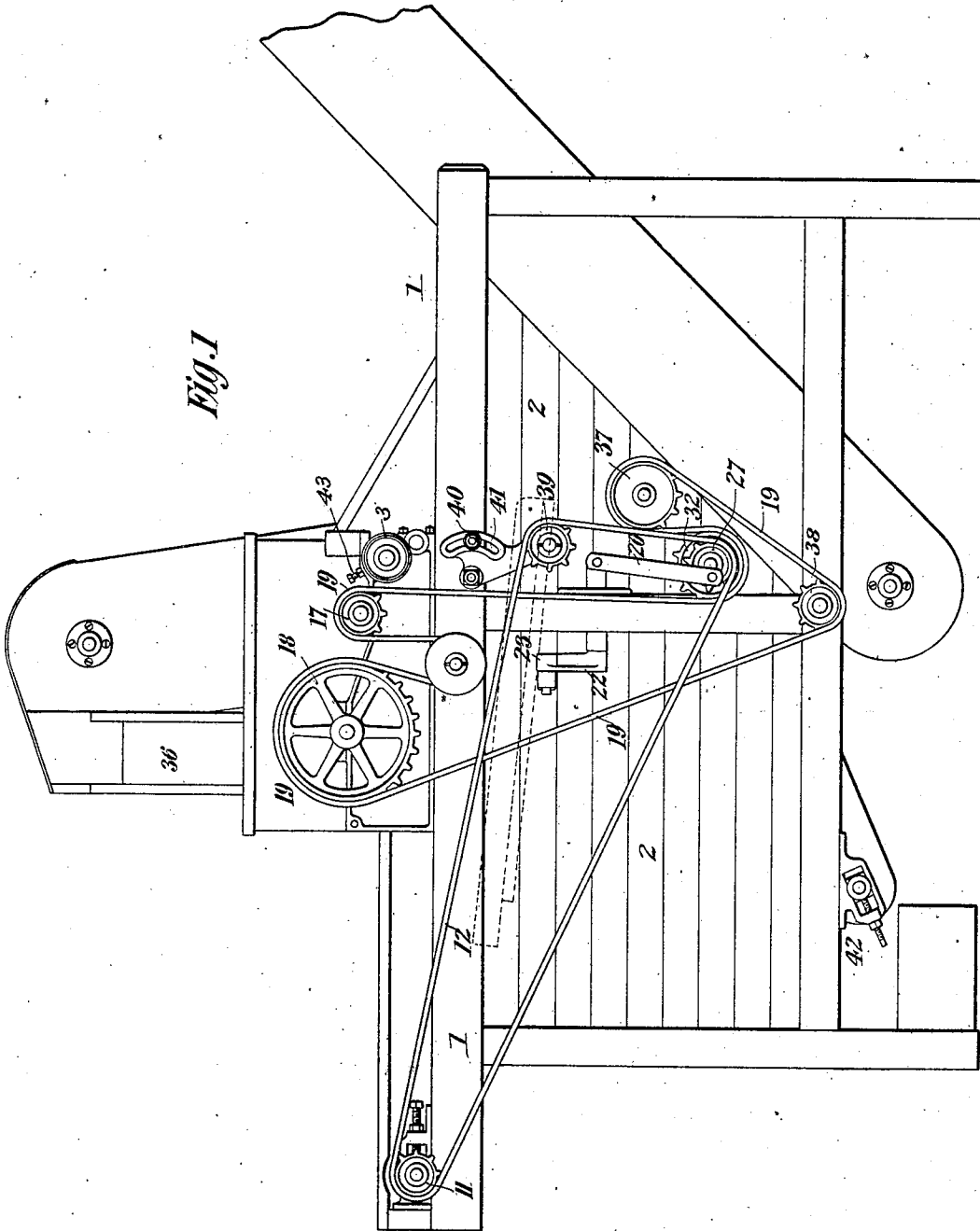

Witnesses:  
*Raphael Ketter*  
*A. Dunham*

Inventors  
*Arthur J. Briggs*  
*and Jacob B. Sitts.*  
by *Kerr, Page & Cooper Att'ys.*

No. 763,361.

PATENTED JUNE 28, 1904.

A. J. BRIGGS & J. B. SITTS.  
MACHINE FOR THRESHING PEAS.

APPLICATION FILED SEPT. 2, 1902.

NO MODEL.

4 SHEETS—SHEET 2.

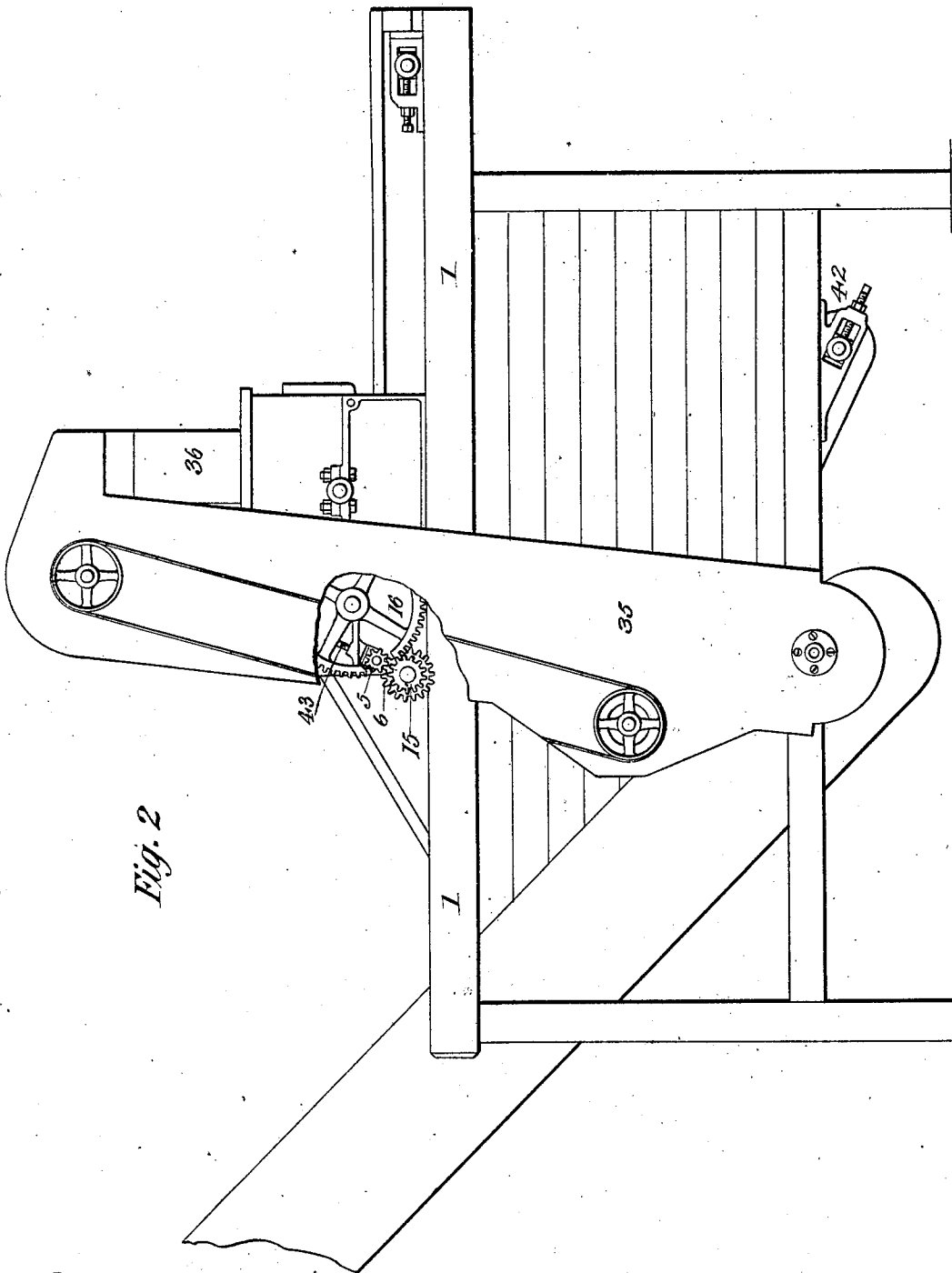

Fig. 2

Witnesses:

*Raphael M. ...*

*A. Dunham.*

Inventors:

*Arthur J. Briggs  
and Jacob B. Sitts.*

*by Kerr, Page & Cooper Attys.*

A. J. BRIGGS & J. B. SITTS.  
MACHINE FOR THRESHING PEAS.  
APPLICATION FILED SEPT. 2, 1902.

NO MODEL.

4 SHEETS—SHEET 3.

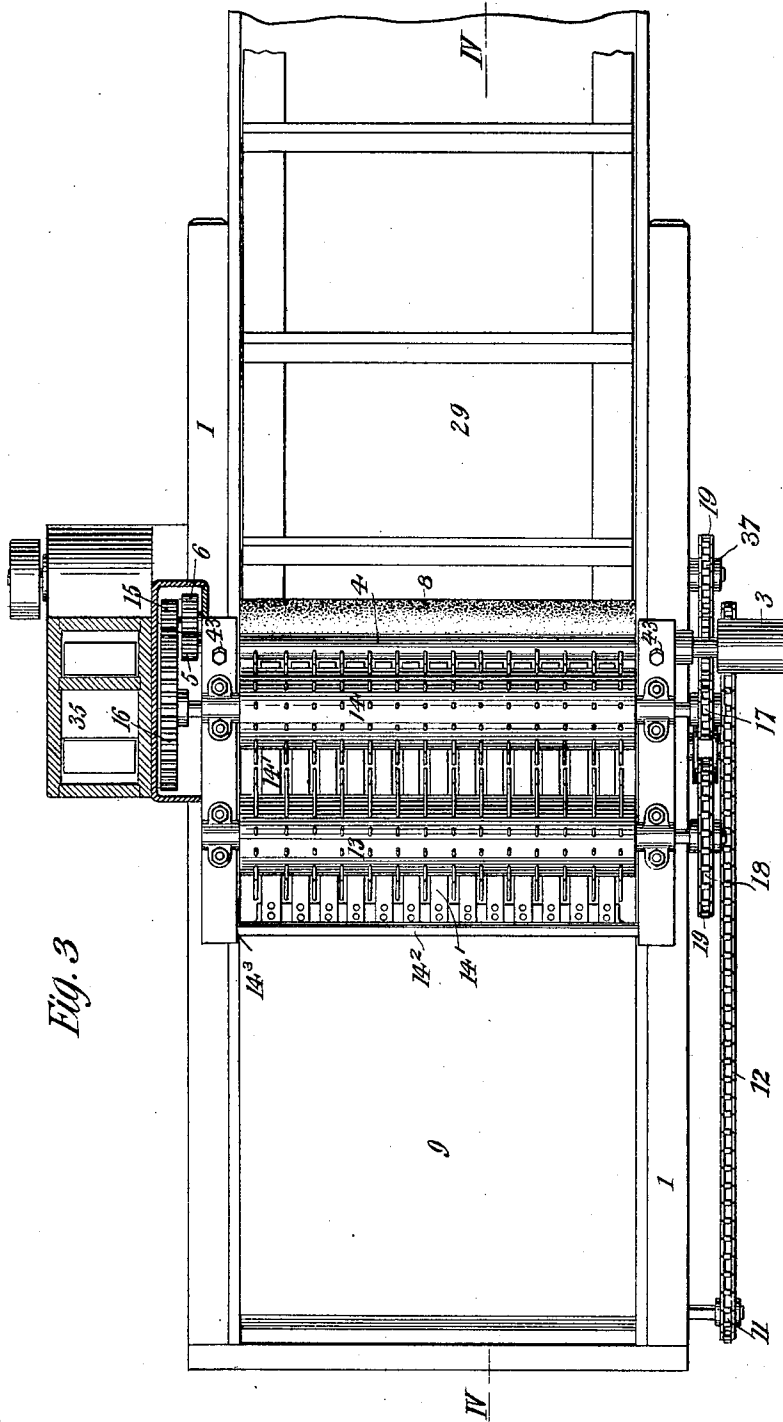

Fig. 3

Witnesses:  
Raphael Ketter  
S. S. Dunham.

Inventors  
Arthur J. Briggs  
and Jacob B. Sitts

by Kurt, Page & Cooper Att'ys

A. J. BRIGGS & J. B. SITTS.  
MACHINE FOR THRESHING PEAS.

APPLICATION FILED SEPT. 2, 1902.

NO MODEL.

4 SHEETS—SHEET 4.

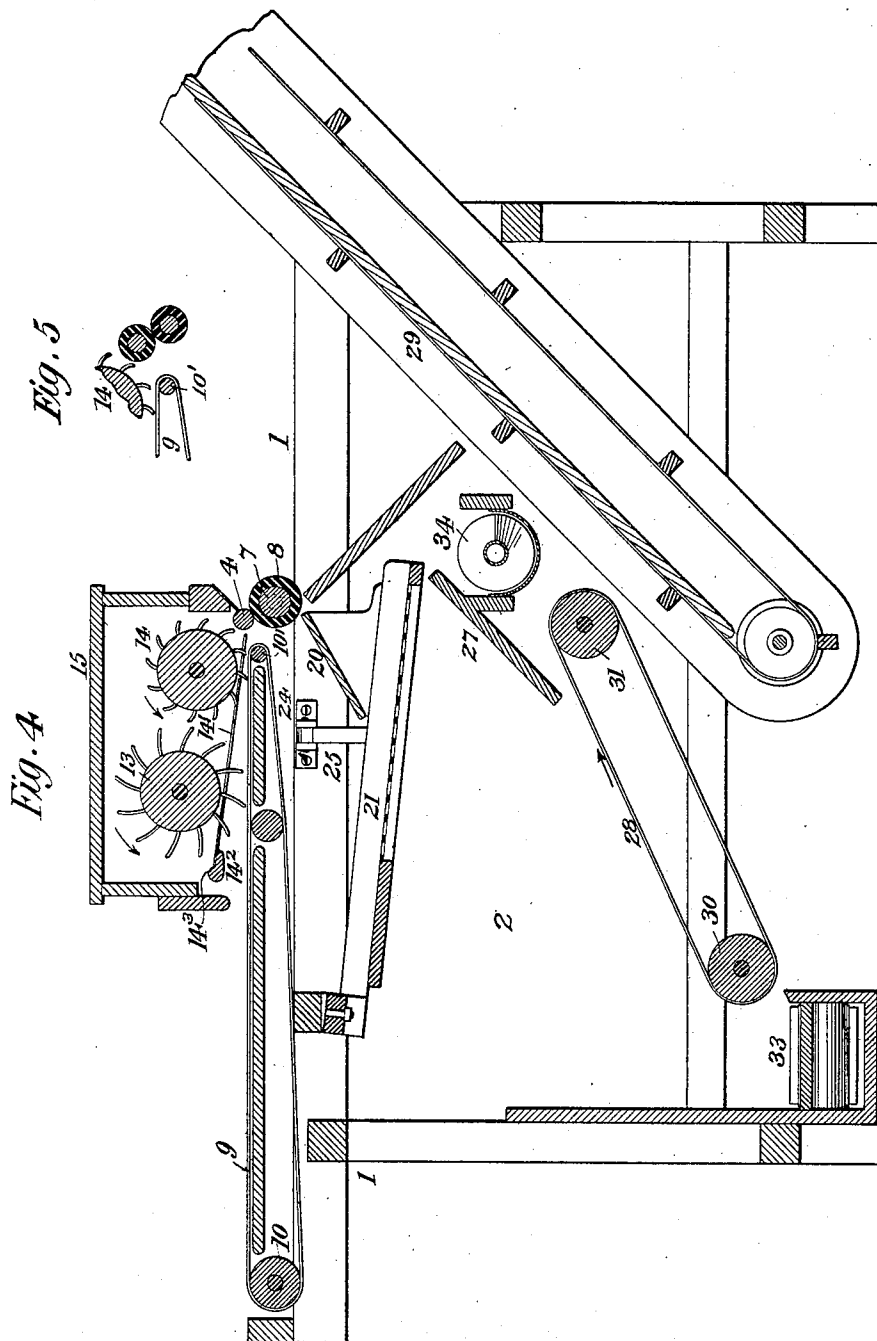

Witnesses:  
*Raphael Ketter*  
*A. Dunham*

Inventors:  
*Arthur J. Briggs*  
*and Jacob B. Sitts.*  
 by *Herb. Page & Cooper. Attys*

# UNITED STATES PATENT OFFICE.

ARTHUR JAMES BRIGGS, OF CANASTOTA, AND JACOB BUSH SITTS, OF WAMPSVILLE, NEW YORK, ASSIGNORS OF ONE-THIRD TO JOHN W. SOUTER, OF CANASTOTA, NEW YORK.

## MACHINE FOR THRESHING PEAS.

SPECIFICATION forming part of Letters Patent No. 763,361, dated June 28, 1904.

Application filed September 2, 1902. Serial No. 121,764. (No model.)

*To all whom it may concern:*

Be it known that we, ARTHUR JAMES BRIGGS, residing at Canastota, and JACOB BUSH SITTS, residing at Wampsville, county of Madison, State of New York, both citizens of the United States, have invented certain new and useful Improvements in Machines for Threshing Peas, of which the following is a specification, reference being had to the drawings accompanying and forming part of the same.

Our invention consists, essentially, in means for separating peas from the pods and vines by passing the same through suitable rollers driven at suitable speed, whereby the pods and vines pass through the rollers while peas do not; in a feeding mechanism whereby the vines are fed to the rollers in a comparatively thin layer to prevent clogging, and in cleaning mechanism by which unbroken pods are returned to the rollers to be acted upon. Numerous attempts, more or less successful, have been made to accomplish the ends just mentioned; but none of them has proven entirely satisfactory in use. We have therefore been led to our present invention, which we find operates positively and with practically no waste whatever.

In the drawings, Figure 1 represents a side elevation of a convenient form of our thresher. Fig. 2 is an elevation of the other side. Fig. 3 is a top plan view, certain parts being removed to show the spike feed-rolls and the threshing-rollers. Fig. 4 is a section on line IV IV, and Fig. 5 is a modification of the threshing-rollers.

In the machine illustrated in the drawings, 1 is a suitable framework, of wood or other material, which supports the working parts of the machine. The frame has side walls 2.

Extending across the upper part of the machine at a convenient point is a shaft bearing at one end the driving-pulley 3. The shaft itself constitutes a roller 4 and may be smooth or slightly corrugated to facilitate the feed of the vines, as will be understood from the description to follow. On the other end of the shaft or roller 4 is a gear-wheel 5, meshing

with a gear 6 on a second shaft parallel to the first, bearing a roller 7. The last-mentioned roller is covered with a layer of soft rubber 8. If now, the rollers being driven from the pulley 3, pea-vines bearing pods are fed into them, the peas will be taken out or separated in the following manner: The vines and pods are carried through, bedding themselves, as it were, in the soft rubber 8. The peas, however, from their size and contour are not caught and passed through, but instead are resisted by the rubber, and hence drop before the same into a receptacle below. It should be understood that the pods are broken open, so that the peas may be separated therefrom by the pressure of the peas therein against the inside of the pods when they are caught by the rollers, as well as by the mere crushing action of the rollers.

We are aware that separating-rollers covered with rubber have been proposed prior to our present invention, and we do not claim such broadly. Our rollers are mounted in immovable bearings, whereas those of the prior art are mounted in spring-bearings, so as to yield as the material passes through them. We have found that by making the soft-rubber covering of considerable thickness, as shown in Figs. 4 and 5 of the drawings, the pods and vines will bed themselves in and leave the unoccupied parts of the rollers in contact; but if the rollers are mounted on springs, so as to be forced apart by material passing through them, the unoccupied parts of the rollers will not be in contact and they will consequently either clog or allow the peas to go through without being forced from the pods.

As means for feeding the vines to the separators 4 8 we provide an endless apron 9, passing over rolls 10 and 10'. The latter, 10', is rotated to move the belt by means of a sprocket 11 on one end, over which works a chain 12, passing also over sprockets hereinafter to be described. It is clear, however, that if the roll 11 is rotated so as to advance the upper part of the apron toward the separators vines laid thereon will be carried to the same.

It is obviously desirable that the vines should be fed in a uniform layer, as otherwise the machine might be clogged or its operation rendered less effective by the bunching of the material. To effect this uniformity of feed, we provide spike-rollers 13 14, journaled in a housing 15, as shown, the action of the spikes or fingers being to separate the vines and direct them evenly into the rollers 4 and 7. To prevent the vines from being carried up between the rollers 13 14, fingers 14' are provided, arranged as shown in Figs. 3 and 4, secured to a head 14<sup>2</sup>, which is pivoted at 14<sup>3</sup> to permit the fingers 14' to play up and down freely. As the peas are separated from the pods and vines they fall on the inclined table 20 and roll thence on the screen 21. This latter is made with meshes of a size to permit the largest of the peas to pass readily through; but unbroken pods which have become detached from the vines before the latter reaches the separators and which consequently fall with the peas on the screen, bits of vine, and other refuse are retained thereon. Vibratory motion is given to the screen to facilitate the cleaning just described by means of the crank-lever 22, connected at its extremity 23 to the screen, which is pivoted in the casing of the apparatus at 24 and suspended from flexible supports, one of which is shown at 25, Fig. 4. The crank 22, pivoted in the frame, as shown, is provided with an arm extending outward at substantially a right angle from the casing, which is connected by a pitman 26 to a crank-sprocket, as illustrated, Fig. 1, so that the revolution of the latter by means of the chain 19 will oscillate the arm 22 and vibrate the screen 21. The shelled peas having passed through the screen 21 fall on the inclined surface 27, thence to the endless apron 28 moving in the direction of the arrow. The peas being round roll down this inclined apron, while the chaff and dirt are carried up until the apron begins to descend, when they fall into the conveyer 29, which carries them away, with the vines, from the separators 4 and 7. The endless apron 28 is driven over the rollers 30 31 by the rotation of 31, which carries a sprocket 32, Fig. 1. Over this latter passes the chain 19, which receives its motion, it will be remembered, from the sprocket 17 on one of the spike-rollers. As the peas roll down the apron 28, as before explained, they fall into a conveyer 33, by which they are carried to any desired receptacle.

The material remaining on the screen 21 after the shelled peas pass through the same, as unbroken pods, is shaken off into a screw conveyer 34, whence it is carried to an elevator 35, which carries it up to the chute 36, discharging it on the feeding-apron 9, after which it is again brought to the separators, as will be readily understood. The screw conveyer 34 is actuated by its sprocket 37, which is rotated by the chain 19. The eleva-

tor 35 is driven over its rollers by the sprocket 38 and chain 19, as will be clearly seen in Figs. 1 and 2.

The chain 12, which drives the feed-apron 9, may be tightened by means of the swinging idler 39, as will be readily understood, the latter being held in adjusted position by the bolt and nut 40 in the slot 41. The endless apron 28 may be tightened by separating its rollers, the lower one of which, 30, is held in sliding bearings with screw-adjusting means, as shown at 42, Fig. 1.

The operation of our thresher has already been explained in connection with the description of its mechanism. It might be further explained, however, that the action of the separating-rollers is that of squeezing the peas from the pods, an action made possible by the nature of the interior of the pods, which is very smooth and to a certain extent oily. It is obvious that to produce the best results the separating-rollers should be accurately arranged with reference to their distance from each other, and to easily effect this accurate adjustment one of them, as 4, is preferably mounted in adjustable bearings of any suitable and convenient kind. The screw by which roller 4 may be separated from or advanced toward the other is shown at 43, Fig. 1.

In the modification shown in Fig. 5 both separating-rollers are covered with rubber. This construction operates in the same manner as the foregoing; but we find that the use of one rubber-covered roller gives results which are perfectly satisfactory, and we therefore prefer the latter.

The size of the rollers can of course be varied considerably without affecting the efficient operation of the machine.

While we have described the machine illustrated as a pea-thresher, it is of course adapted equally well to shell beans and other podded vegetables or fruits, and we therefore do not wish to be understood as being limited to the use which we have set forth in detail.

What we claim as our invention is—

1. In a machine of the kind described, the combination with separating-rollers, of an inclined table having its upper end arranged immediately below the rollers, a vibrating screen below said table, a conveyer at the lower end of the screen to receive unbroken pods and the like which are shaken therefrom and return the same to the rollers, an inclined table below the screen to receive the peas passing therethrough, an inclined, upwardly-moving apron below the last-mentioned table, down which apron the peas roll, a conveyer at the lower end, a table inclined oppositely to the first, arranged with its upper end immediately below the rollers, upon which the vines are discharged from the rollers, and a conveyer arranged adjacent the lower end of the last-mentioned table and the upper end of the inclined apron, to receive

the vines from the former and the dirt and chaff from the latter, as and for the purposes set forth.

2. In a machine of the kind described, the  
5 combination with separating-rollers, and a vibrating screen to separate the peas from unbroken pods operatively arranged below the rollers, of an upwardly-moving inclined  
10 apron on which the peas fall from the screen, and a conveyer at the lower end of the apron to receive the peas as they roll therefrom, as and for the purposes set forth.

3. In a machine of the kind described, the combination with a vibrating screen, an up-

wardly-moving inclined apron below the vi- 15  
brating screen, and a conveyer at the lower end of the apron, of a separating-roller covered with a thick layer of soft rubber, a co-  
acting device, said roller and coacting device 20  
being maintained in fixed relation to each other, and means for feeding unthreshed pods to the roller and coacting device, as and for the purposes set forth.

ARTHUR JAMES BRIGGS.  
JACOB BUSH SITTS.

Witnesses:

S. M. WING,  
EDWIN A. BRIDGE.