



US00D347958S

# United States Patent [19]

[11] Patent Number: **Des. 347,958**

Kelly et al.

[45] Date of Patent: **\*\* Jun. 21, 1994**

[54] **ACTIVITY BOARD**

[75] Inventors: **Ray G. Kelly; Sharon A. Turnbough,**  
both of St. Louis, Mo.

[73] Assignee: **Angeles Group, Inc.,** Pacific, Mo.

[\*\*] Term: **14 Years**

[21] Appl. No.: **10,342**

[22] Filed: **Jul. 6, 1993**

**Related U.S. Application Data**

[62] Division of Ser. No. 4,551, Feb. 8, 1993, Pat. No. Des. 341,976, which is a division of Ser. No. 635,338, Dec. 28, 1990, abandoned.

[52] U.S. Cl. .... **D6/573**

[58] Field of Search ..... **D6/512, 552-553, D6/567, 572-574; 211/86-88, 90, 126, 134, 162; 248/201, 218.4, 219.1, 230, 231, 231.8, 235**

[56] **References Cited**

**U.S. PATENT DOCUMENTS**

D. 141,423 5/1945 Lewis ..... **D6/573**  
D. 297,149 8/1988 Johnston ..... **D6/573 X**  
1,262,493 4/1918 Hilgeman et al. .... **D6/573 X**

*Primary Examiner*—Brian N. Vinson  
*Attorney, Agent, or Firm*—Paul M. Denk

[57] **CLAIM**

The ornamental design for an activity board, as shown and described.

**DESCRIPTION**

FIG. 1 is a top, front, and left side perspective view of an activity board showing our new design; FIG. 2 is a rear elevational view thereof; FIG. 3 is a front elevational view thereof; FIG. 4 is a left side elevational view thereof, the right side being a mirror image of that shown; FIG. 5 is a top plan view thereof; FIG. 6 is a bottom plan view thereof; FIG. 7 is a top, front, and left side perspective view of an alternate embodiment of an activity board showing our new design; FIG. 8 is a rear elevational view thereof; FIG. 9 is a front elevational view thereof; FIG. 10 is a left side elevational view thereof, the right side being a mirror image of that shown; FIG. 11 is a top plan view thereof; and, FIG. 12 is a bottom plan view thereof.

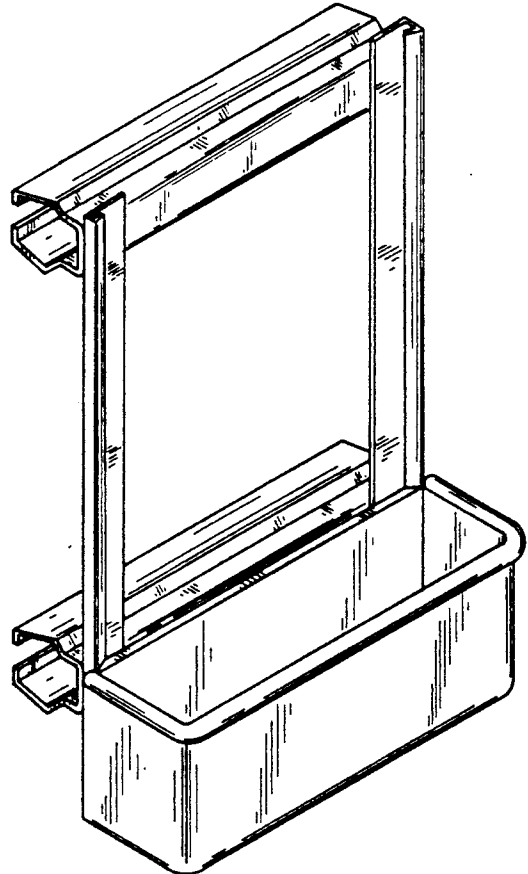
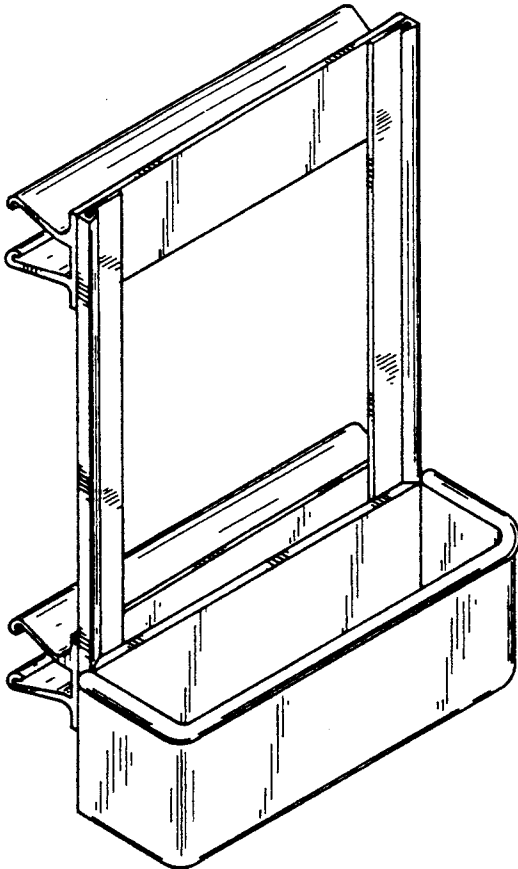

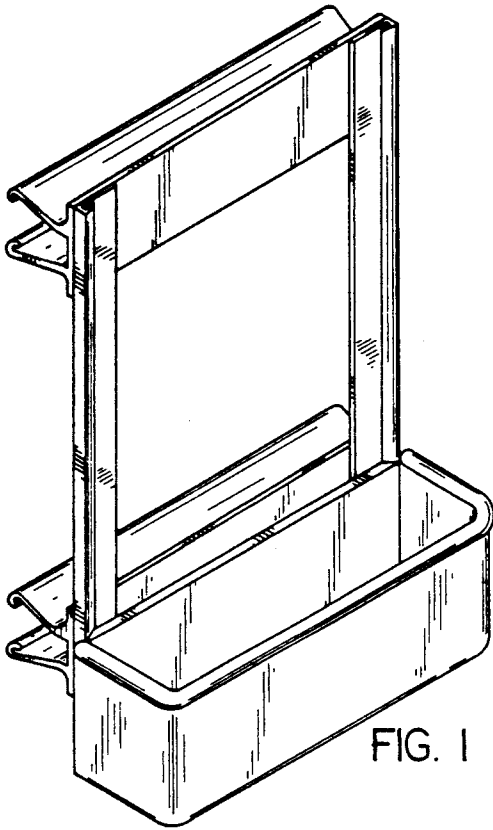

FIG. 1

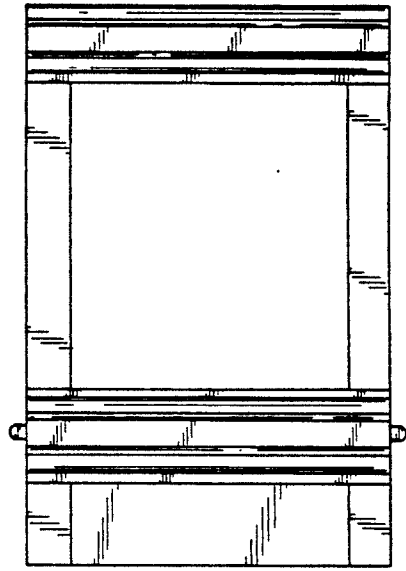

FIG. 2

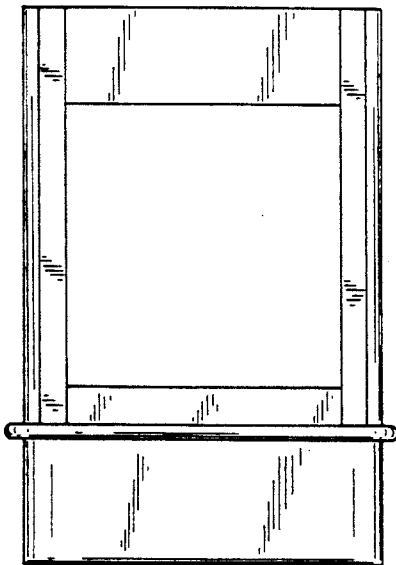

FIG. 3

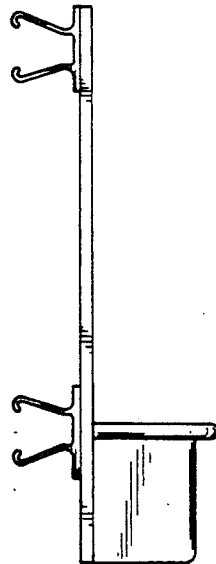

FIG. 4

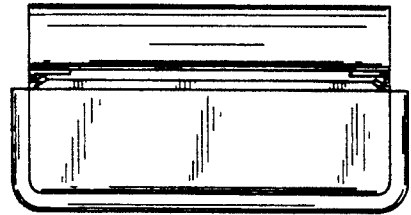

FIG. 5

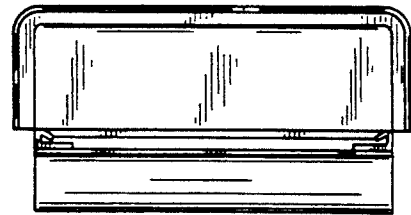

FIG. 6

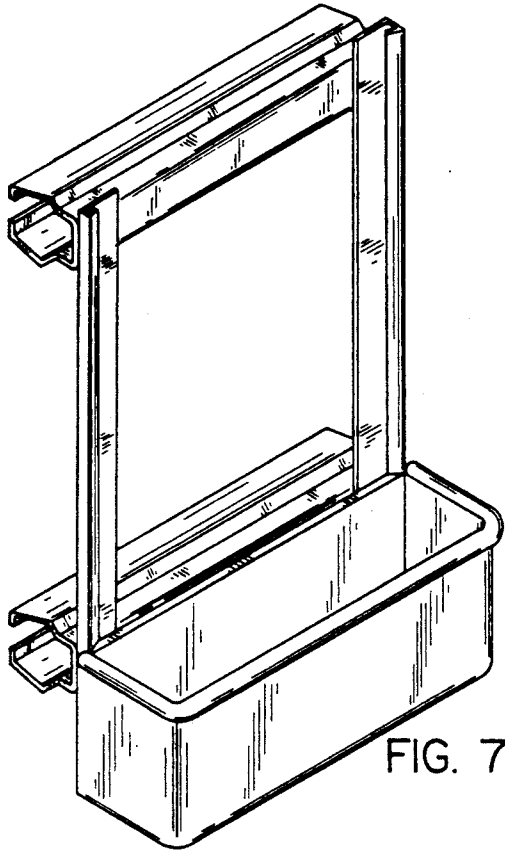

FIG. 7

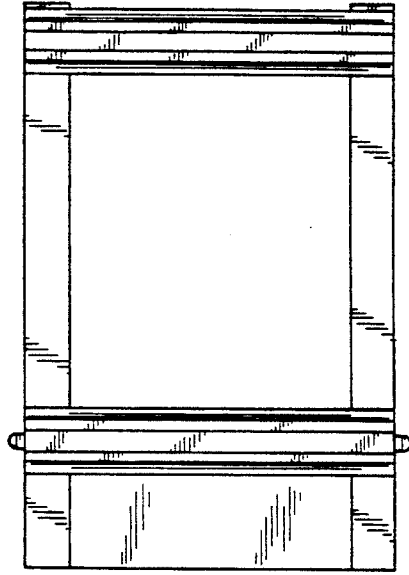

FIG. 8

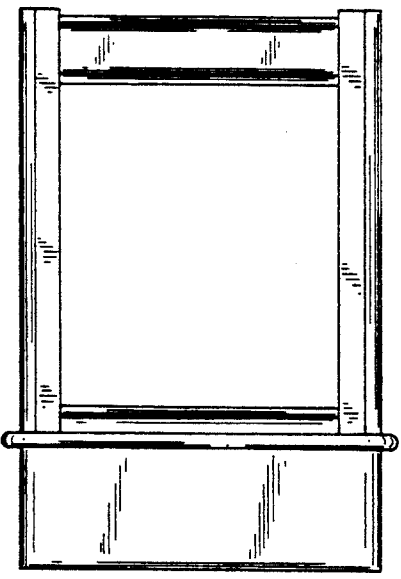

FIG. 9

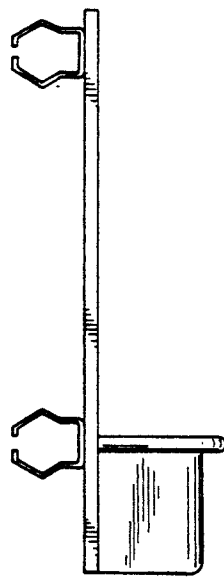

FIG. 10

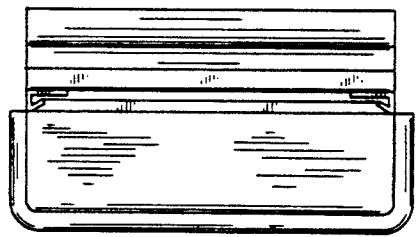

FIG. 11

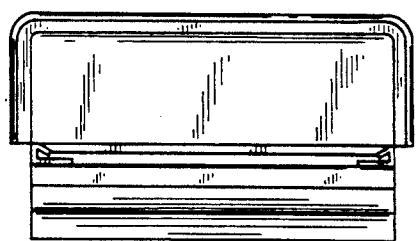

FIG. 12