



US 20090053732A1

(19) **United States**

(12) **Patent Application Publication**
Vermesh et al.

(10) **Pub. No.: US 2009/0053732 A1**

(43) **Pub. Date: Feb. 26, 2009**

(54) **MICROFLUIDIC DEVICES, METHODS AND SYSTEMS FOR DETECTING TARGET MOLECULES**

Publication Classification

(51) **Int. Cl.**
G01N 33/53 (2006.01)
C12M 1/34 (2006.01)

(76) **Inventors:** **Ophir Vermesh**, Los Angeles, CA (US); **Brian K.H. Yen**, Pasadena, CA (US); **James R. Heath**, South Pasadena, CA (US)

(52) **U.S. Cl.** **435/7.1; 435/287.1; 435/287.2**

Correspondence Address:

Steinfl & Bruno
301 N Lake Ave Ste 810
Pasadena, CA 91101 (US)

(21) **Appl. No.:** **12/174,598**

(22) **Filed:** **Jul. 16, 2008**

Related U.S. Application Data

(60) Provisional application No. 60/959,666, filed on Jul. 16, 2007, provisional application No. 60/998,981, filed on Oct. 15, 2007.

(57) **ABSTRACT**

Microfluidic devices methods and systems for detecting a target in a fluidic component of a sample are shown. In such devices, methods and systems, the flow resistance of various channels where the sample is introduced is adjusted to control separation of the fluidic component from the sample and/or performance of assays for the detection of the target in the fluidic component in a controlled fashion. Such performance is controlled by binding affinity of the target with capture agents or diffusion of the target in the fluidic component.

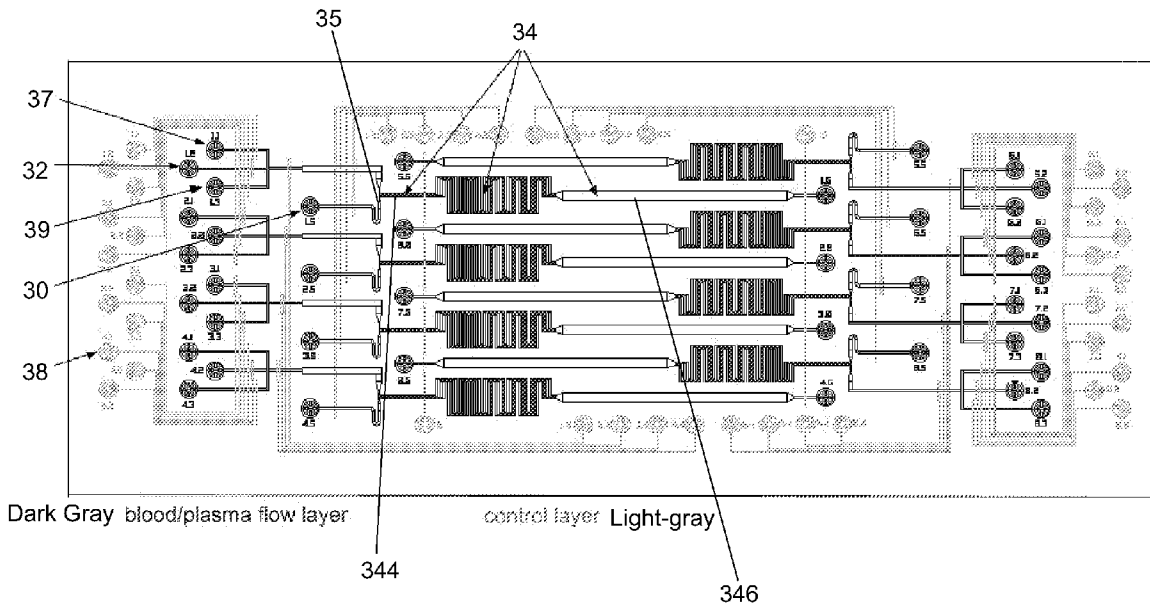

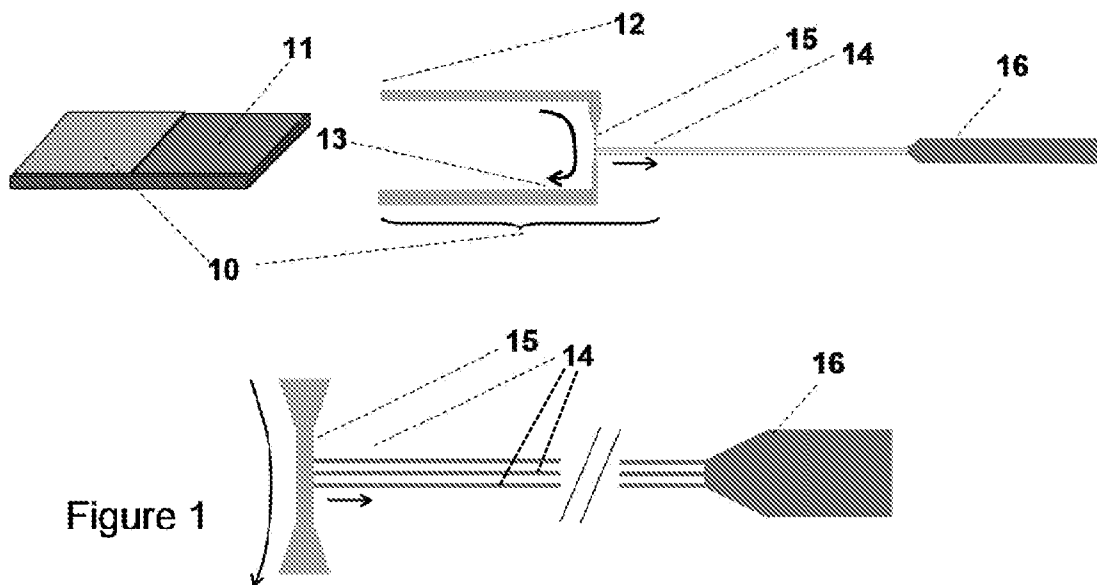

FIG. 1

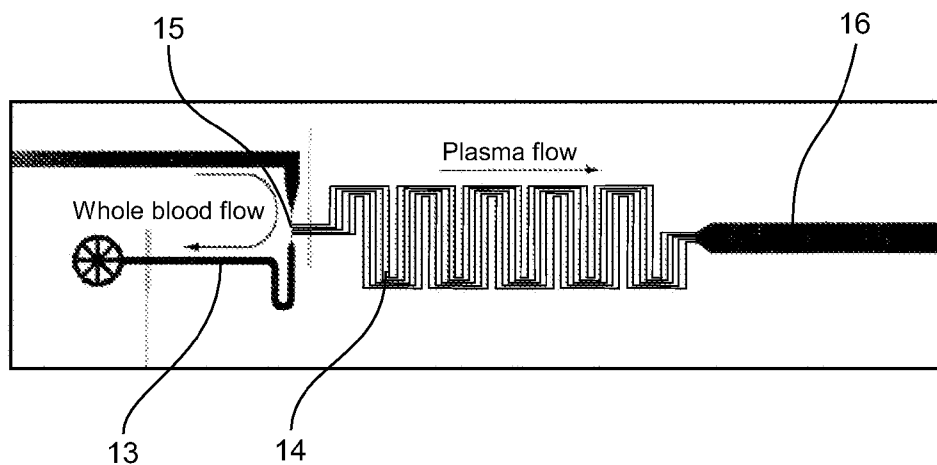

FIG. 2

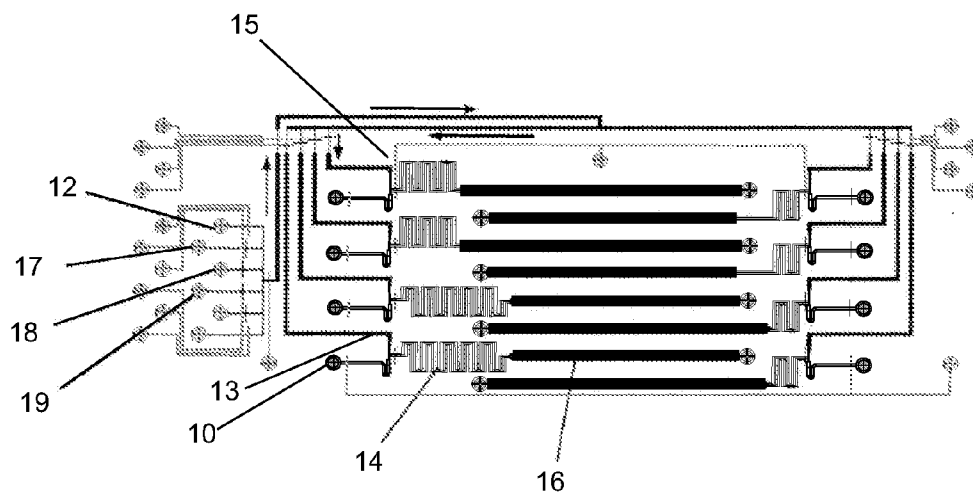

FIG. 3

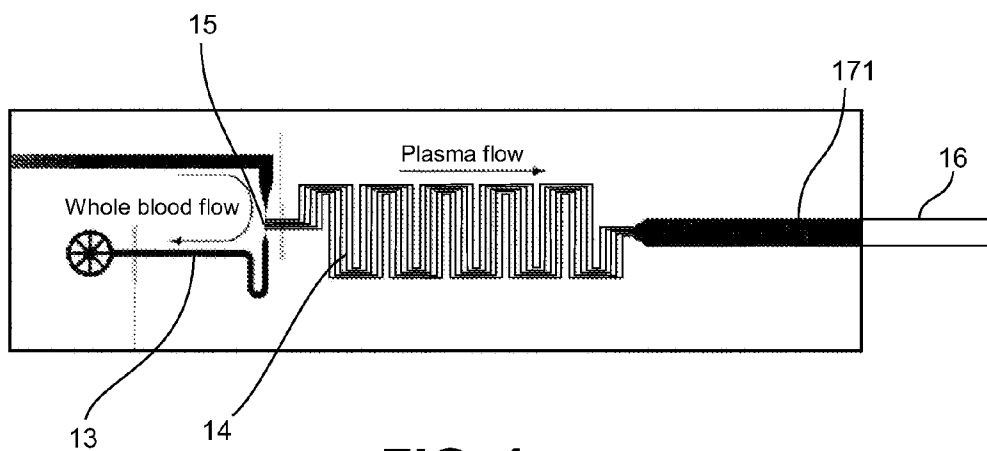

FIG. 4

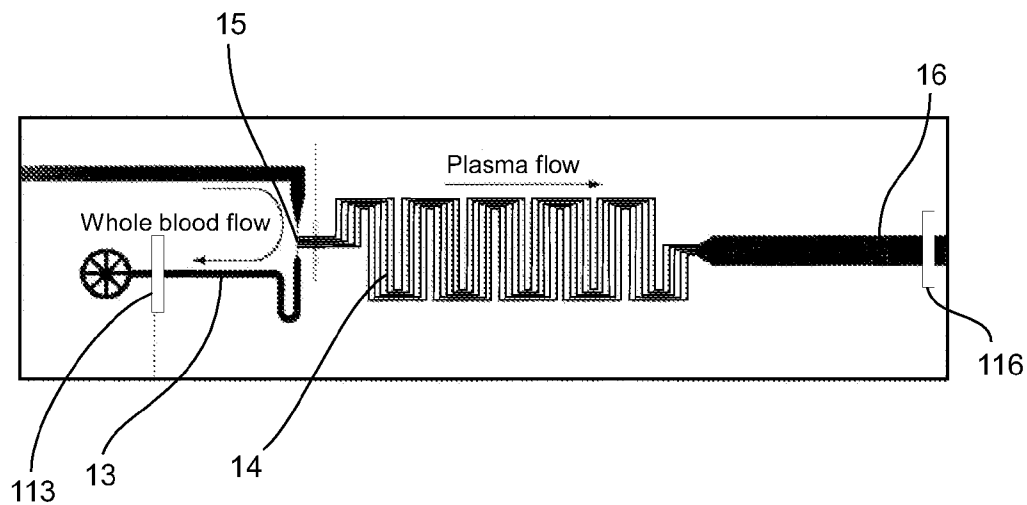

FIG. 5

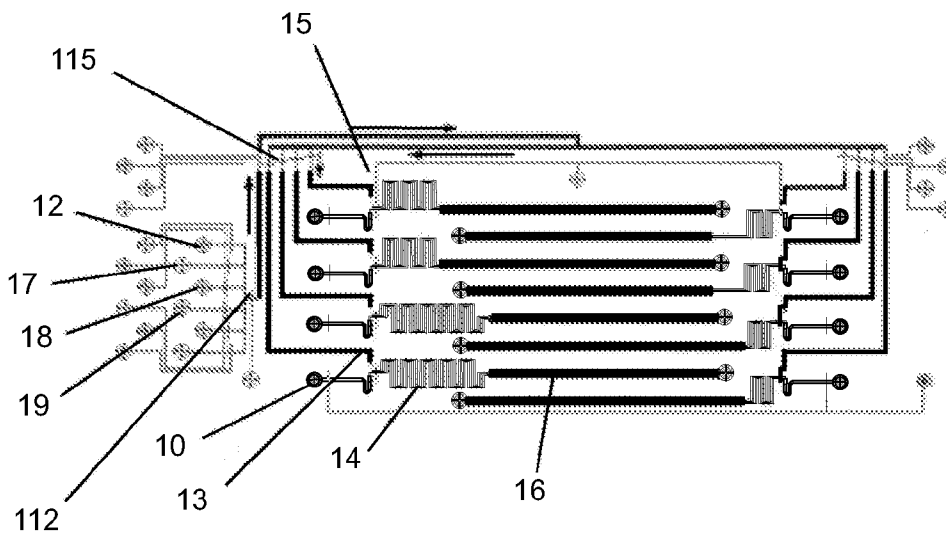

FIG. 6

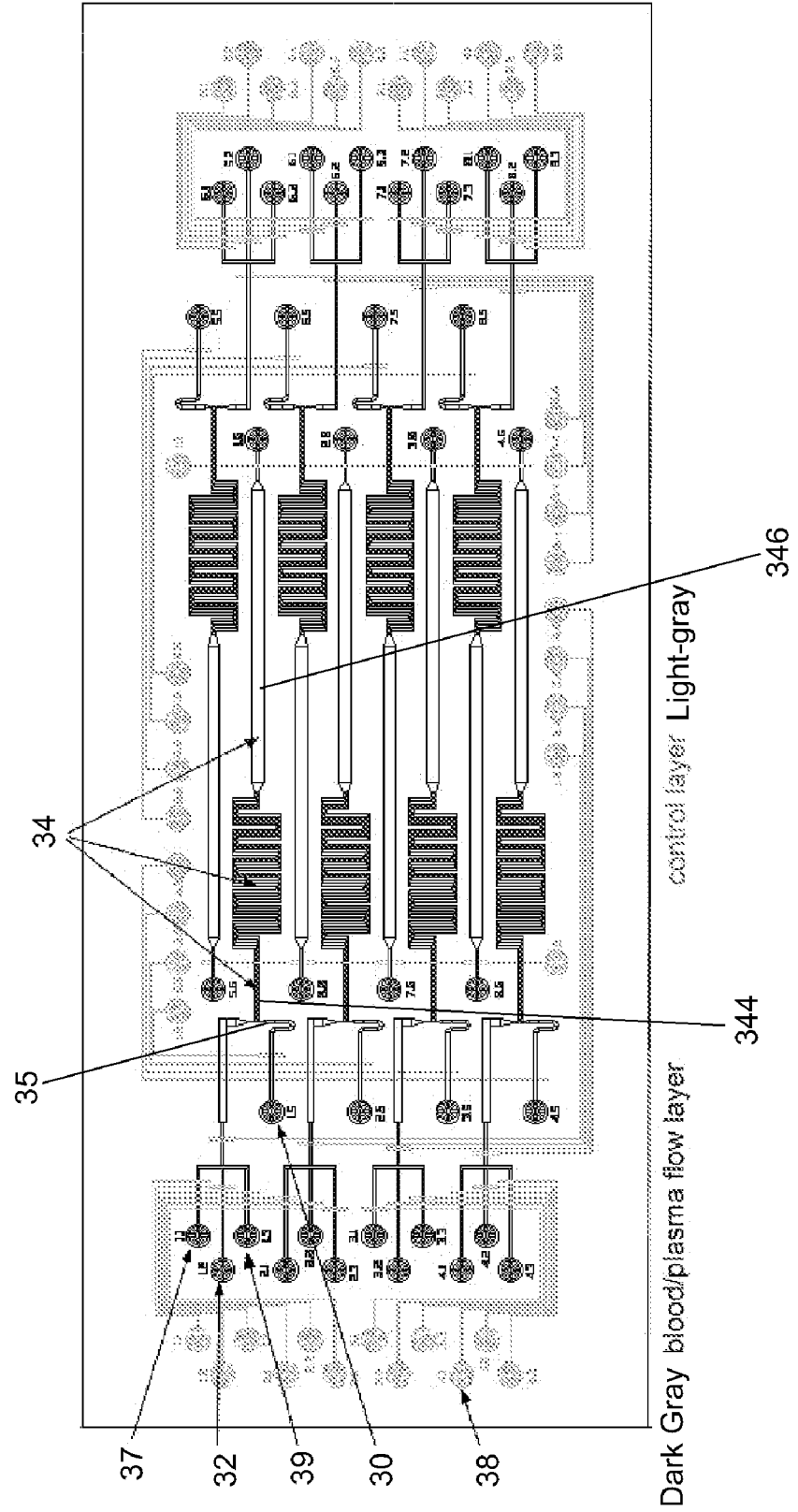

FIG. 7

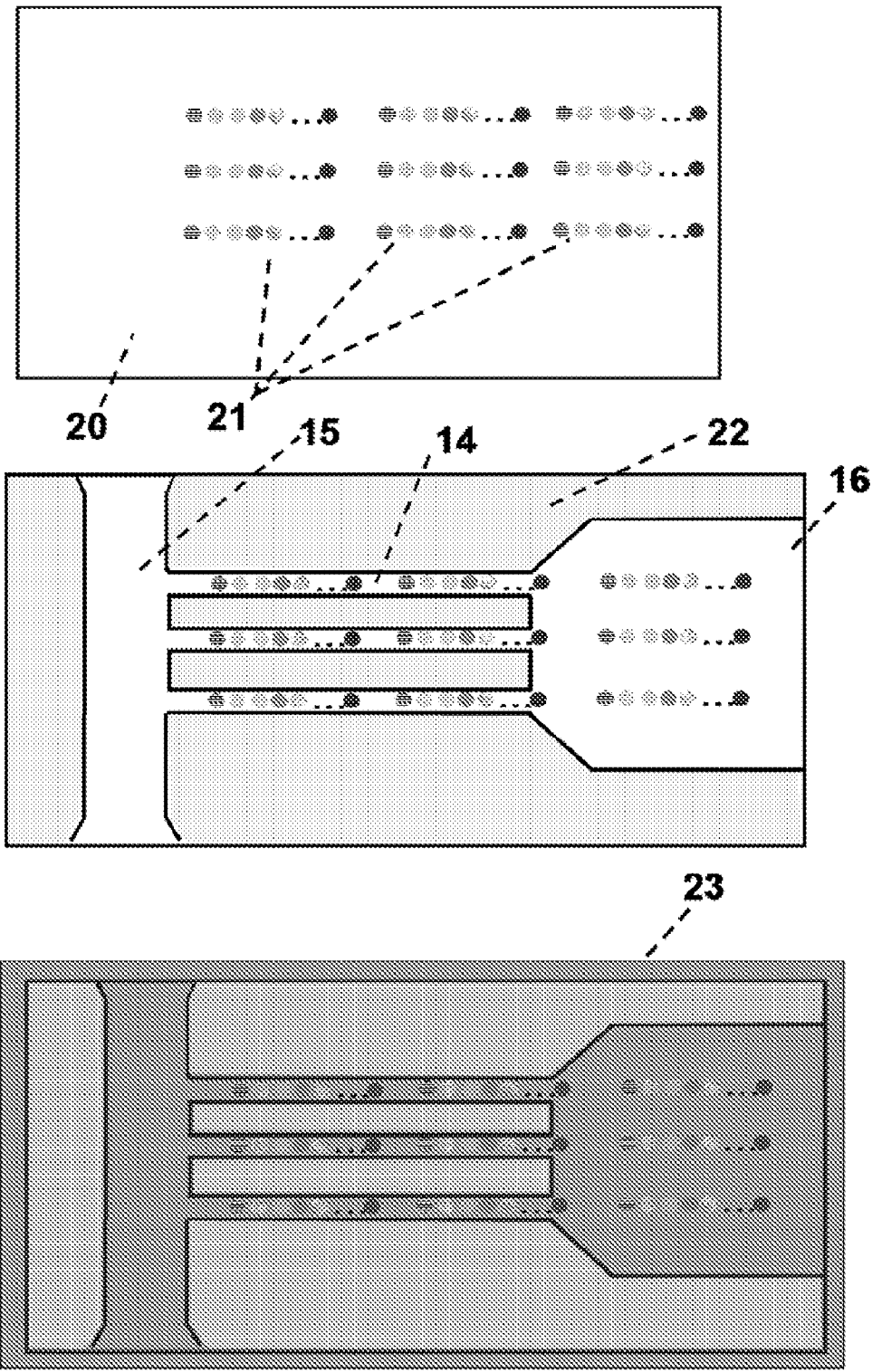

FIG. 8

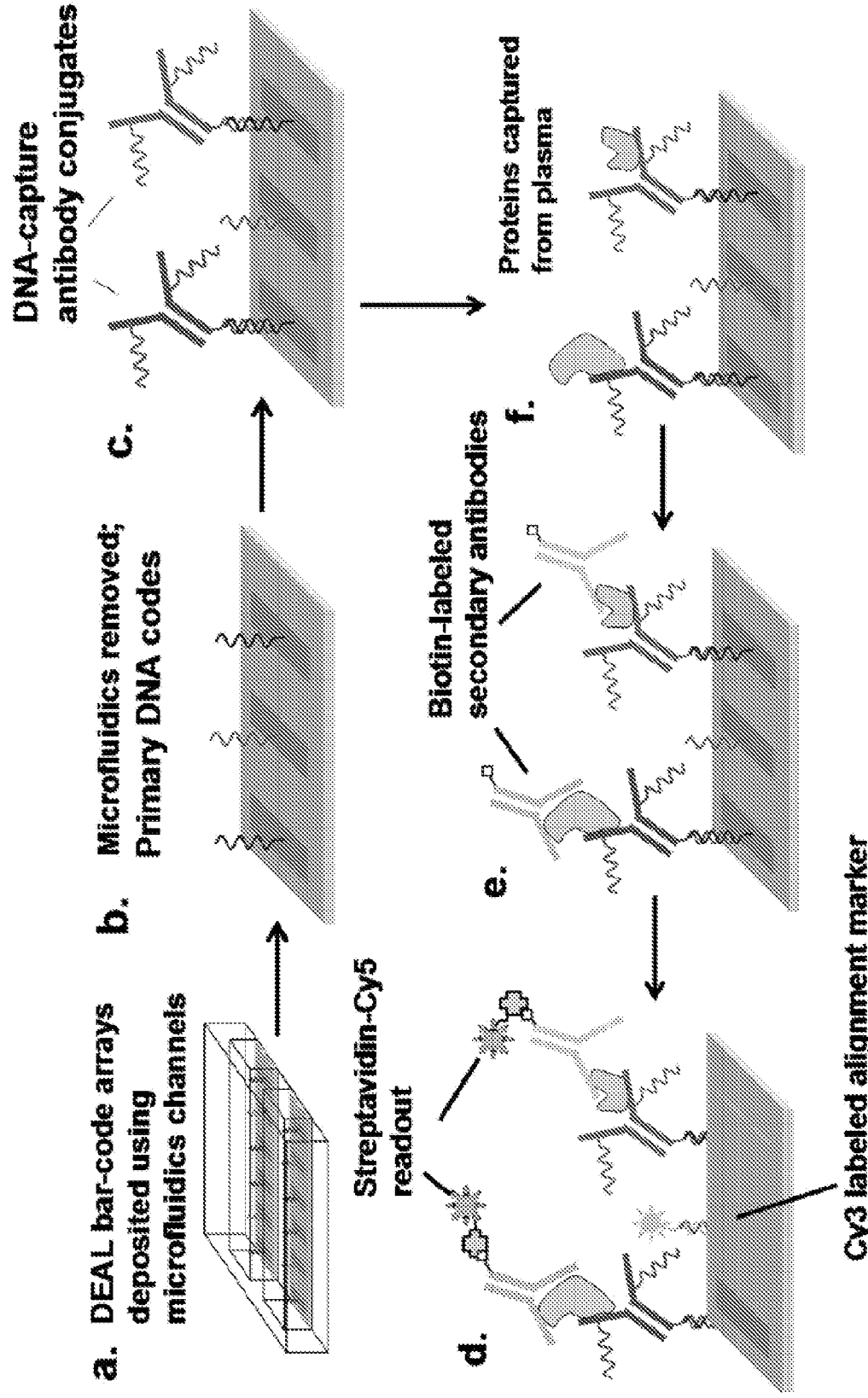

FIG. 9

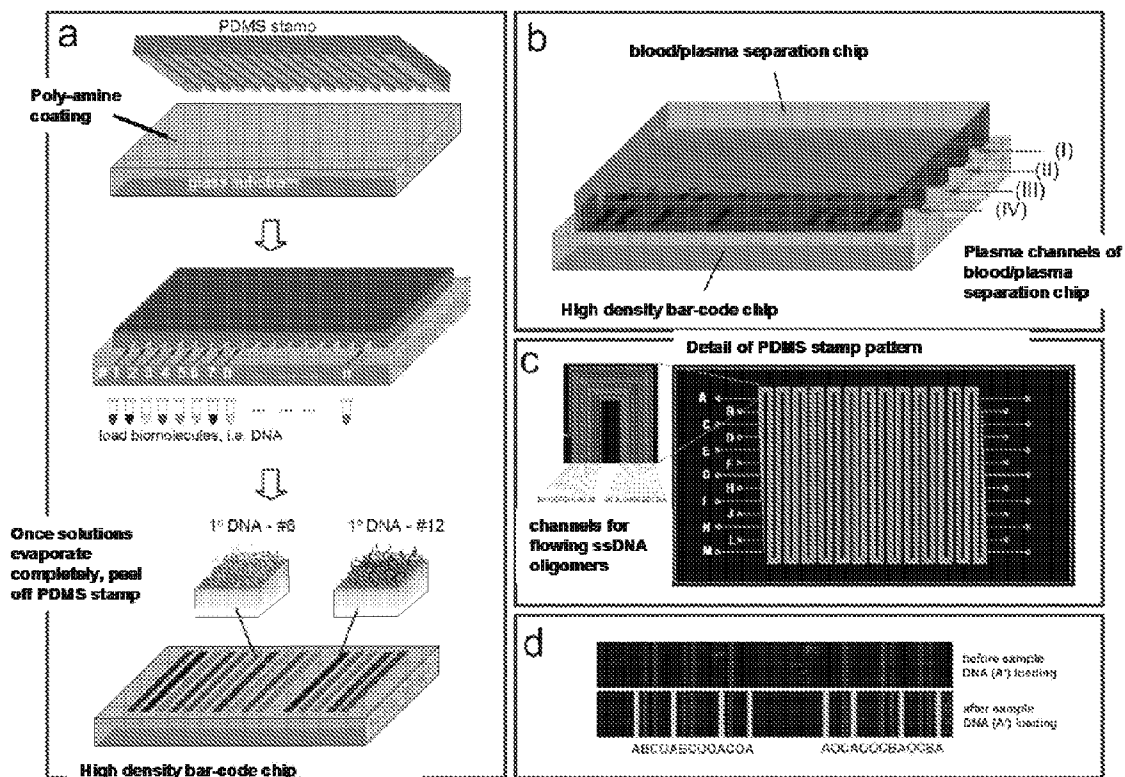

FIG. 10

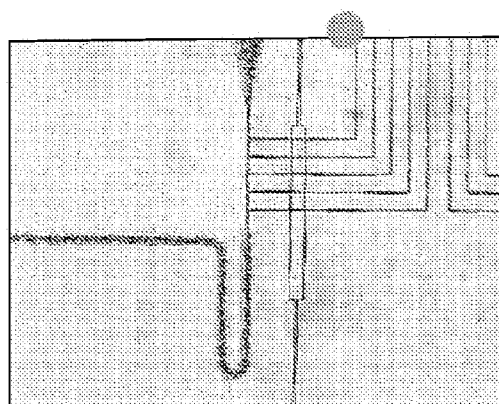

FIG. 11

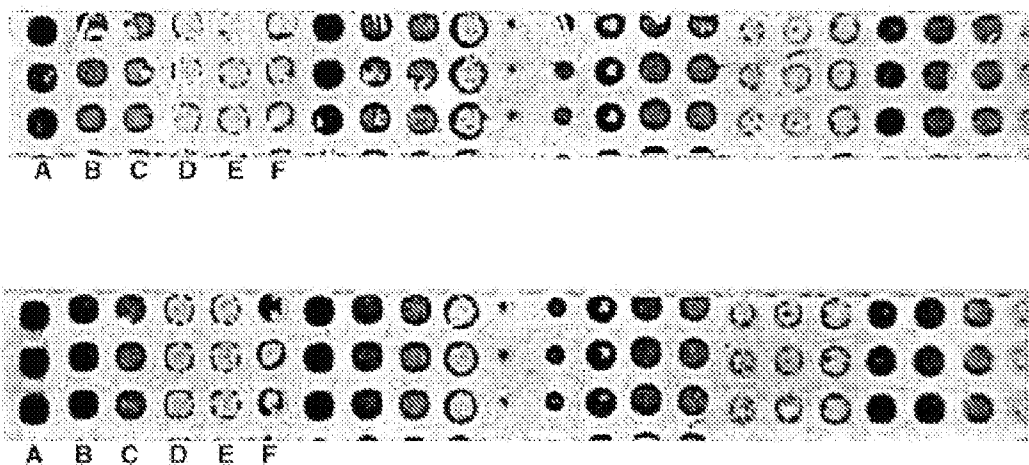

FIG. 12

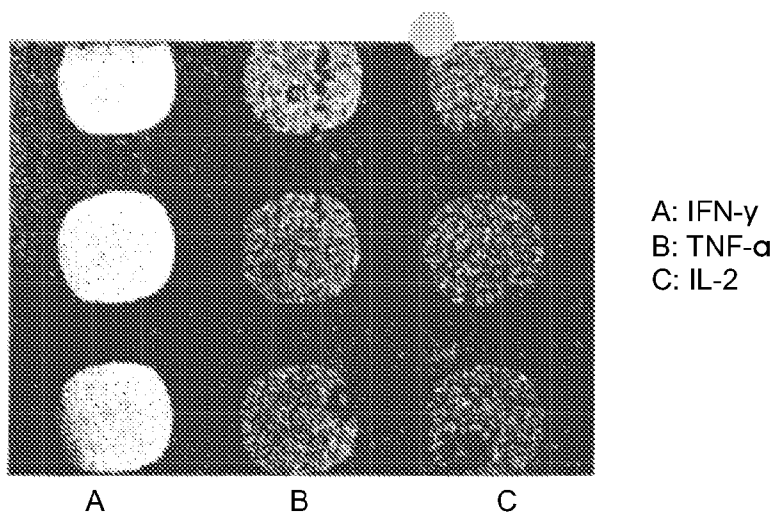
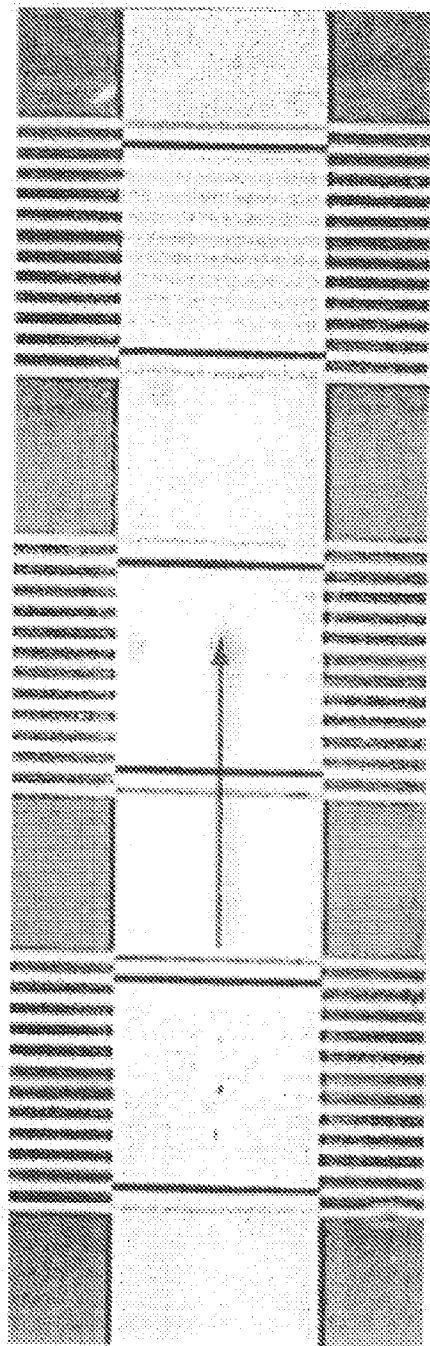
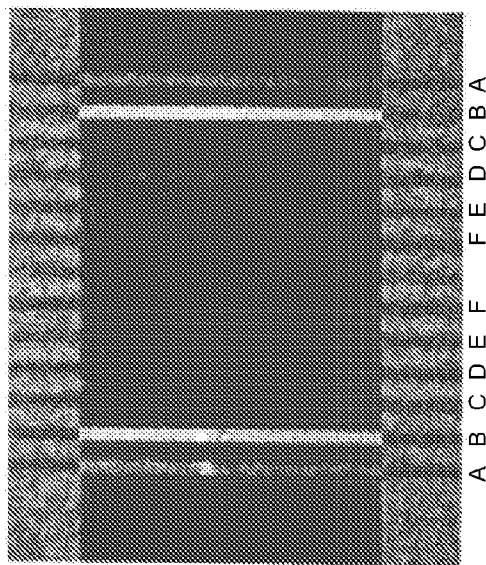

FIG. 13



A: IFN- γ , 500 pM
B: TNF- α , 1nM



A B C D E F F E D C B A

FIG. 14

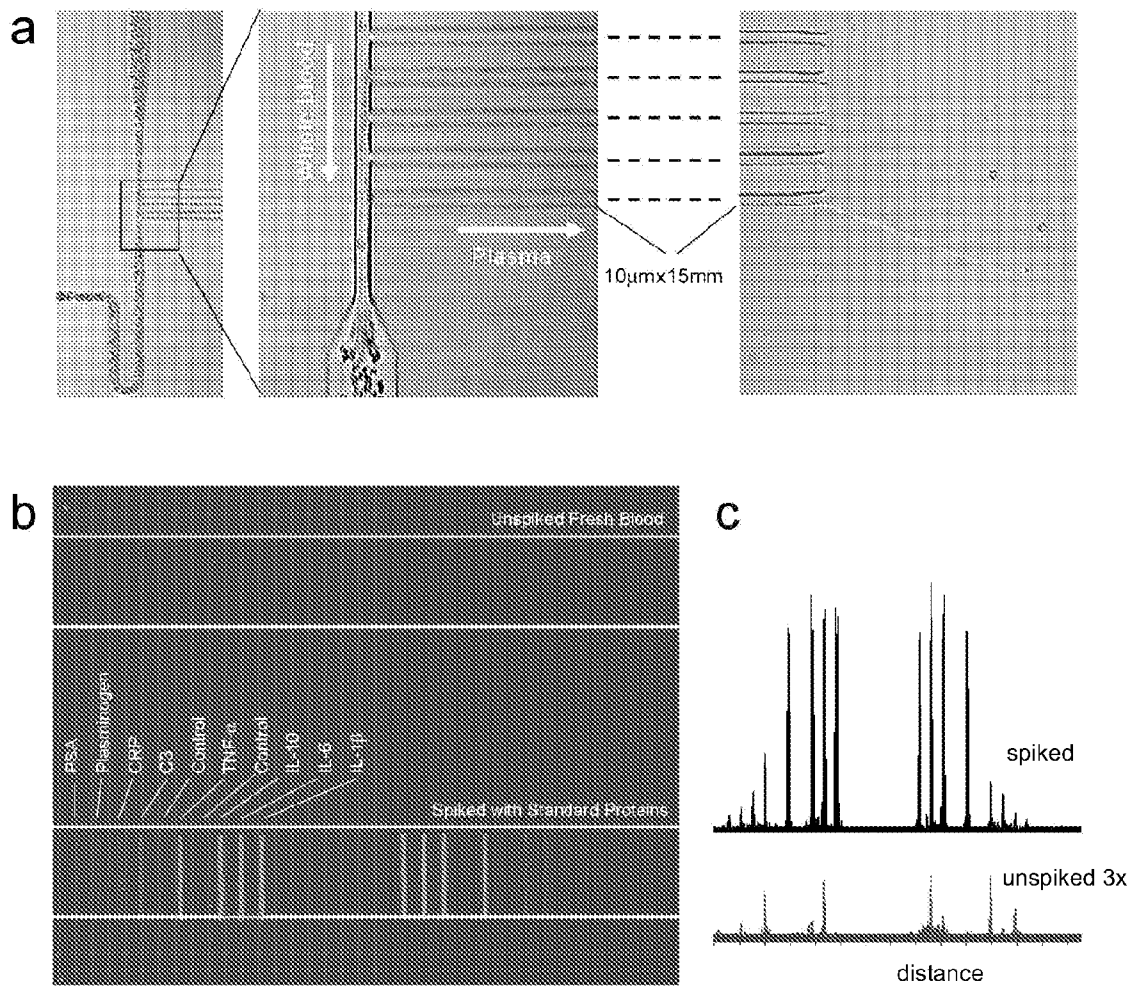

FIG. 15

MICROFLUIDIC DEVICES, METHODS AND SYSTEMS FOR DETECTING TARGET MOLECULES

CROSS REFERENCE TO RELATED APPLICATIONS

[0001] This application claims priority to U.S. Provisional Application entitled "An Integrated Blood Platform for Blood Separation and Protein Detection" Ser. No. 60/959,666, filed on Jul. 16, 2007 Docket No. CIT4943-P, and to U.S. Provisional Application entitled "High-Density Bar-code Array: A Generic Patterning Technique and Biodetection Devices Fabricated Therefrom" Ser. No. 60/998,981 filed on Oct. 15, 2007 Docket No. CIT-5017, the disclosures of both of which are incorporated herein by reference in their entirety. The Application is also related to the U.S. application entitled "Methods and Systems for Detecting and/or Sorting Targets" Ser. No. 11/888,502 filed on Aug. 1, 2007, Docket Number P017-US, and to U.S. application entitled "Arrays, Substrates, Devices, Methods and Systems for Detecting Target Molecules" Serial No. to be assigned filed on Jul. 16, 2008, Docket Number P262-US, the disclosures of both of which are also incorporated herein by reference in their entirety.

STATEMENT OF GOVERNMENT GRANT

[0002] The U.S. Government has certain rights in this disclosure pursuant to Grant No. CAI 19347 awarded by the National Institutes of Health.

TECHNICAL FIELD

[0003] The present disclosure relates to detection of one or more target molecules in a sample. More specifically, it relates to devices, methods and systems for detecting a target molecule in a fluidic component of a fluidic sample.

BACKGROUND

[0004] Detection of target molecules and in particular of biomarkers has been a challenge in the field of biological molecule analysis. In particular, qualitative and quantitative detection of biomarkers is often a critical step in several applications ranging from diagnostics to fundamental biology studies. More particularly, detection of biomarkers that are included in a component of a biological fluid has proven particularly challenging in several applications wherein such detection is desired.

[0005] For example, the diagnosis of several human diseases is performed through detection of a set of biomarkers that can be found in the human plasma proteome (Anderson, N. L. & Anderson, N. G. The human plasma proteome—History, character, and diagnostic prospects. *Molecular & Cellular Proteomics* 1, 845-867 (2002), Lathrop, J. T., Anderson, N. L., Anderson, N. G. & Hammond, D. J. Therapeutic potential of the plasma proteome. *Current Opinion in Molecular Therapeutics* 5, 250-257 (2003)).

[0006] Typically, the detection of such biomarkers involves the extraction of blood, addition of an anti-clotting chemical, and then centrifugation of the blood to separate the cells from the plasma (or serum). Once the plasma (or serum) is obtained, the biomarkers are detected using techniques such as spotting the plasma on 96 well plate.

[0007] Such techniques require a sample amount and a processing time and conditions that can limit the number of biomarkers detectable in a single sample and significantly

impact the reliability of the detection (see Hsieh, S. Y., Chen, R. K., Pan, Y. H. & Lee, H. L. Systematical evaluation of the effects of sample collection procedures on low-molecular-weight serum/plasma proteome profiling. *Proteomics* 6, 3189-3198 (2006)).

[0008] In several applications, wherein reliable detection of a large number of biomarkers is desirable, for example to assess the stage of a disease, stratify patients for therapies, or measure the response of patients to therapy (Gorelik, et al., 2005; Heath & Davis, 2008), the above factors may require processing of multiple samples which can significantly impact the applicability, accuracy and costs of the detection.

[0009] Additionally, in applications wherein the available amount of sample is limited, such as studies in mouse models of human diseases, the above factors can even impair the feasibility of certain assays wherein detection of multiple biomarkers and/or frequent detection of a biomarker or maintenance of the biochemical state of the sample is desired.

SUMMARY

[0010] Provided herein, are devices, methods and systems for detection of a target that allow detection of multiple targets in a fluidic component of a sample, operating on a single sample including a small amount of substance to be tested. In particular, in the devices, methods and systems herein disclosed, separation of the fluidic component from the sample and detection of the targets in the fluidic component are performed in a single device designed to minimize the amount of sample to be processed and the modifications of the samples during processing while maximizing the number of targets detectable with a single measurement.

[0011] According to a first aspect, a microfluidic device is disclosed, for detecting at least one target in a fluidic component of a fluid sample. The microfluidic device comprises: an inlet for introducing the fluid sample in the microfluidic device, a flowing channel in fluidic communication with the inlet, and an assaying channel in fluidic communication with the flowing channel. In the microfluidic device, the flowing channel has a flowing channel resistance, the assaying channel has an assaying channel resistance and the flowing channel resistance and the assaying channel resistance are adapted to control flowing of the fluidic component from the flowing channel to the assaying channel. In the microfluidic device the assaying channel carries at least one capture agent or a component thereof attached to the assaying channel, and the capture agent has a binding affinity for the target molecule. The assaying channel resistance is also adapted to allow binding of the target molecule to the capture agent to form a detectable target capture agent binding complex, so that said binding is controlled by at least one between said binding affinity and said diffusion of said target molecule in the fluidic component.

[0012] According to a second aspect, a method for detecting at least one target in a fluidic component of a fluid sample is disclosed. The method comprises: providing the fluid sample in a flowing microfluidic channel; controlling selective flowing of the fluidic component from the flowing microfluidic channel to an assaying microfluidic channel, the assaying microfluidic channel carrying at least one capture agent or a component thereof, the at least one capture agent attached to the assaying channel, the at least one capture agent having a binding affinity for the target molecule. The method further comprises: contacting the at least one target molecule with the at least one capture agent in the assaying microfluidic

channel for a time and under conditions to allow binding of the at least one target molecule to the at least one capture agent to form a detectable target capture agent binding complex, so that said binding controlled by at least one between said binding affinity and by diffusion of said target molecule in the fluidic component; and detecting the detectable target capture agent binding complex.

[0013] According to a third aspect, a system for detecting at least one target in a fluidic component of a fluid sample is disclosed. The system comprises a microfluidic device herein disclosed wherein the at least one capture agent or component thereof comprises at least one substrate polynucleotide attached to the assaying channel. The system further comprises at least one polynucleotide-encoded protein comprising a protein and an encoding polynucleotide attached to the protein, wherein the protein specifically binds a target and the encoding-polynucleotide specifically binds the substrate polynucleotide.

[0014] According to a fourth aspect, a microfluidic device is disclosed for detecting at least one target in a fluidic component of a fluid sample. The microfluidic device comprises: an inlet for introducing the fluid sample in the microfluidic device, a flowing channel in fluidic communication with the inlet, the flowing channel having a flowing channel resistance, and an assaying channel in fluidic communication with the flowing channel, the assaying channel having an assaying channel resistance. In the microfluidic device the flowing channel resistance and the assaying channel resistance are configured to control flowing of the fluidic component from the flowing channel to the assaying channel, and the assaying channel resistance is further configured to allow attachment of a target on a surface of said assaying channel, the attached target being detectable through labeled molecules specifically binding said target.

[0015] The devices, methods and systems herein disclosed allow detection of multiple targets starting from a single small amount sample in an amount of time significantly reduced with respect to time of execution with prior art techniques. In particular, in certain embodiments, the target detection can be completed in less than 10 minutes, while prior art approaches typically require several hours up to few days.

[0016] The devices, methods and systems herein disclosed also allow detection of a target minimizing the modifications of the sample necessary to allow detection according to prior art methods. The devices, methods and systems herein disclosed also minimize the various chemical and biochemical processes, such as, when the sample is blood, blood clotting, protein degradation by enzymes, etc., that can occur during the few hours to few day time period between sampling and detection when performed with prior art techniques.

[0017] The devices, methods and systems herein disclosed further allow detection of multiple targets in a single measurement thus reducing costs while increasing the accuracy of the process with respect to prior art techniques.

[0018] In general, the devices, methods and systems herein disclosed further allow detection of a target with reduced costs with respect to methods of the art in view of at least one of the following: reducing the sample size; reducing the amount of human effort needed to measure the protein biomarkers; reducing the time required for the measurement; increasing the numbers of measurements for a given amount of effort; increasing the accuracy and reproducibility of such measurements

[0019] The devices, methods and systems herein disclosed are applicable to performance of several assays such as diagnostic assays for cancer, immune system dysfunction, other diseases such as inflammations, of an organ system (e.g. heart, liver, kidney, GI, reproductive, brain), and diseases due to pathogen: bacterial, viral, fungal agent. More particularly, the devices methods and systems herein disclosed can be used for screening and perform early detection of said diseases.

[0020] The devices, methods and systems herein disclosed can also be used to, separate bacterial component from surrounding fluid and detect proteins in the separated bacterial component (e.g. in samples containing bacteria to be studied or removed), in applications such as monitoring sewage or waste water for bacteria or pathogens, and/or monitoring *E. coli* in a reactor (e.g. for recombinant protein production).

[0021] The devices, methods and systems herein disclosed can also be used for research purposes, for example to separate the cells in a cell culture (cancer cell lines/PBMCs, etc) from their surrounding fluid and assay the separated surrounding fluid.

[0022] The details of one or more embodiments of the disclosure are set forth in the accompanying drawings and the description below. Other features, objects, and advantages will be apparent from the description and drawings, and from the claims.

BRIEF DESCRIPTION OF THE DRAWINGS

[0023] The accompanying drawings, which are incorporated into and constitute a part of this specification, illustrate one or more embodiments of the present disclosure and, together with the detailed description, serve to explain the principles and implementations of the disclosure.

[0024] FIG. 1 shows a schematic illustration of a device according to an embodiment herein described.

[0025] FIG. 2 shows a schematic illustration of the fluid separation region of the device of FIG. 1, according to an embodiment herein disclosed.

[0026] FIG. 3 shows a schematic illustration of a microfluidic device according to an embodiment herein disclosed.

[0027] FIG. 4 shows a schematic illustration of a microfluidic device according to an embodiment herein disclosed.

[0028] FIG. 5 shows a schematic illustration of a microfluidic device according to an embodiment herein disclosed.

[0029] FIG. 6 shows a schematic illustration of a microfluidic device according to an embodiment herein disclosed.

[0030] FIG. 7 shows a schematic illustration of a microfluidic device according to an embodiment herein disclosed. The control layer is shown in light gray. The sample layer is shown in dark gray.

[0031] FIG. 8 shows an exemplary schematic illustration of various phases of a process to manufacture a device herein disclosed.

[0032] FIG. 9 shows a schematic exemplary schematic illustration of a process to manufacture and use a device integrated with DEAL technology according to an embodiment herein disclosed.

[0033] FIG. 10 shows a schematic exemplary schematic illustration of a process to manufacture and use a device according to an embodiment herein disclosed.

[0034] FIG. 11 shows a photograph of a device according to the disclosure, during separation of an exemplary fluid formed by diluted sheep blood.

[0035] FIG. 12 shows a bright-field image of two assay lanes performed with the methods and devices herein disclosed.

[0036] FIG. 13 shows a dark field image of the assay illustrated in FIG. 9.

[0037] FIG. 14 shows an image of an assay channel region of a device according to an embodiment herein disclosed (top) and an assay performed on the device according to an embodiment herein disclosed.

[0038] FIG. 15 shows an exemplary measurement of a panel of blood biomarkers from a finger-prick of whole blood. Panel (a) shows optical micrographs of a device herein disclosed while performing separation of plasma from fresh whole blood. Panel (b) shows a fluorescence image of blood barcodes in two adjacent microchannels of a device herein disclosed, on which both the unspiked and spiked fresh whole blood collected from a healthy volunteer were separately assayed. The bars are all 20 μ m in width. Panel (c) shows fluorescence line profiles of the barcodes for both unspiked and spiked whole blood samples assayed as illustrated in Panel (b). The distance corresponds to the full length shown in Panel (b).

DETAILED DESCRIPTION

[0039] Devices, methods and systems for detecting target molecules in a sample are herein disclosed.

[0040] The term “detect” or “detection” as used herein indicates the determination of the existence, presence or fact of a target or signal in a limited portion of space, including but not limited to a sample, a reaction mixture, a molecular complex and a substrate. A detection is “quantitative” when it refers, relates to, or involves the measurement of quantity or amount of the target or signal (also referred as quantitation), which includes but is not limited to any analysis designed to determine the amounts or proportions of the target or signal. A detection is “qualitative” when it refers, relates to, or involves identification of a quality or kind of the target or signal in terms of relative abundance to another target or signal, which is not quantified.

[0041] The term “target” or “target molecule” as used herein indicates an analyte of interest. The term “analyte” refers to a substance, compound or component whose presence or absence in a sample has to be detected. Analytes include but are not limited to biomolecules and in particular biomarkers. The term “biomolecule” as used herein indicates a substance compound or component associated to a biological environment including but not limited to sugars, amino acids, peptides proteins, oligonucleotides, polynucleotides, polypeptides, organic molecules, haptens, epitopes, biological cells, parts of biological cells, vitamins, hormones and the like. The term “biomarker” indicates a biomolecule that is associated with a specific state of a biological environment including but not limited to a phase of cellular cycle, health and disease state. The presence, absence, reduction, upregulation of the biomarker is associated with and is indicative of a particular state.

[0042] The term “sample” as used herein indicates a limited quantity of something that is indicative of a larger quantity of that something, including but not limited to fluids from a biological environment, specimen, cultures, tissues, commercial recombinant proteins, synthetic compounds or portions thereof. Additionally exemplary samples include bodily fluids such as sputum, CSF, sweat, urine, semen, biopsy speci-

mens, pap smear samples or any other sample obtained from a human or an animal being that contains a liquid component and a cell component.

[0043] A further description of the devices methods and systems of the present disclosure is provided with reference to applications wherein the sample is blood, the fluidic component is plasma and the targets are biomarkers. A person skilled in the art will appreciate the applicability of the features described in detail for blood samples and biomarkers for other biologic, organic and inorganic samples and targets. The devices methods and systems herein disclosed although designed to separate plasma from blood could be used to obtain particle-free fluid from any medium containing micron sized particles and detect molecules using capture agents of any kind.

[0044] In some embodiments, the present disclosure relates to a device that combines plasma separation from whole blood with detection of multiple biomarkers from the plasma.

[0045] An exemplary device of the disclosure is shown in FIGS. 1-6. Microfluidic flow channels are patterned on a chip, designed so that on one region of the chip (10) plasma is separated from whole blood, and in a second region of the chip (11), proteins or other analytes are measured from the separated plasma. In the chip of FIG. 1, whole blood is introduced at a microfluidic channel inlet (12), whole blood minus a fraction of the plasma is removed from the chip via a microfluidic channel (13), or stored in a waste reservoir on chip (not shown). In the depiction of FIG. 1, channel (13) is located in region (10). The reservoir can be located at the end of channel (13).

[0046] Region (10) also includes a relatively wide or low-flow-resistance channel (15) fluidically connected with one or more relatively narrow, high-flow-resistance channels (14), which in turn are fluidically connected with channels (16). Channels (14) and (16) are included in region (11) of the chip depicted in FIG. 1. The relative flow-resistances of channels (15, 14, 16) may be varied by design.

[0047] In the device of FIGS. 1-6, plasma separation from whole blood is performed by controlling the plasma flow from the wider microfluidic channels (15) into the thin microfluidics channels (14) using the Zweifach-Fung effect which is well known in the art (Fung, Y. C. Stochastic flow in capillary blood vessels. *Microvasc. Res.* 5, 34-38 (1973); Svanes, K. & Zweifach, B. W. Variations in small blood vessel hematocrits produced in hypothermic rates by micro-occlusion. *Microvascular Research* 1, 210-220 (1968); Yang, S., Undar, A. & Zahn, J. D. A microfluidic device for continuous, real time blood plasma separation. *Lab on a Chip* 6, 871-880 (2006)).

[0048] In the device of FIGS. 1-6, to achieve the Zweifach-Fung effect, whole blood is flowed through channel (15) in fluidic communication with channels (14). If the flow-resistances are the same, then whole blood will flow through both sets of channels. If the flow-resistance of the narrow channels (14) is greater than the resistance of channel (15), plasma will be conveyed from channel (15) to channel (14).

[0049] In some embodiments, the flow rate ratio between flowing channel (15) and assaying channel (14) can be as low as about 4:1. In other embodiments, wherein the flow rates ratio between the flow rate of channel (14) and the flow rate of channel (15) is at least, or also greater than about 20:1, the flow of plasma from channel (15) into channel (14) is maximized regardless of the inlet hematocrit. Also at a flow rate ratio of about 20:1 a good separation efficiency is observed

(less than 20 cells detectable in channels (14) and (16) upon visual inspection). In some embodiments, as the ratio between the flow rate of channel (14) and the flow rate of channel (15) is increased over the about 20:1 ratio, the separation efficiency is also improved but the yield of plasma (and accordingly input fluid to be assayed) is correspondingly decreased.

[0050] In some embodiments, the ratio between the flow rate of channel (14) and the flow rate of channel (15) is increased over the about 20:1 ratio to values that allow maintaining a separation yield above 5%. In particular, in some embodiments, the flow ratio between the flowing channel (15) and the assaying channel (14) can be over about 100:1, from about 60:1 to about 100:1, from about 35:1 to about 60:1, or from 20:1 to 35:1.

[0051] More particularly, in certain embodiments wherein a maximized separation efficiency and long assay time are desired or acceptable, a flow rate ratio between flowing channel (15) and assaying channel (14) over about 100:1 could be selected. In other embodiments wherein optimized separation yield and assaying time are desired, a flow rate ratio between flowing channel (15) and assaying channel (14) of from about 35:1 to about 60:1 can be selected.

[0052] A desired flow rate ratio for a sample and an experimental design of choice can be identified based on the radius of particles in the samples that, according to the experimental design of choice have to be separated from the fluidic component that is conveyed in the assaying channels. In particular, the flow rate ratio is inversely proportional to the radius of the particles to be separated as indicated in Appendix A of the present application, herein incorporated by reference in its entirety. The term "particle" as used herein identifies a small portion of matter that behaves as a whole unit in terms of its fluidic transport and properties, which includes cells, such as red blood cells, or aggregates thereof but can also include other particulate matter of organic or inorganic nature and aggregates thereof.

[0053] In the device of FIGS. 1-6, channel (14) is further fluidically connected to an assaying channel (16). In the embodiments, exemplified in FIGS. 1-6, channel (16) is an assaying channel that hosts one assaying region wherein an assay for target detection is performed.

[0054] The resistances of all the channels can be adjusted to achieve the desired flow rate ratio between channels (14) and (15), by adjusting the channel dimensions of various channels in, taking into account that plasma channels (14) will have a greater flow resistance if they are narrower and/or longer. Alternatively, channel (15) can be adjusted to be wider and/or shorter to decrease its flow resistance (which would also help to increase the resistance ratio between the two channels). Furthermore, in some embodiments, channel (16) can have a width at least an order of magnitude (10x) greater than the width of plasma channel (14) to minimize the impact of channel (16) on the resistance and separation efficiency. However, width and length of channel (16), as well as channels (15) and (14) and the related flow resistance can be varied according to the desired chip configuration using the methods and programs herein disclosed.

[0055] In particular, appropriate flow rate ratio for a specific chip can be identified by a skilled person taking into account that in a pressure driven flow, the flow rate Q (m^3/s) within a microchannel is defined by $Q = \Delta P/R$ where ΔP is the pressure difference for driving the flow between an inlet and an outlet (Pa), and R is the channel resistance (Pa s m^{-3}).

[0056] Appropriate dimensions of the channels of a microfluidic device to obtain the desired flow rate ratio can be identified by a skilled person taking into account the relationship between channel resistance and channel dimensions. For example for a rectangular microchannel with a low aspect ratio ($w \sim h$) the following equation can be considered:

$$R = \frac{12 \mu L}{wh^3} \left[1 - \frac{h}{w} \left(\frac{192}{\pi^5} \sum_{n=1,3,5}^{\infty} \frac{1}{n^5} \tanh\left(\frac{n\pi w}{2h}\right) \right) \right]^{-1}$$

wherein R is the channel resistance, w is the width of the channel, h is the height of the channel, L is the length of the channel, and μ is the viscosity of the fluid. This equation can be used to determine the resistances of all channels and to control said resistance to optimize the plasma separation according to the experimental design.

[0057] A software program was created by the Applicants to allow a user to input the length, width, and height for each channel and the viscosity of the fluid, to obtain a corresponding resistance of the channel.

[0058] According to the program, dimensions for all channels within certain ranges and the desired input pressure (generally 5-10 psi) are initially input by a user. For example, for plasma separation the input channel depth can be about 10-20 μm , the width and length of channel (15) can be in the range of 15-35 μm , and in the range of 100-500 μm respectively, the width of channel (13) can be between 60 and 200 μm , and the length of the plasma channels (14) and (16) can be between 5 mm and 25 mm (see additional indications in Appendix A).

[0059] The program then computes resistances of all channels based on the input dimensions. The program inserts these values into a resistance matrix, obtained as indicated in Appendix A to the present application, which shows the system of equations and associated matrices. The inverse of the resistance matrix is then multiplied by a pressure matrix (see Appendix A) to obtain the flow rates matrix which contains the flow rate for each channel. The program can also sum all the above plasma channel flow rates and divide over the channel (15) output flow rate to determine the percentage of the blood that is separated as plasma (this gives the yield). The program then outputs the resistances and flow rates for all the channels, the flow ratios, and a percentage plasma yield.

[0060] Suitability of the output parameters for an experimental design of choice can be identified by a skilled person upon reading of the present disclosure. If the parameters do not suit the experimental purpose, they can be adjusted accordingly.

[0061] For example, for blood/plasma separation if the flow rate ratio is below 20:1, and a good separation of plasma from whole blood is desired as well as a high yield of plasma and short assay time, new channel dimensions can be input into the program that are expected to increase the flow ratio (for example, lengthening the plasma channel, increasing the width of channel (13), etc). The process can then be repeated iteratively until the greatest flow rate ratio possible while still maintaining greater than 5% yield and flow rates greater than 100 $\mu\text{m}/\text{sec}$ in channel (16), are achieved. The input dimensions that provide the flow rate ratio compatible with the desired design (also in view of the desired setting for target detection in the assaying channels—see below) can be used

for the related device. Reference is also made to the Appendix A to the present application incorporated herein by reference in its entirety.

[0062] In some embodiments, the width of the plasma channels can be held constant (e.g. at 10 μm in accordance with the Yang, Sung et al. Blood Plasma Separation in Microfluidic Channels using Flow Rate Control. *ASAIO Journal* 2005; 51: 585-590) and while the length of the plasma channels (14) and/or the width of region (13) are varied.

[0063] In some embodiments, the length of the plasma channels (14) and the width of channels (13) were increased to obtain a desired flow ratio. In those embodiments, the orientation of channels (14) with respect to channels (15) can be varied according to the desired chip configuration, even if in some embodiments herein illustrated the channels are perpendicular.

[0064] In some embodiments the program can be operated with a software such as Matlab, that already contains a built in matrix multiplication function.

[0065] In certain embodiments, the software program can also use the above relation $Q=\Delta P/R$ and the conservation of mass transport law to determine the volume flow rate in each channel based on the resistance calculated for each channel. Because of the conservation of mass transport, the flow rates in the various channels are interdependent. In other words, if the flow entering channel 15 is defined as Q_{15} in, the flow entering the first plasma channel of region 14 is $Q_{14.1}$, and the flow in region 15 immediately below the first plasma channel as $Q_{15.1}$, then $Q_{15in}=Q_{14.1}+Q_{15.1}$. Next, $Q_{15.1}=Q_{14.2}+Q_{15.2}$, and so forth for all subsequent plasma channels.

[0066] Also the software program herein described also allows devising a system of equations describing the pressure drop in each channel as a function of known resistances and unknown flow rates can be written in accordance with the present disclosure. In the end, the system of n equations and n unknowns can be solved using matrix algebra in which there is a flow matrix, a pressure matrix, and a resistance matrix, such that again $Q=\Delta P/R$. These matrices of equations once introduced in a program such as Matlab can easily be solved, allowing identification of the flow rates in each channel given an input pressure. The program can then output the ratios of the flows, for example, $Q_{14.1}:Q_{15.1}$, $Q_{14.2}:Q_{15.2}$, etc.

[0067] A person skilled in the art, upon reading of the present disclosure, will be able to calculate the appropriate resistances of all channels for the various embodiments based on the channel dimensions and to determine the volume flow rates of fluid through each channel at a given inlet pressure, using for example software programs such as Matlab program.

[0068] In the device of FIGS. 1-6, separation of plasma from whole blood is performed through controlled flow of the plasma from flowing channel (15) flowing to assaying channels (14) and (16).

[0069] The wording "flowing channel" as used herein indicates the portion of the device wherein the separation of one or more fluidic components of a sample from the sample is performed. For example, in embodiments herein disclosed it identifies channel (15) wherein the blood is flowed and from which the plasma component is conveyed into assaying channels (14) and (16)

[0070] The wording "assaying channel" as used herein indicates the portion of the device wherein the detection of the target is performed. For example, in embodiments herein

disclosed assaying channels (14) and (16) are configured to receive cell-free plasma that can be assayed by underlying capture agents.

[0071] In particular, in the device of FIGS. 1-6, channels (14) and (16) can carry capture agents attached on the surface of the channel for detection of the target in the plasma fraction to be tested as also illustrated in the schematic illustration of FIG. 8 (see below) wherein capture agent spots (21) are indicated.

[0072] The wording "capture agents" as used herein indicate a molecule capable of specific binding with a predetermined target to form a detectable capture agent target complex. Exemplary capture agents include but are not limited to polynucleotides and proteins, and in particular antibodies.

[0073] The term "polynucleotide" as used herein indicates an organic polymer composed of two or more monomers including nucleotides, nucleosides or analogs thereof. The term "nucleotide" refers to any of several compounds that consist of a ribose or deoxyribose sugar, joined to a purine or pyrimidine base and to a phosphate group and that are the basic structural units of nucleic acids. The term "nucleoside" refers to a compound (as guanosine or adenosine) that consists of a purine or pyrimidine base combined with deoxyribose or ribose and is found especially in nucleic acids. The term "nucleotide analog" or "nucleoside analog" refers respectively to a nucleotide or nucleoside in which one or more individual atoms have been replaced with a different atom or with a different functional group. Accordingly, the term polynucleotide includes nucleic acids of any length DNA RNA analogs and fragments thereof. A polynucleotide of three or more nucleotides is also called nucleotide oligomers or oligonucleotide.

[0074] The term "polypeptide" as used herein indicates an organic polymer composed of two or more amino acid monomers and/or analogs thereof. The term "polypeptide" includes amino acid polymers of any length including full length proteins and peptides, as well as analogs and fragments thereof. A polypeptide of three or more amino acids is also called a protein oligomer or oligopeptide. As used herein the term "amino acid", "amino acidic monomer", or "amino acid residue" refers to any of the twenty naturally occurring amino acids including synthetic amino acids with unnatural side chains and including both D and L optical isomers. The term "amino acid analog" refers to an amino acid in which one or more individual atoms have been replaced, either with a different atom, isotope, or with a different functional group but is otherwise identical to its natural amino acid analog.

[0075] The term "protein" as used herein indicates a polypeptide with a particular secondary and tertiary structure that can participate in, but not limited to, interactions with other biomolecules including other proteins, DNA, RNA, lipids, metabolites, hormones, chemokines, and small molecules.

[0076] The term "antibody" as used herein refers to a protein that is produced by activated B cells after stimulation by an antigen and binds specifically to the antigen promoting an immune response in biological systems and that typically consists of four subunits including two heavy chains and two light chains. The term antibody includes natural and synthetic antibodies, including but not limited to monoclonal antibodies, polyclonal antibodies or fragments thereof. Exemplary antibodies include IgA, IgD, IgG1, IgG2, IgG3, IgM and the like. Exemplary fragments include Fab Fv, Fab' F(ab')₂ and the like. A monoclonal antibody is an antibody that specifi-

cally binds to and is thereby defined as complementary to a single particular spatial and polar organization of another biomolecule which is termed an "epitope". A polyclonal antibody refers to a mixture of monoclonal antibodies with each monoclonal antibody binding to a different antigenic epitope. Antibodies can be prepared by techniques that are well known in the art, such as immunization of a host and collection of sera (polyclonal) or by preparing continuous hybridoma cell lines and collecting the secreted protein (monoclonal).

[0077] The wording "specific" "specifically" or "specificity" as used herein with reference to the binding of a molecule to another refers to the recognition, contact and formation of a stable complex between the molecule and the another, together with substantially less to no recognition, contact and formation of a stable complex between each of the molecule and the another with other molecules. Exemplary specific bindings are antibody-antigen interaction, cellular receptor-ligand interactions, polynucleotide hybridization, enzyme substrate interactions etc. The term "specific" as used herein with reference to a molecular component of a complex, refers to the unique association of that component to the specific complex which the component is part of. The term "specific" as used herein with reference to a sequence of a polynucleotide refers to the unique association of the sequence with a single polynucleotide which is the complementary sequence.

[0078] The term "attach" or "attached" as used herein, refers to connecting or uniting by a bond, link, force or tie in order to keep two or more components together, which encompasses either direct or indirect attachment such that for example where a first molecule is directly bound to a second molecule or material, and the embodiments wherein one or more intermediate molecules are disposed between the first molecule and the second molecule or material.

[0079] In some embodiments, the same area or different areas of channels (14) and (16) can be coated with different capture agents each bindingly distinguishable from another. In some embodiments, the same area or different areas of channels (14) and (16) can be coated with different capture agents each positionally distinguishable from another

[0080] The wording "bindingly distinguishable" as used herein with reference to molecules, indicates molecules that are distinguishable based on their ability to specifically bind to, and are thereby defined as complementary to a specific molecule. Accordingly, a first molecule is bindingly distinguishable from a second molecule if the first molecule specifically binds and is thereby defined as complementary to a third molecule and the second molecule specifically binds and is thereby defined as complementary to a fourth molecule, with the fourth molecule distinct from the third molecule.

[0081] The wording "positionally distinguishable" as used herein refers to with reference to molecules, indicates molecules that are distinguishable based on the point or area occupied by the molecules. Accordingly, positionally distinguishable capture agents are substrate polynucleotide that occupy different points or areas on the assaying channel and are thereby positionally distinguishable. In embodiments, wherein bindingly and possibly also positionally distinguishable capture agents are used detection of a plurality of biomarkers can be performed in a single channel or in a portion thereof.

[0082] In other embodiments, channel (14) and (16) of the device of FIGS. 1 to 6, does not include capture agents in all or part of the assaying channels. In those embodiments, blood

can be flowed through flowing channel (15) and after separation of the plasma in channel (14), the analytes and in particular the biomolecules are attached and in particular adsorbed to channel (14) and/or (16) surface.

[0083] In some embodiments, detection of the attached analyte and/or capture agent target complex is performed by providing a labeled molecule, which includes any molecule that can specifically bind a capture agent target complex to be detected (e.g. an antibody, aptamers, peptides etc) and a label that provides a labeling signal, the label compound attached to the molecule. The labeled molecule is contacted with the attached analyte and/or capture agent target complex and the labeling signal from the label compound bound to attached analyte and/or the capture agent-target complex on the substrate can then be detected, according to procedure identifiable by a skilled upon reading of the present disclosure and, in particular, of the Examples section.

[0084] The terms "label" and "labeled molecule" as used herein as a component of a complex or molecule refer to a molecule capable of detection, including but not limited to radioactive isotopes, fluorophores, chemiluminescent dyes, chromophores, enzymes, enzyme substrates, enzyme cofactors, enzyme inhibitors, dyes, metal ions, nanoparticles, metal sols, ligands (such as biotin, avidin, streptavidin or haptens) and the like. The term "fluorophore" refers to a substance or a portion thereof which is capable of exhibiting fluorescence in a detectable image. As a consequence the wording and "labeling signal" as used herein indicates the signal emitted from the label that allows detection of the label, including but not limited to radioactivity, fluorescence, chemoluminescence, production of a compound in outcome of an enzymatic reaction and the likes.

[0085] In some embodiments, the detection method can be carried via fluorescent based readouts, in which the labeled antibody is labeled with fluorophore which includes but is not limited to small molecular dyes, protein chromophores and quantum dots. In other embodiments, on-chip detection can be performed with methods other than fluorescence based techniques. Exemplary suitable techniques include, colorimetric detection, enzyme-catalyzed production of different colored or fluorescent dyes (with different colors being associated with distinct analytes), microparticle/nanoparticle based detection using electron microscopy, AFM, or dark-field microscopy, magnetic detection using magnetic micro/nanoparticles, electrical detection methods.

[0086] In some embodiments, detection can be performed by methods that use signal amplification such as gold nanoparticle based detection followed by gold or silver amplification. In particular, in some embodiments, in any of the methods and systems herein disclosed, detection can be carried out on gold nanoparticle-labeled secondary detection systems in which a common photographic development solution can amplify the gold nanoparticles as further described below. Also, if the readout comes from dark field scattering of gold particles, single molecule digital proteomics is enabled.

[0087] Additional techniques are identifiable by a skilled person upon reading of the present disclosure and will not be further discussed in details.

[0088] In embodiments wherein one or more targets and/or a plurality of targets is detected described below in more details, the labeled molecule can be formed of a plurality of labeled molecules. Each labeled molecules comprises a molecule that specifically binds one target of the one or more targets/plurality of targets and a label compound attached to

the molecule, the label compound providing a labeling signal, each labeled molecule detectably distinguishable from another.

[0089] The wording “detectably distinguishable” as used herein with reference to labeled molecule indicates molecules that are distinguishable on the basis of the labeling signal provided by the label compound attached to the molecule. Exemplary label compounds that can be used to provide detectably distinguishable labeled molecules, include but are not limited to radioactive isotopes, fluorophores, chemoluminescent dyes, chromophores, enzymes, enzyme substrates, enzyme cofactors, enzyme inhibitors, dyes, metal ions, nanoparticles, metal sols, ligands (such as biotin, avidin, streptavidin or haptens) and additional compounds identifiable by a skilled person upon reading of the present disclosure.

[0090] In embodiments, wherein bindingly distinguishable capture agents are used different analytes can be detected by use of detectably distinguishable labeled molecules each specific to a separate analyte of interest.

[0091] In some embodiments, binding of a target with a capture agent is controlled by adjusting the flow resistance of the various channels to control the saturation coverage of the capture agents by target in the plasma component conveyed in the assaying channels. In particular, in a device such as the one exemplarily illustrated in FIGS. 1 to 3, for a given concentration of detectable target in a solution, and for a given coverage of capture agents on the surface of channels (14) and (16), the time required to have saturation coverage of capture agent attached to the channels by the detectable targets is largely determined by two factors.

[0092] The first factor is given by the binding affinity which is the strength of interaction between a target and a capture agent (stronger interactions can lead to faster binding times). The second factor is the time required for a certain target to diffuse through a vessel volume to bind to a capture agent (target diffusion). In the devices methods and systems herein disclosed, flow conditions are controlled so that in a certain channel or portion thereof binding affinity or target diffusion control binding of the targets to the capture agents to various degrees.

[0093] For example, in devices wherein flow conditions are set up so that a target containing solution is not flowing through a channel, the time to saturation coverage of the target to capture agents on the channel surface is limited by the diffusion of the target in the solution. Depending upon the volume of the channel, targets diffusion to surface-bound capture agents to achieve saturation coverage can take from many minutes to hours. Assays wherein the time to saturation coverage of the target to capture agent is limited by the target diffusion are herein also indicated as diffusion limited processes.

[0094] In other embodiments, wherein a target containing solution is flowed through a channel at a sufficiently high flow velocity so that diffusion time scales are no longer relevant, only the strength of interaction (the affinity) between targets and capture agents that limits the time to saturation coverage. At this limit, the time to saturation coverage can be only 1-5 minutes. Assays wherein the time to saturation coverage of the target to capture agent is limited by the binding affinity of the target and the capture agents, are herein also indicated as affinity limited processes.

[0095] In some embodiments of the present disclosure an affinity limited process is accomplished by having the fluid move above the detection region fast enough that at every

moment, the target concentration above the capture agents remains essentially constant. More particularly, in some embodiment herein disclosed an affinity limited process can be performed by regulating the flow resistance to obtain a flow velocity of about 0.5 mm/s. In other embodiments >0.5 mm/s flow velocities in channels (14) and (16) can be obtained (regardless of their dimensions) by tuning the inlet pressure until this velocity is achieved. In the cases exemplified by FIGS. 1-6, since channels in (14) are very narrow compared to channel (16), flow velocity is much faster in channels (14) than in channels (16). Therefore an affinity limited process can be run in channels (14) even at low pressures, while diffusion limited processes can be run in channel (16).

[0096] Diffusion limited processes and affinity limited processes can differ in ways other than the timescale for completion.

[0097] A diffusion limited process, while slower, can be more sensitive than an affinity-limited process. In particular, in a diffusion limited process, capture agents such antibodies come in contact with more analytes per volume of solution than in an affinity limited process. Therefore, more analytes can be captured per unit solution volume when the process is diffusion limited, increasing the sensitivity of detection, especially when the sample concentration and volume is low.

[0098] On the contrary, an affinity-limited process allows rapid detection of a certain target in samples including the target at high concentrations. In particular, an affinity limited process can be desired when detection of a target of interest included in a sample in high concentrations and volumes because, with an affinity limited process detection of said target of interest can be efficiently performed without the need of sampling many analytes per unit of volume.

[0099] The Damkohler number (Da), which is the ratio of hybridization rate (Lr) to diffusion rate (Lm), can be used to determine if a process is affinity limited or diffusion-limited.

$$D_a = L_r / L_m$$

[0100] The hybridization rate Lr is given by:

$$L_r = k_a g_{ff}$$

where k_a is the reaction rate constant and g_{ff} is the average density of surface-bound capture agents.

[0101] The diffusion mass transport rate L_m is given by:

$$L_m = \text{cube root}[(UD^2)/(lwh^2)]$$

where U is the flow rate, D is the diffusion constant, and l, w, and h are the length, width, and height respectively. When $Da \gg 1$, (≥ 10) the reaction is occurring much more quickly than diffusion rate, so the process is diffusion-limited. When $Da \ll 1$ (≤ 0.1), the diffusion rate is fast compared to the reaction rate, and the process is affinity limited. In some embodiments, the wide channels (16) can be designed to give a $Da \geq 10$ and the narrow channels (14) can be designed to give a $Da \leq 0.1$ by inputting the appropriate parameters of length, width, and height into the above equation. The pressure can be adjusted to obtain the appropriate flow rate.

[0102] A skilled person will appreciate that if the wide channel Da (Da1) is ≥ 10 and the narrow channel Da (Da2) ≤ 0.1 , the ratio of these two channel's Da numbers should be $Da1:Da2 \geq 100$. Also Lr, h, and D (diffusion constant) are equal in both the narrow and wide channels and

$$Da1:Da2 = Lm2:Lm1 = \text{cube root}(U_2 l_1 w_1 / U_1 l_2 w_2)$$

wherein L_{m1} =mass transport rate in the wide channel and L_{m2} =mass transport rate in the narrow channel

[0103] In some embodiments, each narrow channel (14) can have a flow rate that is $1/5$ of the flow rate of the wide channel (16) so $U_2=1/5U_1$ and the lengths of narrow and wide channels are often about equal. In those embodiments, the equation can be simplified to:

$$Da_1:Da_2=\text{cube root}(w_1/5w_2)$$

[0104] A skilled person can then solve for w_1/w_2 to obtain the ratio of wide channel:narrow channel needed to obtain diffusion limitation in one channel and affinity limitation in the other channel.

[0105] However, the Damkohler number does not take into account the flow-velocity dependence of the binding process. Therefore, in some embodiments wherein calculation of flow-velocity dependence is desired, a more suitable model is the Zimmermann model.

[0106] Reference is made to a passage from Zimmermann, M. et al. "Modeling and Optimization of High Sensitivity, Low Volume Microfluidic-Based Surface Immunoassays." *Biomedical Microdevices* 7:2, 99-110, 2005, pp. 100-101, reported in the following paragraph [00108].

[0107] "The flow of a liquid in a region over time t is characterized by a velocity vector field \vec{u} a pressure p and a density ρ . For laminar, incompressible and viscous fluids the density is constant. The flow is described by the Navier-Stokes partial differential equation system

$$\frac{\partial}{\partial t} \vec{u} + (\vec{u} \cdot \text{grad}) \vec{u} + \text{grad } p = \frac{1}{Re} \Delta \vec{u} + \vec{g} \quad (1)$$

$$\text{div } \vec{u} = 0 \quad (2)$$

in dimensionless form with the Reynolds number Re and external forces \vec{g} . External forces such as gravity can be neglected in such miniaturized systems. For $Re \ll 2100$, flow is considered to be laminar and has a characteristic parabolic flow profile with zero flow velocity at the channel walls and peak flow velocity in the channel center. Here, Re is ~ 0.07 for the maximum flow rates considered.

[0108] The bulk concentration C of a solute in a given solution is described by the Convection-Diffusion equation of the form

$$\frac{\partial C}{\partial t} + \vec{u} \cdot \text{grad } C = D \Delta C + \Theta(t, x, y, C)$$

with a diffusion coefficient D , a source term Θ and the identical velocity vector field \vec{u} given in equation (1). We have applied the Stokes-Einstein-relation

$$D = \frac{kT}{6\pi \eta R_h}$$

with the hydrodynamic radius R_h , the analyte viscosity η and the Boltzmann constant k to estimate the diffusion coefficient D of the analyte molecule to $D=10^{-6} \text{ cm}^2\text{s}^{-1}$ which we used for all further calculations and which corresponds to the literature (Metsämuronen et al., 2002) where comparable

values for small molecules such as $\text{TNF}\alpha$ —are reported. The analyte viscosity was set to a high plasma viscosity (Koenig et al., 1998) of 2 mPa s.

[0109] The association and the dissociation from the capture site are described by the rate coefficients k , the analyte concentration C and the density of free binding sites ($\Theta_{max} - \Theta_t$) on the surface, using an ordinary differential equation of the form,

$$\frac{d\Theta_t}{dt} = k_{on} C (\Theta_{max} - \Theta_t) - k_{off} \Theta_t$$

for monovalent receptors and ligands. k_{on} is the rate constant for association, k_{off} is the rate constant for dissociation, C is the concentration of free molecules in the fluid, Θ_t is the surface density at time t Θ_{max} is the maximum surface density of molecules calculated from the feature area of the individual capture molecules and is assumed to be constant over time. In this simulation we generally used $10^6 \text{ M}^{-1} \text{ s}^{-1}$ for k_{on} and 10^{-3} s^{-1} for k_{off} (Santora et al., 2001), but in some case these constants were modified." (Zimmermann, M. et al. "Modeling and Optimization of High Sensitivity, Low Volume Microfluidic-Based Surface Immunoassays." *Biomedical Microdevices* 7:2, 99-110, 2005, pp. 100-101)

[0110] In some embodiments, the equations from the Zimmermann passage can be used to determine the flow rate associated with affinity limited vs. diffusion limited processes. In particular, using a simulation incorporating the Zimmermann equations, an analyte concentration of 1 pM, and an antibody binding affinity of $K \sim 10^9$, and feature sizes of 1500 nm^2 , flows above 0.5 mm/sec can be considered affinity limited whereas flows around 0.005 mm/sec can be considered diffusion-limited. More particularly flows of 0.05 mm/sec can be considered at the beginning of the diffusion limited regime. As a consequence, a 10-100 fold difference in flow velocity can be identified between the diffusion limited and affinity limited regimes.

[0111] Accordingly, in certain embodiments, wherein diffusion limited processes and affinity limited process in assaying channels of a same device are desired, the affinity limited region can be about 10-100 times narrower than the diffusion-limited region (regardless of length, and all heights are constant), wherein the specific dimensions of the affinity limited region (plasma channels) are also dictated, by separation efficiency (possibly optimized with yield and flow rate) (see above and Appendix A). In some embodiments, the flow rate through the plasma channels can be adjusted simply by increasing the pressure until fluid through those channels is moving at a speed of about 0.5 mm/sec (affinity limited regime). In some embodiments, as long as the wide channel (16) is about 10-100 times wider than the combined width of the narrow channels (14), the flow velocity will be about 0.05-0.005 mm/sec (diffusion limited regime). In one embodiment, the narrow channels (14) are 10 μm and there are 5 of them, for a combined width of 50 μm . In some embodiments, the wide channel (16) can be 500 μm wide to obtain a 10-fold reduction in flow speed. In other embodiments, wherein channel (16)'s width is increased to 2-5 mm, region (16) of the device would still be within the diffusion limited regime (0.005 mm/s).

[0112] In accordance with the present disclosure, channels or portions thereof and in particular assaying channels (14)

and (16) can be designed to host either diffusion-limited processes or affinity limited processes by varying the width of the channel.

[0113] In particular, in some embodiments, the channels are designed so that binding of the capture agents to targets in the fluid component is an affinity limited process. For example, in the embodiments exemplarily illustrated, FIGS. 1-6, channels (14) and (16) are in series so they will have the same volume flow rate by conservation of mass. Therefore, in those embodiments if channel (14) is much narrower, e.g. 50-1000 \times , than channel (16), the fluid velocity must be much faster through (14) than through (16) in order for their volume flow rates to be equal. This velocity difference leads to a difference in analyte exploitation and binding efficiency between the two channels. It is clear from the above equation that varying the l , w , and h of the channel can be used to increase or decrease the Lm term, thereby increasing or decreasing the Damkohler number. The l , w , and h can be increased to decrease the Damkohler number far below 1 to obtain an affinity-limited process and far above 1 to obtain a diffusion-limited process.

[0114] In particular, in a device such as the one exemplified in FIGS. 1 to 6, the two plasma assay regions (14, 16) on the chip can be harnessed for different purposes. When the chip is being operated for the separation of plasma from whole blood, the plasma flows rapidly through the thin channels (14), but only flows slowly through the reservoir (16). Thus, if (14) is utilized for measuring the levels of plasma proteins, then such an assay will be an affinity limited process, and saturation coverage of targets to surface-bound capture agents can be completed within a few minutes. By contrast, if (16) is the region utilized for measuring the levels of plasma proteins, then plasma flow through that region is slow, and the processes is diffusion limited but relatively more sensitive.

[0115] In particular, in the embodiments exemplified in FIGS. 1 to 6, the greatest fluid velocity within the detection region (11) is in the plasma channels (14) and therefore the best binding efficiency occurs in this region, so the signal/unit area should be highest here. Velocity can be increased in this region by increasing the inlet pressure.

[0116] In the illustration of FIGS. 1 to 6, channel (14) is much narrower than channel (16) so that the velocity in channel (14) will be above the threshold velocity (e.g. 0.5 mm/s) for a given pressure while channel (16) should be wide enough that the flow velocity is below the threshold velocity. Threshold velocity is that flow velocity at transition between diffusion limitation and affinity limitation.

[0117] An embodiment of channels (14) and (16) is illustrated in more detail in FIG. 2. In the embodiment, illustrate in FIG. 2, plasma channels (14) are long and narrow to achieve a high resistance relative to channel (15), thereby accomplishing the plasma skimming. The dimensions of the 5 plasma channels (14) of FIG. 2 can be about 10 μ m wide, about 25 mm long. Channel (16) can be about 500 μ m wide and about 10 mm long. The length of channel (15) can be 100 μ m.

[0118] In some embodiments, the channel (15)'s width is in the range of about 20-40 μ m, in those embodiments clogging of a sample such as blood decreased considerably.

[0119] In some embodiments, wherein blood is treated with anticoagulants immediately upon finger-prick blood draw, and the sample is immediately run into the blood inlet, the device can be run for extended time period, such as hours without clogging. In some embodiments, once the channel

dimensions are determined according to the experimental design of choice, and in particular within the ranges indicated above for optimized separation, yield and assay timing, the width of channel (15) can be increased to diminish a possible clogging effect. For example, for sample blood the width of channel (15) can be increased from 15 μ m, to 25 μ m, 35 μ m. The desired width can be selected in view of the dimension of the particle that can clog channels in the device, considering the desired separation efficiency, and detection settings. The above exemplary widths of channel (15) are indicated for particles and in particular cellular aggregates with sizes in the 0-25 μ m range.

[0120] In some embodiments channels in region (14) are about 5 mm long. In other embodiments the plasma channels are lengthened to about 15-25 mm, to minimize the number of cells that flow over the detector, decreasing the chance of biofouling or signal interference in the detector region.

[0121] In embodiments, all plasma channels designed to be about 10 μ m wide and about 10 μ m high regardless of length. Higher heights (e.g. as high as 15-20 μ m can be used without affecting device performance). In those embodiments, the plasma separation improved as the length of the channels was increased from 5 mm to 15 mm to 25 mm.

[0122] In devices methods and systems herein disclosed, channels can be designed so to control plasma separation from channel (15) to channel (14) as herein described and have predetermined channels or portions thereof configured to host affinity limited processes or diffusion limited processes. In those embodiments, the dimensions are optimized to control plasma separation and reactions performed in assaying channels of the device.

[0123] In some embodiments, the heights of the channels in the entire device can be held constant (at about 10 μ m), the width of plasma channels (14) (affinity limited region) can be held at about 10 μ m, and the width of channel 16 10-100 times larger than channels (14).

[0124] Other embodiments can be identified by a skilled person upon reading of the present disclosure, also applicable to samples other than blood considering that for an n -fold difference between calculated affinity-limited and diffusion-limited velocities (based on the equations of the Zimmermann model), the wide plasma channel (16) should be designed n times wider than the narrow plasma channels (14).

[0125] FIG. 3 shows an additional embodiment wherein channels (15), (14) and (16) are illustrated in connection with other portions of the device, such as blood inlet (12), a lysis inlet (17), a primary reagent inlet (18), a labeled molecule inlet (19) and whole blood outlet (10).

[0126] In some embodiments, the blood sample is introduced into blood inlet (12) and conveyed into the flowing channel (15). The plasma is then separated into assaying channels (14) and (16) wherein the biomarker is contacted and bound with the capture agent of choice in a detectable complex.

[0127] The whole blood is disposed through the whole blood outlet (10). A lysis buffer can be also included in the lysis inlet (17) to prevent clogging of the whole blood by lysing the blood cells. A labeled molecule (e.g. a secondary antibody) can be added through the labeled molecule inlet (19) to detect the detectable complex of the assaying channels (14) and (16).

[0128] Each of the inlets shown in FIG. 3 can be primed by closing the main inlet control valve and allowing the sub-inlet solution to flow out of inlet (6) to remove any air bubbles prior

to flowing into any of the eight devices. Each of the devices can be actuated independently in this design, such that up to 8 time points of serum protein expression can be obtained from a patient or mouse model.

[0129] Various embodiments can be envisioned including a different number of inlets. In one embodiment, all the devices are connected by common inlets as mentioned before, so buffers and reagents can be delivered to all devices from one common inlet. In another embodiment, a number of completely independent devices, each having its own inlet, can be included in the same frame. Another embodiment, a plurality of devices is included in one frame, with a common buffer/reagent inlet for all the devices, with each having an independent blood/sample inlet for each device (to avoid cross-contamination of samples).

[0130] In other possible embodiments, devices can have a plurality of plasma separation channels (14), e.g. from 2 to >100, and/or additional channels for introducing reagents into the device before and after the blood separation is performed. For example, in some embodiments, various reagents (capture, detection, blocking, wash agents, etc) can be introduced through channels in direct fluidical connection with channel (16) rather than having to flow reagents through the thin, long, high-resistance plasma channels (14). In those embodiments, experiment/assay times for region (16) as well as clogging of region (14) plasma channels can be decreased.

[0131] In other embodiments, reagents comprising capture agents, detection agents, and other reagents identifiable by a skilled person can be mixed with the sample prior to introduction into the device rather than sequentially flowing each fluid separately.

[0132] In some embodiments, additional channels that can be envisaged include a lysis buffer channel such as lysis channels (17) of FIG. 3, that enters region (13) and lyses the cells as they enter that region to prevent cell-clogging of the outlet (and/or post-13 reservoir), helping to increase operation times. Lysing cells proximate to the outlet minimizes increasing resistance at outlet over time, which eventually leads to device failure thus prolonging the life of the device.

[0133] Other embodiments might include on-chip channels and reactors before the separation region channels, in particular before channel (15), to pre-treat the blood before it enters the separation region. These channels may house diluent buffer to dilute the whole blood as it enters; other buffers; anticoagulant; biological solutions and fluids; solutions of proteins, DNA, RNA, or other biomolecules; chemical reagents, oils, etc. These reagents might be housed in channels and reservoirs on chip for addition to blood—with or without mixing—or for addition to one of the other immunoassay steps—with or without mixing—. For on-chip mixing of whole blood, separated plasma or other immunoassay reagents either with each other or with any additives whether mentioned above or otherwise, on-chip rotary mixers driven by micromechanically controlled peristaltic pumps may be used (see for example equipment described in Hong J W, et al. A nanoliter-scale nucleic acid processor with parallel architecture. *Nature Biotechnology*. 2004. 22, 4: 435-439. that are contiguous with region (15), (13), (14), or (16). Or any other state-of-the-art microfluidic mixing components might be used: herring bone; cross over/zig-zag channels; thin channels for diffusion based mixing, etc.

[0134] Other embodiments can include specific elements that enable or improve introduction and circulation of a sample or reagents in the device including: a pump to apply an

external pressure to the sample and/or reagents, a piston to apply mechanical pushing to one or more fluids in the device with a plug at the device inlet, a peristaltic pump on chip, a device that applies vacuum at a chip exit, a device that provides electrokinetic transport and/or any other equipment by which a force can be applied to drive the fluid through the channels.

[0135] Other embodiments can include on-chip (post 14 or post 16) additional assaying channels/modules for amplification of a polynucleotide (e.g. DNA or RNA) or a polypeptide (e.g. proteins) for improved signal detection from blood, plasma, or serum. These could include on-chip modules that perform PCR, RT-PCR, immuno-PCR, RCA, nanoparticle-based biobarcode detection, etc. In those embodiments detection and/or quantitation of a certain target can be performed through the capture in those modules of PCR and RT-PCR amplicons, barcode DNAs in nanoparticle based detection and/or of proteins, RNA, DNA, and/or any other surrogate/relay biomolecule that is capturable by existing capture agents and is indicative of the presence of a biomolecule other than itself. An exemplary device including an assaying channel is depicted in FIG. 4, wherein channel (171) indicates a region of the chip's flow layer where PCR, RT-PCR, or immunoPCR can be performed. In the exemplary embodiment of FIG. 3A, the DNA products could then be detected by the DNA capture strands in region (16).

[0136] In some embodiments, a plurality of devices can be included in the same frame and in particular can be adapted to perform multiple assays, so that an assay step in one device is to be completed earlier than in other devices. In those embodiments, control valves can be included in the devices at the ends of regions (13) and/or (16) to minimize backflow and contamination of the assaying channels. More particularly in some embodiments, a mechanism can be included to control fluids movement between assays steps, so that at the end of an assay step, the valves can be turned on, stopping the movement of fluid while the device is readying for the next step. In some of those embodiments, the valve at the end of region (13) can also have the function of allowing reagents to be delivered only through the assaying channels (14) and (16) to minimize flowing of the reagent through channel (13), and maximize conveyance of the reagents into assaying channels (14) and (16). Exemplary control valves are illustrated in FIG. 5, wherein control valve (113) and control valve (116) are schematically illustrated.

[0137] A control valve upstream of region (15) can also be included in each of a plurality of devices included in a same frame. In those embodiments, the control valve can be opened to allow sample and reagents to only enter the device in a controlled fashion and can be closed to minimize backflow of sample into the common inlet region or into other assay devices in the frame. An exemplary schematic illustration of this valve is depicted in FIG. 6, wherein valves (112) and (115) are shown.

[0138] In embodiments wherein a plurality of devices are included in a same frame, an additional control valve actuating the common channel fed by multiple inlets (e.g. six) of the devices can also be included. This valve can be closed to allow priming of buffers and samples prior to flowing through the device and to minimize air bubbles. (see FIG. 6)

[0139] In some embodiments the capture agents include one or more components. In particular, in some embodiments the capture agents can be formed by a substrate polynucleotide and a polynucleotide encoded-protein in application of

the technology (herein also identified as DEAL) described in U.S. patent application Ser. No. 11/888,502 herein incorporated by reference in its entirety.

[0140] Accordingly, the wording “substrate polynucleotide” as used herein refers to a polynucleotide that is attached to a substrate so to maintain the ability to bind to its complementary polynucleotide. A substrate polynucleotide can be in particular comprised of a sequence that specifically binds and is thereby defined as complementary with an encoding-polynucleotide of a polynucleotide encoded protein.

[0141] The wording “polynucleotide-encoded protein” refers to a polynucleotide-protein complex comprising a protein component that specifically binds to, and is thereby defined as complementary to, a target and an encoding polynucleotide attached to the protein component. In some embodiments, the encoding polynucleotide attached to the protein is protein-specific. Those embodiments can be used to perform assays that exploit the protein-specific interaction to detect other proteins, cytokines, chemokines, small molecules, DNA, RNA, lipids, etc., whenever a target is known, and sensitive detection of that target is required. The term “polynucleotide-encoded antibody” as used herein refers to a polynucleotide-encoded protein wherein the protein component is an antibody.

[0142] In the polynucleotide-encoded proteins herein disclosed each protein specifically binds to, and is thereby defined as complementary to, a pre-determined target, and each encoding polynucleotide-specifically binds to, and is thereby defined as complementary to, a pre-determined substrate polynucleotide.

[0143] In embodiments wherein the protein is an antibody, the protein-target interaction is an antibody-antigen interaction. In embodiments wherein the protein is other than an antibody, the interaction can be receptor-ligand, enzyme-substrate and additional protein-protein interactions identifiable by a skilled person upon reading of the present disclosure. For example, in embodiments where the protein is streptavidin, the protein-target interaction is a receptor-ligand interaction, where the receptor is streptavidin and the ligand is biotin, free or attached to any biomolecules.

[0144] The advantages associated with the application of DEAL to the chip herein disclosed are multifold. First, the fact that polynucleotide hybridization is utilized as an assembly strategy allows for multiple proteins to be detected within the same microenvironment, since the capture agents for the distinct proteins can each be labeled with a different single stranded polynucleotide oligomer. Second, antibodies are stable within a relatively narrow range of salt concentration, pH, and temperature, which means that the surfaces onto which antibodies are attached are not robust in the face of drying and heating. Thus, antibodies generally must be attached to the surface immediately prior to use. The instability of antibodies also makes protein assays difficult to execute within microfluidics environments, since the antibodies do not survive the microfluidic fabrication process. Using polynucleotide hybridization as an assembly strategy circumvents these problems because polynucleotides are stable under fabrication conditions, and polynucleotide-patterned surfaces can be prepared ahead of time, dried out, heated, shipped around if need be, and so forth. In the present work, the thirteen-protein panel used in the serum test was designed as follows.

[0145] In some embodiments, wherein antibodies are conjugated to polynucleotides, the stoichiometric proportions of SANH and antibody can be modified/optimized for each antibody-polynucleotide conjugation reaction. If the same SANH:antibody ratio as was used in panels with just a few conjugates (Kwong, G. DEAL Encoded Antibody Libraries. JACS. 129(7):1959-1967, 2007.) is used in all conjugation reactions, some antibodies end up with few to no polynucleotides and others are overloaded. In those embodiments, the SANH:antibody ratio therefore can be optimized for each antibody by trying a range of SANH concentrations and then determining the number of polynucleotides attached to each antibody by gel electrophoresis.

[0146] In some embodiments, wherein a plurality of substrate polynucleotide is attached to an assaying channel, to minimize cross-talk between different spots/strips on the assaying channel, dye-conjugated polynucleotide, such as DNAs with sequence complementary to just one of the substrate polynucleotides can be run through the device to exclude sequences providing a signal greater than a threshold predetermined in view of the experimental design. For example, in some embodiments the non-complementary sequences giving a signal greater than 4% of the complementary sequences, were excluded. In those embodiments, selection of substrate polynucleotides can be optimized to minimize cross-reactivity in accordance with the experimental design.

[0147] In some embodiments, to further minimize cross-talk between different spots/strips on an assaying channel, it was important to make sure that polynucleotide-conjugated antibodies maintained their specificity after conjugation. Therefore, control assays were run to maximize the polynucleotide-conjugated antibodies that maintain their specificity. In particular, in a control assay a single recombinant standard diluted in buffer can be run over the on-chip DEAL detection array. If spots/strips other than the one specific for the recombinant show a detectable signal, the related antibodies/DEAL conjugates were excluded from future use.

[0148] In some embodiments, to increase the dynamic range detectable within the same detection region, the DNA loading during the slide-patterning can be varied. In particular, Polynucleotides associated with analytes at low concentrations such as cytokines that are found at concentrations in the femtomolar-picomolar range can be patterned with very high loading concentrations, whereas those associated with high concentration analytes such as albumin that occurs in the millimolar range can be patterned at low loading concentrations.

[0149] In some embodiments, DEAL capture agents to analytes with similar blood concentrations are attached in the same lane, and a plurality of devices can be included in a same frame, each device measuring analytes within similar concentration ranges. For example, one device can measure cytokines only, while another measures just high abundance proteins (such as albumin and fibrinogen). In those embodiments, all the devices can be connected by a common inlet so the same blood sample is run through multiple devices separately but simultaneously. Each of these devices can still maintain the same surface polynucleotide pattern in their detector region, but different antibodies are conjugated to the complementary polynucleotides.

[0150] In some embodiments, the capture agents, which include but are not limited to the capture agents according to the DEAL approach, array can be printed either as separate

spots using a microarray patterning machine, or it can be patterned as a capture agent bar code using a separate microfluidic mold. Additional details concerning barcoding patterning are described in the related US Application entitled "Arrays, Substrates, Devices, Methods and Systems for Detecting Target Molecules" Serial No. to be assigned filed on Jul. 16, 2008, herein incorporated by reference in its entirety.

[0151] In comparison to conventional spotting, the bar code method allows for smaller feature sizes and higher feature densities, characteristics which translate into higher information densities as well as higher assay sensitivity.

[0152] An exemplary illustration of a barcoded pattern is provided by the configuration of channel (16) in FIG. 2. In particular, in the embodiment of FIG. 2, channel (16) is long enough to accommodate 4 iterations of a barcode patterned on the glass beneath it (see FIG. 11 and related description below).

[0153] A further exemplary chip including a barcoded assaying channel is shown in the schematic illustration of FIG. 7. In the diagram, whole blood flows from an inlet (32) downward into the whole blood outlet (30), while separated plasma flows in the flowing channels (35) to the right through the narrow assay channels (34) which include affinity assay channels (344) and diffusion assay channels (346) corresponding respectively to channel (14) and (16) of the device of FIG. 1-3. The plasma eventually exits into a wider channel which covers the encoded DNA array. A reagent input (37) a reagent drain (39) and a control valve (38).

[0154] In the illustration of FIG. 7, the microfluidic network is aligned such that the cell-free plasma channel regions overlap the array of capture agents. In the above design, 6 sub-inlets feed into the main inlet, such that one of up to 6 distinct fluids can be fed into the device, one at a time, by actuating the appropriate sub-inlet control valve. This is not necessary for the disclosure, but it adds to both the ease of operation and the flexibility of the chip operation.

[0155] The device herein disclosed can be manufactured according to various procedures herein disclosed. FIG. 8 shows an exemplary process for manufacturing the device of FIGS. 1 to 6 which includes spotting (panel A), patterning (Panel B) and sealing (Panel C) the microfluidic chip. In the illustration of FIG. 8, the base of the chip is a support or base layer (20). In some embodiments base layer (20) is made of a clear and smooth material, such as glass or smooth plastic that is molded into the substrate using techniques known to the skilled person. Arrays of protein capture agents (21) are then spotted onto the surface of substrate (20) using any one of a number of methods known in the art (see Panel A). In embodiments wherein detection of multiple targets is desired, the capture agents are spotted so that they are positionally distinguishable one from the other so that the identities of the target can also be verified by their spatial location relative to one another.

[0156] In some embodiments, once the capture agents are deposited, a channel layer (22) that contains a microfluidic design for the separation of plasma from whole blood is deposited on top of base layer (20) (Panel B). The channel layer is designed to form the walls of channels having as base portions of the substrate (20). Channel layer (22) is bonded to the support (20) so that leakage of fluid between support (20) and channel layer (22) is minimized and fluid only flows through the channels (15, 14, 16).

[0157] In some embodiments, alignment markers can be co-deposited along with the capture agent spots (21). Alignment markers are features that are placed/deposited on the support (20) (e.g. a glass slide) and at complementary positions on the device, to align the device to an exact location of choice on the support (20). In those embodiments the individual sets of protein capture agent spots (21) may be patterned arbitrarily over the surface of the substrate (20). As long as that patterning process results in a density of capture agents spots, such that the desired detection region covers at least one complete set of distinct spots independently on the location of the device on the base layer. (20), then alignment of the channels on channel layer (22) with the capture agent spots (21) is optional. This is because, in the example of FIG. 8, each assaying channel will be guaranteed of having at least one full set of capture agent spots in both the narrow channel regions (14) (for rapid measurements) and the large channel region (16) (for more sensitive measurements). The density for a specific device depends on the length of the device's detection region, the size of the spots, and the spot spacing. For example, for twenty spots that are 20 μm diameter and spaced 30 μm apart, the detection region (channel 16) would have to be at least $(20 \mu\text{m} + 30 \mu\text{m}) \times 20 \text{ spots} = 1 \text{ mm}$. So for our detection region, which is 10 mm, this would be considered a sufficiently high density to not require alignment marks.

[0158] Channel layer (22) and base layer (20) may be also fabricated from the same material, such as an etched glass wafer or a molded polymer material. The array of protein capture agents can then be spotted onto the channels. However, it is expected that such an approach would be difficult to carry out, since the thin microfluidics channels (14) are typically smaller (10 to 20 micrometers wide) than the resolution of most capture agent spotting methods. A top layer (23) can then be sealed onto (22) so that fluid cannot flow in the spaces in between the layers, except for in the channel regions (Panel C).

[0159] In other embodiments, channel layer (22) and top layer (23) may be made from the same film, which is then bonded onto base layer (20). However, top layer (23), whether or not joined with channel layer (22) and molded from the same material, or made from a different layer, top layer (23) can also be equipped with entrance and exit holes for the whole blood and the blood waste, as well as for a hole over (16) to permit the flow of plasma without pressure buildup.

[0160] In some embodiments, parts of the surfaces (14, 15, 16, 22, 23) that are not coated with capture agents and are part of the channels that are exposed to either blood or serum are coated with antifouling material, such as bovine serum albumin, polyethylene glycol material, or some other material that resists non-specific protein adsorption.

[0161] In some embodiments, the assaying channels are spotted with capture agents. In other embodiments they are patterned and in particular barcoded. In particular, in some embodiments the chip includes patterned DNA arrays to assemble (complementary) DNA'-labeled antibodies or other capture agents. Once the chip is fully assembled, the DNA'-labeled capture agents are assembled to the DNA array via flowing them the capture agents through the microfluidics channels and allowing them to assemble onto specific locations via DNA-hybridization.

[0162] The process, also shown in the schematic illustration of FIG. 9 and exemplified in Examples 2, 4 and 5, allows an easier preparation of the protein arrays to be used in the device herein disclosed. Antibodies are not stable at elevated

temperatures, or up dehydration. Both of those conditions can apply when microfluidics chips are fabricated and assembled together. DNA, by contrast, is stable to moderate elevated temperatures (~100-150° C.) and dehydration.

[0163] In some embodiments, the chip may be batch fabricated using common and inexpensive materials, such as glass or plastic.

[0164] In some embodiments, the chip has no moving parts and no electrical inputs and outputs and the chip relies entirely on hydrodynamic flow design to separate plasma from blood and to expedite the measurement of protein levels from that plasma.

[0165] In some embodiments a non-DEAL capture agent (e.g. in a capture agent solution) can be patterned to the support before bonding the blood separation microfluidic device to the support. In a prophetic example, if at least two distinct antibodies or other protein capture agents (antigen, for example) are patterned on a slide such as base layer (20) of FIG. 5, in a spatially separate or non-spatially separate fashion, the PDMS device is expected to be possibly placed on the patterned slide without heat treatment. The device is expected to still be functional but will only operate at a very low pressure (e.g. 1-2 psi) which is expected to affect fast assay times. In another prophetic example, peptides or aptamers can be pre-patterned on a slide and are expected to withstand the higher heat treatment associated with strong bonding of the PDMS device with the slide.

[0166] In some embodiments, after bonding the PDMS to a non-prepatterned glass slide, introduce at least two distinct capture agents into the device inlet and flow the solution through regions (15), (14), and (16) and out the exit to coat the walls with capture agents. The sample can then be run and fluorophore-conjugated detection agents (detection antibody, protein, DNA, RNA, aptamer, etc) can be run through. Each analyte can then be detected by detectably distinguishable labels.

[0167] Other embodiments could include the capture agents being adsorbed to the channel walls, rather than restricted to the slide surface.

[0168] In some embodiments, the chip design permits for multiple blood based protein biomarkers to be measured from a very small aliquot (~2-3 microliters) of whole blood. In those embodiments, the numbers of biomarkers measured are limited by two factors. The first is the cross reactivity of the protein capture agents—if the agents are not sufficiently selective for their cognate proteins, then cross-reactivity will limit the assay sensitivity and the numbers of proteins that can be measured simultaneously. The other factor is the spot size and separation distance of the spotted capture agents.

[0169] In some embodiments, the chip design permits for multiple measurements of each of the blood protein biomarkers, since each thin plasma channel (14) can contain multiple sets of capture agent spots, and so multiple channels translate into multiple measurements. This increases the accuracy of the measurements, without increasing the amount of blood needed.

[0170] In some embodiments, the chip design permits for the measurement of blood protein biomarkers, within a few minutes. This time scale is faster than most chemical processes that can degrade molecules in the blood.

[0171] In some embodiments, the entire process, from blood sample introduction, to protein levels measurement, may be automated. This minimizes human intervention, associated error, etc., and reduces cost.

[0172] In some embodiments, multiple designs such as that shown in FIG. 8 may be replicated on a single chip, further decreasing the cost of the measurements by allowing for multiple blood samples to be analyzed on the same chip, without increased effort in chip fabrication.

[0173] The systems herein disclosed can be provided in the form of arrays or kits of parts. An array sometimes referred to as a “microarray” includes any one, two or three dimensional arrangement of addressable regions bearing a particular molecule associated to that region. Usually the characteristic feature size is micrometers. FIGS. 13 and 14 provide exemplary microarrays.

[0174] In a kit of parts, capture agents and devices are comprised in the kit independently. The capture agents, e.g. polynucleotide-encoded protein for DEAL technology, are included in one or more compositions, and each capture agent is in a composition together with a suitable vehicle carrier or auxiliary agent.

[0175] The device provided in the system can have substrate polynucleotide attached thereto. In some embodiments, the substrate polynucleotides can be further provided as an additional component of the kit. Additional components can include labeled polynucleotides, labeled antibodies, labels, microfluidic chip, reference standards, and additional components identifiable by a skilled person upon reading of the present disclosure. In particular, the components of the kit can be provided, with suitable instructions and other necessary reagents, in order to perform the methods here disclosed. The kit will normally contain the compositions in separate containers. Instructions, for example written or audio instructions, on paper or electronic support such as tapes or CD-ROMs, for carrying out the assay, will usually be included in the kit. The kit can also contain, depending on the particular method used, other packaged reagents and materials (i.e. wash buffers and the like).

[0176] Further details concerning the identification of the suitable carrier agent or auxiliary agent of the compositions, and generally manufacturing and packaging of the kit, can be identified by the person skilled in the art upon reading of the present disclosure.

EXAMPLES

[0177] The methods and system herein disclosed are further illustrated in the following examples, which are provided by way of illustration and are not intended to be limiting the scope of the present disclosure.

Example 1

Fabrication of a Chip for Plasma Separation and Analysis from a Whole Blood Sample

[0178] A device for plasma separation according with the present disclosure was manufactured as follows. Control valves and fluidic channels were fabricated in PDMS. The device was then bonded to a DNA microarray glass slide.

[0179] The design of the integrated separation-assay chip is shown in FIG. 3. The fluidic channels were fabricated from PDMS and then bonded to a glass slide on which a DEAL array has been printed. The microfluidic network was aligned such that the cell-free plasma channel regions overlap the array.

Example 2

Fabrication and Use of an Blood Separation and Analysis Deal Device Using

[0180] An integrated separation DEAL device was manufactured and used as shown in the schematic illustration of FIG. 9.

[0181] Strips of ssDNA oligomers were deposited onto a poly-lysine coated glass substrate using a layer of PDMS with microfluidic channels molded into it (Panel a). The PDMS was removed, leaving behind strips of ssDNA (panel b). An antibody array was formed using DNA-hybridization to assemble ssDNA'-labeled antibodies into the appropriate spatial locations (Panel c). Detection of a target protein was then performed following standard ELISA, or sandwich-like protein assays (Panels d to f). The exception is that all antibodies designed for protein detection are labeled with red fluorescent dyes (Cy5) for protein readout. One ssDNA strip has no associated antibody—this is the alignment marker, and hybridization with ssDNA' labeled with a green fluorophore (Cy-3) provides a reference location for the antibody array.

Example 3

Manufacture and Use of a Chip Including the Deal Technology

[0182] An integrated microfluidic chip which performs blood handling and rapid plasma separation on low volumes of blood; and protein detection and quantitation using DEAL technology was manufactured and used.

[0183] According to a first series of experiments a microfluidic network was placed in contact with a DNA array. Distinct antibodies tagged with signature cDNA sequences were then flowed over the DNA array, where they localized to the DNA spots by hybridization of their ssDNA tag with the complementary ssDNA spot on the slide, forming a DNA Encoded Antibody Library (or DEAL) array. The blood sample (<10 uL) is delivered to the plasma skimming region of the device. The separated blood plasma was flowed over a region of the chip containing the DEAL array, at which point the various analytes to be targeted are bound by capture antibodies at pre-defined locations on the array. A solution of biotin-conjugated detection antibodies was then delivered to the DEAL array region to form an ELISA-like sandwich with the analyte and capture antibody. Gold nanoparticle-conjugated streptavidin was then directed to the array region, and the array was then developed by gold amplification, so that the resulting protein expression profile of the sample can be read directly off the slide. Alternatively, CyDye-conjugated streptavidin can be used and the intensities of DEAL array spots or bars can be measured using fluorescence.

[0184] According to a second series of experiments for protein detection using DEAL, the method was as follows: Capture antibodies (CAs) against the protein of interest were

chemically labeled with single-stranded DNA (ssDNA) oligomers, yielding ssDNA-CA conjugates. The coupling reaction is accomplished using SFB/SANH-based conjugation chemistry to link amine termini on DNA oligomers to the amine side-groups of proteins. A size-exchange column is used to purify the product by removing excess unreacted DNA molecules. Separately, the complementary ssDNA oligomers are deposited in a barcode pattern on a poly-L-lysine-coated glass slide using microchannel-guided patterning. At the beginning of a DEAL protein assay, incubation of ssDNA-CA conjugates with the complementary ssDNA array assembles the capture agents onto those specific sites through DNA hybridization.

[0185] This step transforms the DNA microarray into an antibody microarray that is ready for a protein sandwich assay. At this point, samples (i.e. plasma separated from human whole blood) can be applied onto the CA microarray and antigens can be captured. Finally, detection antibodies and/or fluorescent read-out probes are introduced sequentially to complete the immuno-sandwich assay. DNA oligo sequences are chosen with appropriate melting temperatures to optimize room-temperature hybridization to complementary strands while minimizing cross-hybridization (<5% in fluorescence signal).

[0186] In particular, a panel of blood protein biomarkers was detected from a fingerprick of human blood. The protein panels used, along with the corresponding DNA codes, and their sequences are summarized in Table 1 and 2. These DNA oligomers were synthesized by Integrated DNA Technologies (IDT), and purified by high pressure liquid chromatography (HPLC). The quality was confirmed by mass spectrometry.

TABLE 1

List of protein panels and corresponding DNA codes.		
Biomarker Panel		
AA/AA'	Interleukin-1beta	IL-1β
BB/BB'	Interleukin-6	IL-6
CC/CC'	Interleukin-10	IL-10
DD/DD'	Tumor necrosis factor-alpha	TNF-α
EE/EE'	Complement Component 3	C3
FF/FF'	C-reactive protein	CRP
GG/GG'	Plasminogen	Plasminogen
HH/HH'	Prostate specific antigen (total)	PSA

TABLE 2

List of DNA sequences used for spatial encoding of antibodies			
Sequence Name	Sequence	SEQ ID NO:	Tm (50 mM NaCl) ° C.
AA'	5' NH3 - AAAAAAAAAAAGT CACAGACTAGCCACGAAG - 3'	1	58
BB	5' - AAAAAAAAAAAGCGTGTGTGGACTCTCTCTA - 3'	2	58.7
BB'	5' NH3 - AAAAAAAAAATAGAGAGAGTCCACACACGC - 3'	3	57.9
CC	5' - AAAAAAAAAATCTCTAGTTGTGCGAGCAGG - 3'	4	56.5
CC'	5' NH3 - AAAAAAAAAACCTGCTCGACAACCTAGAAGA - 3'	5	57.5
DD	5' - AAAAAAAAAAGATCGTATGGTCCGCTCTCA - 3'	6	58.8

TABLE 2-continued

<u>List of DNA sequences used for spatial encoding of antibodies</u>			
Sequence Name	Sequence	SEQ ID NO:	T _m (50 mM NaCl) ° C.
DD'	5' NH3-AAAAAAAAAATGAGAGCGGACCATACGATC-3'	7	58
EE	5'-AAAAAAAAAGCACTAACTGGTCTGGGTCA-3'	8	59.2
EE'	5' NH3-AAAAAAAAAATGACCCAGACCAGTTAGTGC-3'	9	58.4
FF	5'-AAAAAAAAAATGCCCTATTGTTGCGTCGGA-3'	10	60.1
FF'	5' NH3-AAAAAAAAAATCCGACGCAACAATAGGGCA-3'	11	60.1
GG	5'-AAAAAAAAAACTCTGTGAACTGTTCATCGGT-3'	12	57.8
GG'	5' NH3-AAAAAAAAAACCGATGACAGTTCACAGAG-3'	13	57
HH	5'-AAAAAAAAAAGAGTAGCCTTCCCGAGCATT-3'	14	59.3
HH'	5' NH3-AAAAAAAAAATGCTCGGGAAGGCTACTC-3'	15	58.6

* All amine-terminated strands were linked to antibodies to form DNA-antibody conjugates using SFB/SANH coupling chemistry as described by R. Bailey et al. Codes AA-HH were used in the experiment which examined fresh whole blood from a healthy volunteer. Codes A-M were used for the molecular analyses of cancer patient serum samples.

Example 4

Target Detection from a Single Whole Blood Sample

[0187] An exemplary separation-analysis procedure was performed as follows. A blood chip, composed of a blood separation microfluidic attached to a DNA array-spotted glass slide, was first encoded with three different human cytokine capture antibodies, forming an on-chip DEAL array. Sheep blood samples spiked with human cytokines were then delivered into the device. Separated plasma flowed over the array, and each cytokine target was captured on a different array spot.

[0188] The array was then developed for read-out by first selectively binding biotin-functionalized antibodies to surface-bound targets. Spots containing analyte could then be visualized by treatment with streptavidin-gold nanoparticles and gold amplification are illustrated in FIGS. 12 and 13.

[0189] FIGS. 12 and 13 show a representative microarray slide showing the simultaneous detection of three cytokine targets. The assay region is shown for two of the assay lanes on the chip.

[0190] In particular FIG. 13 shows the bright-field and dark-field image of two assay lanes of the array of FIG. 12 after gold amplification. Six DNA sequences (AF) were printed on the slide, but only three were encoded with capture antibodies (A-C). The concentrations of IFN- γ , TNF- α , IL-2 in blood were 500 pM, 1 nM, and 6 nM, respectively. Typically, the underlying array was exposed to analytes for 0.5-1 h

[0191] A similar separation and assay was performed using a microfluidic-patterned DEAL barcode array. In contrast to conventional spots, a high-density barcode pattern was used in FIG. 11. Six DNA sequences printed, as 20 cm-wide stripes, were present on the slide. Arrow indicates flow direction during the run. The concentrations of IFN- γ and TNF- α in blood were 500 pM and 1 nM, respectively. The plasma

was allowed to flow over the encoded stripes for 0.5 h. FIG. 11 shows a typical result for a slide developed by gold amplification. Both cytokine targets are clearly present in both the bright and dark field images.

Example 5

Blood Separation and Multiparameter Protein Assay Using Blood Separation/Protein Assay Chips Including DEAL Technology

[0192] The compatibility of the DEAL technique with integrated microfluidics yielded rapid blood separations and reliable measurements of a panel of proteins. The experimental procedure is detailed below.

[0193] a. Blocking: Prior to use of the BS/PA Chips, all microfluidic channels were blocked with the assay buffer solution (1% w/v BSA/PBS solution prepared by adding 98% pure Bovine Serum Albumin, Fraction V (Sigma) to 150 mM 1 \times PBS without calcium/magnesium salts (Irvine Scientific)) for 30-60 minutes.

[0194] b. DEAL formation (introducing conjugates): A solution containing all DNA-antibody conjugates was flowed through the assay channels of the BS/PA chips for ~30-45 min, and thus transformed the DNA barcode microarray into an antibody microarray, enabling the subsequent surface-bound immuno-assay. The unbound conjugates were removed by flowing the assay buffer solution for 10 minutes. The DEAL-conjugate solution was prepared by mixing all synthesized conjugates in 1% BSA/PBS with a final concentration of 5 μ g/mL. The DNA coding oligomers were pre-tested for orthogonality to ensure that cross-hybridization between non-complementary oligomer strands yielded a fluorescence intensity that did not exceed 5% of the complementary-pair signal intensity.

[0195] c. Collecting a finger-prick of blood: Finger pricks were carried out using BD Microtainer Contact-Activated

Lancets (purple lancet—for low volume, single blood drop). Blood was collected with SAFE-T-FILL capillary blood collection tubes (RAM Scientific), which we pre-filled with a 25 mM EDTA solution as discussed below. Two samples were prepared from the drop of whole blood.

[0196] (i) Unspiked Blood Samples: The blood collection tube was pre-filled with 80 μ L of 25 mM EDTA solution, and then 10 μ L of fresh human blood was collected in the EDTA-coated capillary, dispensed into the tube and rapidly mixed by inverting a few times.

[0197] (ii) Spiked Blood Samples: The blood collection tube was pre-filled with 40 μ L of 25 mM EDTA solution. Forty microliters of recombinant protein solution, containing all the protein standards, was added. Then, 2 μ L of 0.5 M EDTA was added to bring the total EDTA concentration up to 25 mM. Finally, 10 μ L of fresh human blood was collected in an EDTA-coated capillary, added to the tube and quickly mixed by inverting a few times. The final concentrations for all protein standards were on the order of 10 nM. However, the quality of these “standards” and the affinity of capture antibodies vary substantially. The purpose of spiking in protein standards was only to contrast the signal at high protein concentrations with that of as-collected fresh whole blood.

[0198] d. Blood sample assay: These two blood samples were flowed into the BS/PA chips within 1 minute of collection. The plasma was quickly separated from blood cells within the chip, and the proteins of interest were captured in the downstream assay zone containing the DEAL barcode arrays. The entire process from finger prick to the completion of plasma protein capture was very rapid (<10 mins), even though all steps were done by hand. Automated processes could expedite the entire process to <5 minutes. The short time scale for the assay is largely attributable to the reduced diffusion barrier in a flowing microfluidic environment. Conventional immunoassays take 1-2 hours or more—and they first require that the blood cells are separated by centrifugation.

[0199] e. Applying detection antibodies: A mixture of biotin-labeled detection antibodies was flowed into the microfluidic devices for ~30 min to complete the DEAL assay. The detection-antibody solution contained biotinylated detection antibodies at ~5 μ M prepared in 1% BSA/PBS. Afterwards, unbound detection antibodies in the BS/PA chips were removed by flowing the assay buffer for 10 minutes.

[0200] f. Fluorescence probes: Cy5 fluorescent dye-labeled streptavidin and the reference, Cy3-labeled complementary ssDNA (DNA code M/M'), were mixed together and were then flowed into the BS/PA chips for 30 min. Finally, the assay buffer was flowed for 10 minutes to remove unbound Streptavidin-Cy5.

[0201] g. Rinse: The PDMS blood chip device was removed from the DNA-patterned glass slide. The slide was immediately dipped 6 times each in the following solutions in order: 1% BSA/PBS solution, 1 \times PBS solution, 1/2 \times PBS solution, deionized Millipore H₂O. The slide was rinsed for a few seconds under a Millipore H₂O stream, and then dried with a nitrogen gun.

[0202] h. Optical readout: The slide was scanned by an Axon Instruments Genepix Scanner. The finest resolution (5 μ m) was selected. Two color channels (the green Cy3 channel and the red Cy5 channel) were turned on to collect fluorescence signals.

Example 6

Fabrication of a Barcoded Chip for Plasma Separation and from Whole Blood

[0203] The fabrication of the IBBCs was accomplished through a two-layer soft lithography approach. A representative chip design is shown in FIG. 7. The silicon master for the control layer (red) was fabricated by exposing a spin-coated SU8 2010 negative photoresist film (~20 micrometers in thickness). Prior to molding, the master was silanized in a trimethylchlorosilane (TMCS) vapor box for 20 min. A mixture of GE RTV 615 PDMS prepolymer part A and part B (5:1) was prepared, homogenized, and then applied onto the control layer master. After degassing for 15 min, the PDMS was cured at 80° C. for 50 min. Then the solidified PDMS chips were cut off the master and the access holes were drilled with a 23 gauge stainless-steel hole

[0204] FIG. 7 shows in particular an AutoCAD design of an IBBC: flow layer in red; control layer in green. Underneath the PDMS microfluidic chip is a large-scale DNA bar-code array.

[0205] The flow-layer master (blue) was fabricated using SPR 220 positive photoresistive. After exposure and development, the photoresist pattern was baked at 120° C. in a convection oven to round the flow channels. The resultant flow layer was typically 15-20 μ m in thickness. Silanization treatment using TMCS was performed right before applying the fluid PDMS prepolymer. Next, a mixture of GE RTV 615 PDMS part A and part B (20:1) was prepared, homogenized, degassed, and then spun onto the flow layer master at 2000-3000 rpm for 1 min. It was cured at 80° C. for 30 min, at which point the PDMS control layer was carefully aligned and placed onto the flow layer. Finally, an additional 60-min thermal treatment at 80° C. was performed to bond the two PDMS layers together. The bilayer chip was then carefully peeled off of the flow-layer master and access holes were drilled.

[0206] Finally, the PDMS chip was bonded to the DEAL barcode slide via thermal treatment at 80 C for 4 hours, yielding a completed integrated blood separation/protein assay (BS/PA) chip. In this chip, the DEAL barcode stripes are orientated perpendicular to the microfluidic assay channels. The BS/PA features a microfluidic biological fluid-handling module, specifically a whole blood separation unit, and a DEAL barcode array for highly multiplexed protein measurements. In a typical design, 8-12 identical blood separation and detection units were integrated on a single 2.5 cm \times 7 cm chip.

Example 7

Patterning of Barcode Arrays

[0207] Using a microchannel-guided flow-patterning approach, DEAL barcode arrays were fabricated. Although traditional inkjet spotting methods could also have been employed for spotting the DNA oligomers, the microchannel-guided flow-patterning approach permits for the formation of arrays that are at least an order of magnitude denser than conventional microarrays.

[0208] This was accomplished by creating a polydimethylsiloxane (PDMS) mold containing multiple parallel microfluidic channels, with each channel conveying a different biomolecule capture agent (FIG. 10). The number of channels could readily be expanded to include 100 or more different

capture agents. Poly-amine coated glass surfaces were utilized, as poly-amine permits significantly higher DNA loading (with associated higher final assay sensitivity) than do more traditional aminated surfaces. DNA “bars” of 20-micrometer (em) channel width were chosen so that they were compatible with a fluorescence microarray scanner for assay readout. That scanner had a resolution of 5 μm . The fabrication details are as follows.

[0209] a. Mold fabrication. The microfluidic-patterning chips were made by molding a PDMS elastomer from a master template, which was prepared using photolithography to create a photoresist pattern on a silicon wafer. Such methods are standard practice.

[0210] b. PDMS patterning chip fabrication. The polydimethylsiloxane (PDMS) elastomer molded in step 3a was then bonded onto a glass surface, which served as the channel floor. Prior to bonding, the glass surface was pre-coated with the polyamine polymer, poly-L-lysine (Sigma-Aldrich), to increase DNA loading. The coating process is described elsewhere. The number of microfluidic channels determines the size of the barcode array. In the present work, the PDMS chip, as shown in Fig S2a, contains 13 to 20 parallel microchannels that wind back and forth to cover a large area (3 cm \times 2 cm) of the glass slide with the DNA barcode microarray.

[0211] c. DEAL Barcode patterning. Solutions, each containing a different strand of primary DNA oligomers prepared in 1 \times PBS buffer, were flowed into each of the microfluidic channels. The solution-filled chip was then placed in a desiccator to allow solvent (water) to evaporate completely through the gas-permeable PDMS, leaving the DNA molecules behind. This process, which can be done days or months ahead of when the chips are actually used, can take several hours to complete. Lastly, the PDMS elastomer was removed from the glass slide, and the barcode-patterned DNA was fixed to the glass surface by thermal treatment at 80 C for 4 hours, or by UV crosslinking. It is noted that potassium phosphate crystals precipitated out during solution evaporation, but did not affect the quality of the DNA barcode arrays. These salts were readily removed by rapidly dipping the slide in deionized water prior to bonding the blood-assay chip to the slide.

[0212] The process is further shown in the schematic illustration of FIG. 10. (a) Schematic depiction of microchannel-guided patterning of the ssDNA barcode arrays. Each individual ssDNA bar was patterned to be 20 μm in width and to span the full dimensions of the glass substrate. (b) Integration of a DEAL barcode-patterned glass slide with the blood separation chip, to enable the detection multiple blood proteins. The plasma channels from the blood separation chip are aligned perpendicular to the long DEAL barcode patterns, so that multiple barcodes are incorporated into every narrow plasma channel. No further alignment is necessary. (c) Mask design of a 13-channel patterning chip. A-M denotes the channels for flowing the different ssDNA oligomers. (d) Validation of successful patterning of DNA molecules by specific hybridization of oligomer A to its fluorescent complementary strand A'. The primary strands B and C were pre-tagged with red and green dyes as references.

Example 8

Protein Analysis from Separated Plasma in Barcoded Chip

[0213] A barcoded chip including DEAL technology was used for the rapid measurement of a panel of serum biomar-

kers from a finger-prick of whole blood. In particular, rapid measurement of a panel of blood biomarkers from a finger-prick of whole blood for two cases—fresh whole blood spiked with proteins, and fresh whole blood. All critical steps for the protein assay, starting from the actual pricking of the finger, were accomplished in less than 10 minutes.

[0214] The results are shown in FIG. 15. In panel a. optical micrographs showing the effective separation of plasma from fresh whole blood are shown. A few red blood cells were occasionally detected exiting the plasma channels, but the plasma was >99.99% free from cells, and the few cells present did not affect the protein assay. In panel (b) Fluorescence image of the blood barcodes in two adjacent microchannels of an IBBC, on which both the unspiked and spiked fresh whole blood collected from a healthy volunteer were separately assayed. Eight plasma proteins are indicated. The bars are all 20 μm in width. Panel (c) shows fluorescence line profiles of the barcodes for both unspiked and spiked whole blood samples. The distance corresponds to the full length shown in b.

Example 9

Protein Analysis from Separated Plasma in Antibody-Coated Channel

Prophetic

[0215] The blood separation PDMS device is bonded directly to a plain glass slide or poly-L-lysine treated glass slide (that has not been pre-patterned). A 0.02 mg/mL solution of IL2 capture antibody (unconjugated to polynucleotide) is flowed into a single device and completely fills the volume of the device.

[0216] The solution incubates in the device at room temperature for 1 hr. 1 \times PBS wash solution is then flowed in to remove unbound antibody. 1% BSA/PBS is then flowed throughout the device for blocking 1 hr at RT. Blood spiked with 30 nM recombinant IL2 is then flowed into the device for 1 hr at RT, and plasma containing the spiked IL2 is separated from the whole blood and passes over the wide channel region. 1 \times PBS wash solution is flowed in for 10 minutes to remove unadhered biomolecules.

[0217] Biotinylated IL-2 detection antibody (0.02 mg/mL) in 1% BSA/PBS is then flowed in for 1 hr at RT followed by 1 \times PBS wash solution. Cy5-conjugated Streptavidin (0.02 mg/mL) is then flowed in for 1 hr at RT followed by 1 \times PBS wash solution for 10 minutes. The PDMS device is removed and the slide is rinsed with PBS, then DI-H₂O, Slide is scanned in a fluorescence scanner (genepix) and intensity is quantified.

Example 10

Protein Analysis from Separated Plasma in a Channel with No Capture Agents

Prophetic

[0218] The blood separation PDMS device is bonded directly to a plain glass slide or poly-L-lysine treated glass slide (that has not been pre-patterned). The device is primed by completely filling its entire volume with 1 \times PBS. Blood spiked with 30 nM recombinant IL2 is then flowed into the device for 1 hr at RT, and plasma containing the spiked IL2 is separated from the whole blood and passes over the wide channel region.

[0219] 1×PBS wash solution is flowed in for 10 minutes to remove unadhered biomolecules. 1% BSA/PBS is then flowed throughout the device for blocking 1 hr at RT. Biotinylated IL-2 detection antibody (0.02 mg/mL) in 1% BSA/PBS is then flowed in for 1 hr at RT followed by 1×PBS wash solution. Cy5-conjugated Streptavidin (0.02 mg/mL) is then flowed in for 1 hr at RT followed by 1×PBS wash solution for 10 minutes. The PDMS device is removed and the slide is rinsed with PBS, then DI-H₂O. Slide is scanned in a fluorescence scanner (genepix) and intensity is quantified.

[0220] The examples set forth above are provided to give those of ordinary skill in the art a complete disclosure and description of how to make and use the embodiments of the devices, systems and methods of the disclosure, and are not intended to limit the scope of what the inventors regard as their disclosure. Modifications of the above-described modes for carrying out the disclosure that are obvious to persons of skill in the art are intended to be within the scope of the following claims. All patents and publications mentioned in the specification are indicative of the levels of skill of those skilled in the art to which the disclosure pertains. All references cited in this disclosure are incorporated by reference to the same extent as if each reference had been incorporated by reference in its entirety individually.

[0221] The entire disclosure of each document cited (including patents, patent applications, journal articles, abstracts, laboratory manuals, books, or other disclosures) in the Background, Detailed Description, and Examples is hereby incorporated herein by reference. Further, the hard copy of the sequence listing submitted herewith and the corresponding computer readable form are both incorporated herein by reference in their entireties.

[0222] It is to be understood that the disclosures are not limited to particular compositions or biological systems, which can, of course, vary. It is also to be understood that the terminology used herein is for the purpose of describing particular embodiments only, and is not intended to be limiting. As used in this specification and the appended claims, the singular forms “a,” “an,” and “the” include plural referents unless the content clearly dictates otherwise. The term “plurality” includes two or more referents unless the content clearly dictates otherwise. Unless defined otherwise, all technical and scientific terms used herein have the same meaning as commonly understood by one of ordinary skill in the art to which the disclosure pertains. Although any methods and materials similar or equivalent to those described herein can be used in the practice for testing of the specific examples of appropriate materials and methods are described herein.

[0223] A number of embodiments of the disclosure have been described. Nevertheless, it will be understood that various modifications may be made without departing from the

spirit and scope of the present disclosure. Accordingly, other embodiments are within the scope of the following claims.

REFERENCES

- [0224] Yang, S., Undar, A. & Zahn, J. D. A microfluidic device for continuous, real time blood plasma separation. *Lab on a Chip* 6, 871-880 (2006).
- [0225] Svanes, K. & Zweifach, B. W. Variations in small blood vessel hematocrits produced in hypothermic rates by micro-occlusion. *Microvascular Research* 1, 210-220 (1968).
- [0226] Fung, Y. C. Stochastic flow in capillary blood vessels. *Microvasc. Res.* 5, 34-38 (1973).
- [0227] Zimmermann, M., Delamarche, E., Wolf, M. & Hunziker, P. Modeling and optimization of high-sensitivity, low-volume microfluidic-based surface immunoassays. *Biomedical Microdevices* 7, 99-110 (2005).
- [0228] Hsieh, S. Y., Chen, R. K., Pan, Y. H. & Lee, H. L. Systematical evaluation of the effects of sample collection procedures on low-molecular-weight serum/plasma proteome profiling. *Proteomics* 6, 3189-3198 (2006).
- [0229] Anderson, N. L. & Anderson, N. G. The human plasma proteome—History, character, and diagnostic prospects. *Molecular & Cellular Proteomics* 1, 845-867 (2002).
- [0230] Lathrop, J. T., Anderson, N. L., Anderson, N. G. & Hammond, D. J. Therapeutic potential of the plasma proteome. *Current Opinion in Molecular Therapeutics* 5, 250-257 (2003).
- [0231] Bailey, R. C., Kwong, G. A., Radu, C. G., Witte, O. N. & Heath, J. R. DNA-encoded antibody libraries: A unified platform for multiplexed cell sorting and detection of genes and proteins. *Journal of the American Chemical Society* 129, 1959-1967 (2007).
- [0232] Thuillier, G. & Malek, C. K. Development of a low cost hybrid Si/PDMS multi-layered pneumatic microvalve. *Microsystem Technologies-Micro-and Nanosystems-Information Storage and Processing Systems* 12, 180-185 (2005).
- [0233] Thorsen, T., Maerkl, S. J. & Quake, S. R. Microfluidic large-scale integration. *Science* 298, 580-584 (2002).
- [0234] Hong, J. W. & Quake, S. R. Integrated nanoliter systems. *Nature Biotechnology* 21, 1179-1183 (2003).
- [0235] Heath, J. R. & Davis, M. E. Nanotechnology and cancer. *Annual Review of Medicine* 59, 405 (2007).
- [0236] Gorelik, E. et al. Multiplexed immunobead-based cytokine profiling for early detection of ovarian cancer. *Cancer Epidemiology Biomarkers & Prevention* 14, 981-987 (2005).
- [0237] Pirrung, M. C. How to make a DNA chip. *Angewandte Chemie-International Edition* 41, 1277-4 (2002).
- [0238] Dandy, D. S., Wu, P. & Grainger, D. W. Array feature size influences nucleic acid surface capture in DNA microarrays. *Proceedings of the National Academy of Sciences of the United States of America* 104, 8223-8228 (2007).

19
APPENDIX A

The plasma skimming portion of the blood chip can be modeled as a resistor network (see **Figure A1** which will be described making also reference to the elements illustrated in application **Figures 1 to 15** and in particular **Figures 1-6**).

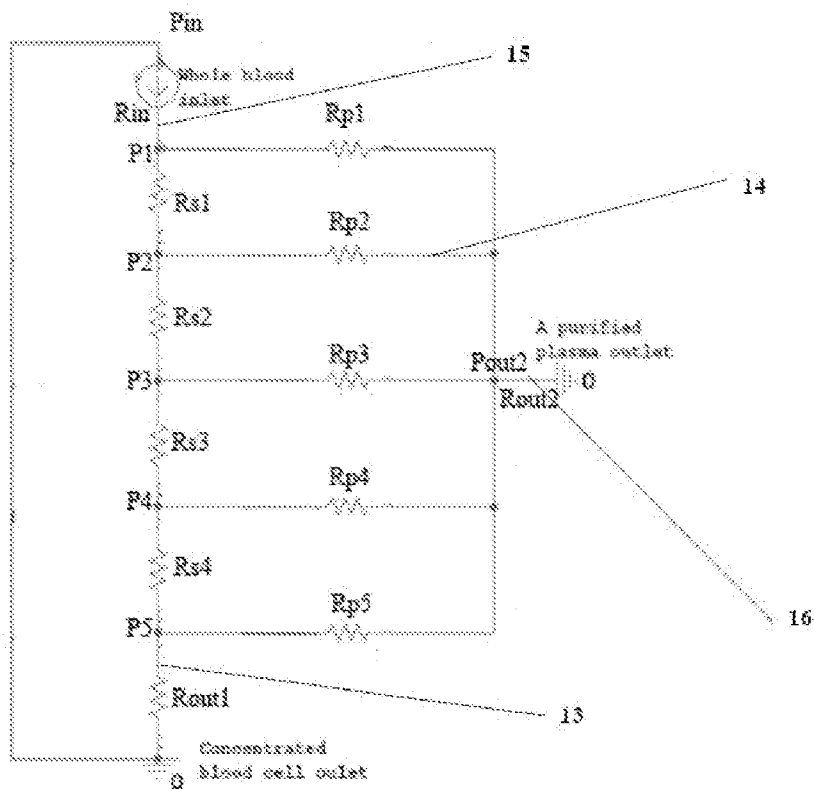

FIG. A1

The inlet pressure is given by P_{in} . Channel (15) of is divided into 5 sections that each have a given resistance. The boundaries of the 5 sections of channel (15) are as follows:

Section “in”: the section between the inlet and the first narrow channel has a resistance R_{in} and is associated with a flow rate Q_{in} . The pressure at the end of this segment is given by P_1 .

Segment s1. the section between the first narrow channel and the second narrow channel has a resistance R_{s1} and a flow rate Q_{s1} . The pressure at the end of this segment is given by P_2 .

Segment s2. the section between the second narrow channel and the third narrow channel has a resistance R_{s2} and a flow rate Q_{s2} . The pressure at the end of this segment is given by P_3 .

Segment s3. the section between the third narrow channel and the fourth narrow channel has a resistance R_{s3} and a flow rate Q_{s3} . The pressure at the end of this segment is given by P_4 .

Segment s4. the section between the fourth narrow channel and the fifth narrow channel has a resistance R_{s4} and a flow rate Q_{s4} . The pressure at the end of this segment is given by P_5 .

Channel (13) has a resistance R_{out1} and a flow rate Q_{out1} .

The narrow plasma channel (region 14) resistances and flow rates are given by the following:

Narrow Channel 1: R_{p1} , Q_{p1}

Narrow Channel 2: R_{p2} , Q_{p2}

Narrow Channel 3: R_{p3} , Q_{p3}

Narrow Channel 4: R_{p4} , Q_{p4}

Narrow Channel 5: R_{p5} , Q_{p5}

The wide plasma channel (region 16) resistance and flow rate is R_{out2} and Q_{out2} . The pressure at the junction between the narrow and wide plasma channels (junction between regions 14 and 16) is given by P_{out} .

Due to conservation of mass, the sum of the flow rates after a bifurcation in the circuit must equal the sum of the flow rates coming out of the bifurcation. For example, the inlet flow rate Q_{in} must equal the sum of the flow rates in the first narrow plasma channel (Q_{p1}) and in section 1 (Q_{s1}) of channel (15). Similarly, the

flow rate in section 1 (Q_{s1}) must equal the sum of Q_{p2} and R_{s2} , and so forth. Continuing in this fashion, Applicants obtain the following 6 equations.

1. $Q_{in} = Q_{p1} + Q_{s1}$
2. $Q_{s1} = Q_{p2} + Q_{s2}$
3. $Q_{s2} = Q_{p3} + Q_{s3}$
4. $Q_{s3} = Q_{p4} + Q_{s4}$
5. $Q_{s4} = Q_{p5} + Q_{out1}$
6. $Q_{out2} = Q_{p1} + Q_{p2} + Q_{p3} + Q_{p4} + Q_{p5}$

Next, Applicants note that segments $s1, s2, s3,$ and $s4$ all have the same dimensions and, therefore, the same resistances.

$$7a. R_{s1} = R_{s2} = R_{s3} = R_{s4} = R_s$$

In addition, the 5 narrow plasma channels also have the same dimensions and, therefore, the same resistances.

$$7b. R_{p1} = R_{p2} = R_{p3} = R_{p4} = R_p$$

Since the flows are being modeled by a resistor network, Applicants can substitute the electrical version of Ohm's law - $\Delta V = IR$ (V =voltage, I =current, R =resistance) - with the fluid flow version: $\Delta P = QR$ (P =pressure, Q =flow rate, R =flow resistance). Applicants apply this equation for every channel and segment in the diagram. So, for example, the pressure drop across the resistor R_{in} can be expressed as $P_{in} - P_1 = Q_{in}R_{in}$, and so forth. Applicants can write the following 12 equations.

8. $P_{in} - P_1 = Q_{in}R_{in}$
9. $P_1 - P_2 = Q_{s1}R_s$
10. $P_2 - P_3 = Q_{s2}R_s$
11. $P_{in} - P_1 = Q_{s3}R_s$
12. $P_{in} - P_1 = Q_{s4}R_s$
13. $P_1 - P_{out2} = Q_{p1}R_p$

$$14. P_2 - P_{out2} = Q_{p2}R_p$$

$$15. P_3 - P_{out2} = Q_{p3}R_p$$

$$16. P_4 - P_{out2} = Q_{p4}R_p$$

$$17. P_5 - P_{out2} = Q_{p5}R_p$$

$$18. P_5 = I_{out1}R_{out1}$$

$$19. P_{out2} = I_{out2}R_{out2}$$

Applicants can then re-write equations 8-19 as follows:

$$20. P_{in} = P_1 + Q_{in}R_{in}$$

$$21. P_1 = P_2 + Q_{s1}R_s$$

$$22. P_2 = P_3 + Q_{s2}R_s$$

$$23. P_3 = P_4 + Q_{s3}R_s$$

$$24. P_4 = P_5 + Q_{s4}R_s$$

$$25. P_1 = P_{out2} + Q_{p1}R_p$$

$$26. P_2 = P_{out2} + Q_{p2}R_p$$

$$27. P_3 = P_{out2} + Q_{p3}R_p$$

$$28. P_4 = P_{out2} + Q_{p4}R_p$$

$$29. P_5 = P_{out2} + Q_{p5}R_p$$

Substituting equation 29 into equation 24 gives equation 31. Equation 31 can then be substituted into equation 23 to obtain equation 32. Continuing in this fashion with serial substitutions into equations 22,21,and 20, the following list of equations can be obtained:

$$30. P_5 = P_{out2} + Q_{p5}R_p$$

$$31. P_4 = P_{out2} + Q_{p5}R_p + Q_{s4}R_s$$

$$32. P_3 = P_{out2} + Q_{p5}R_p + Q_{s4}R_s + Q_{s3}R_s$$

$$33. P_2 = P_{out2} + Q_{p5}R_p + Q_{s4}R_s + Q_{s3}R_s + Q_{s2}R_s$$

$$34. P_1 = P_{out2} + Q_{p5}R_p + Q_{s4}R_s + Q_{s3}R_s + Q_{s2}R_s + Q_{s1}R_s$$

$$35. P_{in} = P_{out2} + Q_{p5}R_p + Q_{s4}R_s + Q_{s3}R_s + Q_{s2}R_s + Q_{s1}R_s + Q_{in}R_{in}$$

In similar fashion, one can substitute equation 5 into equation 4 to obtain equation 42. Equation 42 can then be substituted into equation 3 to obtain equation 43, and so forth to obtain equations 44 and 45.

$$36. Q_{s4} = Q_{p5} + Q_{out1}$$

$$37. Q_{s3} = Q_{p4} + Q_{p5} + Q_{out1}$$

$$38. Q_{s2} = Q_{p3} + Q_{p4} + Q_{p5} + Q_{out1}$$

$$39. Q_{s1} = Q_{p2} + Q_{p3} + Q_{p4} + Q_{p5} + Q_{out1}$$

$$40. Q_{in} = Q_{p1} + Q_{p2} + Q_{p3} + Q_{p4} + Q_{p5} + Q_{out1}$$

Substituting equation 6 into equation 45, the following relation can be obtained:

$$41. Q_{in} = Q_{out2} + Q_{out1}$$

The following substitutions can then be made. Equation 36 can be substituted in for Q_{s4} in equations 31-35. Equation 37 can be substituted for Q_{s3} in equations 32-35. Substitute: 38 into 33-35; 39 into 34-35; 40 into 35. In so doing the following set of equations is obtained.

$$42. P_5 = P_{out2} + Q_{p5}R_p$$

$$43. P_4 = P_{out2} + Q_{p5}R_p + (Q_{p5} + Q_{out1})R_s$$

$$44. P_3 = P_{out2} + Q_{p5}R_p + (Q_{p5} + Q_{out1})R_s + (Q_{p4} + Q_{p5} + Q_{out1})R_s$$

$$45. P_2 = P_{out2} + Q_{p5}R_p + (Q_{p5} + Q_{out1})R_s + (Q_{p4} + Q_{p5} + Q_{out1})R_s + (Q_{p3} + Q_{p4} + Q_{p5} + Q_{out1})R_s$$

$$46. P_1 = P_{out2} + Q_{p5}R_p + (Q_{p5} + Q_{out1})R_s + (Q_{p4} + Q_{p5} + Q_{out1})R_s + (Q_{p3} + Q_{p4} + Q_{p5} + Q_{out1})R_s + (Q_{p2} + Q_{p3} + Q_{p4} + Q_{p5} + Q_{out1})R_s$$

$$47. P_{in} = P_{out2} + Q_{p5}R_p + (Q_{p5} + Q_{out1})R_s + (Q_{p4} + Q_{p5} + Q_{out1})R_s + (Q_{p3} + Q_{p4} + Q_{p5} + Q_{out1})R_s + (Q_{p2} + Q_{p3} + Q_{p4} + Q_{p5} + Q_{out1})R_s + Q_{in}R_{in}$$

Substituting equation 18 into 42 for the value of P_5 , Equation 28 into 43 for value of P_4 , and so forth for P_3 , P_2 , P_1 , the following equations are obtained:

$$48. Q_{out1}R_{out1} = P_{out2} + Q_{p5}R_p$$

$$49. P_{out2} + Q_{p4}R_p = P_{out2} + Q_{p5}R_p + (Q_{p5} + Q_{out1})R_s$$

$$50. P_{out2} + Q_{p3}R_p = P_{out2} + Q_{p5}R_p + (Q_{p5} + Q_{out1})R_s + (Q_{p4} + Q_{p5} + Q_{out1})R_s$$

$$51. P_{out2} + Q_{p2}R_p = P_{out2} + Q_{p5}R_p + (Q_{p5} + Q_{out1})R_s + (Q_{p4} + Q_{p5} + Q_{out1})R_s + (Q_{p3} + Q_{p4} + Q_{p5} + Q_{out1})R_s$$

$$52. P_{out2} + Q_{p1}R_p = P_{out2} + Q_{p5}R_p + (Q_{p5} + Q_{out1})R_s + (Q_{p4} + Q_{p5} + Q_{out1})R_s + (Q_{p3} + Q_{p4} + Q_{p5} + Q_{out1})R_s + (Q_{p2} + Q_{p3} + Q_{p4} + Q_{p5} + Q_{out1})R_s$$

$$53. P_{in} = P_{out2} + Q_{p5}R_p + (Q_{p5} + Q_{out1})R_s + (Q_{p4} + Q_{p5} + Q_{out1})R_s + (Q_{p3} + Q_{p4} + Q_{p5} + Q_{out1})R_s + (Q_{p2} + Q_{p3} + Q_{p4} + Q_{p5} + Q_{out1})R_s + (Q_{p1} + Q_{p2} + Q_{p3} + Q_{p4} + Q_{p5} + Q_{out1})R_{in}$$

The variable P_{out2} cancels from both sides in equations 49-52, giving us Eqs. 55-58 below. In addition, one can substitute Eq.19 into Eqs. 48 and 53 to obtain the following equations after simplification:

$$54. Q_{out1}R_{out1} = Q_{out2}R_{out2} + Q_{p5}R_p$$

$$55. Q_{p4}R_p = Q_{p5}R_p + (Q_{p5} + Q_{out1})R_s$$

$$56. Q_{p3}R_p = Q_{p5}R_p + (Q_{p5} + Q_{out1})R_s + (Q_{p4} + Q_{p5} + Q_{out1})R_s$$

$$57. Q_{p2}R_p = Q_{p5}R_p + (Q_{p5} + Q_{out1})R_s + (Q_{p4} + Q_{p5} + Q_{out1})R_s + (Q_{p3} + Q_{p4} + Q_{p5} + Q_{out1})R_s$$

$$58. Q_{p1}R_p = Q_{p5}R_p + (Q_{p5} + Q_{out1})R_s + (Q_{p4} + Q_{p5} + Q_{out1})R_s + (Q_{p3} + Q_{p4} + Q_{p5} + Q_{out1})R_s + (Q_{p2} + Q_{p3} + Q_{p4} + Q_{p5} + Q_{out1})R_s$$

$$59. P_{in} = Q_{out2}R_{out2} + Q_{p5}R_p + (Q_{p5} + Q_{out1})R_s + (Q_{p4} + Q_{p5} + Q_{out1})R_s + (Q_{p3} + Q_{p4} + Q_{p5} + Q_{out1})R_s + (Q_{p2} + Q_{p3} + Q_{p4} + Q_{p5} + Q_{out1})R_s + (Q_{p1} + Q_{p2} + Q_{p3} + Q_{p4} + Q_{p5} + Q_{out1})R_{in}$$

Substituting Eq. 6 into Eqs. 48 and 53 for Q_{out2} , one can obtain, after simplification and re-arrangement, equations 60 and 65 below. In addition one can re-arrange equations 55-58 to obtain equations 61-64 below.

$$60. 0 = Q_{out1}R_{out1} - Q_{p5}(R_p + R_{out2}) - Q_{p4}R_{out2} - Q_{p3}R_{out2} - Q_{p2}R_{out2} - Q_{p1}R_{out2}$$

$$61. 0 = Q_{out1}(R_s) + Q_{p5}(R_p + R_s) + - Q_{p4}(R_p)$$

$$62. 0 = Q_{out1}(2R_s) + Q_{p5}(R_p + 2R_s) + Q_{p4}(R_s) - Q_{p3}(R_p)$$

$$63. 0 = Q_{out1}(3R_s) + Q_{p5}(R_p + 3R_s) + Q_{p4}(2R_s) + Q_{p3}(R_s) - Q_{p2}(R_p)$$

$$64. 0 = Q_{out1}(4R_s) + Q_{p5}(R_p + 4R_s) + Q_{p4}(3R_s) + Q_{p3}(2R_s) + Q_{p2}(R_s) - Q_{p1}(R_p)$$

$$65. P_{in} = Q_{p5}(R_p+4R_s+R_{in}+R_{out2}) + Q_{out1}(4R_s+R_{in}) + Q_{p4}(3R_s+R_{in}+R_{out2}) + Q_{p3}(2R_s+R_{in}+R_{out2}) + Q_{p2}(R_s+R_{in}+R_{out2}) + Q_{p1}(R_{in}+R_{out2})$$

The set of Eqs. 60-65 can be re-written in matrix notation in the form:

71. $P=RQ$, where P, R, and Q are the pressure, flow resistance, and flow rate matrices respectively, as follows:

R=

$$\begin{bmatrix} [R_{out1} & -R_p - R_{out2} & -R_{out2} & -R_{out2} & -R_{out2} & -R_{out2}] \\ [R_s & R_p+R_s & -R_p & 0 & 0 & 0] \\ [2R_s & R_p+2R_s & R_s & -R_p & 0 & 0] \\ [3R_s & R_p+3R_s & 2R_s & R_s & -R_p & 0] \\ [4R_s & R_p+4R_s & 3R_s & 2R_s & R_s & -R_p] \\ [4R_s+R_{in} & R_p+4R_s+R_{in}+R_{out2} & 3R_s+R_{in}+R_{out2} & 2R_s+R_{in}+R_{out2} & R_s+R_{in}+R_{out2} & R_{in}+R_{out2}] \end{bmatrix}$$

$$Q = \begin{bmatrix} [Q_{out1}] \\ [Q_{p5}] \\ [Q_{p4}] \\ [Q_{p3}] \\ [Q_{p2}] \\ [Q_{p1}] \end{bmatrix} \quad P = \begin{bmatrix} [0] \\ [0] \\ [0] \\ [0] \\ [0] \\ [P_{in}] \end{bmatrix}$$

The value of each of the resistances in the above matrix R is determined by the dimensions of the associated channel, according to the equation:

$$R = \frac{12\mu L}{wh^3} \left[1 - \frac{h}{w} \left(\frac{192}{\pi^5} \sum_{n=1,3,5}^{\infty} \frac{1}{n^5} \tanh\left(\frac{n\pi w}{2h}\right) \right) \right]^{-1}$$

where R is the channel resistance; L, w, and h are the channel length, width, and height respectively; μ is the fluid viscosity; and n is the number of terms needed before the value converges at about 4 decimal places. The user inputs the dimensions

of each channel (L,w,h) and the viscosity of the fluid (in this case blood) and the program outputs the resistances for all the channels into the above resistance matrix.

The flow rate matrix Q can be solved by matrix multiplication of the inverse resistance matrix R^{-1} with the pressure matrix P (using Matlab). The user inputs the desired pressure P_{in} .

$$72. Q = R^{-1}P$$

This gives the flow rates $Q_{out1}, Q_{p5}, Q_{p4}, Q_{p3}, Q_{p2}, Q_{p1}$. These values can be plugged into Eqs. 1-6 to obtain the values of $Q_{s1}, Q_{s2}, Q_{s3}, Q_{s4}$, and Q_{out2} . The program then takes the flow ratio of each narrow plasma channel over the channel 15 segment downstream of it, as follows:

$$73. Q_{p1}:Q_{s1}$$

$$74. Q_{p2}:Q_{s2}$$

$$75. Q_{p3}:Q_{s3}$$

$$76. Q_{p4}:Q_{s4}$$

$$77. Q_{p5}:Q_{out1}$$

The program can calculate the yield of plasma from whole blood by dividing the wide plasma channel flow rate Q_{out2} by the flow rate of whole blood going out channel 13 and multiplying that value by 100, as follows:

$$78. \%yield = (Q_{out2}/Q_{out1}) \times 100$$

The program can also find the velocity (v) of fluid moving through any channel by dividing the flow rate of the channel (Q) by the cross-sectional area (A) of the channel, as follows:

$$78. v = Q/A$$

It has been observed empirically that plasma skimmed by the narrow plasma channels (region 14) has very few cells when the flow ratios in 73-77 above are >20:1.

In addition, yields above 5% were selected and flow velocities in the plasma channel that are at least 0.5mm/sec (affinity limited regime) for fast assays. The user can modify the pressure P_{in} until the desired flow velocity (>0.5 mm/sec) in Eq. 78 is obtained. The upper limit on P_{in} is usually about 25-30 psi for PDMS bonded to glass.

Applicants input dimensions into the Matlab program for each of the channels and run the program to identify flow ratios, yield, and velocities. According to the experimental design of choice the selected dimensions are as follows.

The height of all the channels is usually kept constant $h=10$ um (but can be adjusted up to 20um).

The width of the narrow plasma channels is usually kept constant at $w=10$ um, but can be varied from 5-20 um.

The length of the narrow plasma channels can vary from 1 mm-100 mm, but usually is within the range of about 10-25mm.

The length of channel (15) can be varied from 50 um to 1000 um.

The width of channel (15) can be varied from 10 um to 45 um. 25-35 um is ideal for reducing clogging while maintaining separation efficiency.

Channel (13)'s length can be from 0.5mm-20mm. Generally, Applicants stayed in the range of about 5-10mm.

Channel (13)'s width can be varied from 40 um to 500 um. Generally, Applicants picked values in the range of about 80-150 um.

Channel (16) is intended to have a length of about 1-30mm, but usually in the range of 5-10mm.

Channel (16) is intended to be about 10-100 times wider than the sum of channel widths in region (14). As a result, the channel resistance is very small and does not affect the separation efficiency very much. Another consequence is that the flow velocity through this channel is 10-100 times slower. Therefore, if the input pressure or the channel (14) dimensions are adjusted to obtain a velocity of about 0.5mm/sec (affinity limited process), the flow velocity in channel (16) will be about 0.05-0.005mm/sec (diffusion-limited process).

The flow ratios (Eq. 73-77) needed to obtain a good separation scale inversely with the radius of the particle. For example, the radius of a typical red blood cell is

about 5-10 μ m and the related flow ratio threshold for good separation is $>20:1$. If the particles in the fluid being separated have twice the diameter (10-20 μ m), the threshold flow ratio for good separation becomes $>10:1$. Conversely, if the particles have half the diameter (2.5-5 μ m) the threshold for good separation becomes $>40:1$, and so forth.

All channels have the same height, narrow plasma channels have the same width, and channel (15)'S width is usually about 25-35 μ m. Ordinarily, just the narrow plasma channel lengths and the width of channel (13) are varied to simplify the process of choosing channel dimensions. The program is run and values of flow ratios, yield, and narrow channel velocity are obtained. For example, let's say the program outputs the following:

Flow ratios- 20:1 (threshold flow ratio)

Yield – 20% ($>5\%$)

Flow velocity-0.2mm/sec (>0.5 mm/sec needed for affinity limited process).

The flow ratio meets the predetermined threshold of 20:1 but the fact that the yield is 20% means that the flow rate ration can be increased to obtain a better separation, without going below the predetermined limit of 5% yield. To increase the flow ratio, a user can increase the length of the narrow plasma channels or increase the width of channel (13). Increasing the length of region (14) channels will increase their resistance and slow down flow rate and flow velocity (which is already below our threshold). But then a user can just increase the inlet pressure (P_{in}) value in the program to obtain a faster flow velocity through those channels.

One continues to iterate this process of changing channel (14) lengths and channel (13) widths (and occasionally other channels' dimensions) and inlet pressure P_{in} until flow ratios $>20:1$, yields $>5\%$, and narrow channel flow velocities >0.5 mm/sec are obtained.

Applicants then set the width of channel (16) so that it will be <0.05 mm/sec needed for diffusion-limited flow in our system. For example, a possible scenario is that through iterations of running the program with different channel dimensions, Applicants found an optimization in which the flow velocity is exactly 0.5mm/sec

(affinity limited) in the narrow plasma channels. In this scenario, if Applicants want channel (16) to have a flow velocity of 0.05mm/sec (beginning of diffusion-limited flow regime), Applicants need to design channel (16) with 10 times the combined widths of the narrow plasma channels (in region 14). This is because given the same flow rate (since the regions are connected in series), the velocity will be inversely proportional to the width of the channels. A 10-fold increase in channel width will amount to a 10 fold decrease in flow velocity. More likely, a 100 times increase in channel width (for channel 16) will place the device settings more firmly in the diffusion-limited regime ($<0.005\text{mm/sec}$). In an exemplary embodiment illustrated herein, the narrow plasma channels are each 10um wide and there are 5 of them for a combined width of 50um. To obtain a 10-times slower flow velocity in the wide plasma channel, Applicants have set the width 10 times greater (at 500um).

In a different system with different antibody binding constants and different concentrations, different velocities will be obtained for affinity limited and diffusion limited flow (according to the 4 equations shown before from the Zimmermann paper). These velocities should be calculated in advance so that the relative ratios of channel (14) and channel (16) widths can be determined. For an n -fold difference between calculated affinity-limited and diffusion-limited velocities (based on the equations of the Zimmermann model), the wide plasma channel should be designed n times wider than the narrow plasma channels.

* * *

SEQUENCE LISTING

<160> NUMBER OF SEQ ID NOS: 15

<210> SEQ ID NO 1
<211> LENGTH: 30
<212> TYPE: DNA
<213> ORGANISM: artificial sequence
<220> FEATURE:
<223> OTHER INFORMATION: Synthetic polynucleotide

<400> SEQUENCE: 1

aaaaaaaaa gtcacagact agccacgaag 30

<210> SEQ ID NO 2
<211> LENGTH: 30
<212> TYPE: DNA
<213> ORGANISM: artificial sequence
<220> FEATURE:
<223> OTHER INFORMATION: Synthetic Oligonucleotide

<400> SEQUENCE: 2

aaaaaaaaa gcgtgtgtgg actctctcta 30

<210> SEQ ID NO 3
<211> LENGTH: 30
<212> TYPE: DNA
<213> ORGANISM: artificial sequence
<220> FEATURE:
<223> OTHER INFORMATION: Synthetic Oligonucleotide

<400> SEQUENCE: 3

aaaaaaaaa tagagagagt ccacacagc 30

<210> SEQ ID NO 4
<211> LENGTH: 30
<212> TYPE: DNA
<213> ORGANISM: artificial sequence
<220> FEATURE:
<223> OTHER INFORMATION: Synthetic Oligonucleotide

<400> SEQUENCE: 4

aaaaaaaaa tcttctagtt gtcgagcagg 30

<210> SEQ ID NO 5
<211> LENGTH: 30
<212> TYPE: DNA
<213> ORGANISM: artificial sequence
<220> FEATURE:
<223> OTHER INFORMATION: Synthetic Oligonucleotide

<400> SEQUENCE: 5

aaaaaaaaa cctgctcgac aactagaaga 30

<210> SEQ ID NO 6
<211> LENGTH: 30
<212> TYPE: DNA
<213> ORGANISM: artificial sequence
<220> FEATURE:
<223> OTHER INFORMATION: Synthetic Oligonucleotide

<400> SEQUENCE: 6

aaaaaaaaa gatcgtatgg tccgctctca 30

-continued

<210> SEQ ID NO 7
<211> LENGTH: 30
<212> TYPE: DNA
<213> ORGANISM: artificial sequence
<220> FEATURE:
<223> OTHER INFORMATION: Synthetic Oligonucleotide

<400> SEQUENCE: 7
aaaaaaaaa tgagagcgga ccatagatc 30

<210> SEQ ID NO 8
<211> LENGTH: 30
<212> TYPE: DNA
<213> ORGANISM: artificial sequence
<220> FEATURE:
<223> OTHER INFORMATION: Synthetic Oligonucleotide

<400> SEQUENCE: 8
aaaaaaaaa gcactaactg gtctgggtca 30

<210> SEQ ID NO 9
<211> LENGTH: 30
<212> TYPE: DNA
<213> ORGANISM: artificial sequence
<220> FEATURE:
<223> OTHER INFORMATION: Synthetic Oligonucleotide

<400> SEQUENCE: 9
aaaaaaaaa tgaccagac cagttagtgc 30

<210> SEQ ID NO 10
<211> LENGTH: 30
<212> TYPE: DNA
<213> ORGANISM: artificial sequence
<220> FEATURE:
<223> OTHER INFORMATION: Synthetic Oligonucleotide

<400> SEQUENCE: 10
aaaaaaaaa tgcctattg ttgcgtcgga 30

<210> SEQ ID NO 11
<211> LENGTH: 30
<212> TYPE: DNA
<213> ORGANISM: artificial sequence
<220> FEATURE:
<223> OTHER INFORMATION: Synthetic Oligonucleotide

<400> SEQUENCE: 11
aaaaaaaaa tccgacgcaa caataggca 30

<210> SEQ ID NO 12
<211> LENGTH: 30
<212> TYPE: DNA
<213> ORGANISM: artificial sequence
<220> FEATURE:
<223> OTHER INFORMATION: Synthetic Oligonucleotide

<400> SEQUENCE: 12
aaaaaaaaa ctctgtgaac tgtcatcggt 30

<210> SEQ ID NO 13
<211> LENGTH: 30
<212> TYPE: DNA

-continued

```

<213> ORGANISM: artificial sequence
<220> FEATURE:
<223> OTHER INFORMATION: Synthetic Oligonucleotide

<400> SEQUENCE: 13

aaaaaaaaa accgatgaca gttcacagag                               30

<210> SEQ ID NO 14
<211> LENGTH: 30
<212> TYPE: DNA
<213> ORGANISM: artificial sequence
<220> FEATURE:
<223> OTHER INFORMATION: Synthetic Oligonucleotide

<400> SEQUENCE: 14

aaaaaaaaa gagtagcctt cccgagcatt                               30

<210> SEQ ID NO 15
<211> LENGTH: 30
<212> TYPE: DNA
<213> ORGANISM: artificial sequence
<220> FEATURE:
<223> OTHER INFORMATION: Synthetic Oligonucleotide

<400> SEQUENCE: 15

aaaaaaaaa aatgctcggg aaggctactc                               30

```

What is claimed is:

1. A microfluidic device for detecting at least one target in a fluidic component of a fluid sample, the microfluidic device comprising:

- an inlet for introducing the fluid sample in the microfluidic device,
- a flowing channel in fluidic communication with the inlet, the flowing channel having a flowing channel resistance, and
- an assaying channel in fluidic communication with the flowing channel, the assaying channel having an assaying channel resistance and carrying at least one capture agent or component thereof, the at least one capture agent or component thereof attached to the assaying channel, the at least one capture agent having a binding affinity for the target,

wherein

the flowing channel resistance and the assaying channel resistance are adapted to control flowing of the fluidic component from the flowing channel to the assaying channel, and

the assaying channel resistance is further adapted to allow binding of the target to the capture agent to form a detectable target capture agent binding complex, said binding controlled by at least one between said binding affinity and diffusion of said target in the fluidic component.

2. The microfluidic device of claim **1**, wherein the flowing channel resistance and the assaying channel resistance are adapted to maximize flowing of the fluidic component from the flowing channel to the assaying channel.

3. The microfluidic device of claim **1**, wherein the assaying channel comprises a first portion wherein the binding is controlled by said binding affinity and a second portion wherein

the binding is controlled by said diffusion of said target molecule in the fluidic component.

4. The microfluidic device of claim **1**, wherein the fluid is blood and the fluidic component is plasma.

5. The microfluidic device of claim **1**, wherein the at least one capture agent or component thereof comprises a substrate polynucleotide attached to the assaying channel.

6. The microfluidic device of claim **5**, wherein the at least capture agent or component thereof further comprises

- a polynucleotide-encoded protein comprising a protein and an encoding polynucleotide attached to the protein, wherein the protein specifically binds the at least one target and the encoding polynucleotide is specifically bound to the substrate polynucleotide.

7. The microfluidic device of claim **1**, wherein the at least one target comprises a plurality of targets and the at least one capture agent or component thereof comprises:

- a plurality of substrate polynucleotides attached to the assaying channel, each polynucleotide of the plurality of substrate polynucleotides being sequence specific and positionally distinguishable from another.

8. The microfluidic device of claim **7**, wherein the plurality of capture agents or component thereof comprise

- a plurality of polynucleotide-encoded proteins, each polynucleotide-encoded protein comprising a protein and an encoding polynucleotide attached to the protein, wherein the protein specifically binds to a predetermined target of the plurality of targets and the encoding polynucleotide specifically binds to a sequence-specific and positionally distinguishable polynucleotide of the plurality of polynucleotides attached to the assaying channel, each protein and encoding polynucleotide being bindingly distinguishable from another.

9. The microfluidic device of claim 1, wherein the at least one capture agent or component thereof comprises a plurality of capture agents or component thereof, each of the plurality of capture agents bindingly distinguishable and positionally distinguishable from another, each of the plurality of capture agents specifically binding the target molecule in a capture agent target binding complex, and the plurality of capture agents are arranged on the assaying channel so that capture agent target binding complexes are detectable along substantially parallel lines forming a bar coded pattern.
10. A system for detecting at least one target in a fluidic component of a fluid sample, the system comprising the microfluidic device of claim 5 and a polynucleotide-encoded protein comprising a protein and an encoding polynucleotide attached to the protein, wherein the protein specifically binds a target and the encoding-polynucleotide specifically binds the substrate polynucleotide.
11. A system for detecting at least one target in a fluidic component of a fluid sample, the system comprising the microfluidic device of claim 7 and a plurality of polynucleotide-encoded proteins, each polynucleotide-encoded protein comprising a protein and an encoding polynucleotide attached to the protein, wherein the protein specifically binds to a predetermined target of the plurality of targets and the encoding polynucleotide specifically binds to a sequence-specific and positionally distinguishable polynucleotide of the plurality of polynucleotides attached to the assaying channel, each protein and encoding polynucleotide being bindingly distinguishable from another.
12. A method for detecting at least one target molecule in a fluidic component of a fluid sample, the method comprising: providing the fluid sample in a flowing microfluidic channel; controlling selective flowing of the fluidic component from the flowing microfluidic channel to an assaying microfluidic channel, the assaying microfluidic channel carrying at least one capture agent or a component thereof, the at least one capture agent attached to the assaying channel, the at least one capture agent having a binding affinity for the target molecule; contacting the at least one target molecule with the at least one capture agent in the assaying microfluidic channel for a time and under conditions to allow binding of the at least one target molecule to the at least one capture agent to form a detectable target capture agent binding complex, said binding controlled by said binding affinity or by diffusion of said target molecule in the fluidic component; and detecting the detectable target capture agent binding complex.
13. A microfluidic device for detecting at least one target in a fluidic component of a fluid sample, the microfluidic device comprising: an inlet for introducing the fluid sample in the microfluidic device, a flowing channel in fluidic communication with the inlet, the flowing channel having a flowing channel resistance, and an assaying channel in fluidic communication with the flowing channel, the assaying channel having an assaying channel resistance, wherein the flowing channel resistance and the assaying channel resistance are configured to control flowing of the fluidic component from the flowing channel to the assaying channel, and the assaying channel resistance is further configured to allow attachment of a target on a surface of said assaying channel, the attached target being detectable through labeled molecules specifically binding said target.

* * * * *