

J. F. HANIGAN.

REPLACING FROG FOR CARS OR LOCOMOTIVES.

(Application filed July 10, 1901.)

(No Model.)

2 Sheets—Sheet 1.

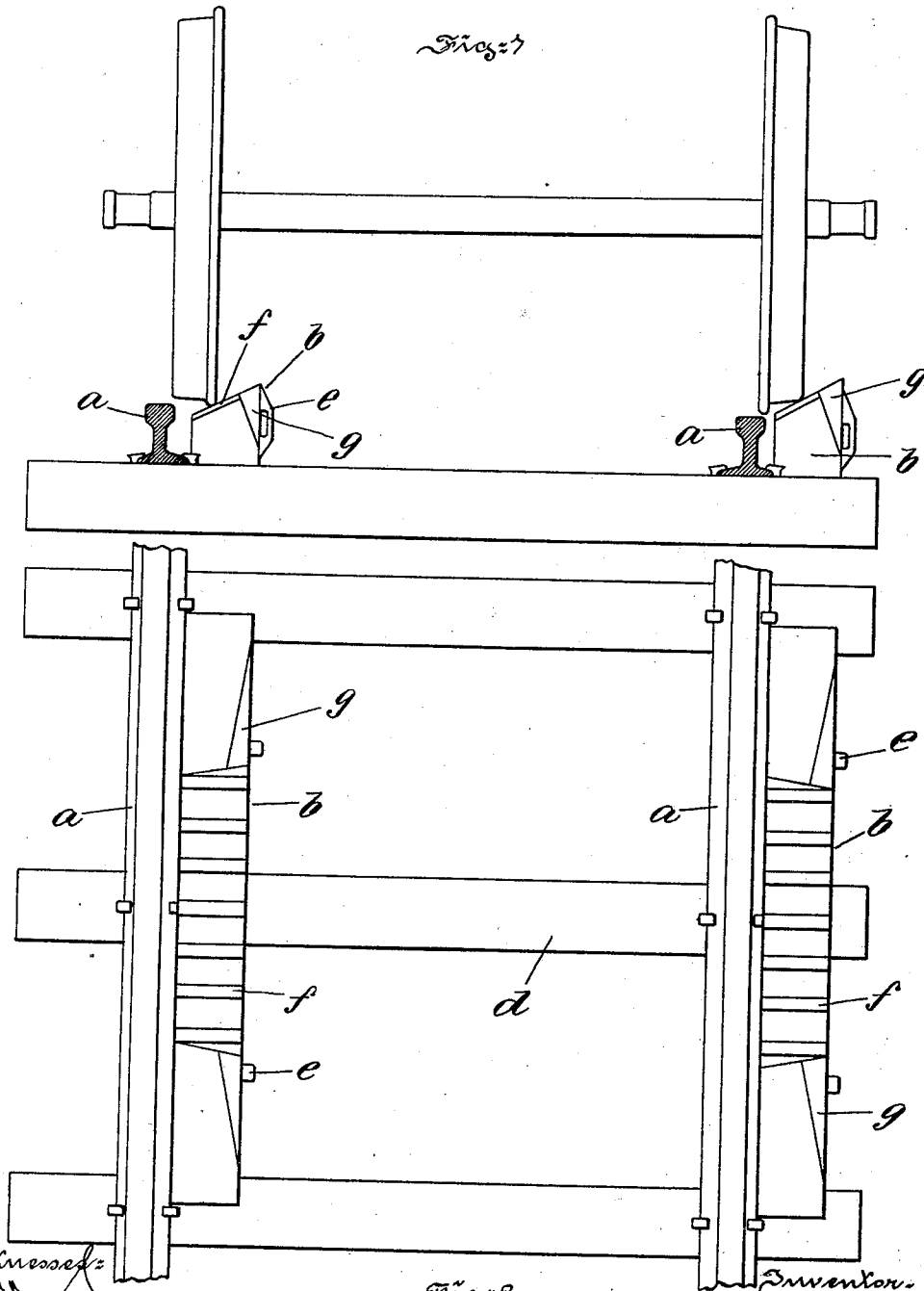

Fig. 1

Fig. 2

Prepared by  
 Frank H. Liedtke

Inventor  
 J. F. Hanigan.  
 By Paul V. Conolly,  
 Attorney.

J. F. HANIGAN.  
REPLACING FROG FOR CARS OR LOCOMOTIVES.

(Application filed July 10, 1901.)

(No Model.)

2 Sheets—Sheet 2.

Fig. 3

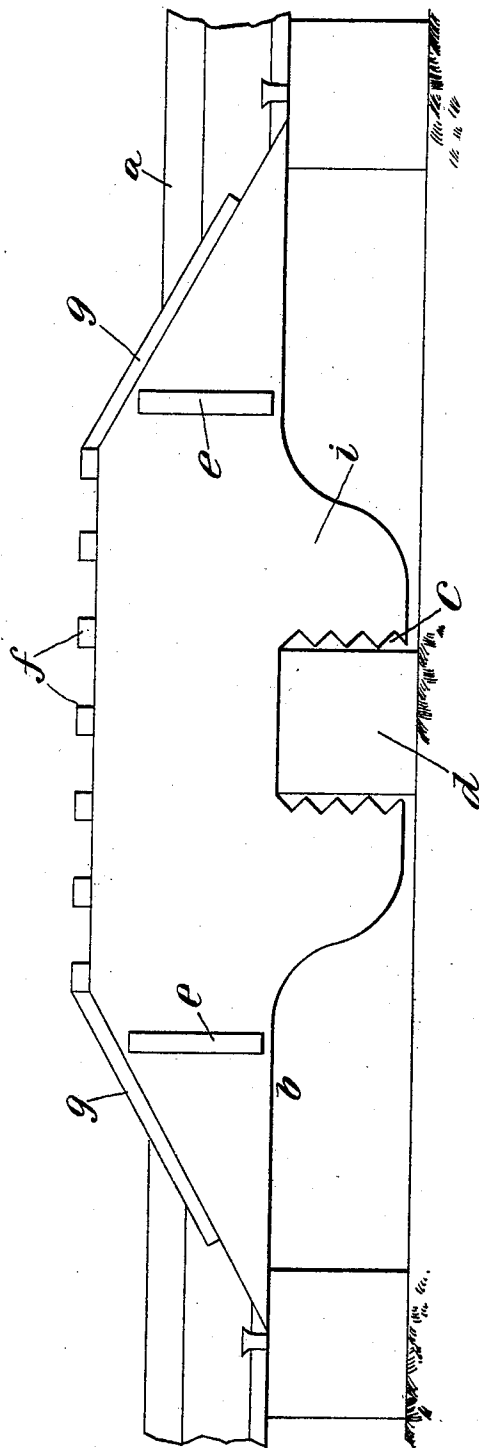

*Witnesses:*  
*W. H. ...*  
*Chas. H. ...*

*Inventor:*  
*J. F. Hanigan*  
*Paul V. Donnelly*  
*Attorney*

# UNITED STATES PATENT OFFICE.

JOHN F. HANIGAN, OF PHILADELPHIA, PENNSYLVANIA.

## REPLACING-FROG FOR CARS OR LOCOMOTIVES.

SPECIFICATION forming part of Letters Patent No. 683,041, dated September 24, 1901.

Application filed July 10, 1901. Serial No. 67,751. (No model.)

*To all whom it may concern:*

Be it known that I, JOHN F. HANIGAN, a citizen of the United States, residing at the city of Philadelphia, in the county of Philadelphia and State of Pennsylvania, have invented certain new and useful Improvements in Replacing - Frogs for Cars or Locomotives, of which the following is a specification, reference being had to the accompanying drawings, forming part hereof.

Generally speaking, the invention relates to that class of portable frogs employed in replacing derailed cars, locomotives, and other similar rolling-stock.

The principal object of the present invention is to perfect the existing type of frog.

A further object is to insure the frog against accidental displacement without the use of clamping devices.

A still further object is to provide means for more conveniently carrying and handling the frogs.

To these and other ends the invention consists of the improvements hereinafter described, and pointed out in the claims.

The nature, characteristic features, and scope of the invention will be more fully understood from the following description, taken in connection with the accompanying drawings, forming part hereof, and in which—

Figure 1 is a transverse elevational view, partly in section, illustrating the present invention in application to a railroad-track. Fig. 2 is a plan view of Fig. 1, and Fig. 3 is a side elevational view drawn to an enlarged scale.

Referring to the drawings, *a* represents the rails of a railway-track.

*b* represents the portable replacing-frogs, and, as shown in the drawings, span three railway ties or sleepers. While the number may be increased without harming the scope of the invention, the principal feature lies in the fact that by having the frog span at least three all use of clamping devices is obviated.

With reference more particularly to Figs. 2 and 3 the body portion is provided with a serrated portion *c*, which is adapted to fit over a tie or sleeper, as *d*. In this manner the frog is held against accidental displacement.

*e* represents handles by which the frogs may

be more readily removed and replaced as occasion demands.

It has been demonstrated that the crest of the frog is subjected to much wear and tear, and to compensate for this and in order to permit of the so-called "rolling-stock" being more readily shifted onto the track use is made of the strips *f*.

*g* represents guides adapted by reason of their shape and inclination to guide the rolling stock more readily onto the tracks.

As will be readily seen in the drawings, the crest of the frog is flat in contradistinction to curved, and the ends of the frog are inclined.

In practice when a car or locomotive is to be replaced the frogs are simply carried to the spot, and the portion *c* is simply placed over a tie or sleeper, and without the use of clamps and other disadvantageous features the frogs are securely held against accidental displacement. The wheels of the car or locomotive are then brought to the position indicated in Fig. 1, whereupon they are permitted to slide onto the track. By glancing at the left-hand end of the said figure it is noticed that a space is left between the frog and the rail, which affords room for the flanges of the wheel.

The described construction and operation of the present invention affords a convenient and desirable means for attaching frogs to rails that are practically inaccessible to frogs requiring considerable manipulation in order to secure them in proper position. Moreover, the frog is strengthened by the portion *i*, which accommodates the serrated portion *c*.

It will be obvious to those skilled in the art to which the invention appertains that modifications may be made in detail without departing from the spirit thereof. Hence I wish it understood that I do not limit myself to the precise construction and arrangement of the parts herein set forth; but,

Having thus described the nature and objects of the invention, what I claim, and desire to secure by Letters Patent, is—

1. A device of the character indicated comprising an enlarged body portion cut away to accommodate a railroad tie or sleeper and adapted to span at least three of said ties or sleepers, substantially as described.

2. A device of the character indicated, comprising a body portion having a flat crest and inclined portions leading thereto, guides mounted upon said inclined portions and strips upon the crest of the frog, substantially as described.

3. In combination a replacing-frog comprising an enlarged body portion adapted to span three or more railroad ties or sleepers, a portion cut away to receive one of said ties, a flat crest provided with strips, inclined ways leading to said crest, and provided with a pair of handles attached to the outside of said device for lifting and carrying the same, substantially as described.

4. In combination a replacing-frog comprising an enlarged body portion adapted to span three or more railroad ties or sleepers, a portion cut away to receive one of said ties, a flat crest provided with strips, inclined ways leading to said crest and provided with guides and means for lifting and carrying said device, substantially as described.

In testimony whereof I have hereunto set my hand.

JOHN F. HANIGAN.

In presence of—

FRANK H. LIEDIKE,  
W. J. JACKSON.