



(51) International Patent Classification:

H04W 72/04 (2009.01) H04W 92/10 (2009.01)
H04W 4/00 (2009.01) H04W 92/20 (2009.01)
H04W 4/06 (2009.01)

(21) International Application Number:

PCT/KR2017/000275

(22) International Filing Date:

9 January 2017 (09.01.2017)

(25) Filing Language:

English

(26) Publication Language:

English

(30) Priority Data:

201610021959.2 13 January 2016 (13.01.2016) CN

(71) Applicant: SAMSUNG ELECTRONICS CO., LTD.

[KR/KR]; 129, Samsung-ro, Yeongtong-gu, Suwon-si, Gyeonggi-do 16677 (KR).

(72) Inventors: WANG, Hong; Wangjing, Ganlan Cheng, 9-5-801, Chaoyang District, Beijing 100125 (CN). XU, Lixiang; No. 3, 1302, #1 Jiaotong Daxue Road, Haidian District, Beijing 100125 (CN). KE, Xiaowan; No. 66, Guangqu Road, Chaoyang District, Beijing 100125 (CN).

(74) Agent: YOON, Dong Yol; Yoon & Lee International Patent & Law Firm, 3rd Fl, Ace Highend Tower-5 226, Gasan Digital 1-ro, Geumcheon-gu, Seoul 08502 (KR).

(81) Designated States (unless otherwise indicated, for every kind of national protection available):

AE, AG, AL, AM, AO, AT, AU, AZ, BA, BB, BG, BH, BN, BR, BW, BY, BZ, CA, CH, CL, CN, CO, CR, CU, CZ, DE, DJ, DK, DM, DO, DZ, EC, EE, EG, ES, FI, GB, GD, GE, GH, GM, GT, HN, HR, HU, ID, IL, IN, IR, IS, JP, KE, KG, KH, KN, KP, KR, KW, KZ, LA, LC, LK, LR, LS, LU, LY, MA, MD, ME, MG, MK, MN, MW, MX, MY, MZ, NA, NG, NI, NO, NZ, OM, PA, PE, PG, PH, PL, PT, QA, RO, RS, RU, RW, SA, SC, SD, SE, SG, SK, SL, SM, ST, SV, SY, TH, TJ, TM, TN, TR, TT, TZ, UA, UG, US, UZ, VC, VN, ZA, ZM, ZW.

(84) Designated States (unless otherwise indicated, for every kind of regional protection available):

ARIPO (BW, GH, GM, KE, LR, LS, MW, MZ, NA, RW, SD, SL, ST, SZ, TZ, UG, ZM, ZW), Eurasian (AM, AZ, BY, KG, KZ, RU, TJ, TM), European (AL, AT, BE, BG, CH, CY, CZ, DE, DK, EE, ES, FI, FR, GB, GR, HR, HU, IE, IS, IT, LT, LU, LV, MC, MK, MT, NL, NO, PL, PT, RO, RS, SE, SI, SK, SM, TR), OAPI (BF, BJ, CF, CG, CI, CM, GA, GN, GQ, GW, KM, ML, MR, NE, SN, TD, TG).

Published:

— with international search report (Art. 21(3))

(54) Title: METHOD AND APPARATUS FOR TRANSMITTING V2X MESSAGE

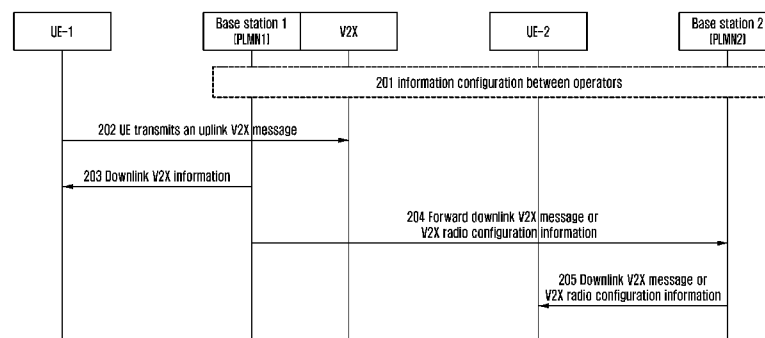

(57) Abstract: The present disclosure relates to a communication method and system for converging a 5th-Generation (5G) communication system for supporting higher data rates beyond a 4th-Generation (4G) system with a technology for Internet of Things (IoT). The present disclosure may be applied to intelligent services based on the 5G communication technology and the IoT-related technology, such as smart home, smart building, smart city, smart car, connected car, health care, digital education, smart retail, security and safety services. The present disclosure provides a method for transmitting a V2X message, including: a first base station receiving an uplink V2X message transmitted by a user equipment (UE), and transmitting a downlink V2X message which is generated based on the uplink V2X message to UEs within coverage of the first base station; the first base station transmitting the downlink V2X message or configuration information for radio resources allocated by the first base station for the downlink V2X message to a second base station of another operator, wherein the second base station transmits the downlink V2X message or the configuration information for the radio resources to UEs within coverage of the second base station; wherein the configuration information for the radio resources is used by the UEs within the coverage of the second base station to receive the downlink V2X message on resources indicated by the configuration information. The solution of the present disclosure enables users of different operators to receive the V2X message.



Description

Title of Invention: METHOD AND APPARATUS FOR TRANSMITTING V2X MESSAGE

Technical Field

- [1] The present disclosure relates to wireless communications technologies, more particularly to a method and an apparatus for transmitting a V2X message.

Background Art

- [2] To meet the demand for wireless data traffic having increased since deployment of 4G communication systems, efforts have been made to develop an improved 5G or pre-5G communication system. Therefore, the 5G or pre-5G communication system is also called a 'Beyond 4G Network' or a 'Post LTE System'. The 5G communication system is considered to be implemented in higher frequency (mmWave) bands, e.g., 60GHz bands, so as to accomplish higher data rates. To decrease propagation loss of the radio waves and increase the transmission distance, the beamforming, massive multiple-input multiple-output (MIMO), Full Dimensional MIMO (FD-MIMO), array antenna, an analog beam forming, large scale antenna techniques are discussed in 5G communication systems. In addition, in 5G communication systems, development for system network improvement is under way based on advanced small cells, cloud Radio Access Networks (RANs), ultra-dense networks, device-to-device (D2D) communication, wireless backhaul, moving network, cooperative communication, Coordinated Multi-Points (CoMP), reception-end interference cancellation and the like. In the 5G system, Hybrid FSK and QAM Modulation (FQAM) and sliding window superposition coding (SWSC) as an advanced coding modulation (ACM), and filter bank multi carrier (FBMC), non-orthogonal multiple access(NOMA), and sparse code multiple access (SCMA) as an advanced access technology have been developed.
- [3] The Internet, which is a human centered connectivity network where humans generate and consume information, is now evolving to the Internet of Things (IoT) where distributed entities, such as things, exchange and process information without human intervention. The Internet of Everything (IoE), which is a combination of the IoT technology and the Big Data processing technology through connection with a cloud server, has emerged. As technology elements, such as "sensing technology", "wired/wireless communication and network infrastructure", "service interface technology", and "Security technology" have been demanded for IoT implementation, a sensor network, a Machine-to-Machine (M2M) communication, Machine Type Communication (MTC), and so forth have been recently researched. Such an IoT environment may provide intelligent Internet technology services that create a new value

to human life by collecting and analyzing data generated among connected things. IoT may be applied to a variety of fields including smart home, smart building, smart city, smart car or connected cars, smart grid, health care, smart appliances and advanced medical services through convergence and combination between existing Information Technology (IT) and various industrial applications.

- [4] In line with this, various attempts have been made to apply 5G communication systems to IoT networks. For example, technologies such as a sensor network, Machine Type Communication (MTC), and Machine-to-Machine (M2M) communication may be implemented by beamforming, MIMO, and array antennas. Application of a cloud Radio Access Network (RAN) as the above-described Big Data processing technology may also be considered to be as an example of convergence between the 5G technology and the IoT technology.
- [5] Modern mobile communications tend to provide multimedia services for users with high transmission rates. FIG. 1 shows a system structure of System Architecture Evolution (SAE) according to the prior art, in which:
- [6] User Equipment (UE) 101 is a terminal device used for receiving data. Evolved Universal Terrestrial Radio Access Network (E-UTRAN) 102 is a radio access network, including an eNodeB/NodeB which provides an interface for the UE to access the radio network. Mobility Management Entity (MME) 103 is responsible for managing mobility context, session context and security information of the UE. Serving Gateway (SGW) 104 is mainly used for providing a user plane function. The MME 103 and the SGW 104 may be in a same physical entity. Packet data network Gateway (PGW) 105 is responsible for charging, legal listening and other functions. The PGW 105 may also be in the same physical entity with the SGW 104. Policy and Charging Rule Function (PCRF) 106 provides QoS policies and charging rules. Serving GPRS Support Node (SGSN) 108 is a network device for providing route for data transmission in a Universal Mobile Telecommunications System (UMTS). Home Subscriber Server (HSS) 109 is a home sub-system of the UE, and is responsible for protecting user information such as current location, serving node location, user security information and packet data context of the user device.
- [7] With rapid development of vehicles, road safety issues have become increasingly prominent. Faced with frequent traffic accidents, traditional methods used for reducing road traffic accidents such as enhancing the transport infrastructure, enhancing traffic safety education has become increasingly limited. Therefore, it is necessary to utilize the information communication technique, to enhance people's awareness about the surroundings of the vehicle via communications between vehicles or between vehicle and road infrastructure. When road risk is detected, the driver and other vehicles may be provided with warning in time to avoid traffic collision. This technique is referred

to as V2X, i.e., vehicle to everything, which is an important technique for future intelligent transportation systems. Through the V2X technique, it is possible to effectively reduce the loss brought out by traffic accidents.

- [8] V2X includes Vehicle-to-Vehicle (V2V), Vehicle-to-Infrastructure (V2I) and Vehicle-to-Pedestrian (V2P). The three V2X communication schemes provide intelligent services for drivers via sensing each other. The transmission facilities, such as vehicles, road infrastructure or pedestrian, can collect environment information utilizing information transmitted by another vehicle or a sensor. Through sharing the information, intelligent services can be provided, e.g., collision warning or automatic driving. These intelligent services may be divided into three classes.
- [9] The first class relates to road safety, including: 1, when a vehicle finds a danger, e.g., there is an obstacle ahead, the vehicle is able to remind other vehicles in time; 2, the vehicle is able to inform others its driving way to help other vehicles to make more accurate decision; 3, provide warning to others when getting close to an intersection; 4, provide warning to others with leaving highway; 5, provide warning to others for temporary/emergency stop; 6, provide warning for vehicle lane change; 7, accident report; 8, warning provided by a car driver to roadside pedestrians/cyclists.
- [10] The second class relates to traffic efficiency, including improvement of traffic fluidity and performing effective measures to solve congestions in real time. The management department may apply traffic rules flexibly according to some detailed conditions, e.g., adjustable speed limit, variable traffic light periodicity and light sequence, intersection automatic vehicle control, way clearing for ambulance/fire engine/police car.
- [11] The third class relates to other applications, e.g., intelligent traffic can provide automatic parking, navigation status and road sign recognition, etc. For the law enforcement department such as the police, the V2X is helpful for the implementation of monitoring, speed limit breaking warning, restricted area management, ordering to stop, etc. Through the electronic payment, the V2X makes the charging for the road toll and parking fees more convenient, which reduces vehicle congestion to some extent and reduce the low-speed rear-end collisions frequently happen at the toll gate.
- [12] For the V2V service, the E-UTRAN enables the UE (in the present disclosure, for the V2V service, the vehicle may act as the UE, the same applies in the following) to exchange V2V relevant information with other adjacent UEs. The exchanging of the V2V relevant information needs to meet the authentication and proximity principle of the E-UTRAN. The proximity principle is configured by the operator. The UE is able to exchange the V2V relevant information even if it is not in the E-UTRAN serving area. The UE supporting the V2V application transmits application layer information, e.g., position and attribute of the UE. The length of the V2V application layer message

is variable, so as to be fit for different information contents. The operator may configure that the V2V message is transmitted periodically. The V2V messages are mainly broadcast messages. The V2V message may be directly transmitted to the nearby UEs, or transmitted to other UEs via a Road Side Unit (RSU).

[13] In the V2I service the UE (in the present disclosure, for the V2I service, the vehicle may act as the UE, the same applies in the following) supporting the V2I application transmits application layer information to the RSU. The RSU transmits the application layer information to a set of UEs supporting the V2I application or to one UE supporting the V2I application.

[14] For the V2P service, the E-UTRAN enables the UE (in the present disclosure, for the V2P service, the vehicle may act as the UE, the same applies in the following) to exchange V2P relevant information with other adjacent UEs. The exchanging of the V2P relevant information needs to meet the authentication and proximity principle of the E-UTRAN. The proximity principle is configured by the operator. The UE is able to exchange the V2P relevant information even if it is not in the E-UTRAN serving area. The V2P message may be directly transmitted to the nearby UEs or transmitted to other UEs via the RSU.

Disclosure of Invention

Technical Problem

[15] The V2X communication may be implemented via the application layer protocol PC5 or through the Uu interface. The V2X message generally relates to public security. Therefore, the V2X message needs to be transmitted to UEs of different operators in the relevant region.

Solution to Problem

[16] Embodiments of the present disclosure provide a method and an apparatus for transmitting a V2X message. Through the present disclosure, V2X service data can be transmitted to all relevant UEs, which reduce traffic accidents and improve traffic efficiency.

[17] The technical solution of the present disclosure includes the following.

[18] A method for transmitting a vehicle to everything message, including:

[19] a first base station receiving an uplink V2X message transmitted by a user equipment (UE), and transmitting a downlink V2X message which is generated based on the uplink V2X message to UEs within coverage of the first base station;

[20] the first base station transmitting the downlink V2X message or configuration information for radio resources allocated by the first base station for the downlink V2X message to a second base station of an operator different from an operator that the first base station belongs to, wherein the second base station transmits the downlink V2X

message or the configuration information for the radio resources to UEs within coverage of the second base station; wherein the configuration information for the radio resources is used by the UEs within the coverage of the second base station to receive the downlink V2X message on resources indicated by the configuration information.

- [21] In some embodiments, the first base station transmits the downlink V2X message to the UEs within the coverage of the first base station via a broadcast manner; and/or
- [22] the second base station transmits the downlink V2X message to the UEs within the coverage of the second base station via a broadcast manner or a unicast manner.
- [23] In some embodiments, the downlink V2X message is transmitted to the second base station via an X2 interface or an S1 interface between base stations; and/or
- [24] the configuration information for the radio resources is transmitted to the second base station via the X2 interface or the S1 interface between base stations.
- [25] In some embodiments, the transmitting the downlink V2X message or the configuration information for the radio resources via the X2 interface between the base stations includes: transmitting the downlink V2X message or the configuration information for the radio resources via a control plane or a user plane of the X2 interface.
- [26] In some embodiments, the transmitting the downlink V2X message or the configuration information for the radio resources via the S1 interface between the base stations includes: the first base station transmitting an eNB configuration transfer message to a core network, wherein the eNB configuration transfer message includes information of the second base station and the downlink V2X message or the configuration information for the radio resources; the core network transmitting the downlink V2X message or the configuration information for the radio resources to the second base station via a Mobility Management Entity (MME) configuration transfer message according to the received eNB configuration transfer message.
- [27] In some embodiments, after receiving the configuration information for the radio resources, the second base station transmitting the downlink V2X message to the UEs within the coverage of the second base station via a broadcast manner or a unicast manner.
- [28] A method for transmitting a vehicle to everything (V2X) message, including:
- [29] a V2X application layer service module connected with a first base station receiving via the first base station an uplink V2X message transmitted by a UE, and transmitting via the first base station a downlink V2X message which is generated based on the uplink V2X message to UEs within coverage of the first base station;
- [30] the V2X application layer service module connected with the first base station transmitting the downlink V2X message to a second base station of an operator different from an operator that the first base station belongs to, wherein the second

base station transmits the downlink V2X message to UEs within coverage of the second base station.

- [31] In some embodiments, the V2X application layer service module transmits the downlink V2X message to the UEs within the coverage of the first base station via the first base station through a broadcast manner or a unicast manner; and/or,
- [32] the second base station transmits the downlink V2X message to the UEs within the coverage of the second base station through the broadcast manner or the unicast manner.
- [33] In some embodiments, the downlink V2X message is transmitted to the second base station via an interface between the V2X application layer service module connected with the first base station and a V2X application layer service module connected with the second base station; or, the downlink V2X message is transmitted to the second base station via an interface between the V2X application layer service module connected with the first base station and the second base station; or, the downlink V2X message is transmitted to the second base station via an interface between an enhanced multimedia broadcast/multicast service (eMBMS) node of the first base station and an eMBMS node of the second base station; or, the downlink V2X message is transmitted to the second base station via an interface between a Multi-cell/multicast Coordination Entity (MCE) for the eMBMS of the first base station and the second base station.
- [34] In some embodiments, the V2X application layer service module transmitting the generated downlink V2X message to the first base station includes: the V2X application layer service module forwarding the downlink V2X message to the first base station via a Broadcast Multicast Service Center (BMSC), a MBMS gateway (MBMS-GW), a MME and a MCE of the operator that the first base station belongs to;
- [35] the transmitting the downlink V2X message via the interface between the eMBMS node for the first base station and the eMBMS node for the second base station includes:
- [36] the V2X application layer service module connected with the first base station transmitting the downlink V2X message to the BMSC of the operator of the first base station, the BMSC transmitting the downlink V2X message to the MCE of the operator of the second base station via the MBMS-GW and the MME of the operator of the second base station; or, the V2X application layer service module connected with the first base station transmitting the downlink V2X message to the BMSC of the operator of the first base station, the BMSC forwarding the downlink V2X message to the MCE of the operator of the second base station via the MBMS-GW and the MME of the operator of the first base station, and the MCE is used for forwarding the downlink V2X message to the second base station.
- [37] In some embodiments, the V2X application layer service module transmitting the

- generated downlink V2X message to the first base station includes: the V2X application layer service module forwarding the downlink V2X message to the first base station via the BMSC, the MBMS-GW and the MME of the operator of the first base station;
- [38] the transmitting the downlink V2X message via the interface between the MCE of the first base station and the second base station includes: the V2X application layer service module connected with the first base station transmitting the downlink V2X message to the BMSC of the operator of the first base station, the BMSC transmitting the downlink V2X message to the MCE of the operator of the first base station via the MBMS-GW and the MME of the operator of the first base station, wherein the MCE forwards the downlink V2X message to the second base station via the interface between the MCE and the second base station established in advance.
- [39] A method for transmitting a vehicle to everything (V2X) message, including:
- [40] a first base station having a V2X capability exchanging configuration information with a base station belongs to an operator different from an operator of the first base station, the configuration information comprises whether a base station has the V2X capability and frequency information for V2X message transmission of the base station;
- [41] according to the exchanged configuration information, the first base station transmitting V2X configuration information to UEs within coverage of the first base station, wherein the V2X configuration information includes information about frequency for V2X message transmission of a base station of another operator, the UEs receives the downlink V2X message of the base station of the another operator on the frequency.
- [42] In some embodiments, the V2X configuration information exchanged between different base stations is transmitted via an X2 interface or an S1 interface between the base stations.
- [43] In some embodiments, the V2X configuration information further includes information about frequency for the downlink V2X message transmission of the first base station.
- [44] A method for receiving a vehicle to everything (V2X) message, including:
- [45] a User Equipment (UE) within coverage of a second base station receiving via the second base station V2X configuration information transmitted by a first base station, wherein the first base station broadcasts a downlink V2X message via an enhanced multimedia broadcast multimedia service (eMBMS) bearer, the second base station belongs to an operator different from the first base station;
- [46] the UE determining according to the received V2X configuration information and a local mapping table that the first base station broadcasts the downlink V2X message on

the eMBMS bearer identified by a Temporary Mobile Group Identity (TMGI), and receiving the downlink V2X message transmitted via the eMBMS bearer, wherein the mapping table comprises a mapping relationship between the V2X configuration information and the TMGI.

- [47] In some embodiments, the mapping table includes a mapping relationship between TMGI-1 of the operator of the first base station and TMGI-2 of the operator of the second base station, the mapping table is saved in the second base station; the V2X configuration information includes the TMGI-1 used by the first base station for identifying the eMBMS bearer, and the TMGI-1 is replaced by the second base station during forwarding with the TMGI-2 used by the second base station according to the mapping table.
- [48] In some embodiments, the mapping table includes a mapping relationship between the TMGI-1 of the operator of the first base station and a V2X service identifier, the V2X configuration information includes the V2X service identifier;
- [49] the UE determining that the first base station broadcasts the downlink V2X message on the eMBMS bearer identified by the TMGI-1 according to the received V2X configuration information and the mapping relationship between the V2X service identifier and the TMGI-1.
- [50] A method for transmitting a vehicle to everything (V2X) message, including:
- [51] a preconfigured node of an operator of a first base station or a second base station receiving a downlink V2X message transmitted from the first base station to the second base station; wherein the first base station broadcasts the downlink V2X message on an eMBMS bearer, the preconfigured node is an eMBMS forwarding node of the operator of the first base station for transmitting the V2X message to the second base station;
- [52] the preconfigured node replacing according to a local mapping table Temporary Mobile Group Identity (TMGI)-1 used by the first base station for identifying the eMBMS bearer with a TMGI-2 used by the second base station, such that UEs within coverage of the second base station receive the downlink V2X message broadcasted by the second base station; wherein the mapping table includes a mapping relationship between the TMGI-1 of the operator of the first base station and the TMGI-2 of the operator of the second base station;
- [53] the preconfigured node transmitting the downlink V2X message after the TMGI-1 is replaced.
- [54] A method for transmitting a vehicle to everything (V2X) message, including:
- [55] a base station receiving an uplink V2X message reported by a user equipment (UE);
- [56] the base station broadcasting a downlink V2X message generated based on the uplink V2X message;

- [57] the downlink V2X message is broadcasted via an eMBMS bearer identified by a dedicated Temporary Mobile Group Identity (TMGI), the dedicated TMGI is allocated for a V2X service in advance and does not include an operator identifier, for the same V2X service, different operators use the same dedicated TMGI.
- [58] An apparatus for transmitting a vehicle to everything (V2X) message, including: an uplink message receiver, a UE transmitter and a base station transmitter;
- [59] the uplink message receiver is configured to receive an uplink V2X message transmitted by a UE;
- [60] the UE transmitter is configured to transmit a downlink V2X message generated based on the uplink V2X message to UEs within coverage of a present base station;
- [61] the base station transmitter is configured to transmit the downlink V2X message or configuration information for radio resources allocated by the present base station to the downlink V2X message to a second base station belonging to an operator different from the present base station, wherein the second base station transmits the downlink V2X message or the configuration information for the radio resources to UEs within coverage of the second base station; the configuration information for the radio resources is used by the UEs within the coverage of the second base station for receiving the downlink V2X message on resources indicated by the configuration information.
- [62] An apparatus for transmitting a vehicle to everything (V2X) message, including: an uplink message receiver, a UE transmitter and a base station transmitter;
- [63] the uplink message receiver is configured to receive via a base station connected with the apparatus an uplink V2X message transmitted by a UE within coverage of the base station;
- [64] the UE transmitter is configured to transmit via the base station connected with the apparatus a downlink V2X message generated based on the uplink V2X message to UEs within the coverage of the base station; and
- [65] the base station transmitter is configured to transmit the downlink V2X message to a second base station of another operator, wherein the second base station transmits the downlink V2X message to UEs within coverage of the second base station.
- [66] An apparatus for transmitting a vehicle to everything (V2X) message, including: a configuration information exchanging unit and a V2X configuration information transmitter;
- [67] the configuration information exchanging unit is configured to exchange configuration information with a base station of another operator different from a present base station; wherein the configuration information includes whether a base station has a V2X capability and information about frequency for V2X message transmission of the base station;

- [68] the V2X configuration information transmitter is configured to transmit V2X configuration information to UEs within the coverage of the present base station according to the exchanged configuration information, wherein the V2X configuration information includes information about frequency for V2X message transmission of the base station of the another operator, the UEs receives the downlink V2X message of the base station of the another operator on the frequency.
- [69] An apparatus for receiving a vehicle to everything (V2X) message, including: a configuration information receiver and a V2X receiver;
- [70] the configuration information receiver is configured to receive via a second base station V2X configuration information transmitted by a first base station; wherein the first base station broadcasts V2X message via an eMBMS bearer, the second base station belongs to an operator different from the first base station; and
- [71] the V2X receiver is configured to determine according to the received V2X configuration information and a local mapping table that the first base station broadcasts the V2X message on the eMBMS bearer identified by a Temporary Mobile Group Identity (TMGI), and receive the downlink V2X message transmitted on the eMBMS bearer, wherein the mapping table includes a mapping relationship between the V2X configuration information and the TMGI.
- [72] An apparatus for transmitting a vehicle to everything (V2X) message, applicable for an eMBMS forwarding node used for transmitting a V2X message from a first base station to a second base station, the apparatus including: a V2X receiver, a Temporary Mobile Group Identity (TMGI) replacing unit and a V2X transmitter;
- [73] the V2X receiver is configured to receive a downlink V2X message transmitted from the first base station to the second base station; wherein the first base station broadcasts the downlink V2X message via an eMBMS bearer;
- [74] the TMGI replacing unit is configured to replace TMGI-1 used by the first base station for identifying the eMBMS bearer with TMGI-2 used by the second base station according to a mapping table, such that user equipment (UEs) within coverage of the second base station receive the downlink V2X message broadcasted by the second base station; wherein the mapping table includes a mapping relationship between the TMGI-1 of an operator of the first base station and the TMGI-2 of an operator of the second base station; and
- [75] the V2X transmitter is configured to transmit the downlink V2X message after the TMGI-1 is replaced.
- [76] An apparatus for transmitting a vehicle to everything (V2X) message, including: a receiver and a broadcasting unit;
- [77] the receiver is configured to receive an uplink V2X message reported by a user equipment (UE); and

- [78] the broadcasting unit is configured to broadcast a downlink V2X message generated based on the uplink V2X message;
- [79] the downlink V2X message is broadcasted via an Enhanced Multimedia Broadcast/Multicast Service (eMBMS) bearer identified by a dedicated Temporary Mobile Group Identity (TMGI), the dedicated TMGI is allocated in advance for a V2X service and does not include an operator identifier, for the same V2X service, different operators use the same dedicated TMGI.

[80]

Advantageous Effects of Invention

- [81] In view of the above technical solution, in the present disclosure, after obtaining the downlink V2X message, the first base station or the V2X application layer service module transmits the downlink V2X message or the configuration information for the radio resources allocated for the downlink V2X message to a second base station which belongs to a different operator and has an overlapped or adjacent coverage area with the first base station, such that the second base station can transmit the downlink V2X message or the configuration information for the radio resources to UEs within its coverage. Therefore, all relevant UEs can receive the V2X message. As such, traffic accident may be reduced and traffic efficiency may be improved. Alternatively, after operators exchange configuration information, the first base station obtains the V2X capability and frequency information for V2X transmission from a base station of another operator, transmits V2X frequency information of the second base station of another operator which has V2X capability and has an overlapped coverage or an adjacent coverage with the first base station to the UEs within the coverage of the first base station via the V2X configuration information. As such, the UEs within the coverage of the first base station can not only receive the V2X message transmitted by the first base station, but also receive the V2X message transmitted by the second base station. Thus, traffic accident may be reduced and traffic efficiency may be improved.

Brief Description of Drawings

- [82] FIG. 1 is a schematic diagram illustrating a system architecture of SAE according to the prior art.
- [83] FIG. 2 is a flowchart illustrating a first method for transmitting V2X message according to various embodiments of the present disclosure.
- [84] FIG. 3 is a flowchart illustrating a second method for transmitting V2X message according to various embodiments of the present disclosure.
- [85] FIG. 4 is a schematic diagram illustrating embodiment 1 of the present disclosure.
- [86] FIG. 5 is a schematic diagram illustrating embodiment 2 of the present disclosure.
- [87] FIG. 6 is a schematic diagram illustrating embodiment 3 of the present disclosure.

[88] FIG. 7 is a schematic diagram illustrating embodiment 4 of the present disclosure.

[89] FIG. 8 is a schematic diagram illustrating embodiments 5 and 6 of the present disclosure.

[90] FIG. 9 is a schematic diagram illustrating embodiment 7 of the present disclosure.

[91] FIG. 10 is a schematic diagram illustrating embodiment 8 of the present disclosure.

Mode for the Invention

[92] The present disclosure will be described in detail hereinafter with reference to accompanying drawings and embodiments to make the technical solution and merits therein clearer.

[93] For a V2X service, vehicles communicating with each other may belong to different operators. As described in the background of the present disclosure, the V2X message needs to be sent to UEs of various operators in the relevant region. Therefore, it is necessary to investigate how to provide the V2X service to users of different operators. As to frequency, different operators may share the same frequency band. At this time, vehicles of different operators may operate on the same frequency to communicate with each other. Different operators may also operate on different frequency bands. At this time, UEs transmit data on merely the frequency supported by their respective operators. Since the V2X message is related to security, the V2X message should be received by any relevant UE, no matter which operator the UE belong to. For example, if vehicle collision happens on the road, a vehicle transmits a message (vehicle collision) to the RSU. The application layer generates a new V2X message which is used for warning other vehicles on the road about the collision. On the road, there may be UEs of different operators and all of the UEs should be able to receive the V2X message transmitted by the application layer.

[94] In order to enable UEs of different operators to receive the V2X message, the present disclosure provides two V2X message transmission methods. In a first method, the base station or a V2X application layer service module coupled to the base station transmits a generated downlink V2X message or V2X radio resource configuration information to a base station of another operator, such that UEs of different operators can receive the V2X message. In the second method, frequency information of a base station of another operator is provided to the UEs of a local base station, such that the UEs are able to receive not only the V2X message transmitted by the local base station but also the downlink V2X message transmitted by the base station of said another operator.

[95] FIG. 2 is a flowchart illustrating a first V2X message transmitting method according to the present disclosure. FIG. 2 shows transmission of the V2X message or the V2X radio configuration information between base stations of different operators. Through

this method, UEs of different operators can receive the V2X message, which helps to reduce traffic accident and improve traffic efficiency. The transmission of the information may be implemented via an X2 interface or via an S1 interface between base stations, or via an interface between V2X application service modules, or via a newly-defined interface between the V2X application layer service module and the base station, i.e. a new interface is defined between the V2X application layer service module of one operator and the base station of another operator. According to the V2X transmission manner, there may be other interfaces, e.g., the V2X message is transmitted by an eMBMS bearer of operator 1, there is an interface between a node (e.g., Broadcast Multicast Service Center (BMSC), MBMS GW or MCE) of the eMBMS and a node (e.g. MBMS GW, MCE or base station) of another operator, and the V2X message or the V2X radio configuration information is transmitted via this interface.

- [96] In step 201, operators exchange configuration information in advance.
- [97] Step 201 is optional. The exchanged configuration information may have various kinds of contents, e.g., whether a base station has V2X capability and/or the frequency allocated by the operator for each base station for transmitting V2X message, etc. The information may be configured via Operation Administration and Maintenance (OAM), and may be transmitted via the X2 interface or via the S1 interface between the base stations.
- [98] If the transmission is implemented via the X2 interface, information such as the frequency on which the base station 1 transmits V2X message and whether the base station 1 has the V2X capability may be included in an X2 connection setup request message transmitted by the base station 1 to the base station 2. Information such as the frequency on which the base station 2 transmits V2X message and whether the base station 2 has the V2X capability may be included in an X2 connection setup response message returned by the base station 2 to the base station 1.
- [99] If the transmission is implemented via the S1 interface, information such as the frequency on which the base station 1 transmits V2X message and whether the base station 1 has the V2X capability may be included in an S1 message transmitted by the base station 1 to the base station 2. The information such as the frequency on which the base station 2 transmits V2X message and whether the base station 2 has the V2X capability may be included in an S1 message returned by the base station 2 to the base station 1.
- [100] In step 202, a UE transmits an uplink V2X message to the base station 1.
- [101] Herein, the base station 1 belongs to the operator 1.
- [102] The UE has the V2X capability. The UE obtains its position and the traffic condition on the road through a sensor. The UE transmits the above information to the base

station 1 via the uplink V2X message. After receiving the uplink V2X message, the base station 1 transmits the uplink V2X message to a V2X application layer service module. The V2X application layer service module is connected with the base station 1. It may be implemented in the base station 1 or may be an independent entity. The base station 1 forwards the uplink V2X message to the V2X application layer service module. The V2X application layer service module processes the uplink V2X message and generates a downlink V2X message. The downlink V2X message is used for providing the traffic condition on the road to other users. Therefore, the downlink V2X message is generally transmitted via a broadcast manner. The V2X application layer service module transmits the downlink V2X message to the base station 1.

[103] In step 203, the base station 1 configures downlink radio resources, and transmits the downlink V2X message to UEs within the coverage of the base station 1.

[104] The base station 1 transmits the downlink V2X message to the UEs within the coverage of the base station 1 via a broadcast manner. The broadcast manner may be a multimedia broadcast multicast service single frequency network (MBSFN) manner, or a cell broadcast manner, or broadcasting via a broadcast channel.

[105] In step 204, the base station 1 or the V2X application layer service module transmits the downlink V2X message or configuration information for the radio resources allocated by the base station 1 for the downlink V2X message to the base station 2.

[106] Herein, the base station 1 belongs to operator 1, and the base station 2 belongs to an operator different from the base station 1, e.g. operator 2.

[107] After receiving the uplink V2X message of the UE, the base station 1 forwards the message to the V2X application layer service module. The V2X application layer service module generates the downlink V2X message and transmits the downlink V2X message to the base station 1. According to the configuration information exchanged in step 201, the base station 1 or the V2X application layer service module knows that the base station 1 needs to provide the downlink V2X message to the UEs of the base station 2. The present disclosure does not restrict that the UEs of which base stations need to be informed, which may be designated in the downlink V2X message or other interface messages according to a practical requirement or may be designated via other manners. For example, in the coverage area of the base station 1, there is a base station 2 of operator 2, i.e., the base station 1 and the base station 2 have an overlapped coverage or adjacent coverage. The base station 1 or the V2X application layer service module transmits the downlink V2X message to the base station 2. The message may be transmitted via the following manners:

[108] via the X2 interface;

[109] via the S1 interface;

[110] via an interface between the V2X application layer service modules connected with

- the base stations;
- [111] via an interface between the V2X application layer service module connected with the base station and the base station;
- [112] via an interface between an eMBMS node for the base station 1 and an eMBMS node for the base station 2; and
- [113] via an interface between a Multi-Cell/Multicast Coordination Entity (MCE) for the base station 1 and the base station 2.
- [114] The above manners are described in detail in the following embodiments.
- [115] Alternatively, the base station 1 or the V2X application layer service module may also transmit to the base station 2 the configuration information for the radio resources allocated for the downlink V2X message. The configuration information may be transmitted via the X2 interface or S1 interface between the base stations, or the configuration information may be transmitted to the base station 2 via an eMBMS node (e.g. mobility management entity, MME) of the operator of the base station 1.
- [116] In step 205, the base station 2 transmits the downlink V2X message or the configuration information for the radio resources allocated for the V2X message to UEs within the coverage of the base station 2.
- [117] The base station 2 receives the downlink V2X message transmitted by the base station 1 or the V2X application layer service module. The base station 2 broadcasts the downlink V2X message to the UEs.
- [118] Alternatively, the base station 2 receives the configuration information for the radio resources allocated by the base station 1 for the V2X message, and transmits the configuration information for the V2X message to the UEs via a broadcast or unicast manner. The configuration information for the radio resources indicates the radio resources configured by the base station 1 of operator 1. The UEs within the coverage of the base station 2 receive the configuration information and can receive the V2X message broadcasted by the base station 1 on corresponding resources at corresponding time. For example, if the base station 1 and the base station 2 operate on the same frequency, the UEs may receive the V2X message broadcasted by the base station 1 on the corresponding resources at the corresponding time. If the base station 1 and the base station 2 operate on different frequencies, in the case that the UE cannot operate on two frequencies at the same time, the UE switches to the frequency of the base station 1 on the time of the V2X broadcast to receive the V2X message; in the case that the UE is able to operate on the two frequencies at the same time, the UE enables the frequency of the base station 1 at the time of the V2X broadcast to receive the V2X message.
- [119] FIG. 3 is a flowchart illustrating a second method for transmitting V2X message according to various embodiments of the present disclosure. FIG. 3 shows an em-

embodiment in which base stations of different operators exchange V2X information and broadcast the nearby V2X information to the UEs. Through this method, UEs of different operators can receive the V2X message, which helps to reduce traffic accident and improve traffic efficiency. The information exchanging may be implemented via an X2 interface or an S1 interface between base stations, or may be configured via operation maintenance.

[120] In step 301, operators exchange configuration information in advance.

[121] The configuration information may include information such as frequency for transmitting V2X message allocated by the operator for each base station, whether the base station has a V2X capability, etc. The information exchanging may be configured by OAM, and may be implemented via the X2 or S1 interface between base stations.

[122] For example, the base station 1 transmits V2X information of the base station 1 to the base station 2. If the V2X information of the base station 1 is transmitted via the X2 interface, the V2X information may be included in the X2 setup request message. If the V2X information of the base station 1 is transmitted via the S1 interface, the base station 1 may transmit an eNB configuration transfer message containing the V2X information of the base station 1 to the core network, the core network transmits an MME configuration transfer message containing the V2X information of the base station 1 to the base station 2. Or, the V2X information may be configured via OAM.

[123] The base station 2 transmits the V2X information of the base station 2 to the base station 1. If the V2X information of the base station 2 is transmitted via the X2 interface, the V2X information may be included in the X2 setup request message. If the V2X information of the base station 2 is transmitted via the S1 interface, the base station 2 may transmit an eNB configuration transfer message containing the V2X information of the base station 2 to the core network, the core network transmits an MME configuration transfer message containing the V2X information of the base station 2 to the base station 1. Or, the V2X information may be configured via OAM.

[124] In step 302, the base station 1 having the V2X capability transmits V2X configuration information to the UEs.

[125] According to the configuration information in step 301, the base station 1 determines that the base station 1 and the base station 2 have an overlapped coverage area or an adjacent area. Therefore, the base station 1 generates V2X configuration information according to the configuration information of the base station 2 and transmits the generated V2X configuration information to the UEs within the coverage of the base station 1. The V2X configuration information includes at least the frequency on which the base station 2 transmits V2X message. For example, in this embodiment, the base station 1 transmits V2X message on frequency 1, the base station 2 transmits V2X message on frequency 2. Thus, the V2X configuration information includes at least the

frequency 2. At the same time, the base station 1 may inform the UEs that the base station 1 supports V2X. The UEs already obtained the frequency 1 of the base station 1 from the existing broadcast information. As such, the UEs know that the V2X message is broadcasted on frequency 1 and frequency 2. The UEs having corresponding capability may receive the V2X messages transmitted on frequencies 1 and 2 at the same time. Certainly, the V2X configuration information may further include the frequency 1.

[126] In step 303, the base station 2 having the V2X capability transmits the V2X configuration information to the UEs.

[127] According to the configuration information in step 301, the base station 2 determines that the base station 1 and the base station 2 have an overlapped coverage area. Therefore, the base station 2 generates V2X configuration information according to the configuration information of the base station 1 and transmits the generated V2X configuration information to the UEs within the coverage of the base station 2. The V2X configuration information includes at least the frequency on which the base station 1 transmits V2X message. For example, in this embodiment, the base station 1 transmits V2X message on frequency 1, the base station 2 transmits V2X message on frequency 2. Thus, the V2X configuration information includes at least the frequency 1. At the same time, the base station 2 may inform the UEs that the base station 2 supports V2X. The UEs already obtained the frequency 2 of the base station 2 from the existing broadcast information. As such, the UEs know that the V2X message is broadcasted on frequency 1 and frequency 2. The UEs having corresponding capability may receive the V2X messages transmitted on frequencies 1 and 2 at the same time. Certainly, the V2X configuration information may further include the frequency 2.

[128] Hereinafter, the implementation of the first method for transmitting V2X message is described with reference to eight embodiments. The first method for transmitting the V2X message may further include two kinds of implementations.

[129] In particular, the first implementation manner includes: the base station 1 receives the uplink V2X message transmitted by the UE, and transmits the downlink V2X message which is generated based on the uplink V2X message to UEs within the coverage of the base station 1; the base station 1 transmits the downlink V2X message or configuration information for radio resources allocated by the base station 1 for the downlink V2X message to the base station 2 which belongs to another operator (for example, a base station having an overlapped coverage area with the base station 1 or an adjacent base station), such that the base station 2 transmits the downlink V2X message or the radio resource configuration information to UEs within the coverage of the base station 2. The radio resource configuration information is used by the UEs within the coverage of the base station 2 for receiving the downlink V2X message on

the indicated resources.

- [130] The second implementation manner includes: the V2X application layer service module connected with the base station 1 receives the uplink V2X message transmitted by the UE, and transmits via the base station 1 a downlink V2X message which is generated based on the uplink V2X message to the UEs within the coverage of the base station 1; the V2X application layer service module connected with the base station 1 transmits the downlink V2X message to the base station 2 which belongs to another operator (e.g., a base station having an overlapped coverage area with the base station 1 or a base station adjacent to the base station 1), such that the base station 2 transmits the downlink V2X message to the UEs within the coverage of the base station 2.
- [131] Hereinafter, the information interaction in the first implementation manner is described with reference to embodiments 1, 2, 7 and 8, and the information interaction in the second implementation manner is described with reference to embodiments 3 to 6.
- [132] FIG. 4 shows embodiment 1 of the present disclosure. FIG. 4 shows the transmission of the V2X message between base stations of different operators. Through this method, UEs of different operators can receive the downlink V2X message, which reduces traffic accident and improves traffic efficiency. The information transmission may be implemented via the X2 interface between the base stations.
- [133] In step 401, a UE transmits an uplink V2X message to the base station 1. The base station 1 belongs to operator 1.
- [134] Before step 401, step 201 as shown in FIG. 2 may be executed or not, which is not restricted in the present disclosure.
- [135] In step 401, the UE has the V2X capability. The UE obtains its position and the traffic condition on the road via a sensor. The UE transmits the above information to the base station 1 via the uplink V2X message. The base station 1 receives the uplink V2X message and transmits the message to the V2X application layer service module. The V2X application layer service module is connected with the base station 1. It may be implemented in the base station 1 or implemented as an independent entity. The base station 1 forwards the uplink V2X message to the V2X application layer service module. The V2X application layer service module processes the uplink V2X message and generates a downlink V2X message, wherein the downlink V2X message is used for informing other users of the traffic condition on the road. Therefore, the downlink V2X message is generally transmitted via a broadcast manner.
- [136] In step 402, the V2X application layer service module transmits the downlink V2X message to the base station 1.
- [137] In step 403, the base station 1 configures downlink radio resources for the downlink V2X message, and transmits the downlink V2X message to the UEs within the

coverage of the base station 1.

[138] Generally, the base station 1 transmits the downlink V2X message to UEs within the coverage of the base station 1 via a broadcast manner. The broadcast manner may include a MBSFN manner, or a cell broadcast manner, or broadcasting via a broadcast channel, or other broadcast manners. Or, the base station 1 may transmit the downlink V2X message via a unicast manner. Detailed implementation of step 403 may vary with different manners for transmitting the downlink V2X message. If the downlink V2X message is transmitted via the MBSFN manner or the cell broadcast manner, step 403 includes: the base station 1 transmits radio resource configuration information for the MBSFN to the UEs and transmits the downlink V2X message on the resources. If the downlink V2X message is broadcasted via the broadcast channel, step 403 includes: the base station 1 directly transmits the downlink V2X message to the UEs via a newly-defined broadcast message. If the downlink V2X message is transmitted via other broadcast manners or the unicast manner, step 403 may include configuring the radio resources for the broadcast or the unicast and transmitting the downlink V2X message on the configured resources.

[139] In step 404, the base station 1 forwards the downlink V2X message to the base station 2, wherein the base station 2 belongs to an operator different from the base station 1, e.g., the base station 1 belongs to operator 1 and the base station 2 belongs to operator 2.

[140] The base station 1 and the base station 2 have an overlapped coverage area or have adjacent coverage areas. The base station 1 belongs to operator 1 and the base station 2 belongs to operator 2. The base station 1 receives the uplink V2X message of the user and forwards the message to the V2X application layer service module. The V2X application layer service module generates the downlink V2X message and transmits the downlink V2X message to the base station 1. According to the information configured in step 201, the base station 1 knows that there is the base station 2 of operator 2 within its coverage. Therefore, the base station 1 needs to inform the UEs within the coverage of the base station 2 of the downlink V2X message. The base station 1 transmits the downlink V2X message to the base station 2 via an X2 interface between the base station 1 and the base station 2. The message may be transmitted in the control plane or user plane of the X2 interface.

[141] In step 405, the base station 2 configures downlink radio resources for the downlink V2X message, and transmits the downlink V2X message to UEs within its coverage.

[142] Similarly, step 405 may vary with respect to different transmission manners of the downlink V2X message. Reference may be made to step 403 for the details.

[143] Now, embodiment 1 is finished.

[144]

- [145] FIG. 5 shows embodiment 2 of the present disclosure. FIG. 5 shows the transmission of V2X message between base stations of different operators. Through this method, UEs of different operators can receive the V2X message, which reduces traffic accident and improves traffic efficiency. The information transmission may be implemented via the S1 interface between the base stations.
- [146] In step 501, a UE transmits an uplink V2X message to the base station 1. The base station 1 belongs to operator 1.
- [147] Before step 501, step 201 as shown in FIG. 2 may be executed or not, which is not restricted in the present disclosure.
- [148] In step 501, the UE has the V2X capability. The UE obtains its position and the traffic condition on the road via a sensor. The UE transmits the above information to the base station 1 via the uplink V2X message. The base station 1 receives the uplink V2X message and transmits the message to the V2X application layer service module. The V2X application layer service module is connected with the base station 1. It may be implemented in the base station 1 or implemented as an independent entity. The base station 1 forwards the uplink V2X message to the V2X application layer service module. The V2X application layer service module processes the uplink V2X message and generates a downlink V2X message, wherein the downlink V2X message is used for informing other users of the traffic condition on the road. Therefore, the downlink V2X message is generally transmitted via a broadcast manner.
- [149] In step 502, the V2X application layer service module transmits the downlink V2X message to the base station 1.
- [150] In step 503, the base station 1 configures downlink radio resources for the downlink V2X message, and transmits the downlink V2X message to the UEs within the coverage of the base station 1.
- [151] Generally, the base station 1 transmits the downlink V2X message to UEs within the coverage of the base station 1 via a broadcast manner. The broadcast manner may include a MBSFN manner, or a cell broadcast manner, or broadcasting via a broadcast channel, or other broadcast manners. Or, the base station 1 may transmit the downlink V2X message via a unicast manner. Detailed implementation of step 503 may vary with different manners for transmitting the downlink V2X message. If the downlink V2X message is transmitted via the MBSFN manner or the cell broadcast manner, step 503 includes: the base station 1 transmits radio resource configuration information for the MBSFN to the UEs and transmits the downlink V2X message on the resources. If the downlink V2X message is broadcasted via the broadcast channel, step 503 includes: the base station 1 directly transmits the downlink V2X message to the UEs via a newly-defined broadcast message. If the downlink V2X message is transmitted via other broadcast manners or the unicast manner, step 503 may include configuring

the radio resources for the broadcast or the unicast and transmitting the downlink V2X message on the configured resources.

[152] In step 504, the base station 1 forwards the downlink V2X message to the base station 2, wherein the base station 2 belongs to an operator different from the base station 1, e.g., the base station 1 belongs to operator 1 and the base station 2 belongs to operator 2.

[153] The base station 1 and the base station 2 have an overlapped coverage or have adjacent coverage areas. The base station 1 belongs to operator 1 and the base station 2 belongs to operator 2. The base station 1 receives the uplink V2X message of the user and forwards the message to the V2X application layer service module. The V2X application layer service module generates the downlink V2X message and transmits the downlink V2X message to the base station 1. According to the information configured in step 201, the base station 1 knows that there is the base station 2 of operator 2 within its coverage. Therefore, the base station 1 needs to inform the UEs within the coverage of the base station 2 of the downlink V2X message. There is no X2 interface between the base station 1 and the base station 2. The base station 1 transmits the downlink V2X message to the base station 2 via an S1 interface. The base station 1 transmits an eNB configuration transfer message containing information of a destination base station the downlink V2X message to the core network. The core network transmits an MME configuration transfer message containing the downlink V2X message to the base station 2. The transmission within the core network may involve two MME nodes. MME1 connected with the base station 1 finds MME2 connected with the base station 2 according to the destination address contained in the message and then transmits the message to the base station 2 via MME2.

[154] In step 505, the base station 2 configures downlink radio resources for the downlink V2X message, and transmits the downlink V2X message to UEs within its coverage.

[155] Similarly, step 505 may vary with respect to different transmission manners of the downlink V2X message. Reference may be made to step 503 for the details.

[156] Now, embodiment 2 is finished.

[157] FIG. 6 shows embodiment 3 of the present disclosure. FIG. 6 shows the transmission of V2X message between V2X application layer service modules of different operators. Through this method, users of different operators can receive the downlink V2X message, which reduces traffic accident and improves traffic efficiency. The information transmission may be implemented via an interface between the V2X application layer service modules.

[158] In step 601, a UE transmits an uplink V2X message to the base station 1, wherein the base station 1 belongs to operator 1.

[159] Before step 601, step 201 as shown in FIG. 2 may be executed or not, which is not

restricted in the present disclosure.

[160] In step 601, the UE has the V2X capability. The UE obtains its position and the traffic condition on the road via a sensor. The UE transmits the above information to the base station 1 via the uplink V2X message. The base station 1 receives the uplink V2X message and transmits the message to the V2X application layer service module. The V2X application layer service module is connected with the base station 1. It may be implemented in the base station 1 or implemented as an independent entity. The base station 1 forwards the uplink V2X message to the V2X application layer service module. The V2X application layer service module processes the uplink V2X message and generates a downlink V2X message, wherein the downlink V2X message is used for informing other users of the traffic condition on the road. Therefore, the downlink V2X message is generally transmitted via a broadcast manner.

[161] In step 602, the V2X application layer service module transmits the downlink V2X message to the base station 1.

[162] In step 603, the base station 1 configures downlink radio resources and transmits the downlink V2X message to UEs within its coverage.

[163] Generally, the base station 1 transmits the downlink V2X message to UEs within the coverage of the base station 1 via a broadcast manner. The broadcast manner may include a MBSFN manner, or a cell broadcast manner, or broadcasting via a broadcast channel, or other broadcast manners. Or, the base station 1 may transmit the downlink V2X message via a unicast manner. Detailed implementation of step 603 may vary with different manners for transmitting the downlink V2X message. If the downlink V2X message is transmitted via the MBSFN manner or the cell broadcast manner, step 603 includes: the base station 1 transmits radio resource configuration information for the MBSFN to the UEs and transmits the downlink V2X message on the resources. If the downlink V2X message is broadcasted via the broadcast channel, step 603 includes: the base station 1 directly transmits the downlink V2X message to the UEs via a newly-defined broadcast message. If the downlink V2X message is transmitted via other broadcast manners or the unicast manner, step 603 may include configuring the radio resources for the broadcast or the unicast and transmitting the downlink V2X message on the configured resources.

[164] In step 604, the V2X application layer service module forwards the downlink V2X message to the V2X application layer service module connected with the base station 2.

[165] The base station 1 and the base station 2 have an overlapped coverage area or have adjacent coverage areas. The base station 1 belongs to operator 1 and the base station 2 belongs to operator 2. The base station 1 receives the uplink V2X message of the user and forwards the message to the V2X application layer service module. The V2X ap-

plication layer service module generates the downlink V2X message. According to the information configured in step 201, the V2X application layer service module connected with the base station 1 knows that the message needs to be transmitted to the UEs under base stations 1 and 2. The V2X application layer service module connected with the base station 1 forwards the downlink V2X message to the V2X application layer service module connected with the base station 2. Suppose that each base station has a local V2X application function. Thus, it is possible to transmit the downlink V2X message to the application layer of the base station 2 via the application layer of the base station 1.

[166] In the above procedure, as to how the V2X application layer service module knows that it needs to transmit the downlink V2X message to the UEs under base stations 1 and 2 according to the information configured in step 201, the present disclosure does not have any restriction. For example, the V2X application layer service module may obtain the information configured in step 201 from the base station 1, so as to know the corresponding information.

[167] In step 605, the V2X application layer service module connected with the base station 2 transmits the downlink V2X message to the base station 2.

[168] In step 606, the base station 2 configures downlink radio resources for the downlink V2X message and transmits the downlink V2X message to UEs within its coverage.

[169] Similarly, step 606 may vary with respect to different transmission manners of the downlink V2X message. Reference may be made to step 603 for details.

[170] Now, embodiment 3 is finished.

[171]

[172] FIG. 7 shows embodiment 4 of the present disclosure. FIG. 7 shows the transmission of the V2X message between the V2X application layer service modules of different operators. Through this method, users of different operators can receive the downlink V2X message, which reduces traffic accident and improves traffic efficiency. The information may be transmitted to the MBMS-GW of operator 2 via the BMSC of operator 1, or may be transmitted to the MCE of operator 2 via the MBMS-GW of operator 1.

[173] In step 701, a UE transmits an uplink V2X message to the base station 1, wherein the base station 1 belongs to operator 1.

[174] Before step 701, step 201 as shown in FIG. 2 may be executed or not, which is not restricted in the present disclosure.

[175] In step 701, the UE has the V2X capability. The UE obtains its position and the traffic condition on the road via a sensor. The UE transmits the above information to the base station 1 via the uplink V2X message. The base station 1 receives the uplink V2X message and transmits the message to the V2X application layer service module.

The V2X application layer service module is connected with the base station 1. It may be implemented in the base station 1 or implemented as an independent entity. The base station 1 forwards the uplink V2X message to the V2X application layer service module. The V2X application layer service module processes the uplink V2X message and generates a downlink V2X message, wherein the downlink V2X message is used for informing other users of the traffic condition on the road. Therefore, the downlink V2X message is generally transmitted via a broadcast manner.

- [176] In step 702, the V2X application layer service module transmits the downlink V2X message to the BMSC of the operator of the base station 1.
- [177] In step 703, the BMSC transmits a session start message including the downlink V2X message to the MBMS-GW, the MBMS-GW transmits the session start message to the MCE via the MME. The transmission path of the message is similar to that of the existing session start message.
- [178] In step 704, the MCE of the operator of the base station 1 transmits a service start response message to the BMSC via the MME and the MBMS-GW.
- [179] Step 704 is transmission procedure of the MBMS session start response message, i.e., the MCE transmits the session start response message to the MME, the MME transmits the session start response message to the MBMS-GW, and the MBMS-GW transmits the session start response message to the BMSC. The path of the response message is similar to that the existing session start response message.
- [180] In step 705, the MCE of the operator of the base station 1 transmits the session start message including the downlink V2X message to the base station 1.
- [181] In step 706, the base station 1 transmits a session start response message to the MCE.
- [182] In step 707, the base station 1 transmits the downlink V2X message to the UEs.
- [183] Generally, the base station 1 transmits the downlink V2X message to UEs within its coverage via a broadcast manner. The broadcast manner may include a MBSFN manner, or a cell broadcast manner, or broadcasting via a broadcast channel, or other broadcast manners. Or, the base station 1 may transmit the downlink V2X message via a unicast manner. Detailed implementation of step 707 may vary with different manners for transmitting the downlink V2X message. If the downlink V2X message is transmitted via the MBSFN manner or the cell broadcast manner, step 707 includes: the base station 1 transmits radio resource configuration information for the MBSFN to the UEs and transmits the downlink V2X message on the resources. If the downlink V2X message is broadcasted via the broadcast channel, step 707 includes: the base station 1 directly transmits the downlink V2X message to the UEs via a newly-defined broadcast message. If the downlink V2X message is transmitted via other broadcast manners or the unicast manner, step 707 may include configuring the radio resources for the broadcast or the unicast and transmitting the downlink V2X message on the

configured resources.

[184] In step 708, the BMSC transmits the session start message including the downlink V2X message to the MCE of operator 2 via the MBMS-GW and the MME of operator 2.

[185] The base station 1 and the base station 2 have an overlapped coverage area or are adjacent base stations. The base station 1 belongs to operator 1 and the base station 2 belongs to operator 2. The MBSC of operator 1 and the MBMS-GW of operator 2 have a connection in advance. The BMSC of operator 1 transmits the session start message including the downlink V2X message to the MBMS-GW of operator 2. The MBMS-GW of operator 2 transmits the session start message to the corresponding MME. Then the MME forwards the session start message to the MCE. The subsequent procedure is similar to existing eMBMS procedure.

[186] Alternatively, in step 708, the MME of operator 1 transmits the session start message including the downlink V2X message to the MCE of operator 2.

[187] The base station 1 and the base station 2 have an overlapped coverage area or are adjacent base stations. The base station 1 belongs to operator 1 and the base station 2 belongs to operator 2. Operator 2 configures that the MCE needs to establish an M3 interface with a particular MME of operator 1. Before step 708, the MCE has established the M3 interface with the MME of operator 1. After receiving the session start request, the MME knows that the session is used for transmitting downlink V2X message. The MME transmits the session start message to the MCE of operator 1 or to the MCE of operator 2.

[188] In step 709, the MCE of operator 2 transmits a session start response message to the BMSC via the MME and MBMS-GW of operator 1.

[189] Step 709 is a transmission procedure of the MBMS session start response message, i.e., the MCE transmits the session start response message to the MME, the MME transmits the session start response message to the MBMS-GW, and the MBMS-GW transmits the session start response message to the BMSC. The path of the response message is similar to that of the existing session start response message.

[190] In step 710, the MCE of operator 2 transmits the session start message including the downlink V2X message to the base station 2.

[191] In step 711, the base station 2 transmits the session start response message to the MCE of operator 2.

[192] In step 712, the base station 2 transmits the downlink V2X message to the UEs.

[193] Similarly, step 712 may vary with respect to different transmission manners of the downlink V2X message. Reference may be made to step 707 for details.

[194] Now, embodiment 4 is finished.

[195]

- [196] FIG. 8 shows embodiment 5 of the present disclosure. FIG. 8 shows the transmission of the V2X message between base stations of different operators. Through this method, users of different operators can receive the downlink V2X message, which reduces traffic accident and improves traffic efficiency. The information may be transmitted to the MCE of operator 1 via the BMSC and MBMS-GW of operator 1, and then transmitted to the base station of operator 2 from the MCE of operator 1.
- [197] In step 801, a UE transmits an uplink V2X message to the base station 1, wherein the base station 1 belongs to operator 1.
- [198] Before step 801, step 201 as shown in FIG. 2 may be executed or not, which is not restricted in the present disclosure.
- [199] In step 801, the UE has the V2X capability. The UE obtains its position and the traffic condition on the road via a sensor. The UE transmits the above information to the base station 1 via the uplink V2X message. The base station 1 receives the uplink V2X message and transmits the message to the V2X application layer service module. The V2X application layer service module is connected with the base station 1. It may be implemented in the base station 1 or implemented as an independent entity. The base station 1 forwards the uplink V2X message to the V2X application layer service module. The V2X application layer service module processes the uplink V2X message and generates a downlink V2X message, wherein the downlink V2X message is used for informing other users of the traffic condition on the road. Therefore, the downlink V2X message is generally transmitted via a broadcast manner.
- [200] In step 802, the V2X application layer service module transmits the downlink V2X message to the BMSC of the operator of the base station 1.
- [201] In step 803, the BMSC of the operator of the base station 1 transmits a session start message including the downlink V2X message to the MBMS-GW, the MBMS-GW transmits the session start message to the MCE via the MME. The transmission path of the message is similar to that of the existing session start message.
- [202] In step 804, the MCE of the operator of the base station 1 transmits a service start response message to the BMSC via the MME and the MBMS-GW.
- [203] Step 804 is transmission procedure of the MBMS session start response message, i.e., the MCE transmits the session start response message to the MME, the MME transmits the session start response message to the MBMS-GW, and the MBMS-GW transmits the session start response message to the BMSC. The path of the response message is similar to that the existing session start response message.
- [204] In step 805, the MCE of the operator of the base station 1 transmits the session start message including the downlink V2X message to the base station 1.
- [205] In step 806, the base station 1 transmits a session start response message to the MCE.
- [206] In step 807, the base station 1 transmits the downlink V2X message to the UEs.

- [207] Generally, the base station 1 transmits the downlink V2X message to users within its coverage via a broadcast manner. The broadcast manner may include a MBSFN manner, or a cell broadcast manner, or broadcasting via a broadcast channel, or other broadcast manners. Or, the base station 1 may transmit the downlink V2X message via a unicast manner. Detailed implementation of step 807 may vary with different manners for transmitting the downlink V2X message. If the downlink V2X message is transmitted via the MBSFN manner or the cell broadcast manner, step 807 includes: the base station 1 transmits radio resource configuration information for the MBSFN to the UEs and transmits the downlink V2X message on the resources. If the downlink V2X message is broadcasted via the broadcast channel, step 807 includes: the base station 1 directly transmits the downlink V2X message to the UEs via a newly-defined broadcast message. If the downlink V2X message is transmitted via other broadcast manners or the unicast manner, step 807 may include configuring the radio resources for the broadcast or the unicast and transmitting the downlink V2X message on the configured resources.
- [208] In step 808, the MCE of the operator of the base station 1 transmits the session start message including the downlink V2X message to the base station 2.
- [209] The base station 1 and the base station 2 have an overlapped coverage area or are adjacent base stations. The base station 1 belongs to operator 1 and the base station 2 belongs to operator 2. The MCE of operator 1 and the base station of operator 2 have a connection in advance. The base station 2 has established an M2 interface with the MCE. The MCE has established an M2 interface with the base station operator 1. The MCE receives the session start request, and knows that the session is used for transmitting downlink V2X message. The MCE transmits the session start message to the base station of operator 1 or the base station of operator 2.
- [210] In step 809, the base station 2 transmits the session start response message to the MCE.
- [211] In step 810, the base station 2 transmits the downlink V2X message to the UEs.
- [212] Similarly, step 810 may vary with respect to different transmission manners of the downlink V2X message. Reference may be made to step 807 for details.
- [213] Now, embodiment 5 is finished.
- [214] FIG. 8 may also be used for illustrating another implementation method, i.e. embodiment 6. A broadcast system is especially deployed for the V2X service, e.g. functions such as BMSC, MBMS-GW and MCE may be configured on one physical entity or multiple physical entities, dedicated for transmitting the downlink V2X message. All base stations within a certain area, whichever operator that the base station belongs to, need to establish an M2 interface with the MCE. Embodiment 6 is described with reference to FIG. 8. It includes the following steps.

- [215] In step 801, a UE transmits an uplink V2X message to the base station 1, wherein the base station 1 belongs to operator 1.
- [216] Before step 801, step 201 as shown in FIG. 2 may be executed or not, which is not restricted in the present disclosure.
- [217] In step 801, the UE has the V2X capability. The UE obtains its position and the traffic condition on the road via a sensor. The UE transmits the above information to the base station 1 via the uplink V2X message. The base station 1 receives the uplink V2X message and transmits the message to the V2X application layer service module. The V2X application layer service module is connected with the base station 1. It may be implemented in the base station 1 or implemented as an independent entity. The base station 1 forwards the uplink V2X message to the V2X application layer service module. The V2X application layer service module processes the uplink V2X message and generates a downlink V2X message, wherein the downlink V2X message is used for informing other users of the traffic condition on the road. Therefore, the downlink V2X message is generally transmitted via a broadcast manner.
- [218] In step 802, the V2X application layer service module transmits the downlink V2X message to the BMSC in the area where it is located. The BMSC may be an independent entity or may be combined with other physical entities.
- [219] In step 803, the BMSC of the operator of the base station 1 transmits a session start message including the downlink V2X message to the MCE. If the existing transmission path is adopted, the BMSC transmits the session start message to the MBMS-GW. The MBMS-GW transmits the session start message to the MCE via the MME. The transmission path of the message is similar to that of the existing session start message. For simplicity, the MBMS-GW may directly transmit the session start message to the MCE, or the BMSC transmits the session start message to the MCE.
- [220] In step 804, the MCE of the operator of the base station 1 transmits a session start response message to the BMSC via the MME and the MBMS-GW.
- [221] Step 804 is a transmission procedure of the MBMS session start response message, i.e., the MCE transmits the session start response message to the MME, the MME transmits the session start response message to the MBMS-GW, and the MBMS-GW transmits the session start response message to the BMSC. The transmission path of the response message is similar to that of the existing session start response message.
- [222] In step 805, the MCE of the operator of the base station 1 transmits a session start message including the V2X message to the base station 1. The MCE determines to adopt the MBSFN manner. The MCE transmits the session start request message to all base stations within the area, including the base station 1 and the base station 2. Or, the MCE may determine to adopt the cell broadcast manner. The MCE determines in which cells it broadcasts and transmits the session start request message to the corre-

sponding base stations. The session start request message includes identifiers of a set of cells. According to the identifiers, the MCE transmits the session start request message to the base stations corresponding to the identifiers.

[223] In step 806, the base station 1 transmits a session start response message to the MCE.

[224] In step 807, the base station 1 transmits the downlink V2X message to the UEs.

[225] Generally, the base station 1 transmits the downlink V2X message to users within its coverage via a broadcast manner. The broadcast manner may include a MBSFN manner, or a cell broadcast manner, or broadcasting via a broadcast channel, or other broadcast manners. Or, the base station 1 may transmit the downlink V2X message via a unicast manner. Detailed implementation of step 807 may vary with different manners for transmitting the downlink V2X message. If the downlink V2X message is transmitted via the MBSFN manner or the cell broadcast manner, step 807 includes: the base station 1 transmits radio resource configuration information for the MBSFN to the UEs and transmits the downlink V2X message on the resources. If the downlink V2X message is broadcasted via the broadcast channel, step 807 includes: the base station 1 directly transmits the downlink V2X message to the UEs via a newly-defined broadcast message. If the downlink V2X message is transmitted via other broadcast manners or the unicast manner, step 807 may include configuring the radio resources for the broadcast or the unicast and transmitting the downlink V2X message on the configured resources.

[226] In step 808, the MCE of the operator that the base station 1 belongs to transmits the session start message including the downlink V2X message to the base station 2.

[227] The base station 1 and the base station 2 have an overlapped coverage area or are adjacent base stations. The base station 1 belongs to operator 1 and the base station 2 belongs to operator 2. The base station 2 has established an M2 interface with the MCE. The MCE has established an M2 interface with the base station of operator 1. The MCE receives the session start request and knows that the session is for transmitting the downlink V2X message. The MCE transmits a session start message to the base station of operator 1 or the base station of operator 2. Or, the session start request message includes identifiers of a set of cells. According to the identifiers, the MCE transmits the session start request to the base stations corresponding to the identifiers.

[228] In step 809, the base station 2 transmits a session start response message to the MCE.

[229] In step 810, the base station 2 transmits the downlink V2X message to the UEs.

[230] Similarly, step 810 may vary with respect to different transmission manners of the downlink V2X message. Reference may be made to step 807 for details.

[231] Now, embodiment 6 is finished.

[232]

- [233] FIG. 9 shows embodiment 7 of the present disclosure.
- [234] FIG. 9 shows the transmission of V2X radio configuration information between base stations of different operators. Through this method, users of different operators can receive the downlink V2X message, which reduces traffic accident and improves traffic efficiency. The information may be transmitted via the X2 interface between the base stations.
- [235] In step 901, a UE transmits an uplink V2X message to the base station 1, wherein the base station 1 belongs to operator 1.
- [236] Before step 901, step 201 as shown in FIG. 2 may be executed or not, which is not restricted in the present disclosure.
- [237] In step 901, the UE has the V2X capability. The UE obtains its position and the traffic condition on the road via a sensor. The UE transmits the above information to the base station 1 via the uplink V2X message. The base station 1 receives the uplink V2X message and transmits the message to the V2X application layer service module. The V2X application layer service module is connected with the base station 1. It may be implemented in the base station 1 or implemented as an independent entity. The base station 1 forwards the uplink V2X message to the V2X application layer service module. The V2X application layer service module processes the uplink V2X message and generates a downlink V2X message, wherein the downlink V2X message is used for informing other users of the traffic condition on the road. Therefore, the downlink V2X message is generally transmitted via a broadcast manner.
- [238] In step 902, the V2X application layer service module transmits the downlink V2X message to the base station 1.
- [239] In step 903, the base station 1 configures downlink radio resources and transmits the downlink V2X message to all UEs within the coverage of the base station 1.
- [240] Generally, the base station 1 transmits the downlink V2X message to users within its coverage via a broadcast manner. The broadcast manner may include a MBSFN manner, or a cell broadcast manner, or broadcasting via a broadcast channel, or other broadcast manners. Or, the base station 1 may transmit the downlink V2X message via a unicast manner. Detailed implementation of step 903 may vary with different manners for transmitting the downlink V2X message. If the downlink V2X message is transmitted via the MBSFN manner or the cell broadcast manner, step 903 includes: the base station 1 transmits radio resource configuration information for the MBSFN to the UEs and transmits the downlink V2X message on the resources. If the downlink V2X message is broadcasted via the broadcast channel, step 903 includes: the base station 1 directly transmits the downlink V2X message to the UEs via a newly-defined broadcast message. If the downlink V2X message is transmitted via other broadcast manners or the unicast manner, step 903 may include configuring the radio resources

for the broadcast or the unicast and transmitting the downlink V2X message on the configured resources.

[241] In step 904, the base station 1 transmits V2X radio configuration information to the base station 2. The base station 1 and the base station 2 belong to different operators, e.g. base station belongs to operator 1 and the base station 2 belongs to operator 2.

[242] The base station 1 and the base station 2 have an overlapped coverage area or are adjacent base stations. The base station 1 belongs to operator 1 and the base station 2 belongs to operator 2. The base station 1 receives the uplink V2X message of the user and forwards the uplink V2X message to the V2X application layer service module. The V2X application layer service module generates a downlink V2X message and transmits the downlink V2X message to the base station 1. According to the information configured in step 201, the base station 1 knows that there is a base station 2 of operator 2 within its coverage. The base station 1 needs to inform the UEs of the base station 2 of the V2X radio configuration information. The information may be transmitted via the control plane or the user plane of the X2 interface.

[243] In step 905, the base station 2 transmits the V2X radio configuration information to the UEs within the coverage of the base station 2.

[244] The base station 2 receives from the base station 1 the configuration information of the radio resources allocated by the base station 1 for the downlink V2X message. The base station 2 transmits the V2X radio configuration information to the UEs via a broadcast manner or a unicast manner. The radio resource configuration information defines the radio resources configured by the base station 1 of operator 1. After receiving the configuration information, respective UE of operator 2 may receive the downlink V2X message on the corresponding resources at the corresponding time. For example, if the base station 1 and the base station 2 use the same frequency, the UE may receive the downlink V2X message broadcasted by the base station 1 on the corresponding resources at the corresponding time via a TDD manner. If the base station 1 and the base station 2 use different frequencies, in the case that the UE does not have the capability of operating on the two frequencies at the same time, the UE may switch to the frequency of the base station 1 to receive the downlink V2X message at the time of the V2X broadcast; in the case that the UE has the capability of operating on the two frequencies at the same time, the UE may enable the frequency of the base station 1 to receive the downlink V2X message at the time of the V2X broadcast.

[245] Now, embodiment 7 is finished.

[246]

[247] FIG. 10 shows embodiment 8 of the present disclosure. FIG. 10 shows the transmission of V2X radio configuration information between base stations of different operators. Through this method, users of different operators can receive the V2X

message, which reduces traffic accident and improves traffic efficiency. The information may be transmitted via the S1 interface between the base stations.

[248] In step 1001, a UE transmits an uplink V2X message to the base station 1, wherein the base station 1 belongs to operator 1.

[249] Before step 1001, step 201 as shown in FIG. 2 may be executed or not, which is not restricted in the present disclosure.

[250] In step 1001, the UE has the V2X capability. The UE obtains its position and the traffic condition on the road via a sensor. The UE transmits the above information to the base station 1 via the uplink V2X message. The base station 1 receives the uplink V2X message and transmits the message to the V2X application layer service module. The V2X application layer service module is connected with the base station 1. It may be implemented in the base station 1 or implemented as an independent entity. The base station 1 forwards the uplink V2X message to the V2X application layer service module. The V2X application layer service module processes the uplink V2X message and generates a downlink V2X message, wherein the downlink V2X message is used for informing other users of the traffic condition on the road. Therefore, the downlink V2X message is generally transmitted via a broadcast manner.

[251] In step 1002, the V2X application layer service module transmits the downlink V2X message to the base station 1.

[252] In step 1003, the base station 1 configures downlink radio resources and transmits the downlink V2X message to UEs within the coverage of the base station 1.

[253] Generally, the base station 1 transmits the downlink V2X message to users within its coverage via a broadcast manner. The broadcast manner may include a MBSFN manner, or a cell broadcast manner, or broadcasting via a broadcast channel, or other broadcast manners. Or, the base station 1 may transmit the downlink V2X message via a unicast manner. Detailed implementation of step 1003 may vary with different manners for transmitting the downlink V2X message. If the downlink V2X message is transmitted via the MBSFN manner or the cell broadcast manner, step 1003 includes: the base station 1 transmits radio resource configuration information for the MBSFN to the UEs and transmits the downlink V2X message on the resources. If the downlink V2X message is broadcasted via the broadcast channel, step 1003 includes: the base station 1 directly transmits the downlink V2X message to the UEs via a newly-defined broadcast message. If the downlink V2X message is transmitted via other broadcast manners or the unicast manner, step 1003 may include configuring the radio resources for the broadcast or the unicast and transmitting the downlink V2X message on the configured resources.

[254] In step 1004, the base station 1 transmits V2X radio configuration information to the base station 2.

- [255] The base station 1 and the base station 2 have an overlapped coverage area or are adjacent base stations. The base station 1 belongs to operator 1 and the base station 2 belongs to operator 2. The base station 1 receives the uplink V2X message of the user and forwards the message to the V2X application layer service module. The V2X application layer service module generates a downlink V2X message and transmits the downlink V2X message to the base station 1. According to the configured information, the base station 1 knows that there is a base station 2 of operator 2 within its coverage. The base station 1 needs to transmit the V2X radio configuration information to UEs of the base station 2. The base station 1 and the base station 2 does not have an X2 interface. The base station 1 transmits the V2X radio configuration information to the base station 2 through the S1 interface. The base station 1 transmits an eNB configuration transfer message including the information of the destination base station and the V2X radio configuration information to the core network. The core network transmits an MME configuration transfer message including the V2X radio configuration information to the base station 2. The transmission within the core network may involve two MME nodes. The MME1 connected with the base station 1 finds the MME2 connected with the base station 2 according to the destination address in the message. Then MME1 transmits the message to the base station 2 via MME2.
- [256] In step 1005, the base station 2 transmits the V2X radio configuration information to UEs within the coverage of the base station 2.
- [257] The base station 2 receives from the base station 1 the configuration information of the radio resources allocated by the base station 1 for the downlink V2X message. The base station 2 transmits the V2X radio configuration information to the UEs via a broadcast manner or a unicast manner. The radio resource configuration information defines the radio resources configured by the base station 1 of operator 1. After receiving the configuration information, respective UE of operator 2 may receive the downlink V2X message on the corresponding resources at the corresponding time. For example, if the base station 1 and the base station 2 use the same frequency, the UE may receive the downlink V2X message broadcasted by the base station 1 on the corresponding resources at the corresponding time via a TDD manner. If the base station 1 and the base station 2 use different frequencies, in the case that the UE does not have the capability of operating on the two frequencies at the same time, the UE may switch to the frequency of the base station 1 to receive the downlink V2X message at the time of the V2X broadcast; in the case that the UE has the capability of operating on the two frequencies at the same time, the UE may enable the frequency of the base station 1 to receive the downlink V2X message at the time of the V2X broadcast.
- [258] Now, embodiment 8 is finished.
- [259] The above provides implementations of the method for transmitting V2X message.

Embodiments of the present disclosure also provide three apparatuses for transmitting V2X message, respectively for implementing the two implementation manners of the first method and the second method as described in the above embodiments.

[260] In accordance with the implementation manner 1 in the first method, the apparatus for transmitting V2X message includes: an uplink message receiver, a UE transmitter and a base station transmitter;

[261] the uplink message receiver is configured to receive an uplink V2X message transmitted by the UE; the UE transmitter is configured to transmit a downlink V2X message which is generated according to the uplink V2X message or configuration information for radio resources allocated by the present base station for the downlink V2X message to a second base station of an operator different from the operator of the present base station, wherein the second base station transmits the downlink V2X message or the configuration information for the radio resources to UEs within its coverage; wherein the configuration information for the radio resources is used by the UEs within the coverage of the second base station to receive the downlink V2X message on the resources indicated by the configuration information.

[262] In accordance with the above implementation manner 2 in the first method, the apparatus for transmitting V2X message includes: an uplink information receiver, a UE transmitter and a base station transmitter;

[263] the uplink message receiver is configured to receive from a base station connected with the apparatus an uplink V2X message transmitted by a UE within the coverage of the base station; the UE transmitter is configured to transmit via the base station connected with the apparatus a downlink V2X message which is generated based on the uplink V2X message to UEs within the coverage of the base station; the base station transmitter is configured to transmit the downlink V2X message to a second base station of another operator, wherein the second base station transmits the downlink V2X message to UEs within its coverage.

[264] In accordance with the second method, the apparatus for transmitting V2X message includes: a configuration information exchanging unit and a V2X configuration information transmitter;

[265] the configuration information exchanging unit is configured to exchange configuration information with a base station of an operator different from the operator of the present base station, the configuration information includes whether the base station has V2X capability and information about frequency which the base station transmits the V2X message; the V2X configuration information transmitter is configured to transmit, according to the exchanged configuration information, the V2X configuration information to UEs within its coverage, wherein the V2X configuration information includes the information about frequency for V2X message transmission

of a base station of another operator, such that the UEs receives the downlink V2X message of the base station of said another operator on the frequency.

[266] In order to support transmission of V2X service between base stations of different operators, there is still a problem to be solved. The V2X relevant message can be transmitted via the MBMS manner. However, in the existing MBMS message, Temporary Mobile Group Identity (TMGI) is used for identifying the MBMS service, whereas the TMGI consists of an operator identifier--PLMN (Public Land Mobile Network) ID and a unique identifier within the operator. It can be seen that, if the same downlink V2X message is broadcasted in different operators' networks, according to the definition of existing TMGI, the TMGIs used by different operators are different, which may lead to confusion for the UEs during the receiving. In order to solve this problem, there is a need to find a solution to configure the TMGI for different operators.

[267] The present disclosure provides three methods.

[268] Method 1:

[269] In this method, the base station 1 and the base station 2 belong to different operators. The downlink V2X message needs to be transmitted to the UEs within the coverage of the base station 1 and the base station 2. The base station 2 does not directly transmit the downlink V2X message to the UEs within its coverage. Instead, the UEs within the coverage of the base station 2 receive the downlink V2X message on the resources allocated by the base station 1 for the downlink V2X message. Based on this scenario, the TMGI may be configured as follows to ensure that the UEs within the coverage of the base station 2 can normally perform the downlink V2X message receiving.

[270] Step 1, negotiation is performed between operators of the base station 1 and the base station 2 to generate a TMGI mapping table.

[271] The base station transmits the mapping table to the UEs and the UEs store the mapping table. The mapping table may include {V2X service identifier, TMGI-1, TMGI-2}, wherein the V2X service identifier is optional, TMGI-1 is a service identifier of the operator 1 that the base station 1 belongs to, and TMGI-2 is a service identifier of the operator 2 that the base station 2 belongs to. The downlink V2X messages corresponding to the two identifiers are the same downlink V2X message.

[272] Step 2, the base station 1 broadcasts the downlink V2X message via an eMBMS bearer, and identifies the eMBMS bearer by TMGI-1.

[273] Step 3, the base station 1 transmits the V2X configuration information to the base station 2.

[274] The V2X configuration information may include the TMGI-1 used for the base station 1, the V2X radio resource configuration for the base station 1, and the V2X service identifier. The TMGI-1, the V2X radio resource configuration for the base

station 1 (e.g. the radio resource configuration information in the above embodiments 7 and 8) and the V2X service identifier are optional. The V2X configuration information may be transmitted via various manners, which is not restricted in the present disclosure. For example, the transmission manner for the radio resource configuration information in the foregoing embodiments 7 and 8 may be utilized.

[275] The base station 2 may adopt the following two manners to process the received V2X configuration information. In a first manner, if the V2X configuration information does not include the V2X service identifier, the V2X configuration information should include the TMGI-1 and the base station 2 needs to save the mapping table, such that the base station 2 can replace the TMGI-1 with TMGI-2 according to the mapping table and transmit the TMGI-2 to the UEs. In the second manner, if the V2X configuration information includes the V2X service identifier, the V2X configuration information may not include the TMGI-1, and the base station 2 may not save the mapping table and can directly transmit the V2X configuration information to the UEs.

[276] In accordance with the above first processing manner of the base station 2, the V2X configuration information does not include the V2X service identifier, the UEs receive the TMGI-2 and know that the TMGI-2 identifies a V2X service to be received by the UEs. According to the saved mapping table, the UEs are able to know that the base station 1 is broadcasting on the eMBMS bearer identified by TMGI-1. The UE may receive the data in the eMBMS bearer identified by the TMGI-1 via a TDD manner, so as to receive the downlink V2X message transmitted on the eMBMS bearer. If the V2X configuration information includes the radio resource configuration information for the base station 1, the UEs are able to directly receive on the resources indicated by the configuration information, the processing is not complicated. If the V2X configuration information does not include the radio resource configuration information for the base station 1, the UEs obtain the downlink V2X message on the eMBMS bearer identified by the TMGI-1 through receiving an eMBMS control message and user data transmitted by the base station 1.

[277] In accordance with the above second processing method for the base station 2, the V2X configuration information includes the V2X service identifier. The UEs receive the V2X service identifier and know according to the mapping relationship between the V2X service identifier and the TMGI-1 in the mapping table that the base station 1 is broadcasting on the eMBMS bearer identified by TMGI-1. The UEs may receive the data on the eMBMS bearer identified by TMGI-1 from the base station 1 in a TDD manner, so as to receive the downlink V2X message transmitted on the eMBMS bearer. If the V2X configuration information includes the radio resource configuration information for the base station 1, the UEs may directly receive on the resources indicated by the configuration information, the processing is not complicated. If the

V2X configuration information does not include the radio resource configuration information for the base station 1, the UEs obtain the downlink V2X message on the eMBMS bearer identified by the TMGI-1 through receiving an eMBMS control message and user data transmitted by the base station 1.

[278] The above solution is described from the view of the cooperation of multiple nodes. For respective UE, the processing includes:

[279] Step 1, a UE within the coverage of the base station 2 receives via the base station 2 the V2X configuration information transmitted by the base station 1.

[280] The V2X configuration information may include the TMGI-1 identifying the eMBMS bearer of the base station 1 and/or the V2X service identifier. If the V2X configuration information does not include the V2X service identifier, the base station 2 needs to save the mapping table. During the forwarding of the base station 2, the TMGI-1 is replaced by the TMGI-2 used by the base station 2 according to the mapping table.

[281] If the V2X configuration information includes the V2X service identifier, the base station 2 may not save the mapping table and may directly transmit the V2X configuration information to the UEs.

[282] Step 2, the UE determines, according to the received V2X configuration information and a local mapping table, that the base station 1 is broadcasting a downlink V2X message on the eMBMS bearer identified by the TMGI-1, and receives the downlink V2X message transmitted on the eMBMS bearer.

[283] The mapping table includes the mapping relationship between the V2X configuration information and the TMGI.

[284] Method 2:

[285] Similar as method 1, the base station 1 and the base station 2 belong to different operators and the downlink V2X message needs to be transmitted to the UEs in the coverage of the base station 1 and the base station 2. In this method, the base station 2 also needs to transmit the downlink V2X message. Based on this scenario, a TMGI configuration may be performed according to the following method, so as to ensure that the UEs within the coverage of the base station 2 can receive the downlink V2X message normally.

[286] Step 1, a negotiation is performed between operators of the base station 1 and the base station 2 to generate a TMGI mapping table.

[287] The mapping table is transmitted to a designated node of operator 1 that the base station 1 belongs to and a designated node of operator 2 that the base station 2 belongs to. The designated node may be a node of the access network or a node of the core network. For example, the mapping table may be transmitted to the base station 1 and the base station 2, or transmitted to BMSC, MBMS-GW and MCE in the eMBMS ar-

chitecture. The mapping table may include {V2X service identifier, TMGI-1, TMGI-2}, wherein the V2X service identifier is optional, TMGI-1 is a service identifier of the operator 1 that the base station 1 belongs to, and TMGI-2 is a service identifier of the operator 2 that the base station 2 belongs to. The downlink V2X messages corresponding to the two identifiers are the same downlink V2X message.

- [288] Step 2, the base station 1 broadcasts a downlink V2X message via an eMBMS bearer, and identifies the eMBMS bearer by TMGI-1.
- [289] Step 3, the base station 1 transmits the downlink V2X message to the base station 2. The node which receives the mapping table replaces the TMGI-1 before forwarding the downlink V2X message.
- [290] The base station 1 may transmit the downlink V2X message to the base station 2 via various manners, e.g., the downlink V2X message transmission manners provided in the above embodiments. During the transmission of the downlink V2X message, before forwarding the downlink V2X message, the node receiving the mapping table replaces the TMGI identifying the eMBMS bearer for the message. In particular, it replaces the TMGI-1 by the TMGI-2 according to the saved mapping table. For example, if step 708 in embodiment 7 is adopted, the MBMS-GW of operator 2 receives the session start message transmitted by the BMSC of operator 1, the MBMS-GW replaces the TMGI-1 by the TMGI-2 and then transmits the message to a next node. If the method as described in embodiment 8 is adopted, the base station 2 of operator 2 receives the session start message transmitted by the MCE of operator 1. The base station 2 replaces the TMGI-1 by the TMGI-2 and then transmits the message to the next node.
- [291] Thus, the downlink V2X message can be transmitted to the base station 2, and the eMBMS bearer identifier has been changed to the TMGI-2. The base station 2 can allocate radio resources for the downlink V2X message and identifies the corresponding eMBMS bearer by the TMGI-2. Since the TMGI has been changed to the TMGI-2 supported by the base station 2, the UEs within the coverage of the base station 2 can receive the downlink V2X message normally.
- [292] The solution of the above second method is described from the view of the cooperation of multiple nodes. For the designated node performing the TMGI replacement, the processing includes the following.
- [293] Step 1, the designated node X of the operator that the base station 1 or the base station 2 belongs to receives a downlink V2X message transmitted from the base station 1 to the base station 2.
- [294] The designated node X is an eMBMS forwarding node of the operator of the base station 1 for transmitting the V2X message to the base station 2. The base station 1 broadcasts the downlink V2X message via an eMBMS bearer.

- [295] Step 2, the designated node X replaces the TMGI-1 with which the base station 1 identifies the eMBMS bearer by the TMGI-2 used by the base station 2 according to a local mapping table, such that the UEs within the coverage of the base station 2 receive the downlink V2X message broadcasted by the base station 2.
- [296] The mapping table includes a mapping relationship between the TMGI of operator 1 and that of operator 2. The designated node X may be an eMBMS forwarding node of operator 1 or a forwarding node of operator 2. After receiving the downlink V2X message to be forwarded, the eMBMS forwarding node X replaces the TMGI-1 of the eMBMS bearer of operator 1 by the TMGI-2 used by the base station 2.
- [297] Step 3, the designated node X transmits the downlink V2X message to a next node after the replacement.
- [298] Method 3:
- [299] A dedicated TMGI is allocated for the V2X. This TMGI does not include an operator identifier. For the same V2X service, all operators use the same dedicated TMGI. Thus, the UEs are able to recognize the corresponding downlink V2X message via the identifier of the eMBMS bearer.
- [300] For the base station broadcasting the downlink V2X message, the processing includes the following.
- [301] Step 1, the base station receives an uplink V2X message reported by the UE.
- [302] Step 2, the base station broadcasts a downlink V2X message generated based on the uplink V2X message; wherein the downlink V2X message is broadcasted via an eMBMS bearer identified by the dedicated TMGI. The dedicated TMGI does not include the operator identifier and is allocated for the V2X in advance. For the same V2X service, all operators use the same dedicated TMGI.
- [303] In accordance with the above three TMGI configuring methods, the present disclosure provides corresponding apparatuses.
- [304] In accordance with the above method 1, an apparatus for receiving the V2X message provided by embodiments of the present disclosure includes: a configuration information receiver and a V2X receiver;
- [305] the configuration information receiver is configured to receive, via a second base station, V2X configuration information transmitted by a first base station; wherein the first base station broadcasts a downlink V2X message via an eMBMS bearer, the second base station belongs to an operator different from that of the first base station;
- [306] the V2X receiver is configured to determine, according to the received V2X configuration information and a local mapping table, that the first base station is broadcasting a downlink V2X message on the eMBMS bearer identified by a TMGI used by the operator of the first base station, and receive the downlink V2X message transmitted on the eMBMS bearer; wherein the mapping table includes a mapping rela-

relationship between the V2X configuration information and the TMGI.

- [307] In accordance with the processing manner of the designated node in the second method, embodiments of the present disclosure provide an apparatus for transmitting V2X message, applied in the designated node. The apparatus includes: a V2X receiver, a TMGI replacing unit and a V2X transmitter;
- [308] the V2X receiver is configured to receive a downlink V2X message transmitted by a first base station to a second base station; wherein the first base station broadcasts the downlink V2X message via an eMBMS bearer, the first base station and the second base station belong to different operators;
- [309] the TMGI replacing unit is configured to replace a TMGI-1 identifying the eMBMS bearer by the first base station with a TMGI-2 used by the second base station according to a local mapping table, such that UEs within the coverage of the second base station receive the downlink V2X message broadcasted by the second base station; wherein the mapping table includes a mapping relationship between the TMGI-1 of the operator of the first base station and the TMGI-2 of the operator of the second base station; and
- [310] the V2X transmitter is configured to transmit the downlink V2X message after the replacement.
- [311] In accordance with the processing of the base station in the above method 3, embodiments of the present disclosure provide an apparatus for transmitting V2X message, including a receiver and a broadcasting unit;
- [312] the receiver is configured to receive an uplink V2X message reported by a UE; and
- [313] the broadcasting unit is configured to broadcast a downlink V2X message generated according to the uplink V2X message; wherein the downlink V2X message is broadcasted on an eMBMS bearer identified by a dedicated TMGI, the dedicated TMGI is allocated for the V2X in advance and does not include an operator identifier, for the same V2X service, all operators use the same dedicated TMGI.
- [314] The foregoing are only preferred embodiments of the present disclosure and are not for use in limiting the protection scope of the present disclosure. Any modification, equivalent replacement and improvement made within the scope of the present disclosure should be covered under the protection scope of the present disclosure.
- [315] Furthermore, when defining a controller in the specification, it may be stated that "the controller may be a circuit, an application-specific integrated circuit or at least one processor."

[316]

[317]

[318]

[319]

Claims

- [Claim 1] A method for transmitting a vehicle to everything (V2X) message, comprising:
a first base station receiving an uplink V2X message transmitted by a user equipment (UE), and transmitting a downlink V2X message which is generated based on the uplink V2X message to UEs within coverage of the first base station;
the first base station transmitting the downlink V2X message or configuration information for radio resources allocated by the first base station for the downlink V2X message to a second base station of an operator different from an operator that the first base station belongs to, wherein the second base station transmits the downlink V2X message or the configuration information for the radio resources to UEs within coverage of the second base station; wherein the configuration information for the radio resources is used by the UEs within the coverage of the second base station to receive the downlink V2X message on resources indicated by the configuration information.
- [Claim 2] The method of claim 1, wherein the first base station transmits the downlink V2X message to the UEs within the coverage of the first base station via a broadcast manner; and/or
the second base station transmits the downlink V2X message to the UEs within the coverage of the second base station via a broadcast manner or a unicast manner.
- [Claim 3] The method of claim 1, wherein the first base station transmits the downlink V2X message to the UEs within the coverage of the first base station via a broadcast manner; and/or
the second base station transmits the downlink V2X message to the UEs within the coverage of the second base station via a broadcast manner or a unicast manner.
- [Claim 4] The method of claim 3, wherein the transmitting the downlink V2X message or the configuration information for the radio resources via the X2 interface between the base stations comprises: transmitting the downlink V2X message or the configuration information for the radio resources via a control plane or a user plane of the X2 interface; and wherein the transmitting the downlink V2X message or the configuration information for the radio resources via the S1 interface between the base stations comprises: the first base station transmitting

an eNB configuration transfer message to a core network, wherein the eNB configuration transfer message includes information of the second base station and the downlink V2X message or the configuration information for the radio resources; the core network transmitting the downlink V2X message or the configuration information for the radio resources to the second base station via a Mobility Management Entity (MME) configuration transfer message according to the received eNB configuration transfer message.

[Claim 5] The method of claim 1, wherein after receiving the configuration information for the radio resources, the second base station transmitting the downlink V2X message to the UEs within the coverage of the second base station via a broadcast manner or a unicast manner.

[Claim 6] A method for transmitting a vehicle to everything (V2X) message, comprising:
a V2X application layer service module connected with a first base station receiving via the first base station an uplink V2X message transmitted by a User Equipment (UE), and transmitting via the first base station a downlink V2X message which is generated based on the uplink V2X message to UEs within coverage of the first base station;
the V2X application layer service module connected with the first base station transmitting the downlink V2X message to a second base station of an operator different from an operator that the first base station belongs to, wherein the second base station transmits the downlink V2X message to UEs within coverage of the second base station.

[Claim 7] The method of claim 6, wherein the V2X application layer service module transmits the downlink V2X message to the UEs within the coverage of the first base station via the first base station through a broadcast manner or a unicast manner; and/or,
the second base station transmits the downlink V2X message to the UEs within the coverage of the second base station through the broadcast manner or the unicast manner.

[Claim 8] The method of claim 6, wherein the downlink V2X message is transmitted to the second base station via an interface between the V2X application layer service module connected with the first base station and a V2X application layer service module connected with the second base station; or, the downlink V2X message is transmitted to the second base station via an interface between the V2X application layer service module connected with the first base station and the second

base station; or, the downlink V2X message is transmitted to the second base station via an interface between an enhanced Multimedia Broadcast/Multicast Service (eMBMS) node of the first base station and an eMBMS node of the second base station; or, the downlink V2X message is transmitted to the second base station via an interface between a Multi-cell/multicast Coordination Entity (MCE) for the eMBMS of the first base station and the second base station.

[Claim 9]

The method of claim 8, wherein the V2X application layer service module transmitting the generated downlink V2X message to the first base station comprises: the V2X application layer service module forwarding the downlink V2X message to the first base station via a Broadcast Multicast Service Center (BMSC), an MBMS gateway (MBMS-GW), an MME and an MCE of the operator that the first base station belongs to;

the transmitting the downlink V2X message via the interface between the eMBMS node for the first base station and the eMBMS node for the second base station comprises:

the V2X application layer service module connected with the first base station transmitting the downlink V2X message to the BMSC of the operator of the first base station, the BMSC transmitting the downlink V2X message to the MCE of the operator of the second base station via the MBMS-GW and the MME of the operator of the second base station; or, the V2X application layer service module connected with the first base station transmitting the downlink V2X message to the BMSC of the operator of the first base station, the BMSC forwarding the downlink V2X message to the MCE of the operator of the second base station via the MBMS-GW and the MME of the operator of the first base station, and the MCE is used for forwarding the downlink V2X message to the second base station.

[Claim 10]

The method of claim 8, wherein the V2X application layer service module transmitting the generated downlink V2X message to the first base station comprises: the V2X application layer service module forwarding the downlink V2X message to the first base station via the BMSC, the MBMS-GW and the MME of the operator of the first base station;

the transmitting the downlink V2X message via the interface between the MCE of the first base station and the second base station comprises: the V2X application layer service module connected with the first base

station transmitting the downlink V2X message to the BMSC of the operator of the first base station, the BMSC transmitting the downlink V2X message to the MCE of the operator of the first base station via the MBMS-GW and the MME of the operator of the first base station, wherein the MCE forwards the downlink V2X message to the second base station via the interface between the MCE and the second base station established in advance.

[Claim 11]

A method for transmitting a vehicle to everything (V2X) message, comprising:

a first base station having a V2X capability exchanging configuration information with a base station of another operator different from that of the first base station, the configuration information comprises whether the base station has the V2X capability and frequency information for V2X message transmission of the base station; according to the exchanged configuration information, the first base station transmitting V2X configuration information to UEs within coverage of the first base station, wherein the V2X configuration information comprises information about frequency for V2X message transmission of the base station of the another operator, the UEs receive the downlink V2X message of the base station of the another operator on the frequency.

[Claim 12]

The method of claim 11, wherein the V2X configuration information exchanged between different base stations is transmitted via an X2 interface or an S1 interface between the base stations; and wherein the V2X configuration information further comprises information about frequency for the downlink V2X message transmission of the first base station.

[Claim 13]

A method for receiving a vehicle to everything (V2X) message, comprising:

a User Equipment (UE) within coverage of a second base station receiving via the second base station V2X configuration information transmitted by a first base station, wherein the first base station broadcasts a downlink V2X message via an enhanced Multimedia Broadcast Multimedia Service (eMBMS) bearer, the second base station belongs to an operator different from the first base station; the UE determining according to the received V2X configuration information and a local mapping table that the first base station broadcasts the downlink V2X message on the eMBMS bearer identified

by a Temporary Mobile Group Identity (TMGI), and receiving the downlink V2X message transmitted via the eMBMS bearer, wherein the mapping table comprises a mapping relationship between the V2X configuration information and the TMGI.

[Claim 14]

The method of claim 13, wherein the mapping table comprises a mapping relationship between TMGI-1 of the operator of the first base station and TMGI-2 of the operator of the second base station, the mapping table is saved in the second base station; the V2X configuration information comprises the TMGI-1 used by the first base station for identifying the eMBMS bearer, and during forwarding, the TMGI-1 is replaced by the second base station with the TMGI-2 used by the second base station according to the mapping table.

[Claim 15]

The method of claim 13, wherein the mapping table comprises a mapping relationship between the TMGI-1 of the operator of the first base station and a V2X service identifier, the V2X configuration information comprises the V2X service identifier; the UE determining that the first base station broadcasts the downlink V2X message on the eMBMS bearer identified by the TMGI-1 according to the received V2X configuration information and the mapping relationship between the V2X service identifier and the TMGI-1.

[Fig. 1]

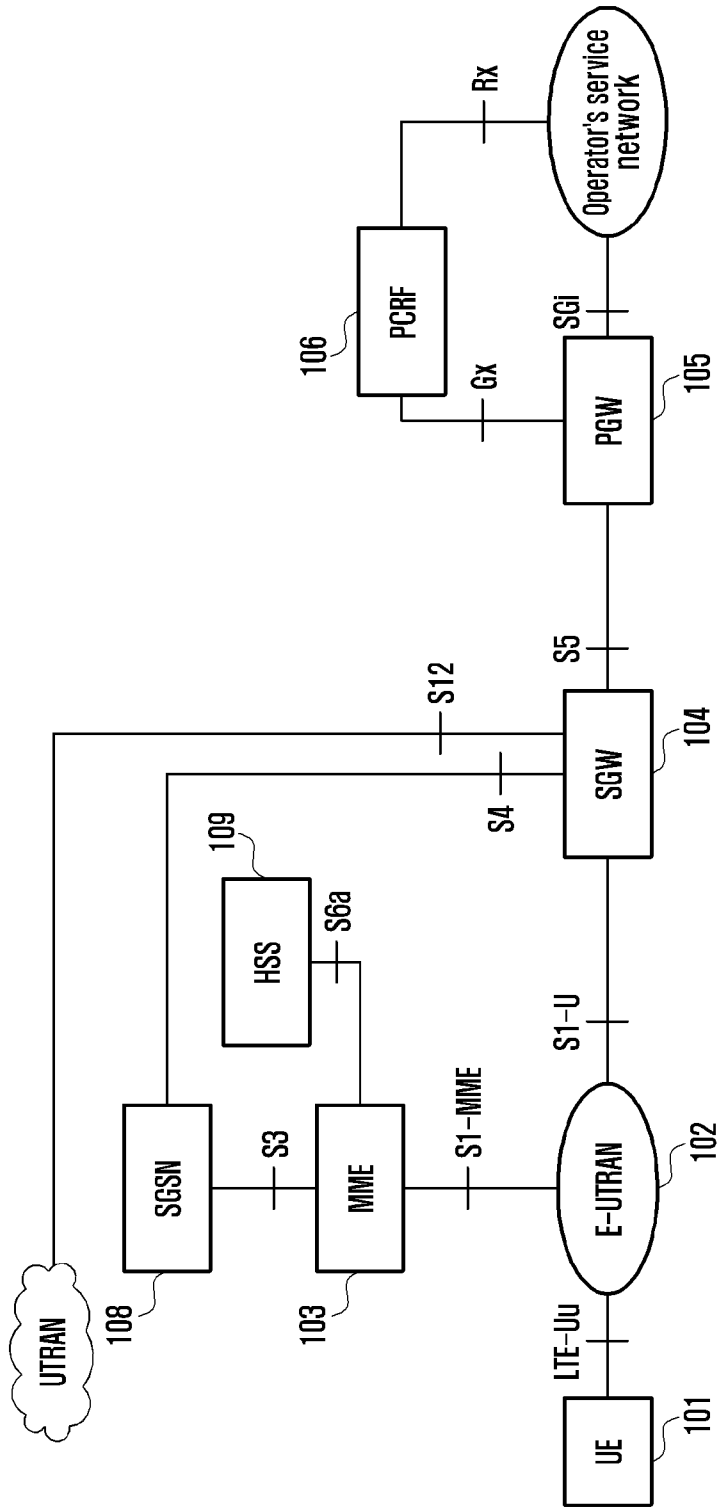

[Fig. 2]

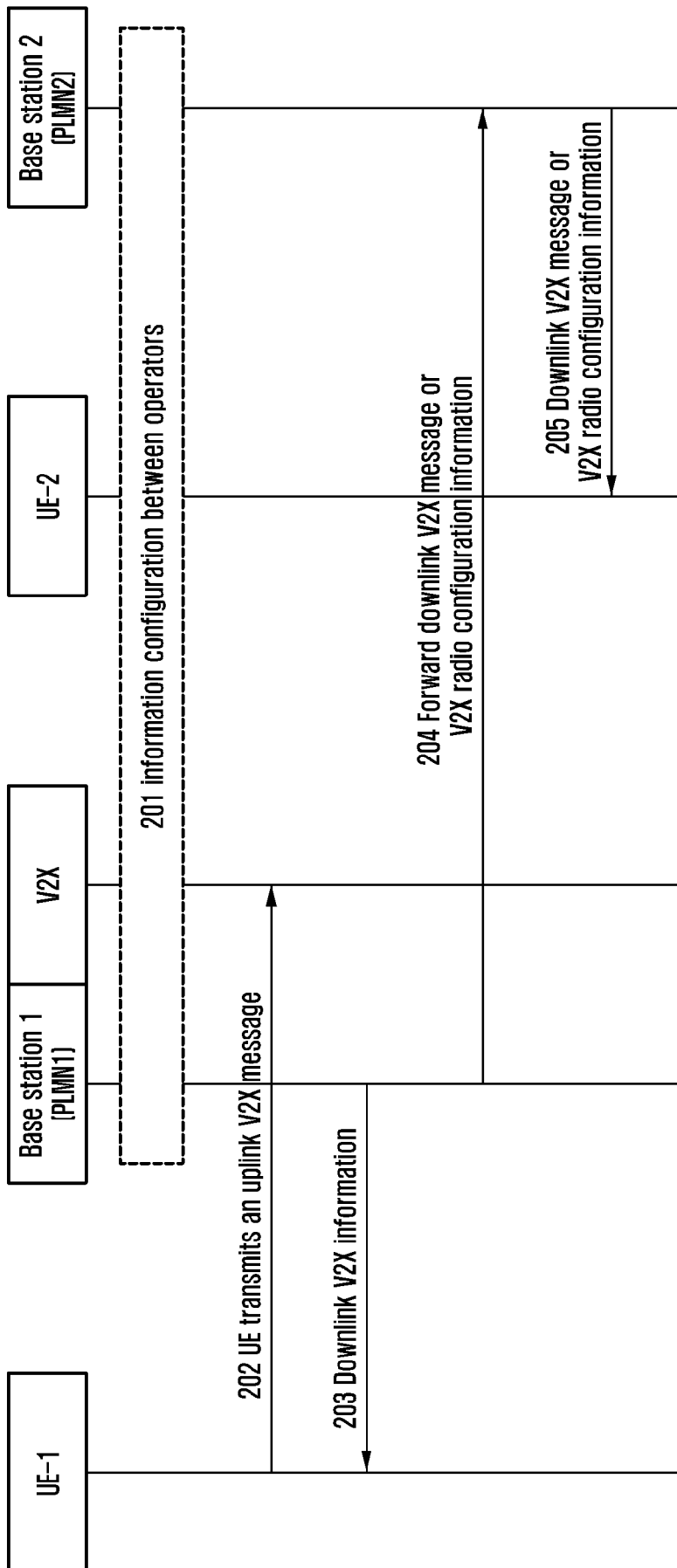

[Fig. 3]

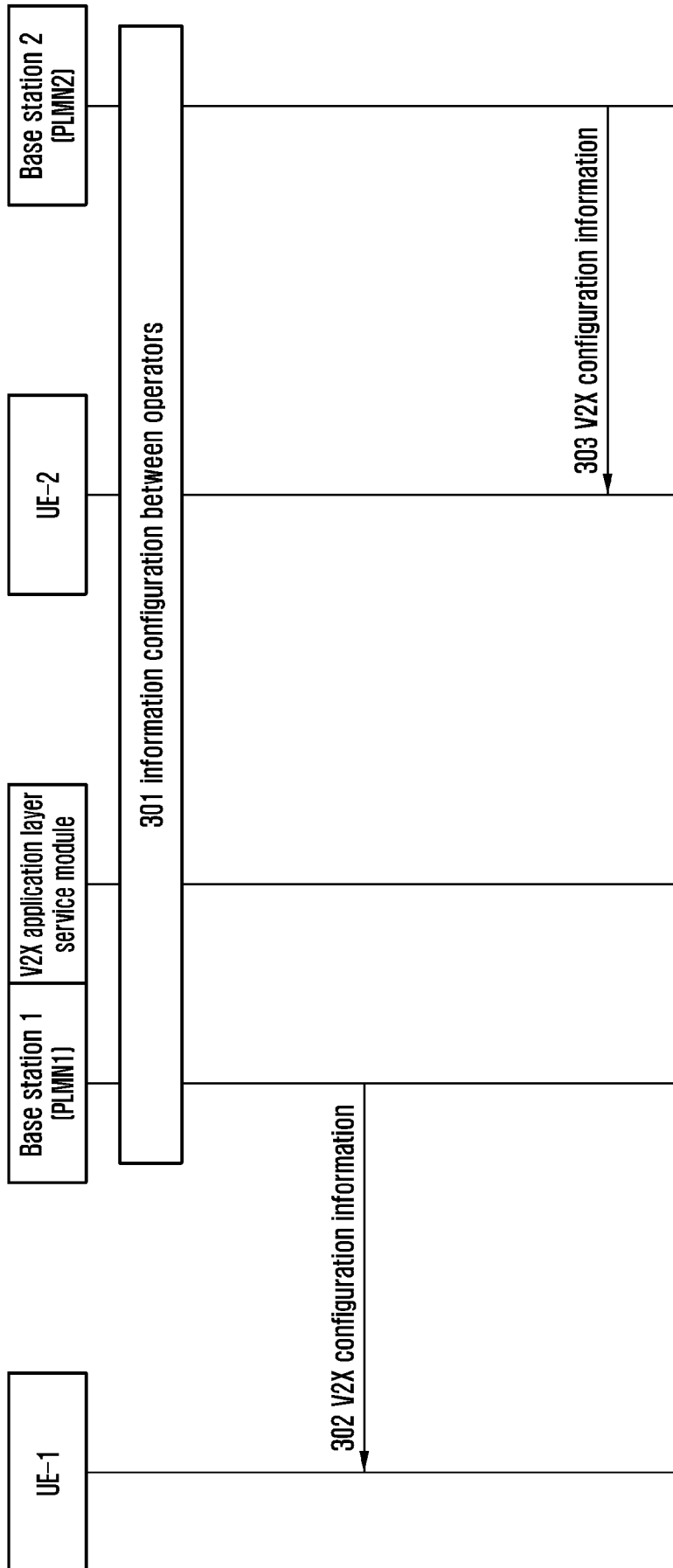

[Fig. 4]

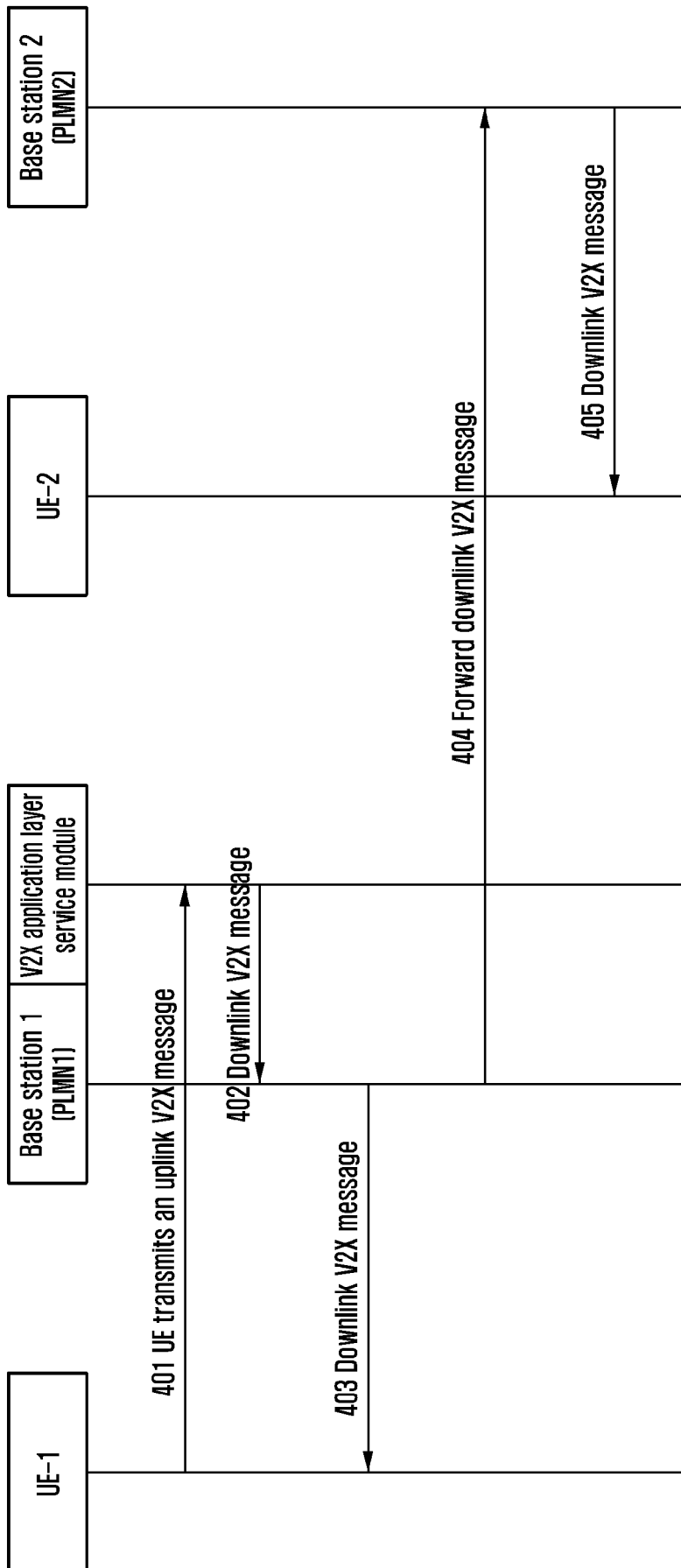

[Fig. 5]

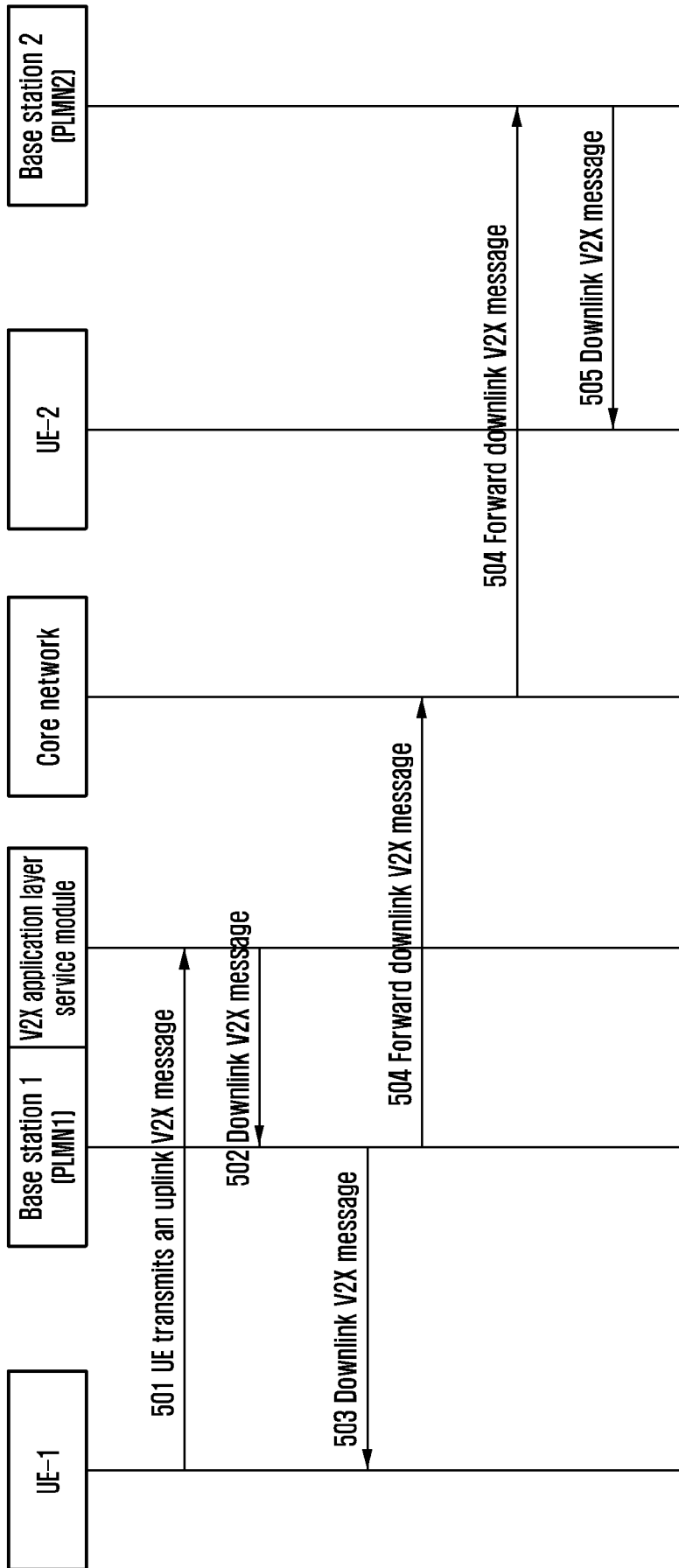

[Fig. 6]

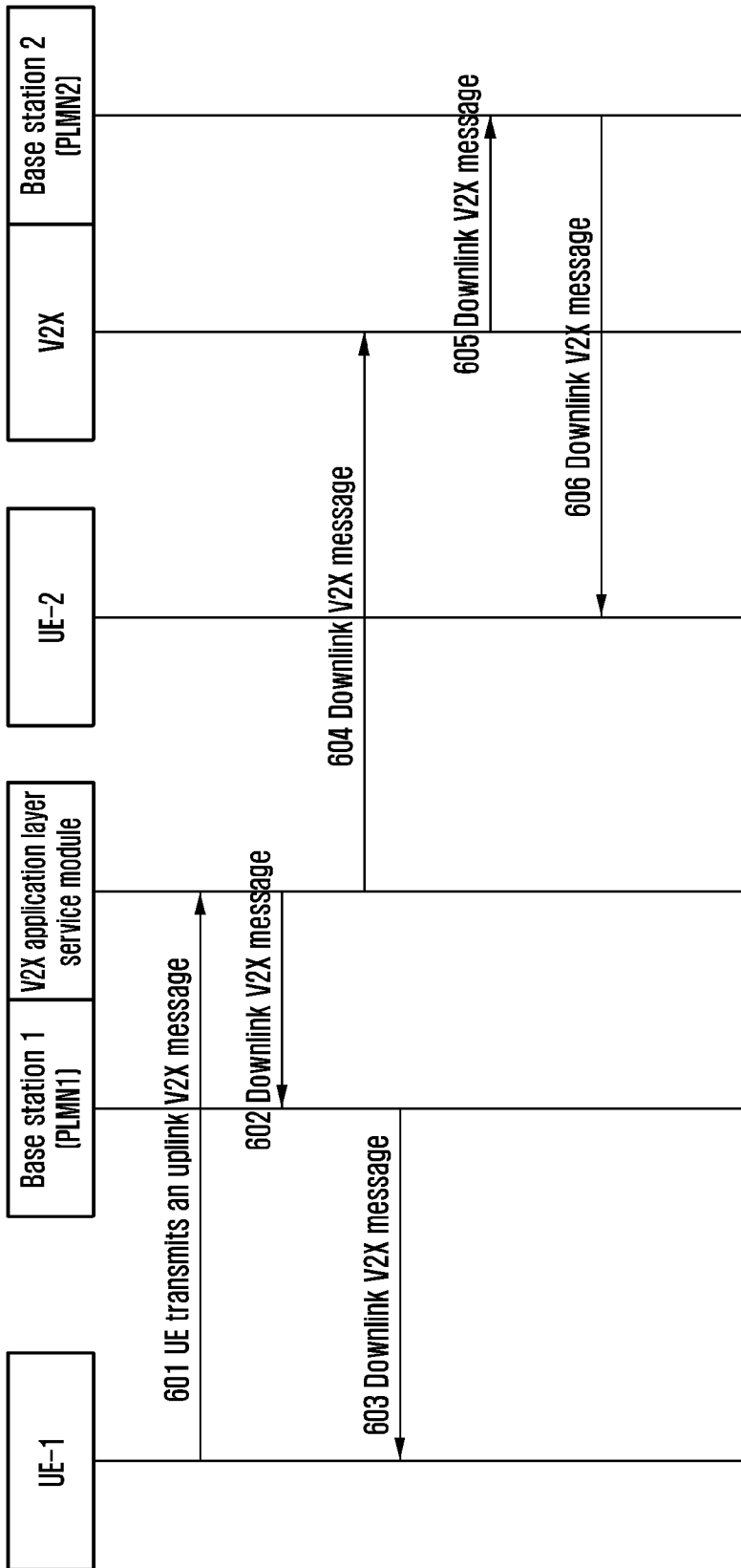

[Fig. 7]

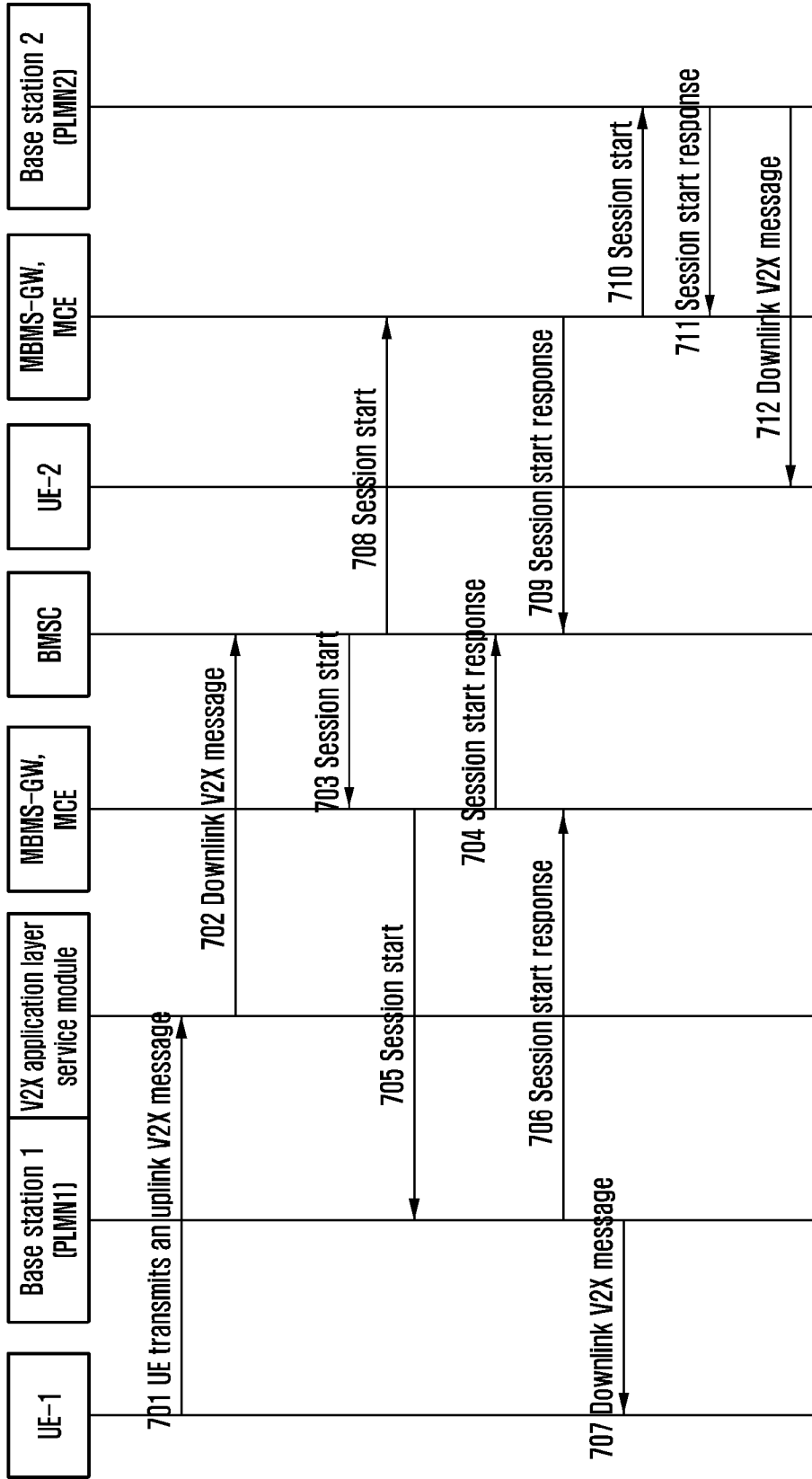

[Fig. 8]

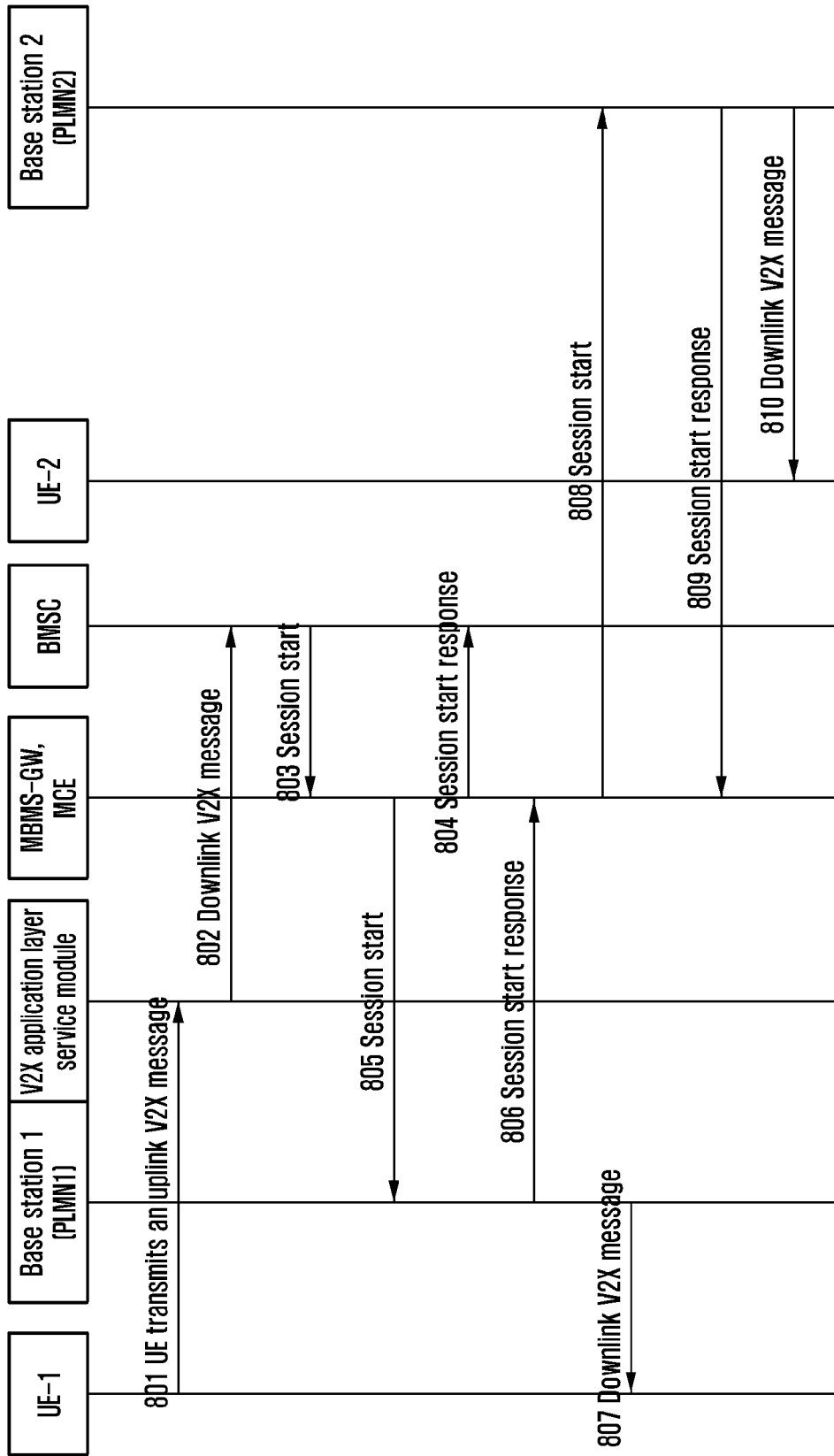

[Fig. 9]

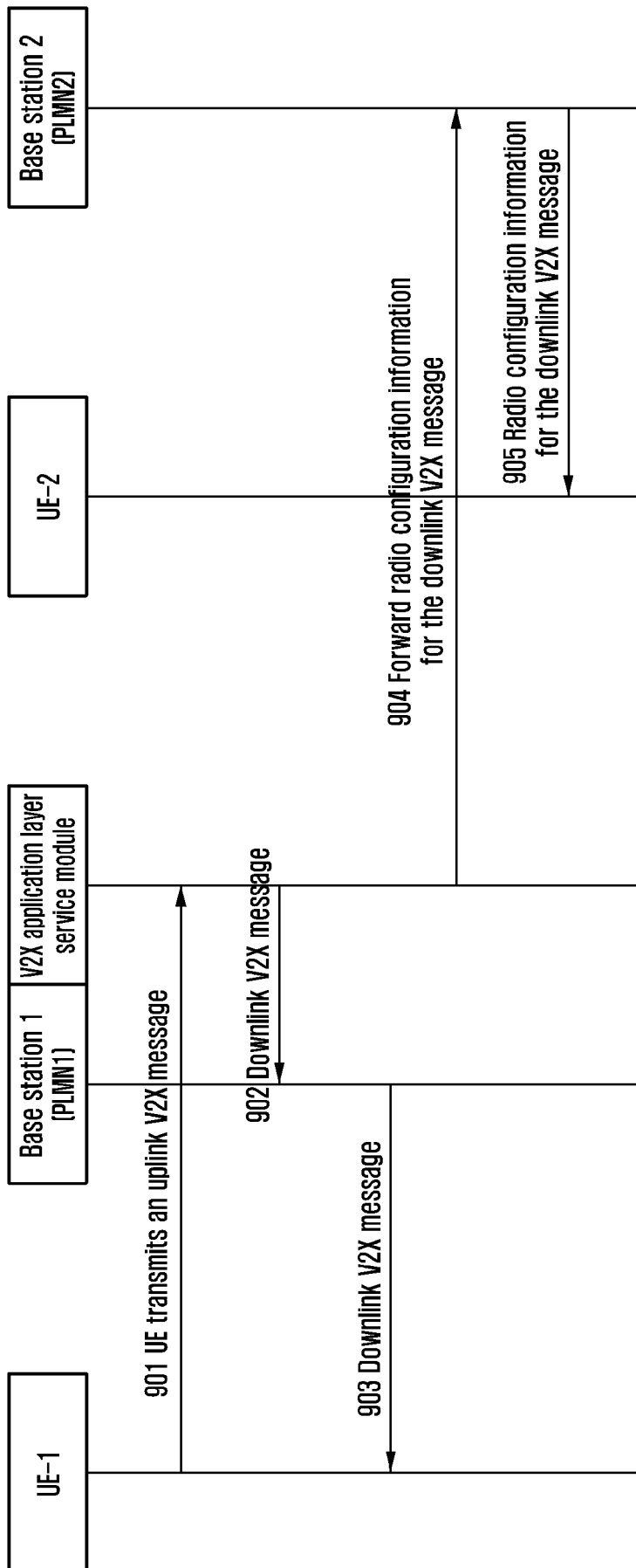

[Fig. 10]

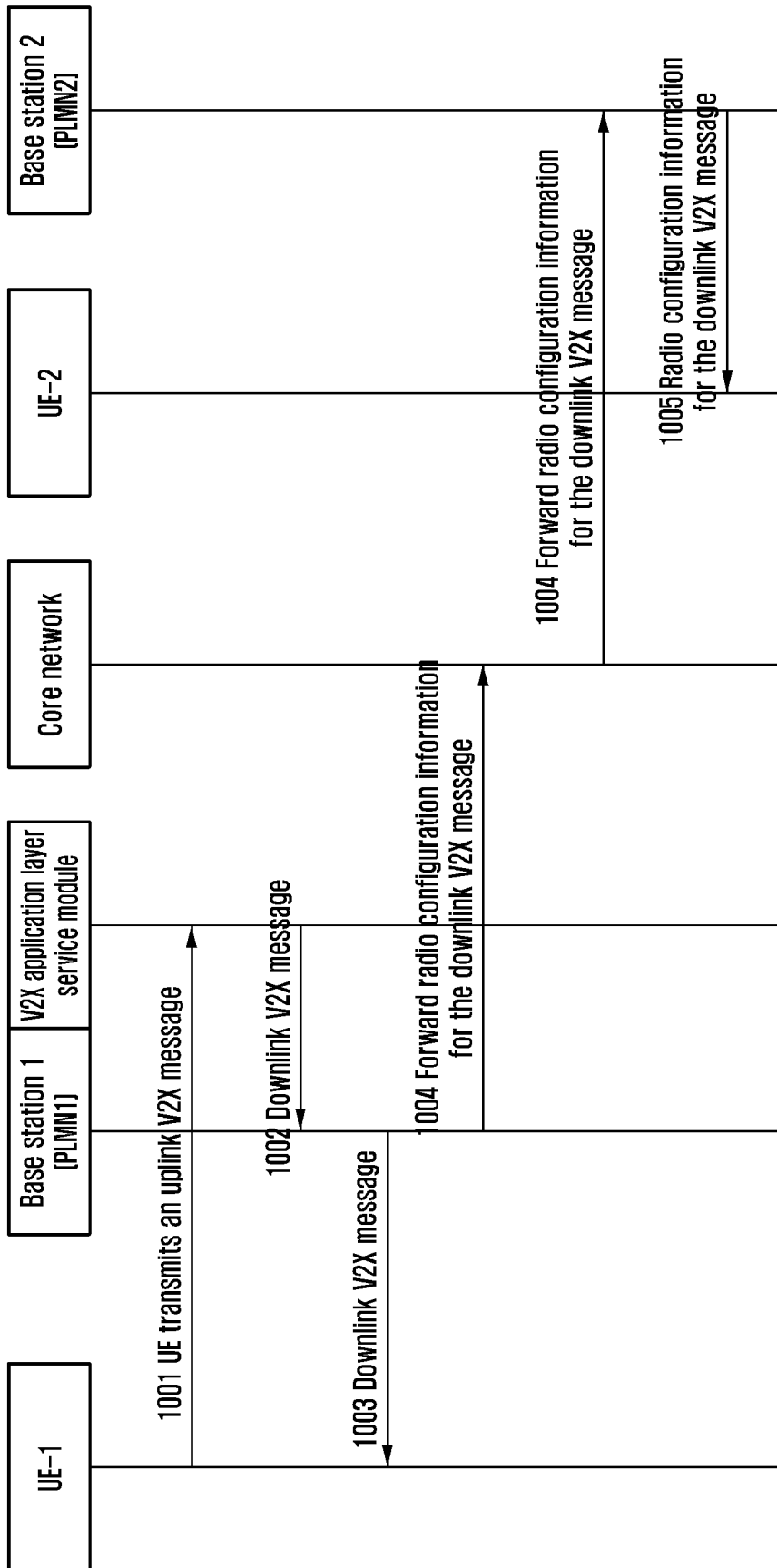

INTERNATIONAL SEARCH REPORT

International application No.
PCT/KR2017/000275**A. CLASSIFICATION OF SUBJECT MATTER****H04W 72/04(2009.01)i, H04W 4/00(2009.01)i, H04W 4/06(2009.01)i, H04W 92/10(2009.01)i, H04W 92/20(2009.01)i**

According to International Patent Classification (IPC) or to both national classification and IPC

B. FIELDS SEARCHED

Minimum documentation searched (classification system followed by classification symbols)

H04W 72/04; H04W 4/22; H04W 36/00; H04W 76/04; H04W 4/00; H04W 4/06; H04W 92/10; H04W 92/20

Documentation searched other than minimum documentation to the extent that such documents are included in the fields searched

Korean utility models and applications for utility models

Japanese utility models and applications for utility models

Electronic data base consulted during the international search (name of data base and, where practicable, search terms used)

eKOMPASS(KIPO internal) & Keywords: V2X, second base station, different operator, configuration information, V2X application layer service module, capability exchange

C. DOCUMENTS CONSIDERED TO BE RELEVANT

Category*	Citation of document, with indication, where appropriate, of the relevant passages	Relevant to claim No.
X	LG ELECTRONICS, `Key issues for V2I`, S2-153893, 3GPP SA WG2 Meeting #112, 12 November 2015 See sections 1, 5.3.n.1; and table 2.	6
Y		1-5, 7-15
Y	NGOC-DUY NGUYEN et al., `Service Continuity for eMBMS in LTE/LTE-Advanced Network: Standard Analysis and Supplement`, Consumer Communications and Networking Conference(CCNC), 2014 IEEE 11th, 28 July 2014 (URL: http://www.eurecom.fr/fr/publication/4193/download/cm-publi-41d3.pdf) See pages 3 - 5; and figure 4.	1-5, 11-15
Y	3GPP TR 23.768 v12.1.0, `3GPP; TSGSSA; Study on architecture enhancements to support Group Communication System Enablers for LTE(GCSE_LTE) (Release 12)`, 24 June 2014 See sections 6.1.1.2 - 6.4.2.2.1; and figures 6.1.1.2-1 - 6.3.2.2-1.	7-10, 14-15
A	WO 2014-173429 A1 (TELEFONAKTIEBOLAGET L M ERICSSON (PUBL)) 30 October 2014 See page 4, line 36 - page 8, line 18.	1-15
A	US 2012-0134336 A1 (YUUTA NAKAYA et al.) 31 May 2012 See claim 1; and figures 2, 4.	1-15

 Further documents are listed in the continuation of Box C. See patent family annex.

* Special categories of cited documents:

"A" document defining the general state of the art which is not considered to be of particular relevance

"E" earlier application or patent but published on or after the international filing date

"L" document which may throw doubts on priority claim(s) or which is cited to establish the publication date of another citation or other special reason (as specified)

"O" document referring to an oral disclosure, use, exhibition or other means

"P" document published prior to the international filing date but later than the priority date claimed

"T" later document published after the international filing date or priority date and not in conflict with the application but cited to understand the principle or theory underlying the invention

"X" document of particular relevance; the claimed invention cannot be considered novel or cannot be considered to involve an inventive step when the document is taken alone

"Y" document of particular relevance; the claimed invention cannot be considered to involve an inventive step when the document is combined with one or more other such documents, such combination being obvious to a person skilled in the art

"&" document member of the same patent family

Date of the actual completion of the international search

21 April 2017 (21.04.2017)

Date of mailing of the international search report

21 April 2017 (21.04.2017)

Name and mailing address of the ISA/KR

International Application Division
Korean Intellectual Property Office
189 Cheongsa-ro, Seo-gu, Daejeon, 35208, Republic of Korea

Facsimile No. +82-42-481-8578

Authorized officer

KANG, Hee Gok

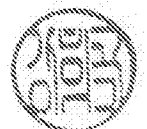

Telephone No. +82-42-481-8264

INTERNATIONAL SEARCH REPORT

Information on patent family members

International application No.

PCT/KR2017/000275

Patent document cited in search report	Publication date	Patent family member(s)	Publication date
WO 2014-173429 A1	30/10/2014	CN 105165058 A EP 2989824 A1 JP 2016-521055A US 2016-0073298 A1	16/12/2015 02/03/2016 14/07/2016 10/03/2016
US 2012-0134336 A1	31/05/2012	JP 5440601 B2 US 8477751 B2 WO 2010-113219 A1	12/03/2014 02/07/2013 07/10/2010