



- (51) **International Patent Classification:**
E21B 10/46 (2006.01) *E21B 10/567* (2006.01)
- (21) **International Application Number:**
PCT/US2012/055001
- (22) **International Filing Date:**
13 September 2012 (13.09.2012)
- (25) **Filing Language:** English
- (26) **Publication Language:** English
- (30) **Priority Data:**
61/535,766 16 September 2011 (16.09.2011) US
- (71) **Applicant (for all designated States except US):** **BAKER HUGHES INCORPORATED** [US/US]; P.O. Box 4740, Houston, TX 77210-4740 (US).
- (72) **Inventors; and**
- (75) **Inventors/Applicants (for US only):** **DIGIVANNI, Anthony, A.** [US/US]; 8910 Opper Ln., Houston, TX 77064 (US). **PESSIER, Rudolf, Carl** [US/US]; 505 Jackson Hill #409, Houston, TX 77007 (US).
- (74) **Agents:** **WELBORN, Brian, S.** et al.; Baker Hughes Incorporated, Intellectual Property Counsel, P.O. Box 4740, Houston, TX 77210-4740 (US).
- (81) **Designated States (unless otherwise indicated, for every kind of national protection available):** AE, AG, AL, AM,

AO, AT, AU, AZ, BA, BB, BG, BH, BN, BR, BW, BY, BZ, CA, CH, CL, CN, CO, CR, CU, CZ, DE, DK, DM, DO, DZ, EC, EE, EG, ES, FI, GB, GD, GE, GH, GM, GT, HN, HR, HU, ID, IL, IN, IS, JP, KE, KG, KM, KN, KP, KR, KZ, LA, LC, LK, LR, LS, LT, LU, LY, MA, MD, ME, MG, MK, MN, MW, MX, MY, MZ, NA, NG, NI, NO, NZ, OM, PA, PE, PG, PH, PL, PT, QA, RO, RS, RU, RW, SC, SD, SE, SG, SK, SL, SM, ST, SV, SY, TH, TJ, TM, TN, TR, TT, TZ, UA, UG, US, UZ, VC, VN, ZA, ZM, ZW.

- (84) **Designated States (unless otherwise indicated, for every kind of regional protection available):** ARIPO (BW, GH, GM, KE, LR, LS, MW, MZ, NA, RW, SD, SL, SZ, TZ, UG, ZM, ZW), Eurasian (AM, AZ, BY, KG, KZ, RU, TJ, TM), European (AL, AT, BE, BG, CH, CY, CZ, DE, DK, EE, ES, FI, FR, GB, GR, HR, HU, IE, IS, IT, LT, LU, LV, MC, MK, MT, NL, NO, PL, PT, RO, RS, SE, SI, SK, SM, TR), OAPI (BF, BJ, CF, CG, CI, CM, GA, GN, GQ, GW, ML, MR, NE, SN, TD, TG).

Declarations under Rule 4.17:

- *as to applicant's entitlement to apply for and be granted a patent (Rule 4.17(ii))*

Published:

- *without international search report and to be republished upon receipt of that report (Rule 48.2(g))*



WO 2013/040125 A2

(54) **Title:** CUTTING ELEMENTS FOR EARTH-BORING TOOLS, EARTH-BORING TOOLS INCLUDING SUCH CUTTING ELEMENTS AND RELATED METHODS

(57) **Abstract:** Cutting elements, earth-boring drill bits having such cutting elements and related methods are described herein. In some embodiments, a cutting element for an earth-boring tool may include a superabrasive table having a recessed surface in a cutting face thereof and a shaped feature in a substrate at the interface between the superabrasive table and the substrate, the shaped feature corresponding to the recessed surface in the cutting face of the superabrasive table. In further embodiments, a cutting element for an earth-boring tool may comprise a superabrasive table positioned on a substrate, and at least one substantially planar recessed surface in a cutting face of the superabrasive table. In yet additional embodiments, a cutting element for an earth-boring tool may comprise a superabrasive table positioned on a substrate, and at least one non-planar recessed surface in a cutting face of the superabrasive table.

TITLE

CUTTING ELEMENTS FOR EARTH-BORING TOOLS, EARTH-BORING TOOLS INCLUDING SUCH CUTTING ELEMENTS AND RELATED METHODS

5

CROSS-REFERENCE TO RELATED APPLICATION

[0001] This application claims the benefit of U.S. Provisional Patent Application Serial No. 61/535,766, filed September 16, 2011, entitled "Cutting Elements for Earth-Boring Tools, Earth-Boring Tools Including Such Cutting Elements and Related Methods," the disclosure of which is incorporated herein by reference in its entirety.

10

TECHNICAL FIELD

[0002] Embodiments of the present disclosure relate to earth-boring tools, cutting elements for such earth-boring tools, and related methods.

15

BACKGROUND

[0003] Wellbores are formed in subterranean formations for various purposes including, for example, extraction of oil and gas from the subterranean formation and extraction of geothermal heat from the subterranean formation. Wellbores may be formed in a subterranean formation using a drill bit such as, for example, an earth-boring rotary drill bit. Different types of earth-boring rotary drill bits are known in the art including, for example, fixed-cutter bits (which are often referred to in the art as "drag" bits), rolling-cutter bits (which are often referred to in the art as "rock" bits), diamond-impregnated bits, and hybrid bits (which may include, for example, both fixed cutters and rolling cutters). The drill bit is rotated and advanced into the subterranean formation. As the drill bit rotates, the cutters or abrasive structures thereof cut, crush, shear, and/or abrade away the formation material to form the wellbore. A diameter of the wellbore drilled by the drill bit may be defined by the cutting structures disposed at the largest outer diameter of the drill bit.

20

25

[0004] The drill bit is coupled, either directly or indirectly, to an end of what is referred to in the art as a "drill string," which comprises a series of elongated tubular segments connected end-to-end that extends into the wellbore from the surface of the formation. Often various tools and components, including the drill bit, may be coupled together at the distal end

30

of the drill string at the bottom of the wellbore being drilled. This assembly of tools and components is referred to in the art as a "bottom-hole assembly" (BHA).

[0005] The drill bit may be rotated within the wellbore by rotating the drill string from the surface of the formation, or the drill bit may be rotated by coupling the drill bit to a
5 downhole motor, which is also coupled to the drill string and disposed proximate the bottom of the wellbore. The downhole motor may comprise, for example, a hydraulic Moineau-type motor having a shaft, to which the drill bit is mounted, that may be caused to rotate by pumping fluid (*e.g.*, drilling mud or fluid) from the surface of the formation down through the center of the drill string, through the hydraulic motor, out from nozzles in the drill bit, and back up to the
10 surface of the formation through the annular space between the outer surface of the drill string and the exposed surface of the formation within the wellbore.

BRIEF SUMMARY

[0006] In some embodiments, a cutting element for an earth-boring tool may comprise
15 a superabrasive table positioned on a substrate, and at least one substantially planar recessed surface in a cutting face of the superabrasive table.

[0007] In further embodiments, an earth-boring tool may comprise at least one cutting element. The at least one cutting element may include a superabrasive table having a recessed surface in a cutting face thereof and a shaped feature in a substrate at the interface between the
20 superabrasive table and the substrate, the shaped feature corresponding to the recessed surface in the cutting face of the superabrasive table.

[0008] In additional embodiments, an earth-boring tool may comprise at least one a cutting element. The at least one cutting element comprising a superabrasive table positioned on a substrate, and at least one substantially planar recessed surface in a cutting face of the
25 superabrasive table.

[0009] In yet further embodiments, an earth-boring tool may comprise at least one cutting element. The at least one cutting element may include a superabrasive table positioned on a substrate; and a plurality of non-planar recessed surfaces in a cutting face of the superabrasive table.

[0010] In yet other embodiments, an earth-boring tool may comprise at least one blade and a plurality of cutting elements. Each cutting element of the plurality of cutting elements may include a superabrasive table positioned on a substrate; and at least one recessed surface in a cutting face of the superabrasive table. At least one cutting element of the plurality of cutting elements is affixed to one or more of a cone, nose, shoulder, and gage region of the at least one blade.

BRIEF DESCRIPTION OF THE DRAWINGS

[0011] While the specification concludes with claims particularly pointing out and distinctly claiming what are regarded as embodiments of the present disclosure, various features and advantages of this disclosure may be more readily ascertained from the following description of example embodiments of the disclosure provided with reference to the accompanying drawings.

[0012] FIG. 1 is a perspective view of an earth-boring drill bit including cutting elements, according to an embodiment of the present disclosure.

[0013] FIG. 2 is a partially cut-away side view of a cutting element having a recessed surface in a cutting face according to an embodiment of the present disclosure.

[0014] FIG. 3 is a perspective view of the cutting element of FIG. 2.

[0015] FIG. 4 is a perspective view of a cutting element including a recessed surface having a generally circular shape, according to an embodiment of the present disclosure.

[0016] FIG. 5 is a plan view of the cutting element shown in FIG. 4.

[0017] FIG. 6 is a plan view of a cutting element including a recessed surface having a generally square shape, according to an embodiment of the present disclosure.

[0018] FIG. 7 is a plan view of a cutting element including a recessed surface having a generally square shape and a central island or protrusion, according to an embodiment of the present disclosure.

[0019] FIG. 8 is a plan view of a cutting element including a recessed surface having a generally pentagonal shape, according to an embodiment of the present disclosure.

[0020] FIG. 9 is a plan view of a cutting element including a recessed surface having a generally pentagonal shape and a central island or protrusion, according to an embodiment of the present disclosure.

[0021] FIG. 10 is a plan view of a cutting element including a recessed surface shaped generally as a Reuleaux polygon, according to an embodiment of the present disclosure.

[0022] FIG. 11 is a perspective view of a cutting element including a plurality of recessed surfaces having a generally circular shape and arranged in a generally annular configuration, according to an embodiment of the present disclosure.

[0023] FIG. 12 is a plan view of the cutting element of FIG. 11.

[0024] FIG. 13 is a plan view of a cutting element including a plurality of recessed surfaces having a generally circular shape and arranged in a generally circular configuration, according to an embodiment of the present disclosure.

[0025] FIG. 14 is a plan view of a cutting element including a plurality of recessed surfaces having a generally circular shape and arranged proximate to an intended cutting edge, according to an embodiment of the present disclosure.

[0026] FIG. 15 is a plan view of a cutting element including a plurality of recessed surfaces having a generally polygonal shape and arranged in a generally annular configuration, according to an embodiment of the present disclosure.

[0027] FIG. 16 is a plan view of a cutting element including a plurality of recessed surfaces having a generally polygonal shape and arranged in a generally circular configuration, according to an embodiment of the present disclosure.

[0028] FIG. 17 is a plan view of a cutting element including a plurality of recessed surfaces having a generally polygonal shape and arranged proximate to an intended cutting edge, according to an embodiment of the present disclosure.

[0029] FIG. 18 is a perspective view of a cutting element including a plurality of recessed surfaces having a generally polygonal shape and arranged in a generally annular configuration, according to an embodiment of the present disclosure.

[0030] FIG. 19 is a cross-sectional side view of a cutting element having three (3) arcuate-shaped cross-sectional recessed surfaces formed in the cutting face the cutting element, according to an embodiment of the present disclosure.

[0031] FIG. 20 is a plan view of the cutting element of FIG. 19, illustrating the annular, concentric, symmetrical orientation of the recessed surfaces, according to an embodiment of the present disclosure.

[0032] FIG. 21 is a plan view of a cutting element having six (6) arcuate-shaped cross-sectional recessed surfaces formed in the cutting face of the cutting element illustrating the

annular, concentric, symmetrical orientation of the recessed surfaces, according to an embodiment of the present disclosure.

[0033] FIG. 22 is a cross-sectional side view of a portion of a superabrasive table of a cutting element having three (3) chevron-shaped cross-sectional recessed surfaces formed in a cutting face of the cutting element, according to an embodiment of the present disclosure.

[0034] FIG. 23 is a cross-sectional view of a portion of a superabrasive table of a cutting element having a recessed surface substantially filled with a sacrificial structure, according to an embodiment of the present disclosure.

[0035] FIG. 24 is a cross-sectional view of a portion of a superabrasive table of a cutting element with a relatively thin sacrificial structure positioned over a surface of a recessed surface, according to an embodiment of the present disclosure.

[0036] FIG. 25 is a cross-sectional view of a portion of a cutting element with a shaped region at an interface between a superabrasive table and a substrate corresponding to a shape of a recessed surface in a cutting face of the superabrasive table, according to an embodiment of the present disclosure.

[0037] FIG. 26 is a cross-sectional view of a portion of a cutting element with a shaped region at an interface between a superabrasive table and a substrate corresponding to a shape of a recessed surface in a cutting face of the superabrasive table positioned radially outward of the recessed surface, according to an embodiment of the present disclosure.

[0038] FIG. 27 is a cross-sectional view of a cutting element having a recessed surface in a cutting face of a superabrasive table interacting with a formation during drilling operations at a relatively low depth-of-cut, according to an embodiment of the present disclosure.

[0039] FIG. 28 is a cross-sectional view of a cutting element having a recessed surface in a cutting face of a superabrasive table interacting with a formation during drilling operations at a relatively high depth-of-cut, according to an embodiment of the present disclosure.

[0040] FIG. 29 is a cross-sectional view of a cutting element without a recessed surface in a cutting face of a superabrasive table interacting with a formation during drilling operations and showing chip formation.

[0041] FIG. 30 is a cross-sectional view of a cutting element with a recessed surface in a cutting face of a superabrasive table interacting with a formation during drilling operations and showing fractured formation in granular form, according to an embodiment of the present disclosure.

[0042] FIG. 31 is a partial cross-sectional side view of an earth-boring drill bit illustrating selective placement of cutting elements, according to an embodiment of the present disclosure.

[0043] FIG. 32 is a bottom view of an earth-boring drill bit illustrating selective
5 placement of cutting elements, according to an embodiment of the present disclosure.

DETAILED DESCRIPTION

[0044] The illustrations presented herein are not actual views of any particular earth-boring tool, drill bit, or component of such a tool or bit, but are merely idealized
10 representations which are employed to describe embodiments of the present disclosure.

[0045] As used herein, the term earth-boring tool means and includes any tool used to remove formation material and form a bore (*e.g.*, a wellbore) through the formation by way of the removal of the formation material. Earth-boring tools include, for example, rotary drill bits (*e.g.*, fixed-cutter or “drag” bits and roller cone or “rock” bits), hybrid bits including both fixed
15 cutters and roller elements, coring bits, percussion bits, bi-center bits, reamers (including expandable reamers and fixed-wing reamers), and other so-called “hole-opening” tools.

[0046] As used herein, the term “cutting element” means and includes any element of an earth-boring tool that is used to cut or otherwise disintegrate formation material when the earth-boring tool is used to form or enlarge a bore in the formation.

[0047] FIG. 1 illustrates an embodiment of an earth-boring tool of the present
20 disclosure. The earth-boring tool of FIG. 1 is a fixed-cutter rotary drill bit 10 having a bit body 11 that includes a plurality of blades 12 that project outwardly from the bit body 11 and are separated from one another by fluid courses 13. The portions of the fluid courses 13 that extend along the radial sides (the “gage” areas of the drill bit 10) are often referred to in the art as “junk
25 slots.” The bit body 11 further includes a generally cylindrical internal fluid plenum, and fluid passageways that extend through the bit body 11 to the exterior surface of the bit body 11. Nozzles 18 may be secured within the fluid passageways proximate the exterior surface of the bit body 11 for controlling the hydraulics of the drill bit 10 during drilling. A plurality of cutting
30 elements 20 is mounted to each of the blades 12.

[0048] During a drilling operation, the drill bit 10 may be coupled to a drill string (not shown). As the drill bit 10 is rotated within the wellbore, drilling fluid may be pumped down the drill string, through the internal fluid plenum and fluid passageways within the bit body 11

of the drill bit 10, and out from the drill bit 10 through the nozzles 18. Formation cuttings generated by the cutting elements 20 of the drill bit 10 may be carried with the drilling fluid through the fluid courses 13, around the drill bit 10, and back up the wellbore through the annular space within the wellbore outside the drill string.

5 [0049] FIG. 2 is a side view of a partially cut-away of cutting element 20 of the drill bit 10 of FIG. 1. The cutting element 20 includes a cutting element substrate 22 having a superabrasive table, such as a diamond table 24 thereon. The diamond table 24 may comprise a polycrystalline diamond (PCD) material, having a cutting face 26 defined thereon.

10 Superabrasive materials may also be characterized as “superhard” materials and include natural and synthetic diamond, cubic boron nitride and diamond-like carbon materials. Additionally, an interface 28 may be defined between the cutting element substrate 22 and diamond table 24. Optionally, the diamond table 24 may have a chamfered edge 30. The chamfered edge 30 of the diamond table 24 shown in FIG. 2 has a single chamfer surface 32, although the chamfered edge 30 also may have additional chamfer surfaces, and such additional chamfer surfaces may be
15 oriented at chamfer angles that differ from the chamfer angle of the chamfer surface 32, as known in the art. The cutting element substrate 22 may have a generally cylindrical shape, as shown in FIG. 2. One or more arcuate, or “radiused” edges or edge portions may be employed in lieu of, or in addition to, one or more chamfered surfaces at a peripheral edge of the diamond table, as known to those of ordinary skill in the art.

20 [0050] The diamond table 24 may be formed on the cutting element substrate 22, or the diamond table 24 and the cutting element substrate 22 may be separately formed and subsequently attached together. The cutting element substrate 22 may be formed from a material that is relatively hard and resistant to wear. For example, the cutting element substrate 22 may be formed from and include a ceramic-metal composite material (which is
25 often referred to as a “cermet” material). The cutting element substrate 22 may include a cemented carbide material, such as a cemented tungsten carbide material, in which tungsten carbide particles are cemented together in a metallic binder material. The metallic binder material may include, for example, cobalt, nickel, iron, or alloys and mixtures thereof. In some instances, cutting element substrate 22 may comprise two pieces, the piece immediately
30 supporting diamond table 24 and on which may be formed and bonded to another, longer piece of like diameter. In any case, the cutting elements 20 may be secured in pockets on blades 12 as depicted in FIG. 1, such as by brazing.

[0051] A recessed surface 34 may be defined in the cutting face 26 of the cutting element 20. For example, a generally annular, recessed surface 34 may be defined in the cutting face 26 of the cutting element 20, as shown in FIGS. 2 and 3. The recessed surface 34 may be positioned proximate to an edge of the cutting element 20, such as proximate to the chamfer surface 32. In some embodiments, the recessed surface 34 may be substantially planar and may be substantially parallel to a substantially planar surface 36 of the cutting face 26. As a non-limiting example, the recessed surface 34 may have a depth D of between about 0.0254 mm and about 2.54 mm relative to substantially planar surfaces 36 of the cutting face 26. The radially outer edge of the recessed surface 34 may be positioned a distance X of between about 13 mm and about 19 mm from the chamfer surface 32, and the chamfer edge 30 may have a width W of between about 0.254 mm and about 0.483 mm. In one embodiment, the radially outer edge of the recessed surface 34 may be positioned a distance X of about 13 mm from the chamfer surface 32, and the chamfer edge 30 may have a width W of about 0.254 mm. In another embodiment, the radially outer edge of the recessed surface 34 may be positioned a distance X of about 16 mm from the chamfer surface 32, and the chamfer edge 30 may have a width W of about 0.406 mm. In a further embodiment, the radially outer edge of the recessed surface 34 may be positioned a distance X of about 19 mm from the chamfer surface 32, and the chamfer edge 30 may have a width W of about 0.483 mm. Additionally, at least one angled surface 37 (e.g., angled relative to the substantially planar cutting surface 36 of the cutting face 26) may extend between the substantially planar surface 36 of the cutting face 26 and the recessed surface 34.

[0052] In additional embodiments, the recessed surface 34 may be defined by shapes other than an annulus. For example, the recessed surface 34 may have a generally circular shape, such as shown in FIGS. 4 and 5. For another example, the recessed surface 34 may be generally shaped as a regular n-sided polygon, where n may have any value from 3 to infinity, whereby n equal to infinity is equivalent to the aforementioned circular embodiment. In one embodiment, as shown in FIGS. 6 and 7, the recessed surface 34 may be generally shaped as a square. In another embodiment, as shown in FIGS. 8 and 9, the recessed surface 34 may be generally shaped as a pentagon. In some embodiments, an island or protrusion 39 may be positioned at or near a center of the recessed surface 34, such as shown in FIGS. 2, 3, 7 and 9. The protrusion 39 may have an average feature height defined by a plane that is coplanar with the substantially planar surface 36 of the cutting face 26, as shown in FIG. 3. However, in

alternative embodiments, the protrusion 39 may have an average feature height above or below the substantially planar surface 36 of the cutting face 26. In additional embodiments, the recessed surface 34 may be generally shaped as a Reuleaux polygon (i.e., a curvilinear polygon built up of circular arcs), such as a Reuleaux triangle as shown in FIG. 10.

5 [0053] In some embodiments, a cutting element 20 may include a plurality of recessed surfaces 34 spaced a distance X from a chamfer surface 32, such as shown in FIGS. 11-18. In some embodiments, the plurality of recessed surfaces may comprise a plurality of generally circular shaped recessed surfaces, such as shown in FIGS. 11-14. For example, a region of the cutting face of the cutting element 20 may have the appearance of a dimpled surface of a golf
10 ball. In further embodiments, the plurality of recessed surfaces may comprise a plurality of generally polygonal shaped recessed surfaces, such as hexagon shapes as shown in FIGS. 15-17, or square shapes as shown in FIG. 18. In some embodiments, the plurality of recessed surfaces 34 may be distributed in a generally annular region of the cutting face of the cutting element 20, such as shown in FIGS. 11, 12, 15 and 18. In further embodiments, the plurality of recessed
15 surfaces 34 may be distributed in a generally circular region of the cutting face of the cutting element 20, such as shown in FIGS. 13 and 16. In yet further embodiments, the plurality of recessed surfaces 34 may be distributed only in a region of the cutting face of the cutting element 20 that is near to an intended cutting edge of the cutting element, such as shown in FIGS. 14 and 17.

20 [0054] In some embodiments, as shown in FIGS. 19 through 22, a cutting element 20 may include a plurality of nested non-planar recessed surfaces 34, wherein each of the non-planar recessed surfaces is configured to engage the formation at a specific depth-of-cut. FIGS. 19 and 20 illustrate an embodiment of a cutting element 20 having a plurality of annular, concentric recessed surfaces 34 defined in the cutting face 26 of the cutting element 20. The
25 recessed surfaces 34 are symmetrical about the longitudinal axis 54 of the cutting element 20. FIG. 19 illustrates a cross-sectional side view of a cutting element 20 according to such an embodiment. The cutting element 20 includes a cutting element substrate 22 having a superabrasive table thereon, such as diamond table 24, as previously described. FIG. 19 shows a generally planar interface 28 defined between the cutting element substrate 22 and the diamond
30 table 24, although any interface geometry is within the scope of the present disclosure. Optionally, the diamond table 24 may have a chamfered edge 30 and a chamfer surface 32, as previously described herein.

[0055] The diamond table 24 may define three non-planar recessed surfaces 34a, 34b, 34c formed in the cutting face 26. Each of the recessed surfaces 34a, 34b, 34c depicted in FIG. 19 is symmetrical about the longitudinal axis 54 of the cutting element 20. Each of the recessed surfaces 34a, 34b, 34c may have an arcuately-shaped cross-section or "contour," and each contour may be of a different radius. For example, a first, radially outermost recessed surface 34 may have first cross-sectional radius R_1 ; a second recessed surface 34' may have a second cross-sectional radius R_2 ; and a third recessed surface 34'' may have a third cross-sectional radius R_3 . As shown in FIG. 19, the third radius R_3 is greater than both the first radius R_1 and second radius R_2 , and the second radius R_2 is greater than the first radius R_1 . Moreover, the radially outer edge of the first recessed surface 34a may be positioned a first distance X_1 from the chamfer surface 32; the radially outer edge of the second recessed surface 34b may be positioned a second distance X_2 from the chamfer surface 32; and the radially outer edge of the third recessed surface 34c may be positioned a third distance X_3 from the chamfer surface. As shown in FIG. 19, the third distance X_3 is greater than both the first distance X_1 and the second distance X_2 , and the second distance X_2 is greater than the first distance X_1 . In this manner, the recessed surfaces 34a, 34b, 34c may be respectively located to engage formation material at different respective depths-of-cut, or alternatively, after the diamond table 24 has worn to different extents.

[0056] As shown 20, the recessed surfaces 34a, 34b, 34c may be annular surfaces concentrically aligned, and each may be symmetrical about the longitudinal axis of the cutting element. It is to be appreciated that the three recessed surfaces 34a, 34b, 34c depicted in FIGS. 19 and 20 are merely one alternative of any number of concentric, annular recessed surfaces which may be formed in the cutting face 26 of a cutting element 20 according to the present disclosure. In additional embodiments, more than three or less than three recessed surfaces 34 may be formed in the cutting face 26 of the cutting element 20. FIG. 21 illustrates a cutting element 20 having more than three recessed surfaces 34 formed in the cutting face 26 of the cutting element 20. By adjusting the parameters of the recessed surfaces 34a-c of the cutting element 20 of FIGS. 19 through 21, a plurality of specific, tailored performance characteristics can be imparted to the cutting element 20. For example, the radius of each recessed surface may be set according to a predetermined degree of cutting aggressivity and efficiency desired for that radial region of the cutting element 20. For example, recessed surfaces with smaller respective radiuses, such as recessed surface 34a with radius R_1 of FIG. 19, may be utilized to manage residual stresses in the diamond table 24 and increase durability of the cutting element 20.

Additionally, recessed surfaces with larger respective radiuses, such as recessed surface 34b with radius R_2 of FIG. 19, may be utilized to increase the aggressivity and efficiency of the cutting element 20. Moreover, the utilization of multiple nested recessed surfaces 34a-c in the cutting face 26 reduces stress concentrations in the cutting face 26 and diamond table 24, which may increase the durability and longevity of the cutting element 20. The benefits regarding such reduction in stress concentration is explained by author Walter D. Pilkey in PETERSON'S STRESS CONCENTRATION FACTORS (2d ed., Wiley Interscience 1997), in Section 2.6.6, on page 71. Thus, by utilizing the concentric, nested configuration of the recessed surfaces 34a-c in the cutting element 20 depicted in FIGS. 19 through 21, cutting performance characteristics, such as aggressivity and efficiency, may be tailored to occur at a predetermined depth-of-cut, while balancing durability over a greater portion of the cutting face 26. For example, if a high cutting aggressivity and efficiency are desired at a shallow depth-of-cut, an annular recessed surface with a large respective radius, such as recessed surface 34b with radius R_2 of FIG. 19, may be located at a relatively short radial distance, such as X_1 , from the chamfer surface 20 of the diamond table 24. Additionally, if residual stress management is also desired on the diamond table 24 at a greater depth-of-cut, a recessed surface with a smaller respective radius, such as recessed surface 34a with radius R_1 of FIG. 19, may be nested radially inward, such as at radial distance X_2 or X_3 of FIG. 19, of the more aggressive recessed surface.

[0057] While FIG. 19 illustrates the recessed surfaces 34a-c as being semicircular arcuate shapes, i.e., having one cross-sectional radius, in alternative embodiments, semielliptical cross-sectional shapes may be utilized. Furthermore, in other embodiments, non-planar recessed surfaces with cross-sectional geometries other than arcuate shapes may be formed in the cutting face 26 of the cutting element 20. FIG. 22 depicts three annular, concentric, chevron-shaped recessed surfaces 34d, 34e, 34f formed in the cutting face 26 of the cutting element 20. The cutting element 20 of FIG. 22 may otherwise be configured similarly to the cutting element 20 of FIGS. 19 and 20. Each of the recessed surfaces 34d, 34e, 34f depicted in FIG. 22 is symmetrical about the longitudinal axis 54 of the cutting element 20. Thus, it is to be recognized that the chevron-shaped recessed surfaces are non-planer in three-dimensional space. Each chevron-shaped recessed surface 34d, 34e, 34f may have a symmetrical chevron shape, as depicted in FIG. 22. In alternative embodiments, non-symmetrical chevron shapes may be utilized. In yet other embodiments, a cutting face 26 may include one or more symmetrical chevron-shaped recessed surfaces in combination with one or more non-symmetrical chevron-

shaped recessed surfaces. Referring again to FIG. 22, a first, radially outermost, symmetrical, chevron-shaped recessed surface 34d may extend to a first depth within the diamond table 24 at a first angle θ_1 with respect to the planar, longitudinally outer surface of the cutting face 26. A second, symmetrical, chevron-shaped recessed surface 34e may extend to a second depth within the diamond table 24 at a second angle θ_2 with respect to the planar, longitudinally outer surface of the cutting face 26. A third recessed surface 34f may extend to a third depth within the diamond table 24 at a third angle θ_3 with respect to the planar, longitudinally outer surface of the cutting face 26. The angles $\theta_1, \theta_2, \theta_3$ may be equivalent or unique with respect to one another. For example, FIG. 22 depicts angles θ_2 and θ_3 as being equivalent, and both being greater than θ_1 . Moreover, the depth to which the second and third chevron-shaped recessed surfaces 34e, 34f extends from the cutting face 26 into the diamond table 24 is depicted as being equivalent, with both being less than the depth to which the first chevron-shaped recessed surface 34d extends from the cutting face 26 into the diamond table 24. With continued reference to FIG. 22, the radially outer edge of the first recessed surface 34d may be positioned a distance X_1 from the chamfer surface 32; the radially outer edge of the second recessed surface 34e may be positioned a distance X_2 from the chamfer surface 32; and the radially outer edge of the third recessed surface 34f may be positioned a distance X_3 from the chamfer surface. As shown in FIG. 22, the third distance X_3 is greater than both the first distance X_1 and the second distance X_2 , and the second distance X_2 is greater than the first distance X_1 . In this manner, the recessed surfaces 34d, 34e, 34f may be respectively located to engage formation material at a specific depth-of-cut, or alternatively, after the diamond table 24 has worn to a specific extent.

[0058] As described above with reference to the arcuate-shaped recessed surfaces 34a-c of FIGS. 19 through 21, more than three or less than three chevron-shaped recessed surfaces 34d-f may be formed in the cutting face 26 of the cutting element 20. Furthermore, as described above, by adjusting the parameters of the chevron-shaped recessed surfaces 34a-c of the cutting element 20 of FIG. 22, including angles θ_{1-3} , radial distances X_{1-3} from the chamfer surface 32, and depth into the diamond table 24 from the cutting face 26, a plurality of specific, tailored performance characteristics, such as durability, aggressivity, and efficiency, can be imparted to the cutting element 20 at different radial locations, i.e., depth-of-cut locations, on the cutting face 26. Additionally, any combination of planar and/or non-planar cross-sectionally shaped recess surfaces 34a-f may be utilized in a single cutting element 20. For example, a combination of arcuate-shaped recessed surfaces 34a-c, chevron-shaped recessed surfaces 34d-f, and

alternatively-shaped recessed surfaces may be nested in a concentric pattern on the cutting face 26. Furthermore, in yet additional embodiments, planar and/or non-planar recessed surfaces 34, such as the arcuate and chevron cross-sectional recessed surfaces 34a-f shown in FIGS. 19 and 22, may be utilized on a cutting face 26 in a non-concentric configuration. Moreover, a nested configuration of planar and/or non-planar recessed surfaces 34a-f may be utilized in a non-symmetrical pattern with respect to the longitudinal axis L of the cutting element 20. It is to be appreciated that a plurality of recessed surfaces 34 of any combination of cross-sectional shapes, patterns, dimensions, and orientations, as disclosed above, may be utilized in a single cutting face 26 to impart a desired performance characteristic to a cutting element 20.

10 **[0059]** The one or more recessed surfaces 34 may be formed in the diamond table 24 after the diamond table 24 has been formed, such as by using electrical discharge machining (EDM), whereby a desired shape is achieved by using electrical discharges from an electrode (not shown). In some embodiments, the diamond table 24 may be moved relative an electrode having a shape of a desired cross-section of the recessed surface 34 (and/or the electrode may be moved along a desired path relative to the diamond table 24) to form the recessed surface 34 (FIG. 3). For example, an electrode having a polygonal shape may be lowered into the cutting face 26 of the diamond table 24, and then the diamond table 24 may be rotated to form a recessed surface 34 comprising a polygonal groove following an annular path. In additional embodiments, one or more electrode dies having a negative shape of the desired recessed surface or surfaces 34 (i.e., one or more protrusions), may be sunk into the cutting face 26 of the diamond table 24 to form one or more recessed surfaces 34.

25 **[0060]** In some embodiments, the one or more recessed surfaces 34 in the diamond table 24 may include one or more sacrificial structures 42 positioned therein. For example, one or more sacrificial structures 42 may substantially fill the area over the one or more recessed surfaces 34 in the diamond table 24, such that a surface 44 of each sacrificial structure 42 may be substantially aligned and coplanar with the adjacent, substantially planar surfaces 36 of the cutting face 26 of the diamond table 24, as shown in FIG. 23. In another example, each sacrificial structure 42 may be a relatively thin material layer positioned over the recessed surface 34, as shown in FIG. 24. In some embodiments, each sacrificial structure 42 may be comprised of a material that is softer than the diamond table 24, or that is otherwise more susceptible to wear than the diamond table 24, such as one or more of a ceramic, a cermet and a refractory metal. For example, the material of each sacrificial structure 42 may be one or more

of tungsten carbide, aluminum oxide, tungsten, niobium, tantalum, hafnium, molybdenum, and carbides formed therefrom.

[0061] In such embodiments, the recessed surface 34 may be formed into the diamond table 24 during the formation of the diamond table 24. For example, each sacrificial structure 42
5 may be positioned within a mold (not shown) and powdered precursor material comprising diamond particles may be positioned over (e.g., around) each sacrificial structure 42. Then the powdered precursor material may be compacted and sintered in the presence of a catalyst mixed with the diamond particles or swept from an adjacent substrate as known in the art to form the diamond table 24, with each sacrificial structure 42 forming a corresponding recessed surface 34
10 in the diamond table 24. Each sacrificial structure 42, or a portion thereof, may then be removed, such as by sandblasting, machining, acid leaching or another process, or each sacrificial structure 42, or a portion thereof, may remain positioned in each corresponding recessed surface 34 to be removed by the formation during drilling operations. Additionally, for embodiments wherein each sacrificial structure 42, or a portion thereof, may then be removed,
15 such as by sandblasting, machining, acid leaching or another process, the diamond table 24 may be machined, such as by an EDM process, to a final geometry.

[0062] In further embodiments, a powder perform, such as a diamond comprising powder contained in a cylindrical niobium cup, may be positioned adjacent a shaped mold, such as a mold having a shaped protrusion, during at least a portion of the sintering process. For
20 example, the powder perform may be positioned adjacent the shaped mold (not shown) during a high-pressure/high-temperature (HPHT) process and a shape imparted by the shaped mold may be retained throughout a sintering cycle to form a recessed surface 34 in the diamond table 24. In further embodiments, the shape imparted by the mold may be near a desired net shape of the one or more recessed surfaces 34, and the final shape of the one or more recessed surfaces 34
25 may be machined, such as by an EDM process, to a final geometry.

[0063] Optionally, the catalyst material may be removed from the hard polycrystalline material of the diamond table 24 after the HPHT process, as known in the art. For example, a leaching process may be used to remove catalyst material from interstitial spaces between the inter-bonded grains of the hard polycrystalline material of the diamond table 24. By way of
30 example and not limitation, the hard polycrystalline material may be leached using a leaching agent and process such as those described more fully in, for example, U.S. Patent No. 5,127,923 to Bunting et al., (issued July 7, 1992), and U.S. Patent No. 4,224,380 to Bovenkerk et al.,

(issued September 23, 1980), the disclosure of each of which patent is incorporated herein in its entirety by this reference. Specifically, *aqua regia* (a mixture of concentrated nitric acid (HNO₃) and concentrated hydrochloric acid (HCl)) may be used to at least substantially remove catalyst material from the interstitial spaces between the inter-bonded grains in the hard polycrystalline material of the diamond table 24. It is also known to use boiling hydrochloric acid (HCl) and boiling hydrofluoric acid (HF) as leaching agents. One particularly suitable leaching agent is hydrochloric acid (HCl) at a temperature of above 110°C, which may be provided in contact with the hard polycrystalline material of the diamond table 24 for a period of about two hours to about 60 hours, depending upon the size of the body comprising the hard polycrystalline material. After leaching the hard polycrystalline material, the interstitial spaces between the inter-bonded grains within the hard polycrystalline material may be at least substantially free of catalyst material used to catalyze formation of inter-granular bonds between the grains in the hard polycrystalline material. In some embodiments, leaching may be selectively applied to specific regions of the diamond table 24, and not to other regions. For example, in some embodiments, a mask may be applied to a region of the diamond table 24, such as one or more recessed surfaces 34 or a region of a recessed surface 34 in the diamond table 24, and only the unmasked regions may be leached.

[0064] Additionally, an outer surface of the diamond table 24 may be physically modified, such as by polishing to a smooth or mirrored finish. For example, an outer surface of the diamond table 24 may have a reduced surface roughness, such as described in U.S. Patent No. 6,145,608, which issued on November 14, 2000 to Lund et al., and is assigned to the assignee of the present application; U.S. Patent No. 5,653,300, which issued August 5, 1997 to Lund et al., and is assigned to the assignee of the present application; and U.S. Patent No. 5,447,208, which issued September 5, 1995 to Lund et al., and is assigned to the assignee of the present application, the disclosure of each of which is incorporated herein in its entirety by this reference.

[0065] In conventional PDC cutting elements, a cutting face or leading face of PDC might be lapped to a surface finish of 20 μ in. (about 0.508 μm) to 40 μ in. (about 1.02 μm) root mean square RMS (all surface finishes referenced herein being RMS), which is relatively smooth to the touch and visually planar (if the cutting face is itself flat), but which includes a number of surface anomalies and exhibits a degree of roughness which is readily visible to one even under very low power magnification, such as a 10x jeweler's loupe. However, an exterior

surface of the diamond table 24 may be treated to have a greatly reduced surface roughness. As a non-limiting example, an exterior surface of the diamond table 24 may be polished a surface roughness of about 0.5 μ in. (about 0.0127 μ m) RMS.

[0066] In some embodiments, the surface roughness of a surface of the diamond table 24 may be reduced by lapping of the cutting face 26 on conventional cast iron laps known in the art by using progressively smaller diamond grit suspended in a glycol, glycerine or other suitable carrier liquid. The lapping may be conducted as a three-step process commencing with a 70 micron grit, progressing to a 40 micron grit and then to a grit of about 1 to 3 microns in size. In contrast, standard lapping techniques for a PDC cutting element, which may follow an initial electrodischarge grinding of the cutting face, finish lapping in one step with 70 micron grit. By way of comparison of grit size, 70 micron grit is of the consistency of fine sand or crystalline material, while 1 to 3 micron grit is similar in consistency to powdered sugar.

[0067] In additional embodiments, the surface roughness of a surface of the diamond table 24 may be reduced by placing the surface in contact with a dry, rotating diamond wheel. For example, the Winter RB778 resin bonded diamond wheel, offered by Ernst Winter & Sons, Inc. of Travelers Rest, S.C., may be utilized. It may be important that the wheel be cooled as the diamond wheel is of resin bonded construction. Elevated temperatures may result in the destruction of the wheel. The nature of the polishing process may require that the abrasive surface be kept dry. However, the wheel may be moistened with water at the start of the polishing process to reduce drag and facilitate proper orientation of the diamond table 24 against the wheel. In addition, a temperature range wherein polishing may be effected may be between about 140°F (about 60°C) and about 220°F (about 104°C). While specific polishers employed may rotate at about 3500 RPM, it is believed that a range between about 3000 RPM and about 5000 RPM would likely be adequate. About 2 lb. force (about 0.9 Kg) to about 8 lb. force (about 3.6 Kg) may be applied to the diamond table 24 against the wheel. As noted, the finish of an exterior surface of the diamond table 24 may be smoothed to about 0.5 μ in. (about 0.0127 μ m) RMS or less surface finish roughness approaching a true "mirror" finish. It may take about fifty minutes to about an hour of polishing with the aforementioned diamond wheel to achieve this finish on a surface of a one-half inch (about 1.27 cm) diameter diamond table 24, and about one and one-half to about two hours for a nominal three-quarter inch (about 1.905 cm) diameter diamond table 24. This same method described for polishing a face of the diamond table 24 may also be applied to polish the chamfer 32, as well as the side of the diamond table

24. To polish such surfaces, the diamond table 24, held by the substrate 22, is disposed at the desired angle to the rotating wheel. The cutting element 20 may then be rotated about an axis of symmetry to smooth and polish the chamfer 32 or other side areas of the diamond table 24.

Thus, one could smooth and polish a curved, ridged, waved or other cutting face of a diamond
5 table 24 to remove and reduce both large and small asperities, resulting in a mirror finish cutting face, which nonetheless is not flat in the absolute sense.

[0068] The cutting element cutting surfaces (cutting face, chamfer, side, etc.) may be polished by other methods, such as ion beams or chemicals, although the inherently inert chemical nature of diamond may make the latter approach somewhat difficult for diamond. The
10 cutting element surfaces may also be polished by the use of lasers, as described in United States Patent Publication No. 2009/0114628, to DiGiovanni, which was published May 7, 2009, the entire disclosure of which is incorporated herein in its entirety by this reference.

[0069] While an industry-standard PDC or other superhard cutting element may have a lapped surface finish on the cutting face with irregularities or roughness (measured vertically
15 from the surface) on the order of 20 μ in. (about 0.508 μ m) to 40 μ in. (about 1.02 μ m) RMS, as a result of the above-described polishing, some embodiments may have a diamond table 24 surface roughness between about 0.3 μ in. RMS and about 0.5 μ in. (about 0.0127 μ m) RMS. Additional embodiments may have a diamond table 24 surface roughness between about 0.4 μ in. (about 0.0102 μ m) RMS and about 0.6 μ in. (about 0.0152 μ m) RMS. In yet additional
20 embodiments, the diamond table 24 may have a surface roughness less than about 10 μ in. (about 0.254 μ m) RMS. In further embodiments, the diamond table 24 may have a surface roughness less than about 2 μ in. (about 0.0508 μ m) RMS. In yet further embodiments, the diamond table 24 may have a surface roughness less than about 0.5 μ in. (about 0.0127 μ m) RMS, approaching a true "mirror" finish. In yet further additional embodiments, the diamond
25 table 24 may have a surface roughness less than about 0.1 μ in. (about 0.00254 μ m). The foregoing surface roughness measurements of the diamond table 24 may be measured using a calibrated HOMMEL® America Model T-4000 diamond stylus profilometer contacting the surface of the diamond table 24.

[0070] In view of the foregoing, selected surfaces of the diamond table 24 may be
30 polished or otherwise smoothed to have a reduced surface roughness. In some embodiments, the substantially planar surfaces 36 of the cutting face 26 may have a reduced surface roughness. In further embodiments, the recessed surface(s) 34 may have a reduced surface roughness. In yet

further embodiments, the entire cutting face 26 of the diamond table 24 may have a reduced surface roughness. In additional embodiments, the chamfer 32 and/or other side surfaces of the diamond table 24 may have a reduced surface roughness. In yet additional embodiments, all of the exposed surfaces of the diamond table 24 may have a reduced surface roughness.

5 [0071] Referring now to FIG. 28, drilling forces caused by interaction between a formation 56 and the cutting element 20 may be exacerbated by stress concentrations within the diamond table 24 above that of an otherwise similar PDC cutter without a recessed surface feature 34. In view of this, a shape of the interface 28 between the diamond table 24 and the substrate 22 of the cutting element 20 may be configured to effectively distribute stresses caused
10 by cutting forces, to improve the structural integrity of the cutting element 20. For example, a shaped region 48 corresponding to a shape of the one or more recessed surfaces 34 in the cutting face 26 of diamond table 24 may define a region of the interface 28, such as shown in FIGS. 25 and 26. In some embodiments, the shaped region 48 of the interface 28 may be defined by a recessed surface 50 in the substrate 22 and a protrusion 52 (FIGS. 25 and 26) of the diamond
15 table 24 at the interface 28. In view of this, the shaped region 48 of the interface 28 may provide a generally uniform thickness of the diamond table 24. In some embodiments, the shaped region 48 of the interface 28 corresponding to the one or more recessed surfaces 34 in the diamond table 24 may be positioned directly, longitudinally, below the one or more recessed surfaces 34 in the diamond table 24, as shown in FIG. 25. In further embodiments, at least a portion of the
20 shaped region 48 of the interface 28 corresponding to the one or more recessed surfaces 34 in the diamond table 24 may underlie the one or more recessed surfaces 34 at a position radially inward of the one or more recessed surfaces 34 relative to a longitudinal axis 54 (FIG. 2) of the cutting element 20. In additional embodiments, at least a portion of the shaped region 48 of the interface 28 corresponding to the one or more recessed surfaces 34 in the diamond table 24 may
25 underlie the one or more recessed surfaces 34 at a position radially outward of the one or more recessed surfaces 34 relative to a longitudinal axis 54 (FIG. 2) of the cutting element 20, as shown in FIG. 26. Such a configuration may account for a projected direction of travel of the cutting element 20 relative to a formation (as indicated by the dashed lines in FIG. 26), as this may correspond to a primary general direction of cutting forces applied to the cutting element 20
30 during drilling operations. In other words, the shaped region of the interface 28 may be sized, shaped and positioned to reduce stress concentrations, and/or to provide sufficient structural strength to withstand anticipated stress concentrations, that may result from drilling operations.

Furthermore, the diamond layering composition of the diamond table 24 may be tailored in the shaped region to compensate for residual stresses and provide a tailored material property of the diamond table 24, such as a tailored strength and toughness, in the shaped region.

[0072] In some embodiments, a depth-of-cut limiting feature on an earth-boring tool
5 may be positioned to inhibit interaction between an uncut earth formation and one or more recessed surfaces 34 in the cutting face 26 of the diamond table 24 during earth-boring operations. For example, the depth-of-cut limiting feature on an earth-boring tool may be one or more of an outer surface of a blade 12 of the drill bit 10 shown in FIG. 1 and a bearing block feature as described in United States Patent Application Serial No. 12/766,988, filed April 26,
10 2010, for "BEARING BLOCKS FOR DRILL BITS, DRILL BIT ASSEMBLIES INCLUDING BEARING BLOCKS AND RELATED METHODS," the disclosure of which is incorporated herein in its entirety by this reference. For example, the depth-of-cut limiting feature may be positioned to be aligned with a radially outer edge of a recessed surface 34 in the cutting face 26 of the diamond table 24. In view of this, uncut formation may be prevented from contact with
15 the recessed surface 34 during drilling operations, such that the planar surface 36 of the cutting face 26 and the chamfer surface 32, positioned radially outward (relative to a primary axis of the cutting element 20) of the recessed surface 34 may interact with the uncut formation 56.

[0073] In operation at relatively small depths of cut, the uncut formation 56 may interact only with the chamfer surface 32 of the cutting element, as shown in FIG. 27. At greater
20 depths of cut, the uncut formation 56 may interact with the planar surface 36 of the cutting face 26 of the cutting element, as shown in FIG. 28. In view of this, at relatively low depths of cut, wherein the uncut formation 56 interacts only with the chamfer surface 32 of the cutting element 20, the cutting element 20 may exhibit a relatively high effective backrack angle α_1 (FIG. 27). At relatively high depths of cut, wherein the uncut formation 56 interacts with the planar surface
25 36 of the cutting face 26 of the cutting element 20, the cutting element 20 may exhibit a relatively low effective backrack angle α_2 (FIG. 28).

[0074] In view of the foregoing, at least one recessed surface 34 in the cutting face 26 of a cutting element 20 may be positioned and configured to inhibit or reduce the impacting of
30 cuttings removed from a formation 56 from compacting together at the cutting face and forming cohesive structures (i.e., chips). As shown in FIG. 28, when a cutting element 60 with a substantially planar cutting face 62 is pushed through uncut formation 64, the uncut formation 64 fractures and may then be substantially immediately compacted into the cutting face 62 of the

cutting element 60, due to the forward movement of the cutting element 60 relative to the formation 64. In view of this, the pieces of fractured formation 64 that impact the cutting face 62 of the cutting element 60 may become compressed together, forming a cohesive structure 66 known generally in the art as a "chip." However, when a cutting element 20 having at least one recessed surface 34, as described herein, in the cutting face 26 positioned just radially inward of the cutting edge at a sufficient depth is pushed through uncut formation 70, as shown in FIG. 30, granular pieces 72 of fractured formation 70 may be inhibited or prevented from impacting the cutting element 20 after fracturing. As a result, the granular pieces 72 of fractured formation 70 may not compress together sufficiently to form cohesive structures of any substantial size and may be carried away by drilling fluid as granular pieces 72 in discrete particulate form.

[0075] In light of this, the work required to penetrate a formation with an earth-boring tool comprising cutting elements 20 with at least one recessed surface 34 as described herein may be relatively low, as work that would ordinarily be expended by cutting elements compressing fractured formation to form chips may not be required. Furthermore, problems such as balling associated with cuttings or chips sticking to a bit face may be prevented or inhibited by utilizing cutting elements 20 with at least one recessed surface 34 as described herein, as the fractured formation in granular or particulate form may be readily carried away from a bit face by drilling fluid.

[0076] Performance factors, such as efficiency, aggressivity, and durability, of an earth-boring tool comprising cutting elements 20 with at least one recessed surface 34 as described herein may be tailored and balanced by strategic placement of such cutting elements 20 on the tool. Cutting elements 20 configured with one or more recessed surfaces 34, as described herein, may exhibit more aggressive and efficient cutting performance relative to conventional PDC cutting elements, albeit at the expense of less durability compared to conventional PCS cutting elements. Thus, performance of the cutting elements 20 may be further tailored for specific subterranean formations, such as, by way of non-limiting examples, horizontal shales or shaly sands. When harder or more interbedded formations are to be encountered, the tool design might retain a larger selection of conventional PDC cutters in the high depth-of-cut regions of the tool, while using the cutting elements 20, as described herein, in the lower depth-of-cut regions. FIG. 31 is a simple partial cross-sectional view illustrating an embodiment of an earth-boring tool utilizing selective placement of the cutting elements 20 of the present disclosure. For illustrative purposes, the earth-boring tool of FIG. 31 is the fixed-cutter rotary drill bit 10 of

FIG. 1, configured as previously described, although it is to be recognized that the selective placement embodiments disclosed herein may be incorporated on other earth-boring tools, such as reamers, hole-openers, casing bits, core bits, or other earth-boring tools.

[0077] As shown in FIG. 31, the drill bit 10 includes a plurality of cutting elements mounted to each blade 12 of the drill bit 10. Moreover, as understood in the art, a profile of a drill bit 10, configured as shown in FIG. 31, may comprise a cone region 74, a nose region 76, a shoulder region 78, and a gage region 80. Cutting elements located in the cone and nose region 74, 76 of a blade 12 may be exposed to a greater depth-of-cut in formation material relative to cutting elements located in other regions of the blade 12, but may be subjected to a lesser work rate than in other regions of the blade 12. Conversely, cutting elements located in the shoulder region 78 of the blade 12 may be exposed to a higher work rate, but a lesser depth-of-cut, than cutting elements in other regions of the blade 12. It is to be appreciated that cutting elements 20 having one or more recessed surfaces 34, as described previously, may be selectively located at specific regions of the blade to optimize one or more desired performance characteristics. As shown in FIG. 31, cutting elements 20, as described herein, may be selectively located in the cone region 74 and nose region 76, and may be configured with one or more recessed surfaces 34 tailored for specific high depth-of cut performance characteristics. Additionally, cutting elements 20, as described herein, may be selectively located in the shoulder region 78 of the blade 12, and may be configured with one or more recessed surfaces 34 tailored for specific high work rate performance characteristics. The gage region 80 of the blade 12 may be fitted with conventional PDC cutting elements. In additional embodiments (not shown), cutting elements 20 having one or more recessed surfaces 34, as described herein, may be selectively located in only one of the cone region 74, nose region 76, shoulder region 78, or gage region 80, while conventional PDC cutting elements may be located in the remaining regions. In yet other embodiments, cutting elements 20 having one or more recessed surfaces 34, as described herein, may be selectively located in any combination of the cone region 74, nose region 76, shoulder region 78, or gage region 80, with conventional PDC cutting elements located in the remaining regions of the blade 12.

[0078] Additionally, referring to FIG. 32, cutting elements 20 having one or more recessed surfaces 34, as described herein, may be selectively located on one or more blades 12 of the drill bit 10. As shown in FIG. 32, a drill bit 10 may be configured with cutting elements 20, as described herein, on alternating blades 12a-c of the drill bit 10, while the remaining blades

12 may be fitted with conventional PDC cutting elements. Benefits of such placement may include, among others, an optimal balance of the aggressivity, stability and steerability of the drill bit 10. It is to be appreciated that in further embodiments, cutting elements, such as cutting elements 20 described herein, may be selectively placed on specific blades and on specific regions of each specific blade, as described previously, to further tailor performance characteristics of the drill bit.

[0079] Although the foregoing description contains many specifics, these are not to be construed as limiting the scope of the present disclosure, but merely as providing certain example embodiments. Similarly, other embodiments of the disclosure may be devised which are within the scope of the present disclosure. For example, features described herein with reference to one embodiment may also be combined with features of other embodiments described herein. The scope of the disclosure is, therefore, indicated and limited only by the appended claims and their legal equivalents, rather than by the foregoing description. All additions, deletions, and modifications to the disclosure, as disclosed herein, which fall within the meaning and scope of the claims, are encompassed by the present disclosure.

CLAIMS

What is claimed is:

- 5 1. A cutting element for an earth-boring tool, comprising:
a superabrasive table positioned on a substrate; and
at least one substantially planar recessed surface in a cutting face of the superabrasive table.
2. The cutting element of claim 1, wherein the at least one substantially planar
10 recessed surface is positioned substantially parallel with a substantially planar surface of a
cutting face of the cutting element.
3. The cutting element of claim 1, wherein the recessed surface is generally shaped
as one of a circle, a polygon, and a Reuleaux polygon.
- 15 4. The cutting element of claim 1, wherein the superabrasive table comprises a
surface having a surface roughness less than about 10 μ in. RMS.
5. The cutting element of claim 4, wherein the superabrasive table comprises a
20 surface having a surface roughness less than about 0.5 μ in. RMS.
6. An earth-boring tool, comprising:
at least one cutting element comprising:
a superabrasive table positioned on a substrate;
25 a recessed surface in a cutting face of the superabrasive table; and
a shaped feature in the substrate at an interface between the superabrasive table and the
substrate corresponding to the recessed surface in the cutting face of the
superabrasive table.

7. The cutting element of claim 6, wherein the shaped feature in the substrate at the interface between the superabrasive table and the substrate comprises a recessed surface in the substrate having a shape similar to the shape of the recessed surface in the cutting face of the superabrasive table.

5

8. The cutting element of claim 6, wherein the recessed surface is generally shaped as one of a circle, a polygon, and a Reuleaux polygon.

9. The cutting element of claim 6, wherein the superabrasive table comprises a surface having a surface roughness less than about 10 μ in. RMS.

10

10. The cutting element of claim 9, wherein the superabrasive table comprises a surface having a surface roughness less than about 2 μ in. RMS.

11. The cutting element of claim 10, wherein the superabrasive table comprises a surface having a surface roughness less than about 0.5 μ in. RMS.

15

12. An earth-boring tool, comprising:

at least one cutting element comprising:

20

a superabrasive table positioned on a substrate; and

at least one substantially planar recessed surface in a cutting face of the superabrasive table.

13. The earth-boring tool of claim 12, further comprising:

a depth-of-cut limiting feature positioned on the earth-boring tool to inhibit interaction between uncut earth formation and the recessed surface in the cutting face of the superabrasive table during earth-boring operations.

25

14. The earth-boring tool of claim 13, wherein the depth-of-cut limiting feature is aligned with a radially outer edge of the recessed surface in the cutting face.

30

15. An earth-boring tool, comprising:
at least one cutting element comprising:
a superabrasive table positioned on a substrate; and
a plurality of non-planar recessed surfaces in a cutting face of the superabrasive table.

5

16. The earth-boring tool of claim 15, wherein the non-planar recessed surfaces are substantially concentrically aligned.

17. The earth-boring tool of claim 15, wherein at least one of the plurality of non-planar recessed surfaces defines one of an arcuate and a chevron cross-sectional shape in the superabrasive table.

10

18. An earth-boring tool, comprising:
at least one blade; and
a plurality of cutting elements, each cutting element of the plurality of cutting elements comprising:
a superabrasive table positioned on a substrate;
at least one recessed surface in a cutting face of the superabrasive table, at least one cutting element of the plurality of cutting elements being affixed to one or more of a cone, nose, shoulder and gage region of the at least one blade.

15

20

19. The earth-boring tool of claim 18, wherein the at least one blade comprises two or more blades, at least a second cutting element of the plurality of cutting elements being affixed to one or more of a cone, nose, shoulder, and gage region of a second blade of the two or more blades.

25

20. A method of forming a cutting element as hereinabove described.

30

+

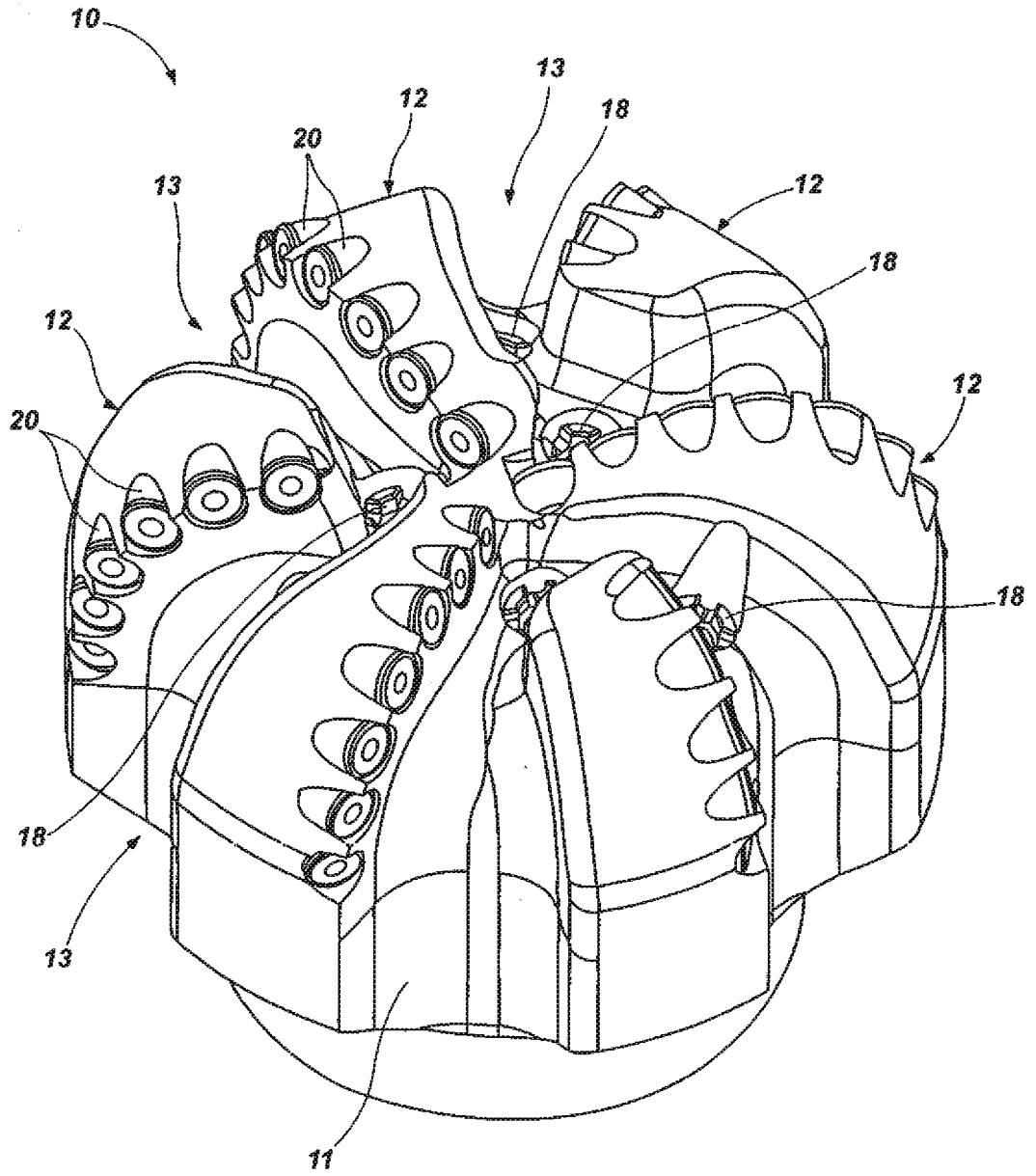

FIG. 1

+

+

2/12

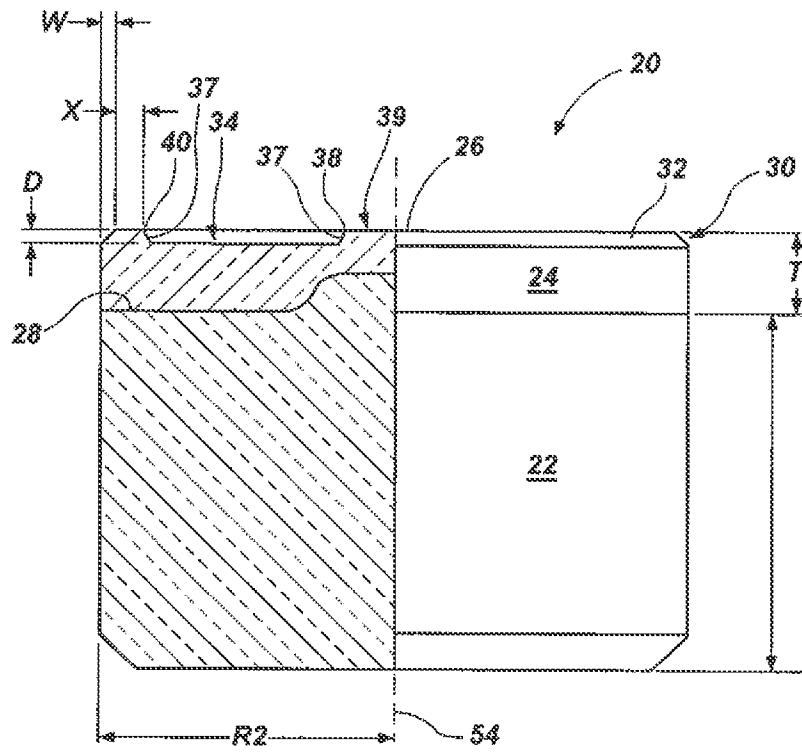

FIG. 2

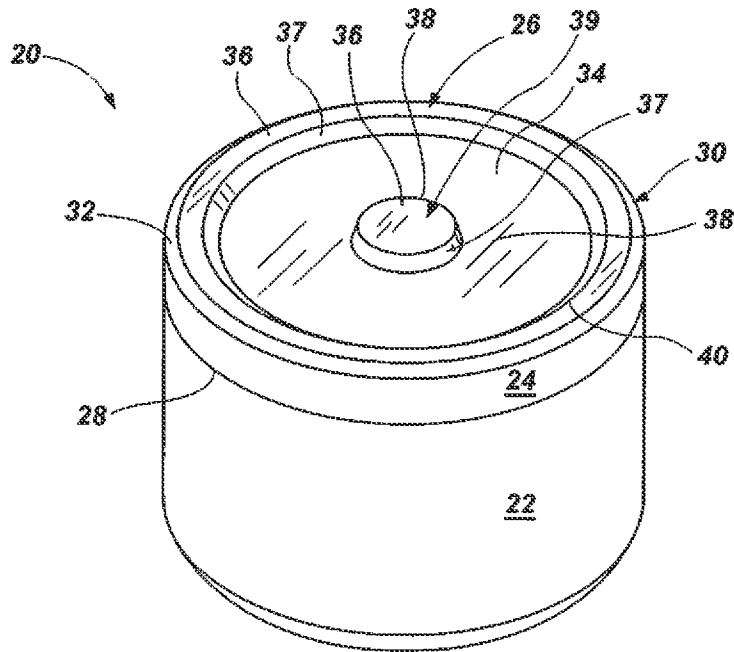

FIG. 3

+

+

3/12

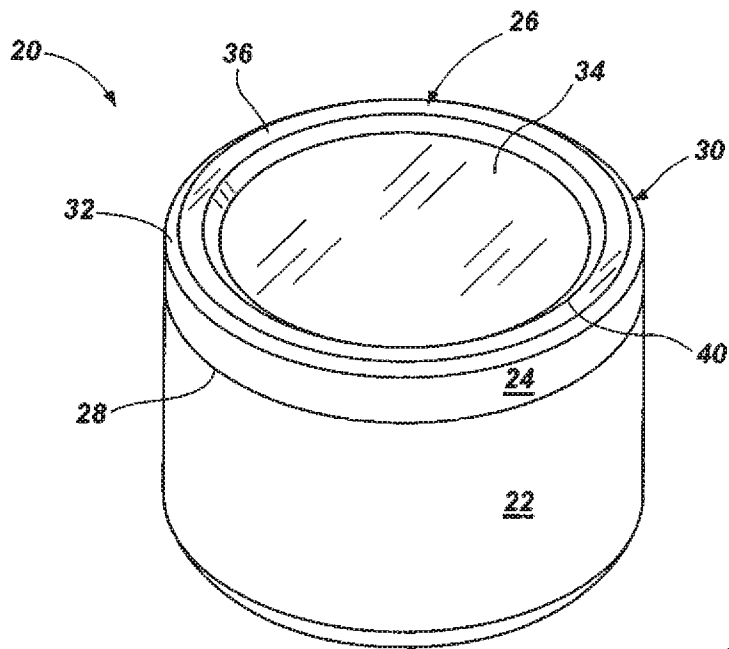

FIG. 4

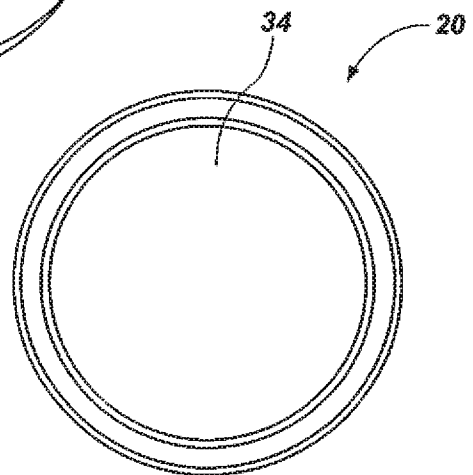

FIG. 5

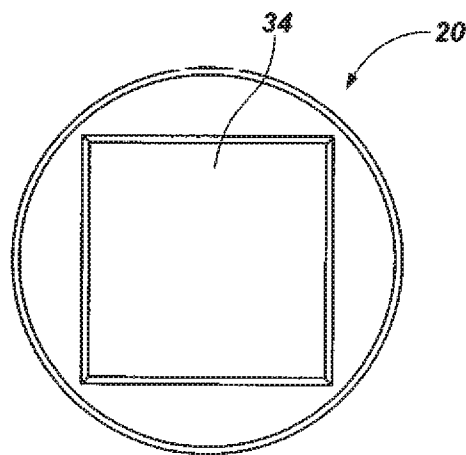

FIG. 6

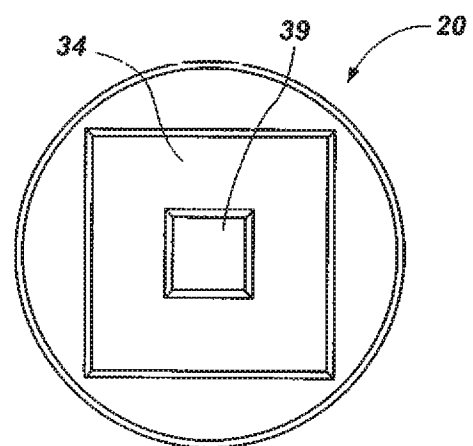

FIG. 7

+

+

4/12

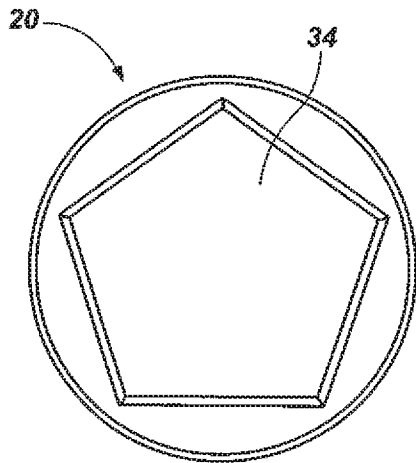

FIG. 8

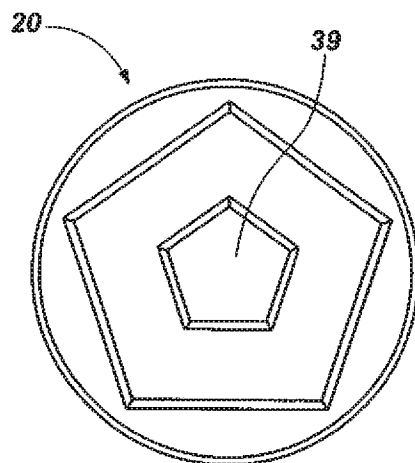

FIG. 9

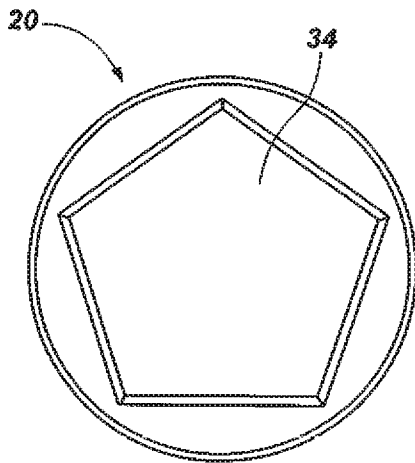

FIG. 10

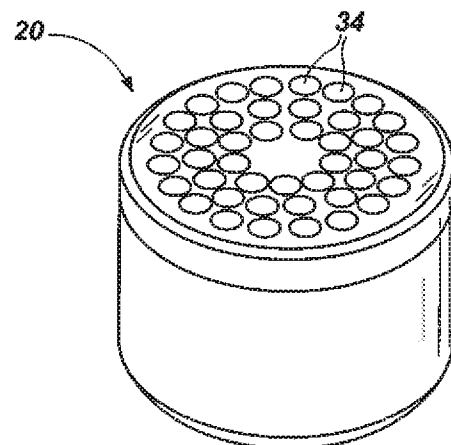

FIG. 11

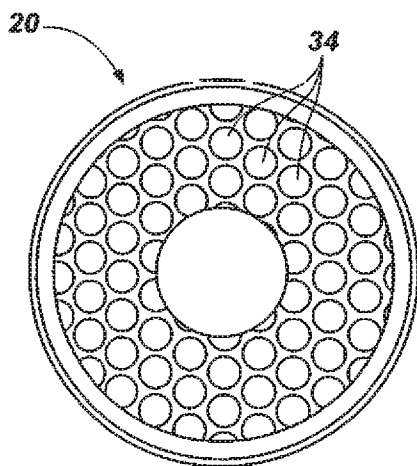

FIG. 12

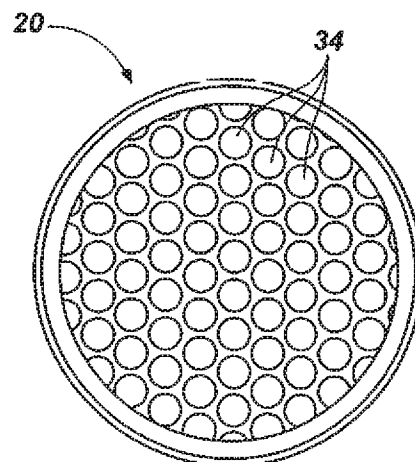

FIG. 13

+

+

5/12

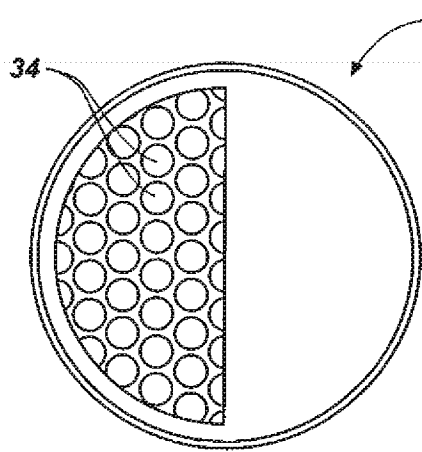

FIG. 14

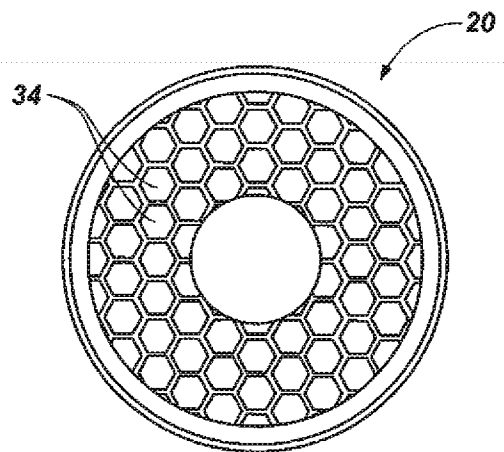

FIG. 15

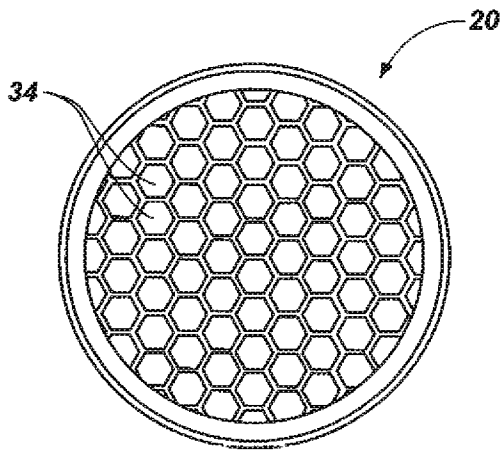

FIG. 16

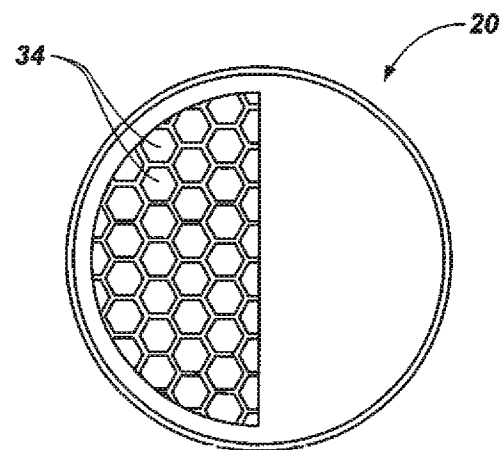

FIG. 17

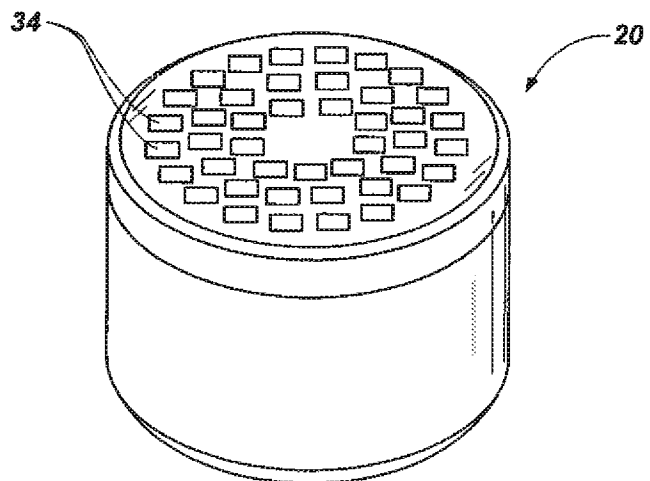

FIG. 18

+

+

6/12

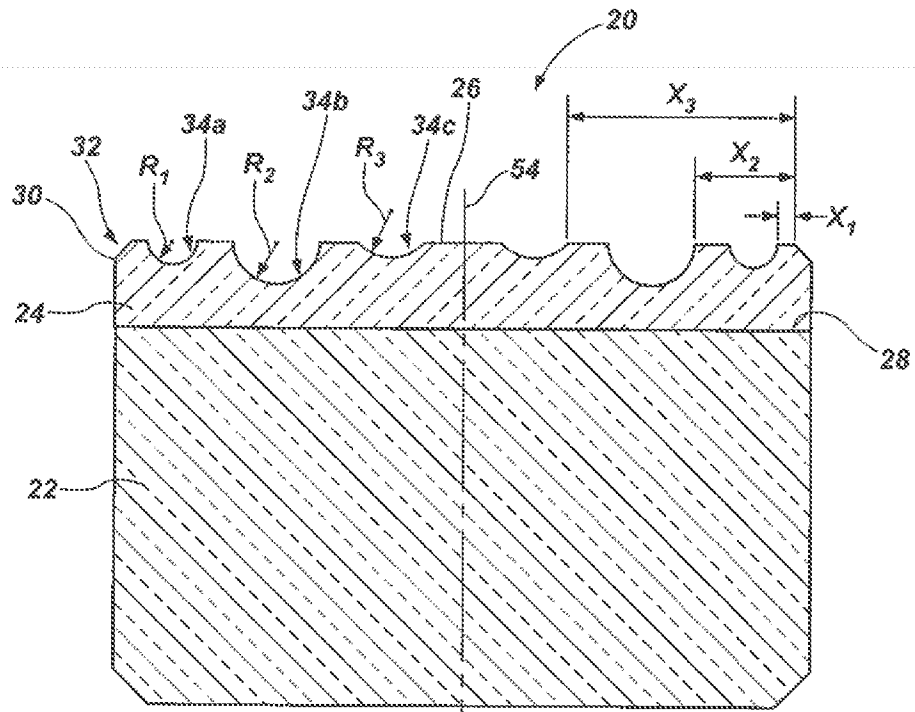

FIG. 19

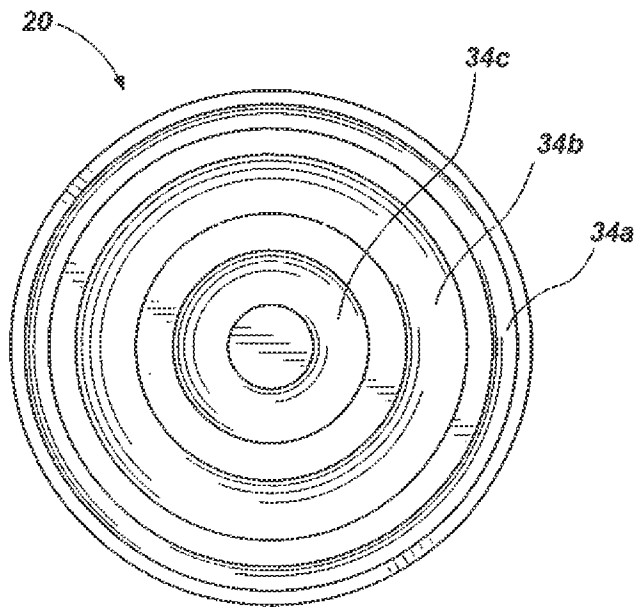

FIG. 20

+



7/12

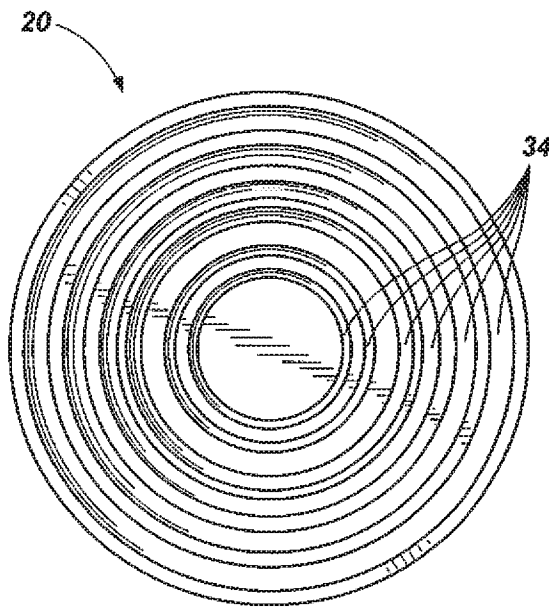

FIG. 21

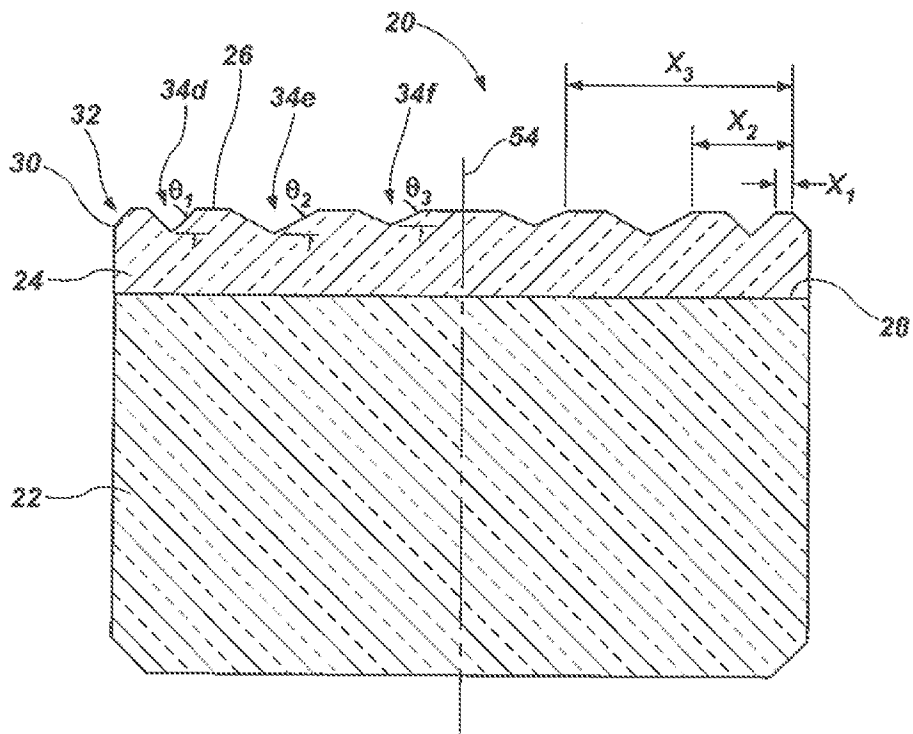

FIG. 22



+

8/12

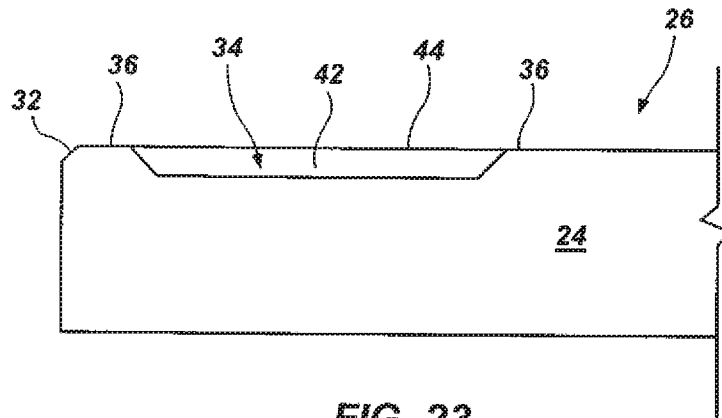

FIG. 23

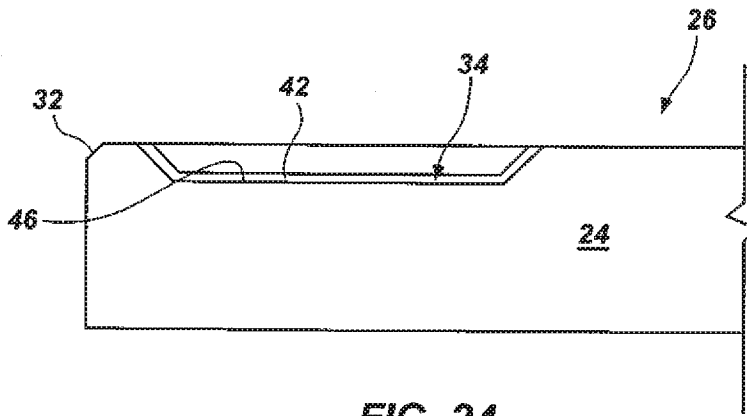

FIG. 24

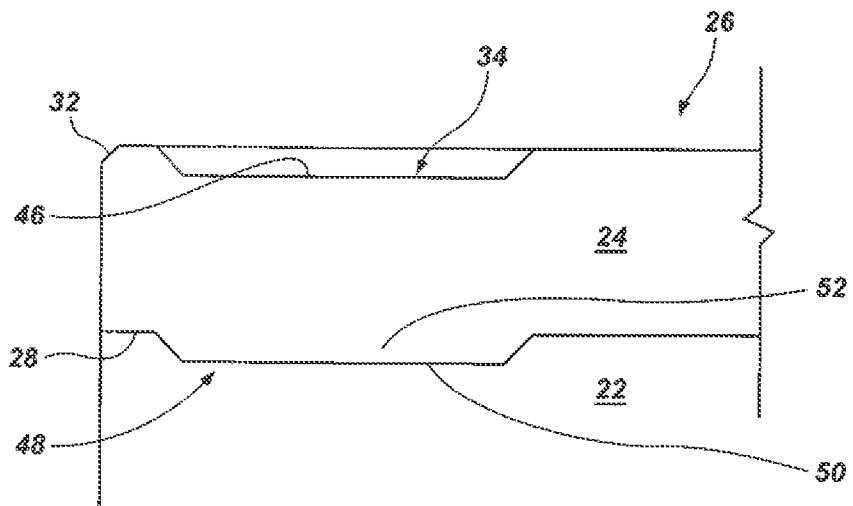

FIG. 25

+

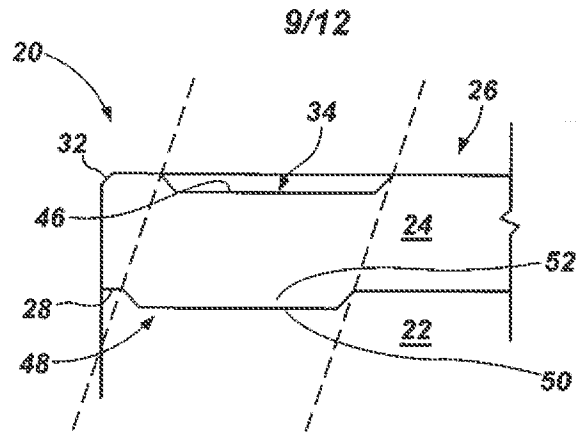

FIG. 26

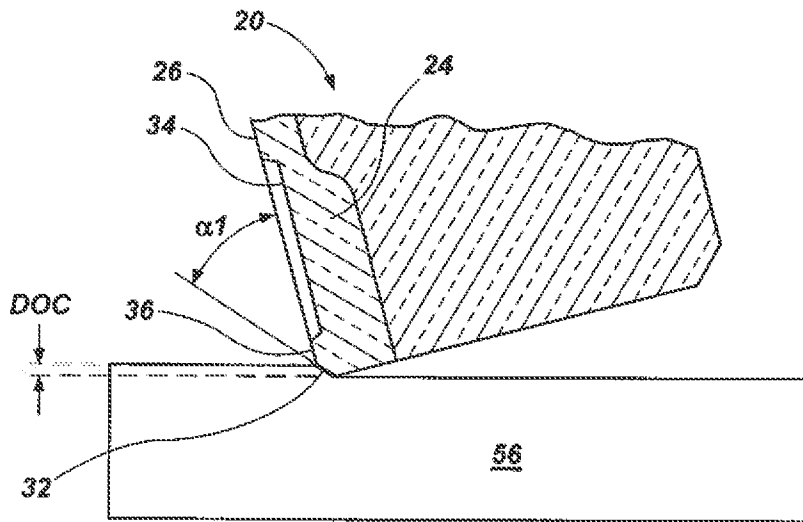

FIG. 27

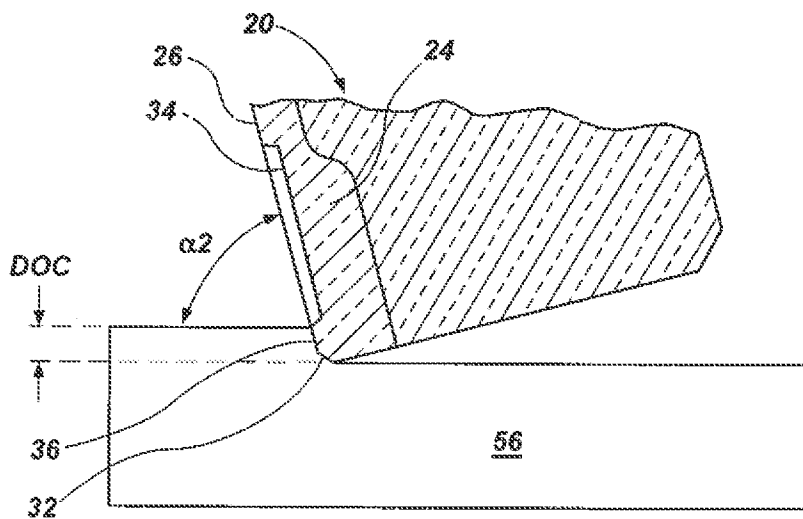

FIG. 28



+

10/12

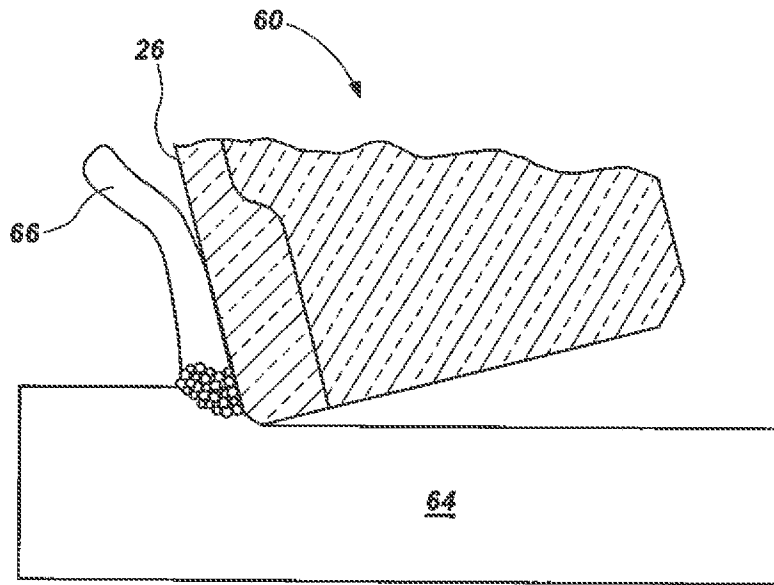

FIG. 29

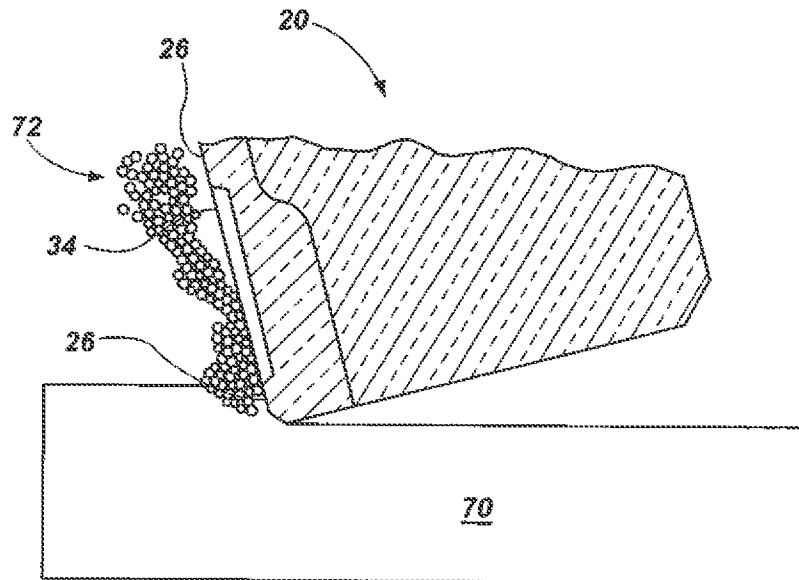

FIG. 30

+

+

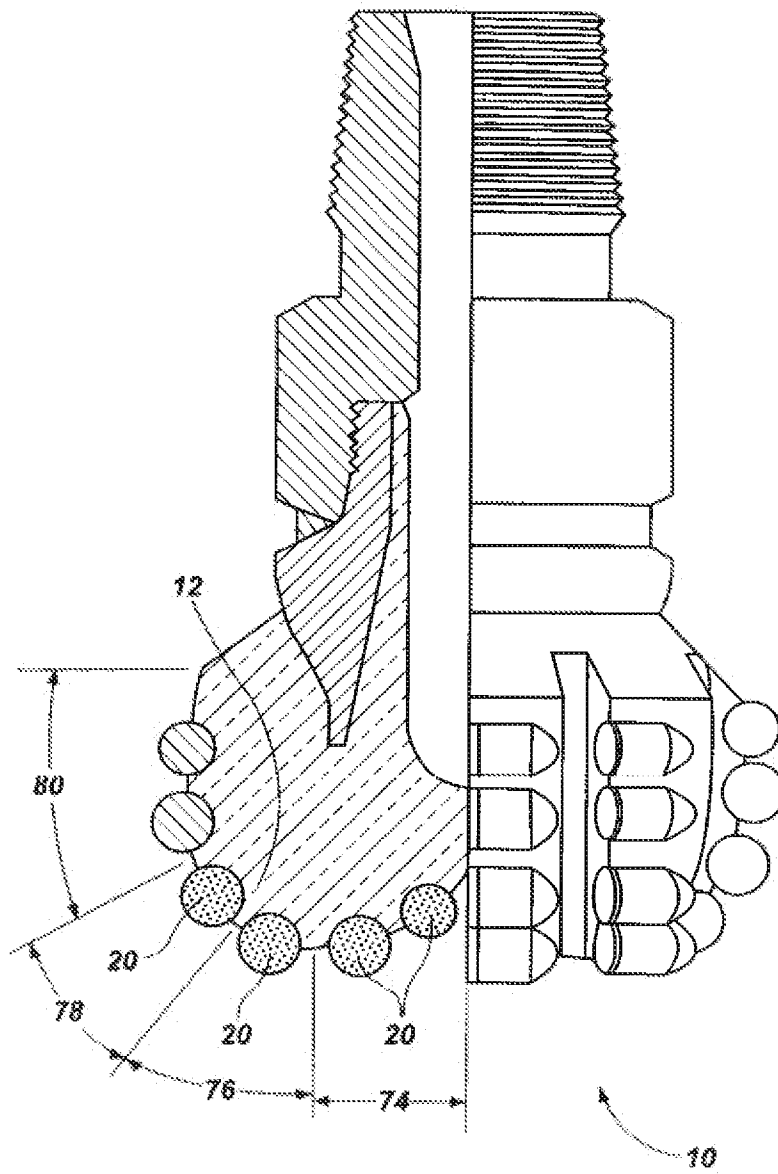

FIG. 31

+

+

12/12

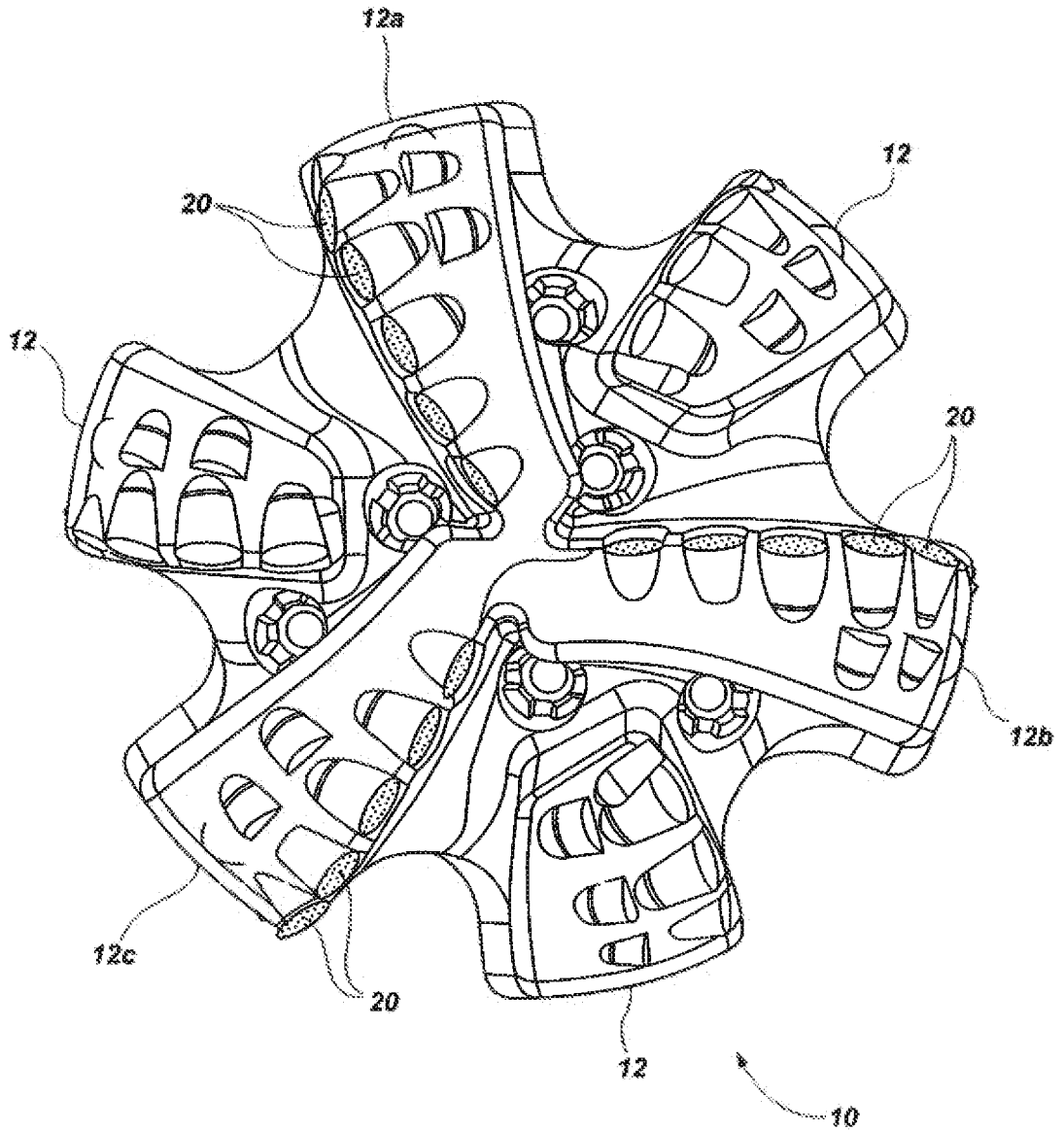

FIG. 32

+