



(11) **EP 3 239 603 A1**

(12) **EUROPEAN PATENT APPLICATION**
published in accordance with Art. 153(4) EPC

(43) Date of publication:
01.11.2017 Bulletin 2017/44

(51) Int Cl.:
F21V 19/00^(2006.01) F21V 29/00^(2015.01)

(21) Application number: **14904437.2**

(86) International application number:
PCT/RU2014/000999

(22) Date of filing: **26.12.2014**

(87) International publication number:
WO 2016/064295 (28.04.2016 Gazette 2016/17)

(84) Designated Contracting States:
AL AT BE BG CH CY CZ DE DK EE ES FI FR GB GR HR HU IE IS IT LI LT LU LV MC MK MT NL NO PL PT RO RS SE SI SK SM TR
Designated Extension States:
BA ME

(72) Inventor: **Sokolov, Yuriy Borisovich**
Moskovskaya obl. 141195 (RU)

(74) Representative: **Spengler, Robert**
Potthast & Spengler Patentanwälte
Küfergasse 11
89073 Ulm (DE)

(71) Applicant: **Sokolov, Yuriy Borisovich**
Moskovskaya obl. 141195 (RU)

(54) **LIGHT-EMITTING DIODE LAMP**

(57) The invention relates to lighting technology, and more particularly to light-emitting diode lamps having a printed circuit board and a screw cap (Edison cap) for connection to an electric power supply network. The technical result of the claimed invention is less labour-intensive installation, fewer structural and fastening components, and a simpler lamp design. A light-emitting diode lamp comprises a light diffuser; a housing; a screw cap; and a rectangular dielectric printed circuit board, which is mounted along the axis of the cap, wherein a portion of the printed circuit board is situated in the chamber of the cap and is provided with a perforation, the edge of which is provided with an electrically conductive coating capable of forming an electrical connection with the side surface of the cap and with the contact element of the cap

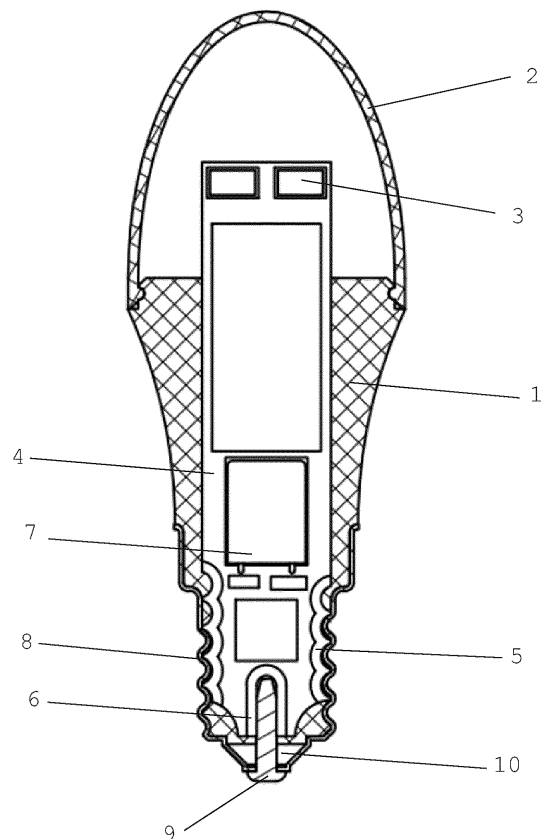

Fig.1

EP 3 239 603 A1

Description

•Technical field

[0001] The invention belongs to illuminating engineering, notably, to LED lamps, having a circuit board and a screw cap (Edison cap) for connection with electrical network.

•Prior art

[0002] Screw cap is the most widely spread means of connecting a LED lamp with an Edison screw holder of electrical network.

[0003] In many types of LED lamps circuit boards are used, where radio-electronic elements are located by means of printed circuit or space-wired interconnections, for example, elements of electronic inverter, necessary for ensuring a lighting unit operation.

[0004] Up to now the traditional method of connecting circuit board outputs with screw cap contacts is soldering of equipment wires.

[0005] It quite rarely happens, when decisions are suggested, which allow connection of a circuit board and a cap without soldering. But this leads to complication of the cap and equipment wires structure, which has a negative influence on the lighting unit workability and its price.

[0006] There is a LED lamp, consisting of light emitting diodes, mounted on a circuit board, equipment wires, with end of a certain shape and a screw cap, including contact elements, adapted for mechanical joint with the ends of equipment wires (KR10-1430021, MIIK F21V/23/00, issued 14.08.2014).

[0007] There is a lamp version with a power source, integrated into a screw cap, mounted on a circuit board, located across the axis of the screw cap. And circuit board outputs are connected via soldering with the screw cap contacts (WO2014/166367, MIIK H05B 37/02, issued 16.10.2014).

[0008] There is a LED lamp version, consisting of a circuit board with a power source and equipment wires; and a screw cap. And circuit board is located along the cap axis (KR 10-1415690, MIIK F21V29/00, issued 04.07.2014).

[0009] There is a general purpose LED lamp version, consisting of a screw cap, circuit board, installed along the cap axis, on the surface of which LEDs and a power source are mounted, electrically connected with the cap by equipment wires (WO2013109161, MIIK F21Y101/02, issued 24.07.2013).

[0010] The decision, revealed in the issued international claim WO2013109161, is accepted as a prototype, because it is the closest to the claimed decision according to the quantity of matching features.

[0011] The technical result of the claimed decision is decrease of mounting laboriousness, decrease of the quantity of structural and fastening elements, simplification of lamp structure.

•Disclosure of invention.

[0012] Claimed invention is characterized by the following group of features:

LED lamp, consisting of a light diffusor; case; cap, performed as a thin-walled cylinder with a bottom, on the side surface of which spiral coils are located, and on the bottom a contact element is fixed; rectangular dielectric circuit board, which is installed along the cap axis and electrically connected with the cap wall and its contact element, is characterized by the fact, that a part of a circuit board is located in the cap cavity and is provided with a perforation, the edges of which are coated with electrically conductive cover, performed with a possibility of electric connection with a side surface of the cap and with its contact element.

[0013] The perforation is made in three sides of the rectangular circuit board. Perforation in the opposite sides of the circuit board has a shape and stroke, corresponding to the shape and stroke of the cap spiral coils. One deepening of perforation, having an extended shape for fixing a contact element, along the short side of the board is enough.

[0014] A power source or a power source and light emitting diodes may be located on the circuit board.

[0015] Electrically conductive cover at the edges of perforation may be made by any available method of metallization.

[0016] In all versions the width of circuit board part is equal to the cap inner diameter.

•Brief description of drawings

[0017] The claimed decision is illustrated by the following drawings:

Fig.1 shows the version of a lamp with diodes on the board, fixed in the cap,
Fig.2 shows the version of a lamp with diodes on the auxiliary board,
Fig.3 shows the enlarged image of connection of a circuit board with a cap.

[0018] A LED lamp (fig.1) consists of a molded radiator-case 1, made of dielectric material; diffusor 2, fixed on the radiator-case 1; light emitting diodes 3, mounted on rectangular circuit board 4, provided with a perforation 5 on the side and a deepening 6 on the short side of the board; power source 7, cap 8, contact element 9 of cap 8.

[0019] Mounting of circuit board 4 inside cap 7 is performed by simple clockwise rolling the board firmly. And plated edges of perforation 5, located on the opposite sides of circuit board 4, ensure electric contact with the inner side surface of cap 8, and contact element 9 with deepening 6 on the short side of board 4. Dielectric ma-

terial of the molded radiator-case ensures reliable fixation of plate 4 and electrical safety of the lamp.

•Embodiments

5

[0020] A simple version of the claimed decision, showed in fig.1, consists of a molded radiator-case 1, made of dielectric material; diffusor 2, fixed on radiator-case 1; light emitting diodes 3, mounted on rectangular circuit board 4, equipped with perforation 5 on the side and deepening 6 on the short side of the board; power source 6, cap 7, contact element 8 of the cap, electric insulating layer 10 of the cap.

10

[0021] A version of LED lamp is possible, where light emitting diodes 3 are located on auxiliary circuit board 11, which is electrically connected with circuit board 4. Cooling of circuit boards 4 and 11 is performed by thermal contact with dielectric heat conducting radiator case 1.

15

•Possibility of industrial application

20

[0022] The technology of LED lamp elements manufacturing is known worldwide, well adapted and provided with productive machines of different degree of automation.

25

Claims

1. LED lamp, consisting of a light diffusor; case; cap, performed in the form of thin-walled cylinder with a bottom, on the side surface of which spiral coils are located, and a contact element is fixed at the bottom; a rectangular dielectric circuit board, which is installed along the cap axis and electrically connected with the cap wall and its contact element, **characterized by** the fact, that the part of the circuit board is located inside the cap cavity and is provided with perforation, edges of which are coated with electrically conductive cover, performed with a possibility of electric connection with the cap side surface and its contact element. 30 35 40
2. According to claim 1, LED lamp is **characterized by** the fact, that light emitting diodes and and/or a power source are mounted on the board. 45
3. According to claim 1, LED lamp is **characterized by** the fact, that the board with electronic components, fixed on it, is covered with the radiator material layer. 50

55

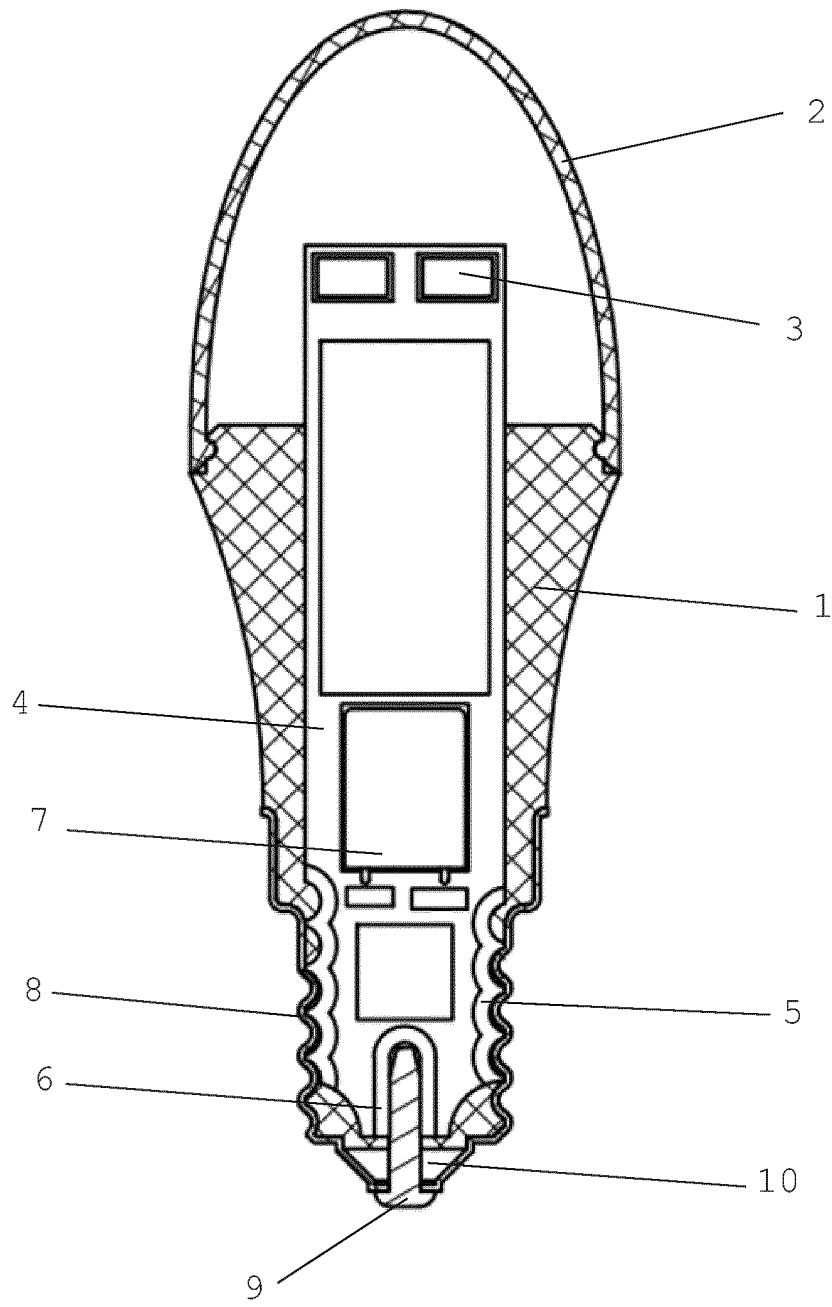

Fig.1

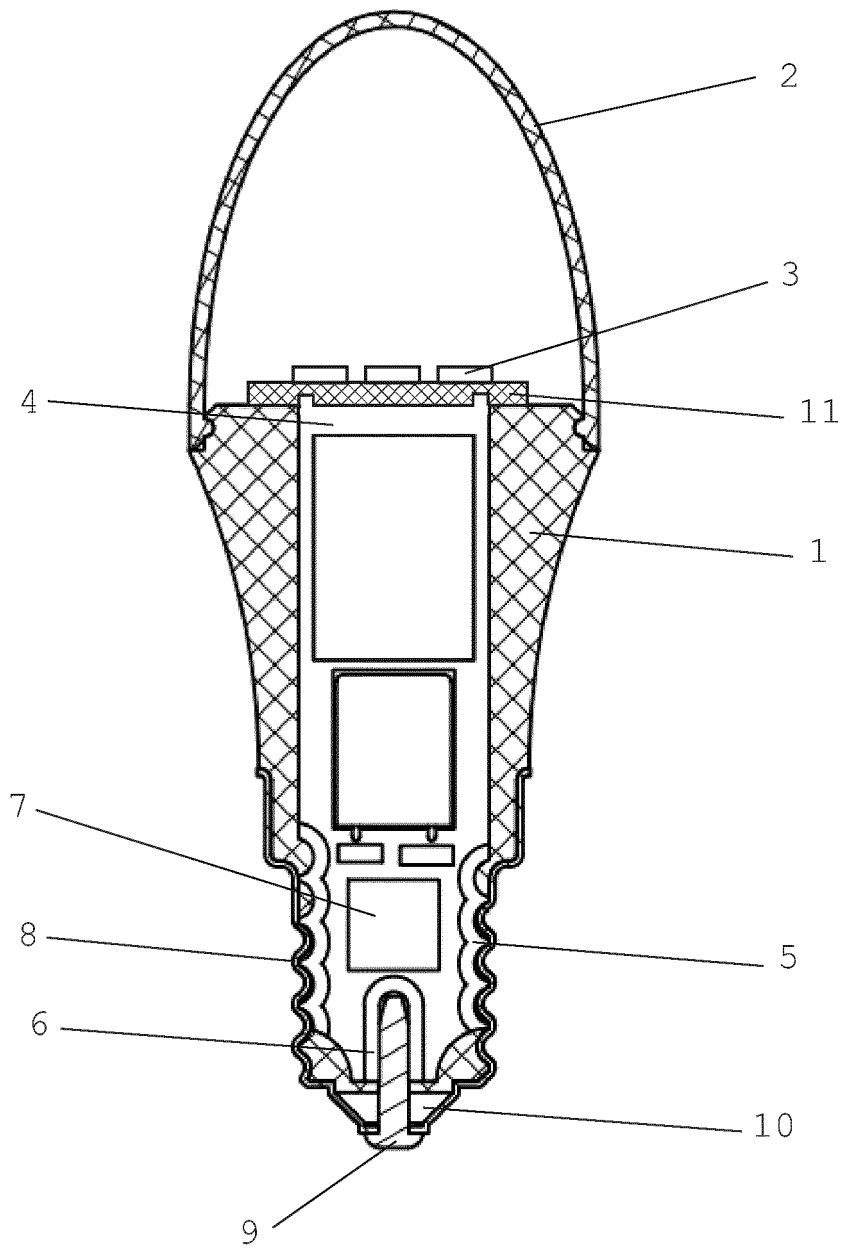

Fig.2

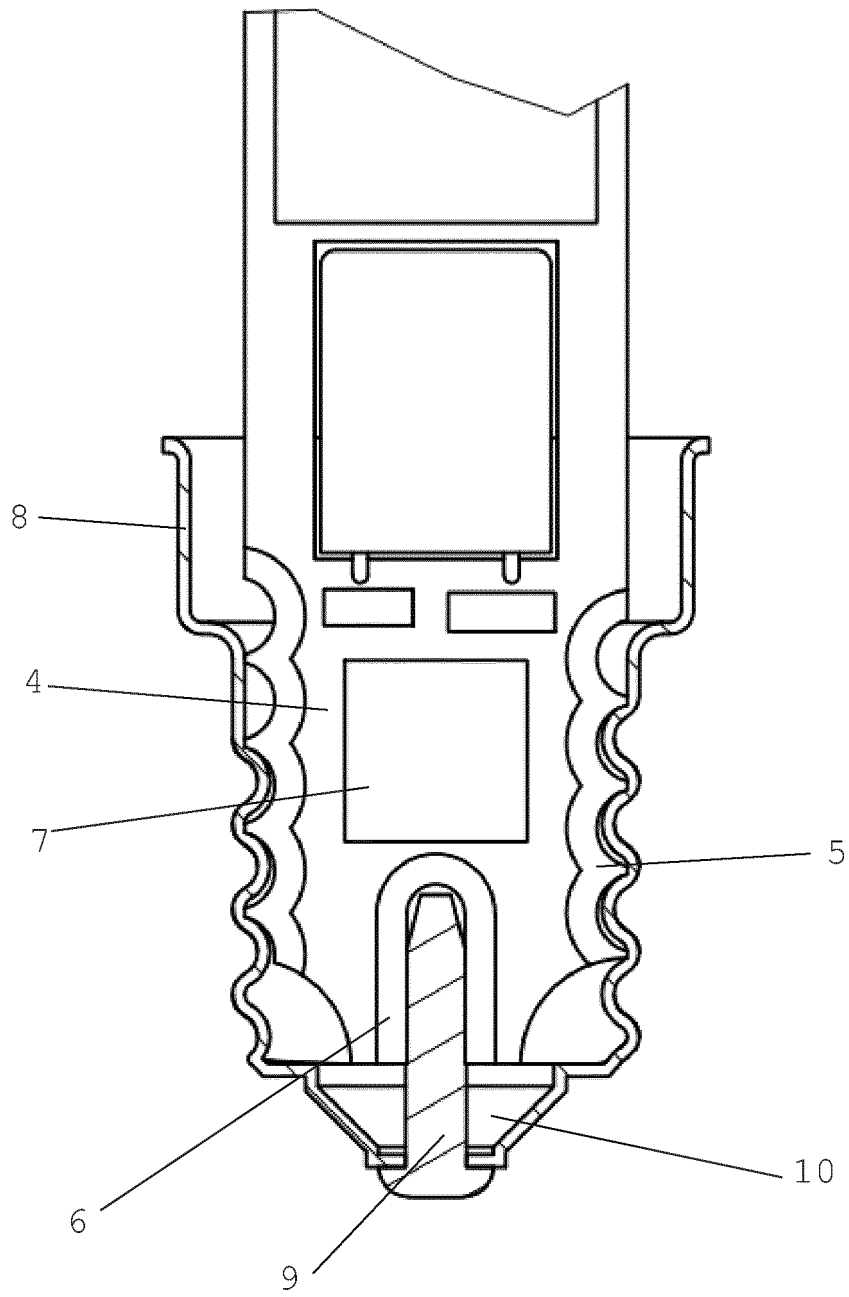

Fig.3

INTERNATIONAL SEARCH REPORT

International application No. PCT/RU 2014/000999

5	A. CLASSIFICATION OF SUBJECT MATTER F21V 19/00 (2006.01); F21V 29/00 (2006.01); F21Y 101/02 (2006.01) According to International Patent Classification (IPC) or to both national classification and IPC	
10	B. FIELDS SEARCHED Minimum documentation searched (classification system followed by classification symbols) F21S 2/00, H01L 25/00, 27/15, F21V 19/00, 23/00, 29/00, H05B 33/00, 37/02, F21Y 101/02 Documentation searched other than minimum documentation to the extent that such documents are included in the fields searched	
15	Electronic data base consulted during the international search (name of data base and, where practicable, search terms used) Espacenet, USPTO, CIPO, PatSearch	
20	C. DOCUMENTS CONSIDERED TO BE RELEVANT	
25	Category*	Citation of document, with indication, where appropriate, of the relevant passages
30		Relevant to claim No.
35	D, A	WO 2013/109161 A1 (OBSCHESTVO S OGRANICHENNOI OTVETSTVENNOSTIU «DIS PLIUS») 25.07.2013
40	D, A	KR 101415690 B1 (NAM DOO SEOK) 04.07.2014
45	A	RU 131236 U1 (KRASNOV NIKOLAI TITOVICH) 10.08.2013
50	A	RU 2504715 C2 (CHZHETSZIAN SETEK LAITING KO., LTD) 20.01.2014
55	<input type="checkbox"/> Further documents are listed in the continuation of Box C. <input type="checkbox"/> See patent family annex.	
	* Special categories of cited documents:	"T" later document published after the international filing date or priority date and not in conflict with the application but cited to understand the principle or theory underlying the invention "A" document defining the general state of the art which is not considered to be of particular relevance "E" earlier application or patent but published on or after the international filing date "L" document which may throw doubts on priority claim(s) or which is cited to establish the publication date of another citation or other special reason (as specified) "O" document referring to an oral disclosure, use, exhibition or other means "P" document published prior to the international filing date but later than the priority date claimed "X" document of particular relevance; the claimed invention cannot be considered novel or cannot be considered to involve an inventive step when the document is taken alone "Y" document of particular relevance; the claimed invention cannot be considered to involve an inventive step when the document is combined with one or more other such documents, such combination being obvious to a person skilled in the art "&" document member of the same patent family
	Date of the actual completion of the international search	Date of mailing of the international search report
	27 August 2015 (27.08.2015)	10 September 2015 (10.09.2015)
	Name and mailing address of the ISA/ RU	Authorized officer
	Facsimile No.	Telephone No.

REFERENCES CITED IN THE DESCRIPTION

This list of references cited by the applicant is for the reader's convenience only. It does not form part of the European patent document. Even though great care has been taken in compiling the references, errors or omissions cannot be excluded and the EPO disclaims all liability in this regard.

Patent documents cited in the description

- KR 101430021 [0006]
- WO 2014166367 A [0007]
- KR 101415690 [0008]
- WO 2013109161 A [0009] [0010]