

(19) World Intellectual Property Organization  
International Bureau



(43) International Publication Date  
22 May 2009 (22.05.2009)

PCT

(10) International Publication Number  
**WO 2009/062508 A1**

- (51) International Patent Classification:  
A61M 5/20 (2006.01)
- (21) International Application Number:  
PCT/DK2008/000399
- (22) International Filing Date:  
12 November 2008 (12.11.2008)
- (25) Filing Language: English
- (26) Publication Language: English
- (30) Priority Data:  
PA 2007 01596 12 November 2007 (12.11.2007) DK  
60/996,344 13 November 2007 (13.11.2007) US  
PA 2007 01867 21 December 2007 (21.12.2007) DK  
PA 2007 01869 21 December 2007 (21.12.2007) DK  
PA 2007 01870 21 December 2007 (21.12.2007) DK
- (71) Applicant (for all designated States except US): **BANG & OLUFSEN MEDICOM A/S** [DK/DK]; Gimsinglundvej 20, DK-7600 Struer (DK).
- (72) Inventors; and
- (75) Inventors/Applicants (for US only): **JOHANSEN, Esben, Weldingh** [DK/DK]; Sarpsborgvej 16, DK-7600 Struer (DK). **RASMUSSEN, Jørgen** [DK/DK]; Ydunsvej 6, NL-7600 Struer (DK). **MAEGAARD, Christian** [DK/DK]; Kongshøj Allé 61, DK-5300 Kerteminde (DK).

- HALD, Jørn, Winther [DK/DK]; Hindbaerhegnet 4, DK-7600 Struer (DK).
- (74) Agent: **ALBIHNS A/S**; Havneholmen 29, bygn. 2, 3. sal, DK-1561 Cøbenhavn V. (DK).
- (81) Designated States (unless otherwise indicated, for every kind of national protection available): AE, AG, AL, AM, AO, AT, AU, AZ, BA, BB, BG, BH, BR, BW, BY, BZ, CA, CH, CN, CO, CR, CU, CZ, DE, DK, DM, DO, DZ, EC, EE, EG, ES, FI, GB, GD, GE, GH, GM, GT, HN, HR, HU, ID, IL, IN, IS, JP, KE, KG, KM, KN, KP, KR, KZ, LA, LC, LK, LR, LS, LT, LU, LY, MA, MD, ME, MG, MK, MN, MW, MX, MY, MZ, NA, NG, NI, NO, NZ, OM, PG, PH, PL, PT, RO, RS, RU, SC, SD, SE, SG, SK, SL, SM, ST, SV, SY, TJ, TM, TN, TR, TT, TZ, UA, UG, US (patent), UZ, VC, VN, ZA, ZM, ZW.
- (84) Designated States (unless otherwise indicated, for every kind of regional protection available): ARIPO (BW, GH, GM, KE, LS, MW, MZ, NA, SD, SL, SZ, TZ, UG, ZM, ZW), Eurasian (AM, AZ, BY, KG, KZ, MD, RU, TJ, TM), European (AT, BE, BG, CH, CY, CZ, DE, DK, EE, ES, FI, FR, GB, GR, HR, HU, IE, IS, IT, LT, LU, LV, MC, MT, NL, NO, PL, PT, RO, SE, SI, SK, TR), OAPI (BF, BJ, CF, CG, CI, CM, GA, GN, GQ, GW, ML, MR, NE, SN, TD, TG).

Published:  
— with international search report

[Continued on next page]

(54) Title: AUTO INJECTOR WITH A ROTATABLE RELEASE SHAFT

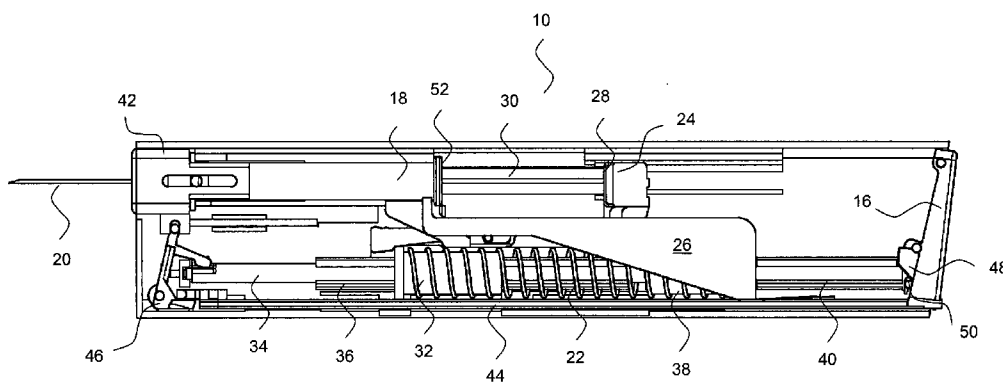

FIG. 16

(57) Abstract: A disposable auto injector (10) having a housing for accommodation of a syringe (18) with a needle movably positioned in the housing between a first position in which the needle is inside the housing and a second position in which the needle protrudes outside the housing, a driver (22) positioned laterally in relation to the syringe and configured for applying a force to the syringe thereby moving the syringe from the first position to the second position, a first injection lock configured in a locked state for preventing syringe movement from the first position to the second position and an injection trigger member (16) configured for releasing the first injection lock to an unlocked state wherein the first injection lock comprises a rotatable release shaft (34) configured for rotation between a first angular position in which it prevents movement of the syringe from the first position to the second position and a second angular position in which position does not prevent movement of the syringe from the first position to the second position.



WO 2009/062508 A1



- 
- *before the expiration of the time limit for amending the claims and to be republished in the event of receipt of amendments*

## AUTO INJECTOR WITH A ROTATABLE RELEASE SHAFT

The present invention relates to a disposable auto injector that can be safely operated for automatic injection of a dose of medication.

5 EP 1 349 590 discloses an auto injector with a housing that accommodates a syringe with a needle and has a needle cover surrounding the needle. Further, the housing accommodates spring means capable of, upon activation, pushing the needle through the needle cover as well as injecting the dose of medication. The auto injector further has first locking means capable of locking the spring means in a pressurized state, and first activating means capable of upon manual operation, releasing the spring means  
10 for injection. The first activating means can not be operated unless a contact part of the injector is actually pressed against the injection site. Thus, it is required to perform a two-step operation in order to inject the medication whereby inadvertent triggering of the auto injector is avoided.

In the disclosed auto injector construction, the syringe abuts and interacts with many  
15 other parts of the auto injector so that during manufacture of the auto injector, the syringe has to be mounted together with the other parts in a specific sequence that can not easily be changed. For some pharmaceutical companies it is desirable to be able to assemble the auto injector without the syringe at one site and subsequently mount the syringe with medication at another site.

20 Thus, there is a need for an alternative design of an auto injector.

According to the present invention the above-mentioned and other objects are fulfilled by provision of an auto injector with a housing for accommodation of a syringe with a needle, the syringe being movably positioned in the housing between a first position in which position the needle is accommodated inside the housing and a second position  
25 in which position the needle protrudes outside the housing, and a driver configured for applying a force to the syringe thereby moving the syringe from the first position to the second position.

The driver may be positioned laterally in relation to the syringe.

The auto injector may further comprise a rotatable release shaft rotatably mounted in  
30 the housing between at least two angular positions, preferably between at least three angular positions, for control of the sequence of operation of the auto injector.

For example, a first injection lock of the injector may be configured in a locked state for preventing syringe movement from the first position to the second position and an

injection trigger member may be configured for releasing the first injection lock to an unlocked state by user operation of the injection trigger member in which unlocked state the first injection lock does not prevent the driver from moving the syringe from the first position to the second position.

- 5 Advantageously, the first injection lock may comprise the rotatable release shaft mounted in the housing for rotation between a first angular position in which position movement of the syringe from the first position to the second position is prevented and a second angular position in which position movement of the syringe from the first position to the second position is not prevented.
- 10 Utilization of a rotatable shaft for controlling displacement of parts in the injector by locking the position of specific parts in one angular position of the shaft and unlocking the position of the specific parts in another angular position of the shaft makes the device more resistant to possible user dropping of the device.

In prior art devices, locking and unlocking displacement of parts in the auto injector by  
15 linear movement of locking parts is inherently sensitive to dropping of the device, since such dropping may induce a linear movement of parts in the device, e.g. causing inadvertent triggering of the device. In the auto injector according to the invention, dropping of the device will not turn the rotatable shaft, and since the auto injector can not be dropped on the injection trigger member and the release member  
20 simultaneously, the device will not inadvertently be triggered by dropping of the device.

Preferably, the rotatable release shaft is positioned laterally in relation to the syringe.

The driver may be an electro-mechanical driver, e.g. comprising an electromotor, a piezoelectric transducer, etc, a pneumatic driver, a hydraulic driver, a mechanical driver, such as a spring, such as a coil spring, a constant force spring, etc, etc.

- 25 A spring may be arranged coaxially with the rotatable release shaft for further size reduction of the injector.

The injection trigger member may be coupled to the rotatable release shaft and configured to turn the release shaft from the first angular position to the second angular position by user operation.

- 30 For example, the injection trigger member may have a flange that abuts a tap protruding from the release shaft perpendicular to the longitudinal axis of the release shaft in such a way that movement of the injection trigger member with the flange displaces the tap thereby turning the release shaft an angle from the first angular position to the second angular position.

The injector may further comprise a movable member configured with a first ring positioned in such a way that the release shaft extends through the first ring, and wherein the release shaft has first tongues protruding from the release shaft and extending in parallel with the longitudinal axis of the release shaft with end edges abutting the first ring in one angular position of the release shaft thereby preventing the first ring from moving in the direction of the first tongues.

The first ring may have through-going grooves in its inner circular circumferential surface abutting the release shaft positioned in such a way that the first tongues of the release shaft in another angular position of the release shaft fit respective through-going grooves in the inner circular circumferential surface of the first ring, the grooves being sized to accommodate the tongues thereby allowing the first ring to slide along the release shaft with the tongues sliding in the grooves so that the first ring can be displaced in the direction of the first tongues.

The movable member may comprise a first arm connected to the first ring for conveying a force from the driver to the syringe plunger end for moving the syringe from the first position to the second position.

For example, in the first angular position of the release shaft, the driver may urge the first ring against the edges of the first tongue whereby the syringe is kept in its first position, while in the second angular position, the first tongues fit respective through-going grooves in the first ring so that the first ring is allowed to slide along the release shaft driven by the driver whereby the syringe is moved to its second position.

Preferably, the driver is further configured for pushing the syringe plunger further into the syringe thereby supplying a dose of medicament contained in the syringe.

In the housing of the auto injector, two parts are laterally positioned in relation to each other when they are positioned by the side of each other. For example, two elongated parts, each of which extends along a longitudinal axis, are laterally positioned in relation to each other when their individual longitudinal axes do not coincide.

The lateral arrangement of the syringe with relation to the driver and the rotatable release shaft makes it possible to mount the syringe in the device at various selected stages of assembly of the auto injector. For example, it is possible to assemble the auto injector at one site and subsequently mount the syringe with the medicament at another site which again makes it possible for a pharmaceutical company to buy an assembled auto injector for use with their own syringe with medicament so that

handling of the syringe with medicament is kept within the premises of the pharmaceutical company.

Further, the lateral arrangement leads to the advantage that space is available in the housing of the auto injector for accommodation of drivers of various sizes and shapes and thus, different models of the auto injector fulfilling different requirements may be provided with limited effort.

For example, in an embodiment with a coil spring driver, coil springs of different thickness and number of turns and shape, e.g. conical coil springs, etc, may be arranged in the housing of the auto injector for provision of different forces, displacements, and forces varying as a predetermined function of time, etc, suitable for different types of injections.

In a prior art injector, components of the injector are arranged both inside the coil spring and outside the coil spring so that geometrical dimensions of the coil spring can not easily be changed in order to obtain another force and/or displacement by the coil. The lateral arrangement according to the invention makes it possible to utilize drivers of different geometries.

The auto injector may further be configured for user operation in a certain sequence in which triggering of an injection is only possible for example when the injector is pressed against the injection site.

Thus, the auto injector may further comprise a second injection lock configured in a locked state for preventing syringe movement from the first position to the second position by user operation of the injection trigger member and a release member configured for releasing the second injection lock to an unlocked state by first user operation of the release member in which unlocked state the second injection lock does not prevent syringe movement from the first position to the second position by user operation of the injection trigger member.

The release member may be configured for abutment with the injection site during use, and first user operation may be constituted by the user pressing the release member against the injection site.

The second injection lock may be configured in the locked state to prevent user operation of the injection trigger member.

The auto injector may further be configured for automatically retracting the needle back into the housing upon termination of injection of medication, for example immediately

upon removal of the auto injector from the injection site, in order to avoid inadvertent contact with the used needle.

The driver may further be configured for retracting the syringe from the second position to a retracted position in which the needle does not protrude from the housing.

- 5 The auto injector may further comprise a retraction lock for prevention of retraction of the syringe in a locked state.

The release member may further be configured for releasing the retraction lock to an unlocked state by second user operation of the release member thereby allowing the driver to retract the syringe.

- 10 The second user operation of the release member may be constituted by the user removing the release member from the injection site.

The release shaft may further be configured for rotation between a third angular position in which position the shaft prevents movement of the syringe from the second position to the retracted position and a fourth angular position in which position the shaft does not prevent movement of the syringe from the second position to the retracted position.

- 15 The release shaft may further have second tongues protruding from the release shaft and extending in parallel with the longitudinal axis of the release shaft and displaced along the longitudinal axis of the release shaft in relation to the first tongues with end edges abutting a second ring in the other angular position of the release shaft thereby preventing the second ring from moving in the direction of the second tongues.

- 20 Through-going grooves of the second ring fit respective second tongues in a third angular position of the release shaft and the grooves are sized to accommodate the second tongues thereby allowing the second ring to slide along the release shaft with the second tongues sliding in the grooves so that the second ring can be displaced in the direction of the second tongues.

25 The third angular position may be identical to the second angular position.

- The auto injector may further comprise a second arm connected to the second ring for conveying a force from the driver to the syringe shoulder for retracting the syringe from the second position to the retracted position.

30 For example, the driver may be a mechanical driver that may be anchored to the housing at a first anchor location for applying force to the syringe thereby moving the syringe from the first position to the second position. Further, the mechanical driver

may be anchored at a different second anchor location for applying force to the syringe thereby moving the syringe from the second position to the retracted position in which position the needle is accommodated inside the housing.

Utilisation of a single mechanical driver for moving the syringe in a forward direction  
5 from its first position to its second position and also for moving the syringe in the  
opposite direction from its second position to its retracted position provides a simple  
drive mechanism for retraction of the syringe into the housing after the injection.

The above and other features and advantages of the present invention will become  
readily apparent to those skilled in the art by the following detailed description of  
10 exemplary embodiments thereof with reference to the attached drawings, in which:

Fig. 1 shows an auto injector according to the invention with a protection cap,

Fig. 2 shows the auto injector of Fig. 1 in a state ready for use and with a part of the  
housing cut away,

Fig. 3 shows the auto injector of Fig. 2 with the protection cap removed,

15 Fig. 4 shows the auto injector of Fig. 2 with the release member activated,

Fig. 5 shows the auto injector of Fig. 2 with the injection trigger member activated,

Fig. 6 shows the auto injector of Fig. 2 with the syringe moved to its second position,

Fig. 7 shows the auto injector of Fig. 2 with the syringe emptied,

Fig. 8 shows the auto injector of Fig. 2 with the release member released,

20 Fig. 9 shows the auto injector of Fig. 2 with the retraction lock released,

Fig. 10 shows the auto injector of Fig. 2 with the syringe retracted,

Fig. 11 shows an auto injector according to the invention with a protection cap,

Fig. 12 shows the auto injector of Fig. 11 in a state ready for use and with a part of the  
housing cut away,

25 Fig. 13 shows the auto injector of Fig. 12 with the protection cap removed,

Fig. 14 shows the auto injector of Fig. 12 with the release member activated,

Fig. 15 shows the auto injector of Fig. 12 with the injection trigger member activated,

Fig. 16 shows the auto injector of Fig. 12 with the syringe moved to its second  
position,

30 Fig. 17 shows the auto injector of Fig. 12 with the syringe emptied,

Fig. 18 shows the auto injector of Fig. 12 with the release member released,

Fig. 19 shows the auto injector of Fig. 12 with the retraction lock released, and

Fig. 20 shows the auto injector of Fig. 12 with the syringe retracted.

The figures are schematic and simplified for clarity, and they merely show details,  
5 which are essential to the understanding of the invention, while other details have been left out. Throughout, the same reference numerals are used for identical or corresponding parts.

It should be noted that in addition to the exemplary embodiments of the invention shown in the accompanying drawings, the invention may be embodied in different  
10 forms and should not be construed as limited to the embodiments set forth herein.

Rather, these embodiments are provided so that this disclosure will be thorough and complete, and will fully convey the concept of the invention to those skilled in the art.

Fig. 1 shows an auto injector 10 according to the present invention. It has an elongated housing 12 with a substantially rectangular cross-section for an easy grip by hand. The  
15 illustrated embodiment may for example have a length of 10 cm, a width of 3 cm, and a thickness of 1.5 cm. The housing 12 has an opening at one end thereof closed by a removable protection cap 14. At the opposite end of the housing is a trigger button 16 that serves as the injection trigger member as further explained below.

Fig. 2 shows the auto injector of Fig. 1 with a top part of the housing 12 removed. The  
20 housing 12 accommodates a syringe 18 with a needle 20 (not visible). The syringe 18 is positioned in a first position with the needle 20 accommodated within the walls of the housing 12.

In the illustrated embodiment, a coil spring 22 serves as the driver for moving the syringe 18 from the first position, in which position the needle is accommodated inside  
25 the housing, to a second position in which position the needle protrudes outside the housing. The coil spring 22 is positioned laterally in relation to the syringe 18 and is compressed so that it applies a force between a first arm, i.e. the plunger arm 24, and a second arm, i.e. the shoulder arm 26. One end of the plunger arm 24 abuts the end 28 of the plunger 30 of the syringe 18 while the other end is configured with a first ring  
30 32. A rotatably mounted release shaft 34 extends through the first ring 32. Protrusions or tongues 36 protruding from the release shaft 34 and extending in parallel with the longitudinal axis of the release shaft 34 have end edges abutting the first ring 32 and preventing the ring from moving to the left in Fig. 2 in response to the force exerted by the coil spring 22. Likewise, one end of the shoulder arm 26 is configured with a

second ring 38. The release shaft 34 also extends through the second ring 38. Other protrusions or tongues 40 protruding from the release shaft 34 and extending in parallel with the longitudinal axis of the release shaft 34 have end edges abutting the second ring 38 and preventing the second ring 38 from moving to the right in Fig. 2 in response to the force exerted by the coil spring 22. Thus, the end edges of the tongues 40 abutting the second ring 38 form the first anchor location.

In Fig. 3, the protection cap 14 has been removed from the auto injector 10 thereby exposing a skin contact button 42 intended to be pressed against the injection site during use and serving as the release member as will be further explained below.

10 Typically, the syringe 18 also has a rubber cap (not shown) for protection of the needle 20 in which case the protection cap 14 has fingers gripping an edge of the rubber cap so that the rubber cap is removed together with the protection cap 14.

A lock arm 44 has an end that abuts the trigger button 16 so that the user is prevented from depressing the trigger button and thus, from starting automatic injection.

15 Fig. 4 shows the auto injector 10 with the skin contact button 42 depressed whereby the lock arm 44 is released so that it is no longer kept in a fixed position by the pivotally mounted locking member 46. Depression of the trigger button 16 is now possible. Thus, in accordance with the invention, the auto-injector has a second injection lock configured in a locked state for preventing syringe movement from the first position to the second position by user operation of the injection trigger member and a release member configured for releasing the second injection lock to an unlocked state by first user operation of the release member in which unlocked state the second injection lock does not prevent syringe movement from the first position to the second position by user operation of the injection trigger member. In the illustrated example, first user operation of the release member is constituted by the user pressing the release member against the skin surface at the injection site.

In the illustrated embodiment, the second injection lock comprises the lock arm 44 and the pivotally mounted locking member 46. In the locked state shown in Fig. 3, the second injection lock prevents user operation of the injection trigger member, i.e. the trigger button 16 in the illustrated embodiment, thereby preventing syringe movement from the first position to the second position by user operation of the trigger button 16. The release member, i.e. the skin contact button 42 in the illustrated embodiment, when pressed against the injection site, releases the second injection lock to an unlocked state allowing depression of the trigger button 16 by turning the locking member 46 so that one end thereof abutting an end of the lock arm 44 moves away

from the lock arm so that the lock arm 44 can be displaced together with together with the trigger button 16, and thus, no longer prevents the trigger button 16 from being depressed.

Fig. 5 shows the auto injector 10 with both the skin contact button 42 and the trigger button 16 depressed. The trigger button 16 has a protruding flange 48 that abuts a tap 50 protruding from the release shaft 34 perpendicular to its longitudinal axis. When the trigger button 16 is depressed, the protruding flange 48 displaces the tap 50 thereby turning the release shaft 34 an angle of approximately 30° from a first angular position to a second angular position. This turns the tongues 36 of the release shaft 34 into second angular positions fitting corresponding through-going grooves (not visible) inside the first ring 32 of the plunger arm 24. The grooves are sized to accommodate the tongues 36 thereby allowing the ring to slide along the release shaft 34 with the tongues 36 sliding inside the grooves thereby releasing the plunger arm from its fixed position so that the plunger arm 24 is displaced to the left in the Figures in response to the force of the coil spring 22. The moved plunger arm 24 pushes the plunger 30 and thereby the syringe 18 towards its second position.

Thus, in accordance with the invention, the auto injector has a first injection lock configured in a locked state for preventing syringe movement from the first position to the second position and an injection trigger member configured for releasing the first injection lock to an unlocked state by user operation of the injection trigger member in which unlocked state the first injection lock does not prevent the driver from moving the syringe from the first position to the second position.

In the illustrated embodiment, the first injection lock of the illustrated embodiment comprises the release shaft 34 with tongues 36 interacting with the corresponding grooves (not visible) in the first ring 32 of the plunger arm 24. In the locked state, the release shaft 34 has a first angular position in which end edges of the tongues 36 abut the first ring 32 and prevent movement of the plunger arm 24. Depression of the injection trigger member, i.e. the trigger button 16 in the illustrated embodiment, releases the first injection lock by the turn of the release shaft 34 as explained above.

Fig. 6 shows the syringe 18 in its second position wherein the shoulder 52 of the syringe 18 abuts an end of the shoulder arm 26 and an internal protrusion in the housing 12. In the second position of the syringe 18, the needle 20 is exposed through an aperture in the skin contact button 42.

As shown in Fig. 7, the plunger arm 24 continues its movement while the syringe 18 is kept in its second position whereby the syringe 18 is emptied and the medication is

injected into the user. The plunger arm 24 is prevented from further movement to the left by abutment with the retraction lock arm 54 which again abuts the pivotable locking member 46 and a guiding protrusion 56 of the skin contact button 42.

5 Upon injection, the user removes the auto injector 10 from the injection site. During removal from the injection site, the syringe 18 is automatically retracted from its second position so that the needle 20 is withdrawn into the housing 12 and kept within the walls of the housing 12 thereby preventing accidental contact with the needle 20.

10 In Fig. 8, the auto injector 10 has been removed from the injection site and a resilient member such as a coil spring has forced the skin contact button 42 back to its original position shown in Figs. 1 – 3. The corresponding displacement of the guiding protrusion 56 of the skin contact button 42 allows the pivotally mounted retraction lock arm 54 to pivot away from the first ring 32 of the plunger arm 24 in response to the force exerted by the coil spring 22 on first ring 32. Since the first ring 32 abuts a skew edge of the retraction lock arm 54 further movement of the first ring 32 to the left in the  
15 Figure is now possible by pivoting the retraction lock arm 54 away from the first ring 32.

This is shown in Fig. 9. Pivoting the retraction lock arm 54 also disconnects the first ring 32 from the remaining part of the plunger arm 24 so that the plunger arm 24 is free to move back to the right together with the syringe 18. Simultaneous with the pivoting of the plunger arm 24 and further explained below, the first ring 32 turns the release shaft 34 an angle whereby the shoulder arm 26 with the second ring 38 is released  
20 from its fixed position and since the first ring 32 is now kept in a fixed position at the second anchor location, the coil spring 22 urges the second arm, i.e. the shoulder arm 26 with the second ring 38 in the illustrated embodiment, to the right in the Figures and thereby retracts the syringe 18 by its shoulder 52 to its original first position constituting  
25 the retracted position of the syringe 18. In the retracted position, the needle 20 is no longer exposed to the surroundings thereby avoiding health hazards and allowing disposal of the used auto injector.

Further turning of the release shaft 34 by the first ring 32 is possible because the length of the tongues 36 is shorter than the displacement of the first ring 32 so that the  
30 grooves of the first ring 32 do not accommodate the tongues 36 in the position shown in Fig. 7. Then, the turning of release shaft 34 is obtained in a way similar to the turning of the release shaft 34 by the trigger button 16 as previously explained. Thus, the first ring 32 has an indentation with a skew edge that displaces a second tap (not visible) protruding from the release shaft 34 perpendicular to its longitudinal axis during its final  
35 movement towards the left of Fig. 7 thereby turning the release shaft 34 another 30°.

This causes the tongues 40 at the right end of the release shaft 34 to be turned and aligned with corresponding through-going grooves in the second ring 38 of the shoulder arm 26. The grooves (not visible) are sized to accommodate the tongues 40 so that movement of the shoulder arm 26 to the right of the Figure is made possible and thus, the coil spring 22 urges the shoulder arm 26 abutting the shoulder 52 of the syringe 18 to the right thereby retracting the syringe 18 back into its first position as shown in Fig. 10.

Thus, in accordance with the invention, the auto injector comprises a retraction lock for prevention of retraction of the syringe in a locked state of the retraction lock. In the illustrated embodiment, the retraction lock comprises the locking member 46, the guiding protrusion 56, the retraction lock arm 54, and the release shaft 34 with the tongues 40. The release member, i.e. the skin contact button 42 in the illustrated embodiment, is configured for releasing the retraction lock to an unlocked state by second user operation of the release member, i.e. removal of the auto injector from the injection site thereby releasing the skin contact button 42 from its depressed position to its original position. In its original position, the guiding protrusion 56 is displaced a distance from the retraction lock arm 54 so that the retraction lock arm can turn away from the first ring 32 allowing further movement of the first ring 32 to the left releasing the shoulder arm for movement to the right as explained above.

Upon removal of the auto injector 10 from the injection site, it is not possible to depress the skin contact button 42 again.

It should be noted that the auto injector may be constructed for making injections in more than one step. For example, in a dual chamber syringe, one chamber may contain freeze-dried medicine and a second chamber may contain liquid to be mixed with the freeze-dried medicine. A first actuation of the auto injector may lead to breakage of a seal between the first and second chambers bringing the liquid in contact with the freeze-dried medicine and a second actuation may lead to injection of the mixed medicine. For example, the release shaft 34 in the illustrated embodiment may contain more than two sets of tongues to be aligned with corresponding grooves in the respective rings 32, 38 at respective different angular positions of the release shaft 34 thereby allowing one of the rings 32, 38 to be displaced a predetermined distance when the release shaft 34 has a specific angular position. This makes it possible to use medicine without preservatives which again makes the auto injector more user friendly because most of the pain caused by injections is caused by preservatives in the wound.

It should further be noticed that utilization of a rotatable shaft for controlling displacement of parts in the auto injector by locking the position of specific parts in one angular position of the shaft and unlocking the position in another angular position of the shaft makes the device more resistant to the user dropping the device.

- 5 In prior art devices, locking and unlocking displacement of parts in the auto injector by linear movement of locking parts is inherently sensitive to dropping of the device, since such dropping may induce a linear movement of parts in the device, e.g. causing inadvertent triggering of the device. In the auto injector according to the invention,
- 10 dropping of the device will not cause rotation of the rotatable shaft, and since the auto injector can not be dropped on the injection trigger member and the release member simultaneously, the device will not inadvertently be triggered by dropping of the device.

Figs. 11 – 20 correspond to Figs. 1 – 10, respectively, and illustrate the operation of another auto injector according to the invention operating in a way similar to the auto injector illustrated in Figs 1 – 10 and explained above.

## CLAIMS

1. An auto injector with a housing for accommodation of  
a syringe with a needle, the syringe being movably positioned in the housing between a  
first position in which position the needle is accommodated inside the housing and a  
5 second position in which position the needle protrudes outside the housing,  
a driver positioned laterally in relation to the syringe and configured for applying a force  
to the syringe thereby moving the syringe from the first position to the second position,  
a first injection lock configured in a locked state for preventing syringe movement from  
the first position to the second position and  
10 an injection trigger member configured for releasing the first injection lock to an  
unlocked state by user operation of the injection trigger member in which unlocked  
state the first injection lock does not prevent the driver from moving the syringe from  
the first position to the second position,  
c h a r a c t e r i z e d in that the first injection lock comprises  
15 a rotatable release shaft configured for rotation between a first angular position in  
which position the shaft prevents movement of the syringe from the first position to the  
second position and a second angular position in which position the shaft does not  
prevent movement of the syringe from the first position to the second position.
2. An auto injector with a housing for accommodation of  
20 a syringe with a needle, the syringe being movably positioned in the housing between a  
first position in which position the needle is accommodated inside the housing and a  
second position in which position the needle protrudes outside the housing,  
a driver configured for applying a force to the syringe thereby moving the syringe from  
the first position to the second position,  
25 c h a r a c t e r i z e d in that the auto injector further comprises  
a rotatable release shaft rotatably mounted in the housing between at least three  
angular positions, for control of the sequence of operation of the auto injector.
3. An auto injector according to claim 2, further comprising  
a first injection lock configured in a locked state for preventing syringe movement from  
30 the first position to the second position,

an injection trigger member configured for releasing the first injection lock to an unlocked state by user operation of the injection trigger member in which unlocked state the first injection lock does not prevent the driver from moving the syringe from the first position to the second position, and wherein the first injection lock comprises

5 the rotatable release shaft configured for rotation between a first angular position in which position the shaft prevents movement of the syringe from the first position to the second position and a second angular position in which position the shaft does not prevent movement of the syringe from the first position to the second position.

10 4. An auto injector according to any of the preceding claims, wherein the rotatable release shaft is positioned laterally in relation to the syringe.

5. An auto injector according to any of the preceding claims, wherein the injection trigger member is coupled to the rotatable release shaft and configured to turn the release shaft from the first angular position to the second angular position by user operation.

15 6. An auto injector according to claim 5, wherein the injection trigger member has a flange that abuts a tap protruding from the release shaft perpendicular to the longitudinal axis of the release shaft in such a way that movement of the injection trigger member with the flange displaces the tap thereby turning the release shaft an angle from the first angular position to the second angular position.

20 7. An auto injector according to any of the preceding claims, wherein the driver is further configured for retracting the syringe from the second position to a retracted position in which the needle does not protrude from the housing, and wherein the release shaft is further configured for rotation between a third angular position in which position movement of the syringe from the second position to the retracted position is prevented and a fourth angular position in which position movement of the syringe from  
25 the second position to the retracted position is not prevented.

30 8. An auto injector according to any of the preceding claims, further comprising a movable member configured with a first ring positioned in such a way that the release shaft extends through the first ring, and wherein the release shaft has first tongues protruding from the release shaft and extending in parallel with the longitudinal axis of the release shaft with end edges abutting the first ring in one angular position of the release shaft thereby preventing the first ring from moving in the direction of the first tongues.

9. An auto injector according to claim 8, wherein the first ring has through-going grooves in its inner circular circumferential surface abutting the release shaft positioned in such a way that the first tongues of the release shaft in another angular position of the release shaft fit respective through-going grooves in the inner circular
- 5 circumferential surface of the first ring, the grooves being sized to accommodate the tongues thereby allowing the first ring to slide along the release shaft with the tongues sliding in the grooves so that the first ring can be displaced in the direction of the first tongues.
10. An auto injector according to claim 9, wherein the release shaft has second
- 10 tongues protruding from the release shaft and extending in parallel with the longitudinal axis of the release shaft and displaced along the longitudinal axis of the release shaft in relation to the first tongues and having end edges abutting a second ring in the other angular position of the release shaft thereby preventing the second ring from moving in the direction of the second tongues.
- 15 11. An auto injector according to claim 10, wherein through-going grooves of the second ring fit respective second tongues in a third angular position of the release shaft, the grooves being sized to accommodate the second tongues thereby allowing the ring to slide along the release shaft with the second tongues sliding in the grooves so that the second ring can be displaced in the direction of the second tongues.
- 20 12. An auto injector according to any of the preceding claims, further comprising a second injection lock configured in a locked state for preventing syringe movement from the first position to the second position by user operation of the injection trigger member and a release member configured for releasing the second injection lock to an unlocked state by first user operation of the release member in which unlocked state
- 25 the second injection lock does not prevent syringe movement from the first position to the second position by user operation of the injection trigger member.
13. An auto injector according to claim 12, wherein the release member is configured for abutment with the injection site during use and wherein first user operation is constituted by the user pressing the release member against the injection site.
- 30 14. An auto injector according to claim 12 or 13, wherein the second injection lock is configured in the locked state to prevent user operation of the injection trigger member.
15. An auto injector according to any of the preceding claims, further comprising a first arm configured for conveying a force from the driver to the syringe plunger end for moving the syringe from the first position to the second position.

16. An auto injector according to any of the preceding claims, further comprising a retraction lock for prevention of retraction of the syringe in a locked state.

17. An auto injector according to claim 16, wherein the release member is further configured for releasing the retraction lock to an unlocked state by second user  
5 operation of the release member thereby allowing the driver to retract the syringe.

18. An auto injector according to claim 16 or 17 further comprising a second arm configured for conveying a force from the driver to the syringe shoulder for retracting the syringe from the second position to the retracted position.

19. An auto injector according to any of claims 16 – 18, wherein the second user  
10 operation of the release member is constituted by the user removing the release member from the injection site.

1/20

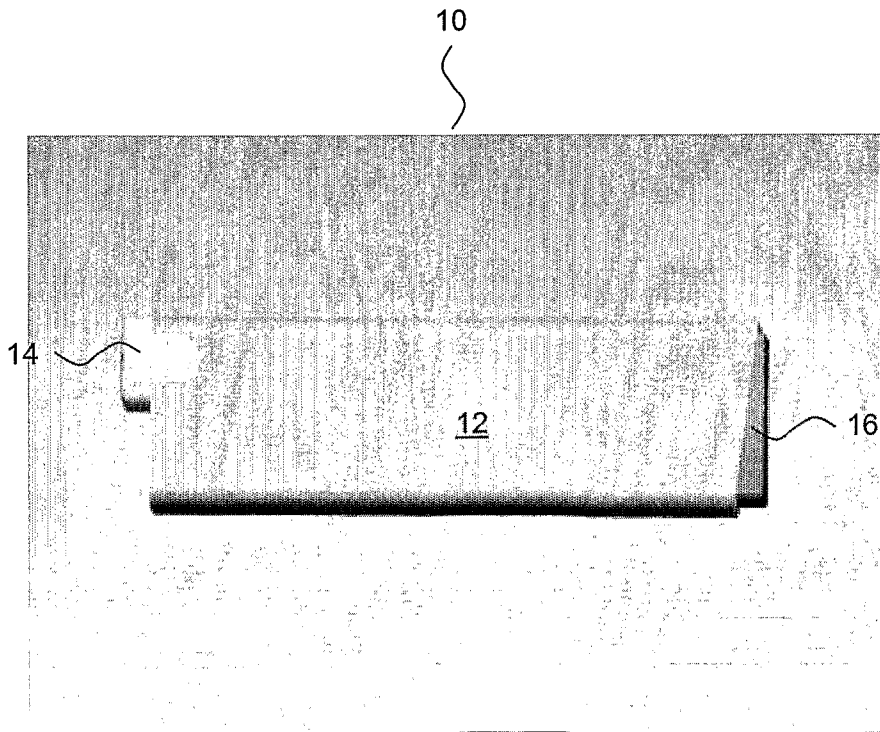
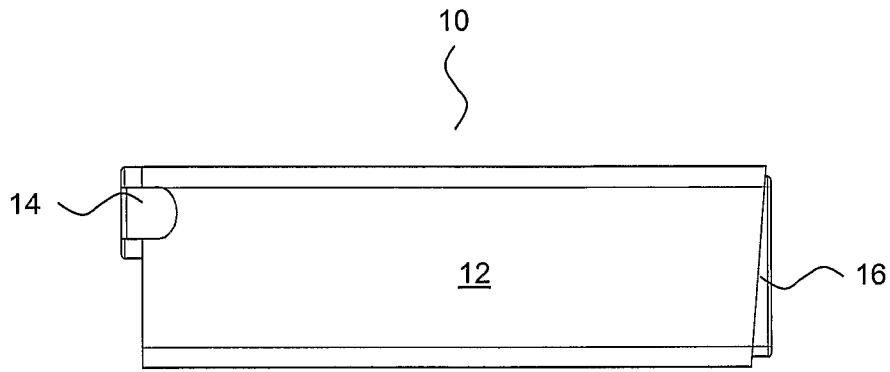

Fig. 1

2/20

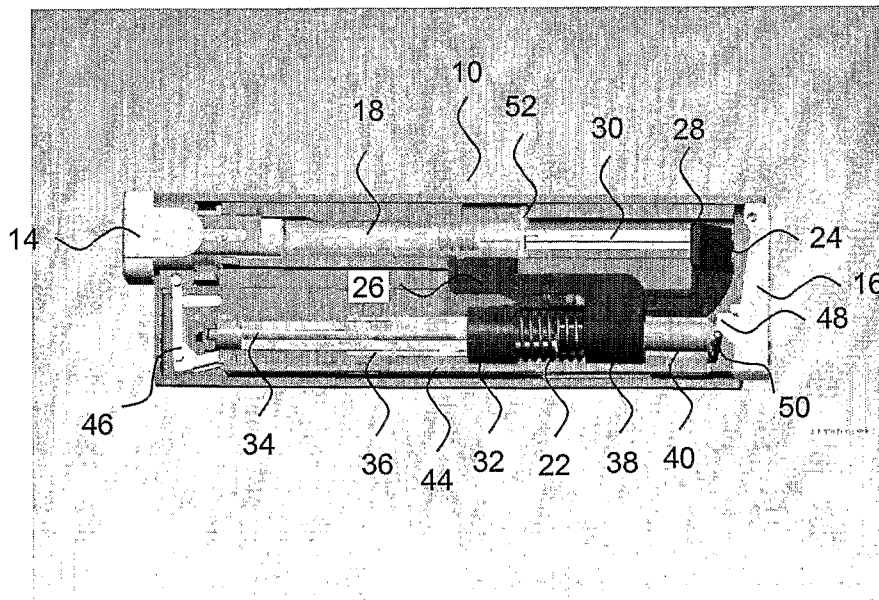
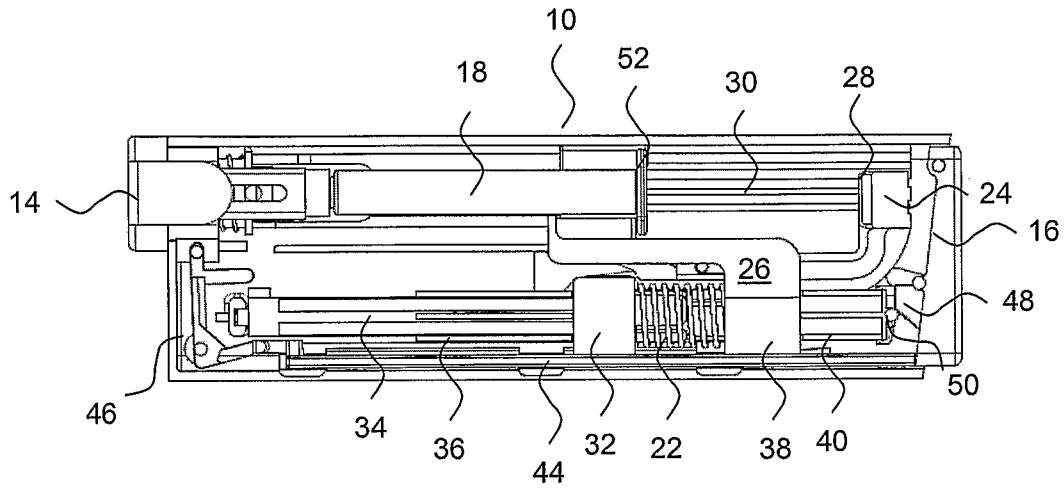

Fig. 2

3/20

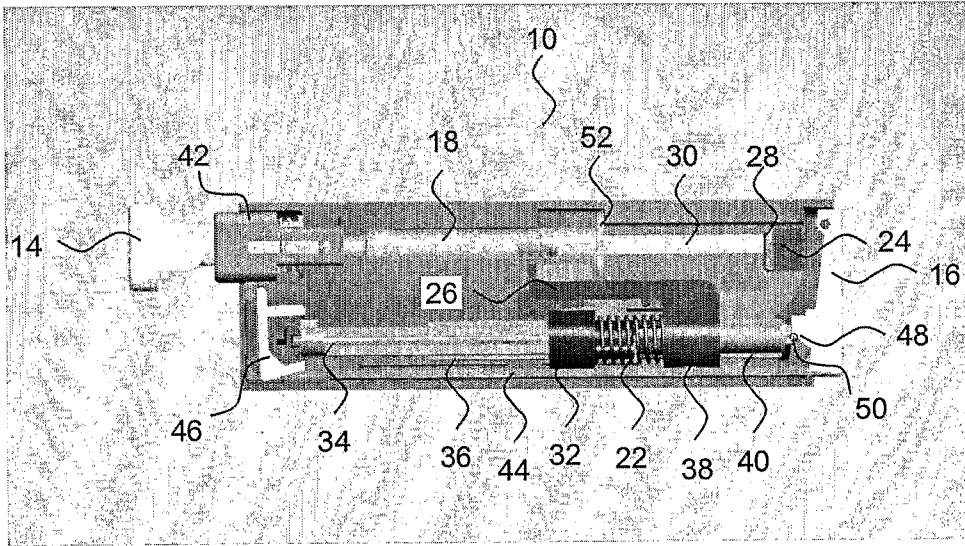

Fig. 3

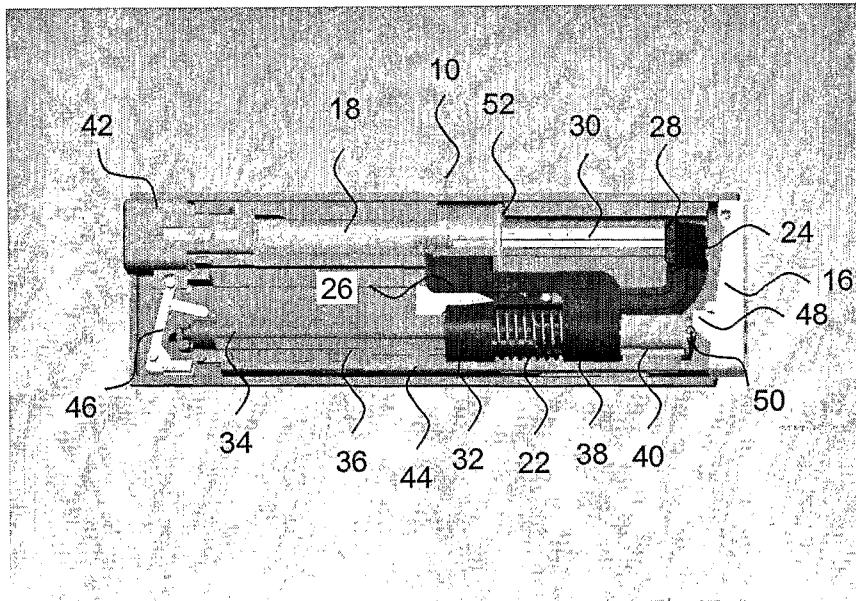

Fig. 4

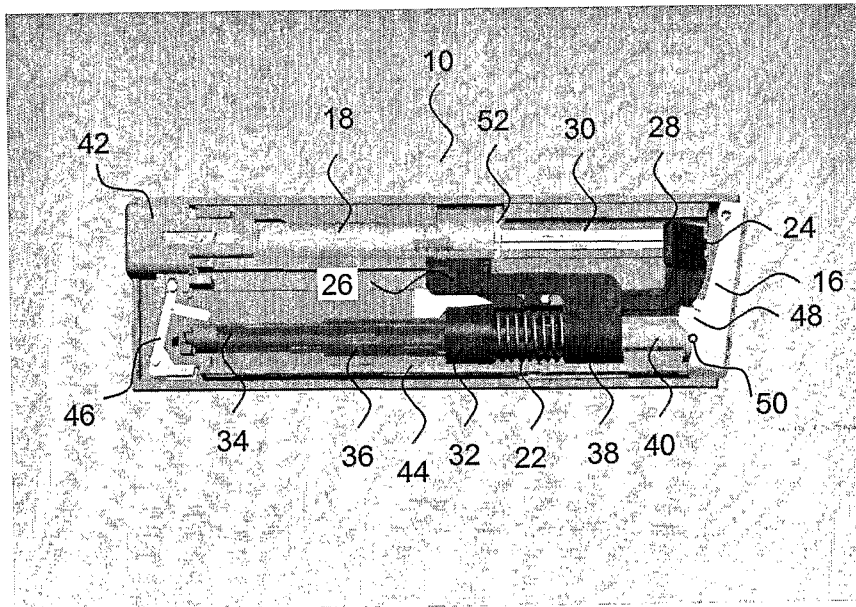

Fig. 5



7/20

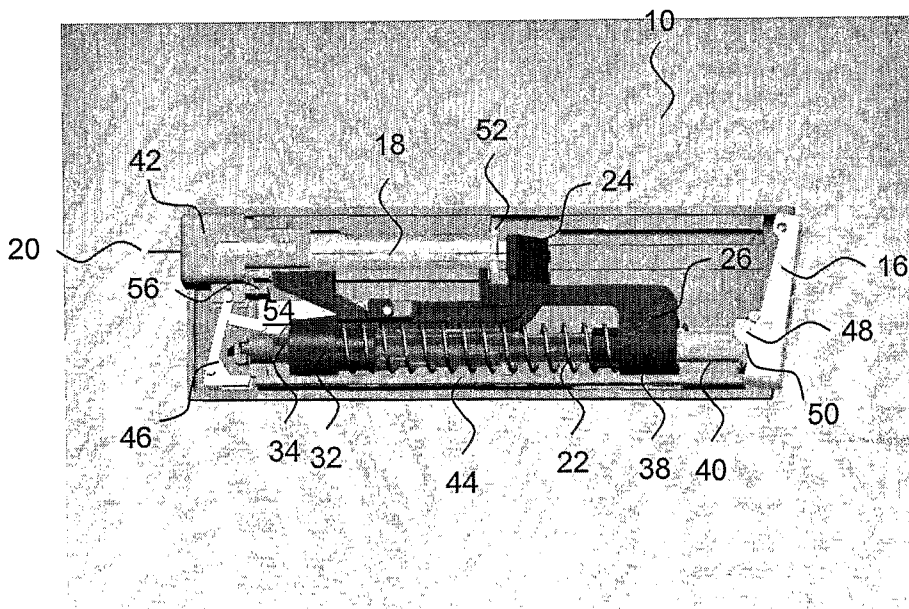

Fig. 7

8/20

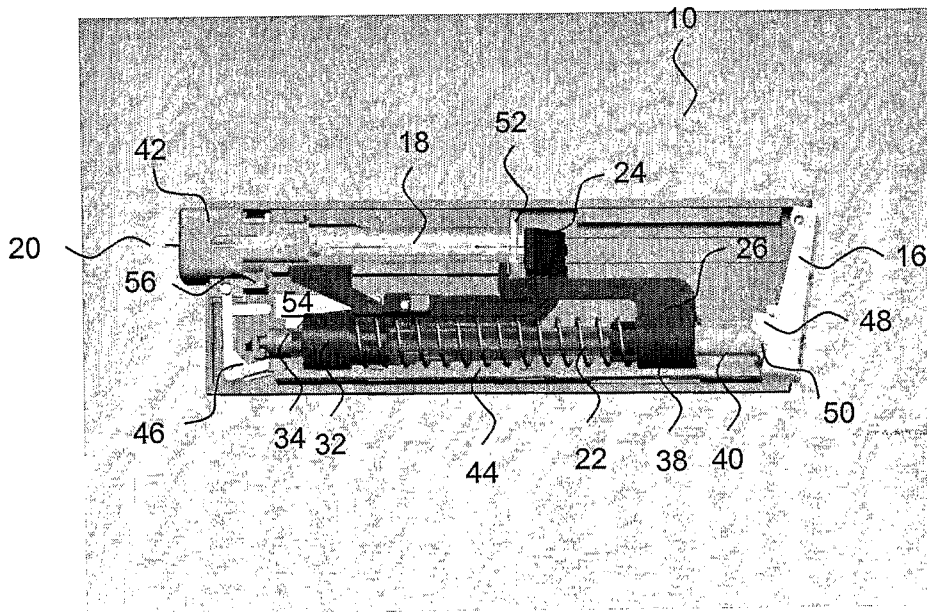

Fig. 8

9/20

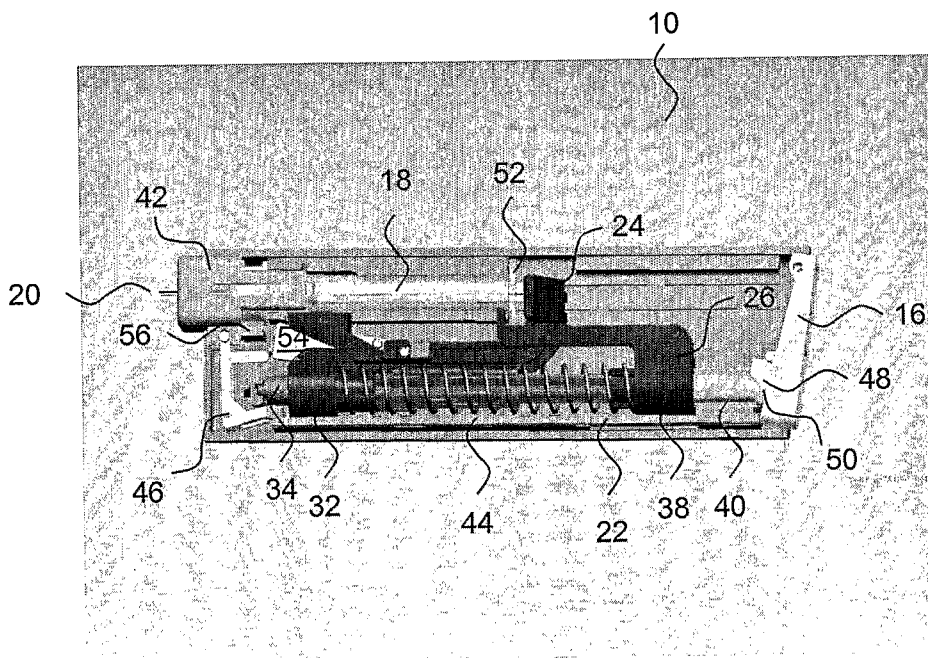

Fig. 9

10/20

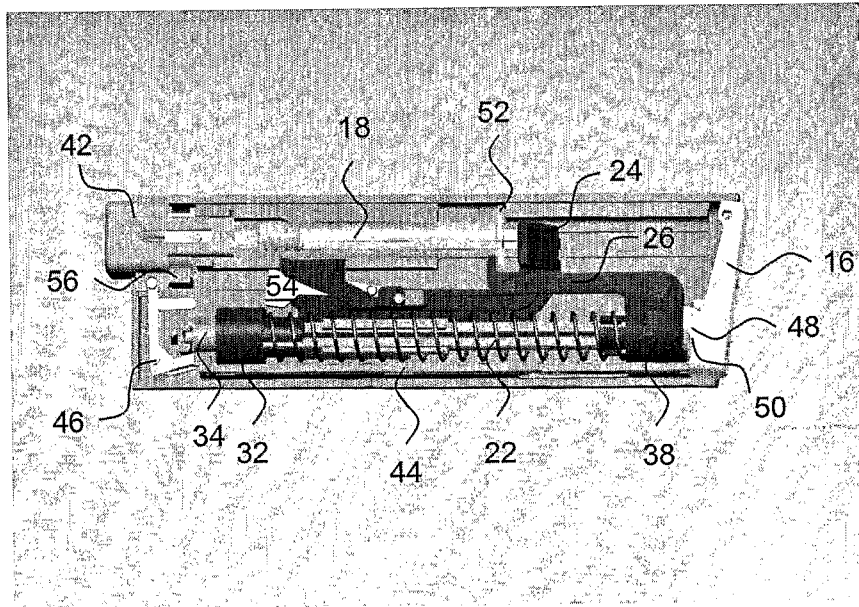

Fig. 10

11/20

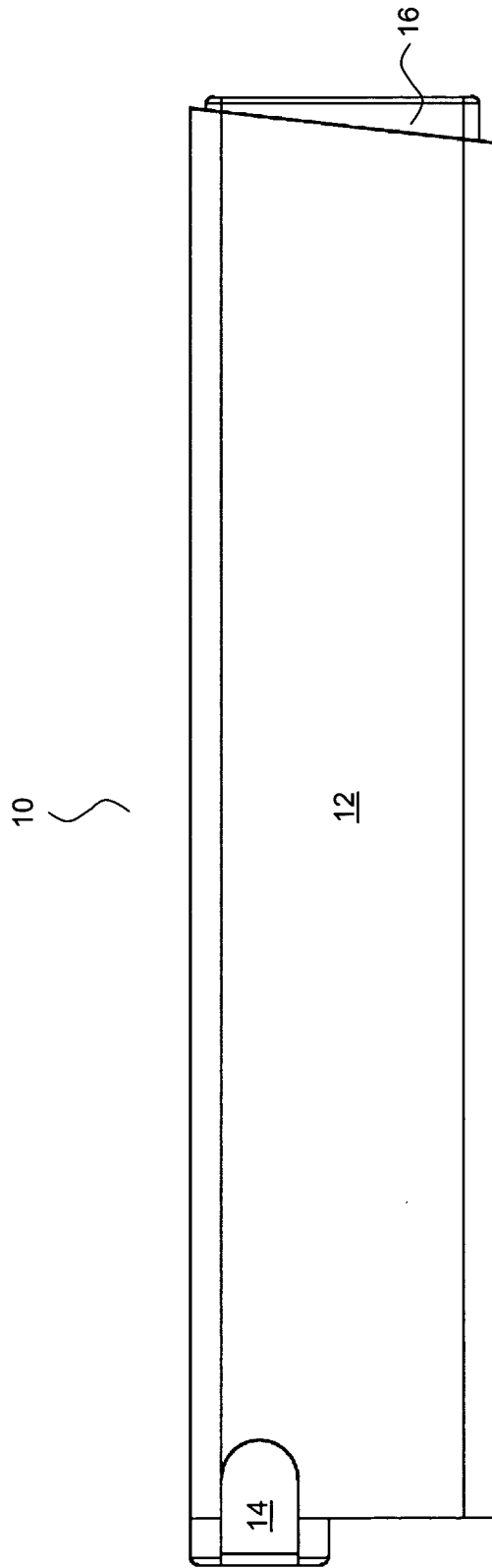

Fig. 11

12/20

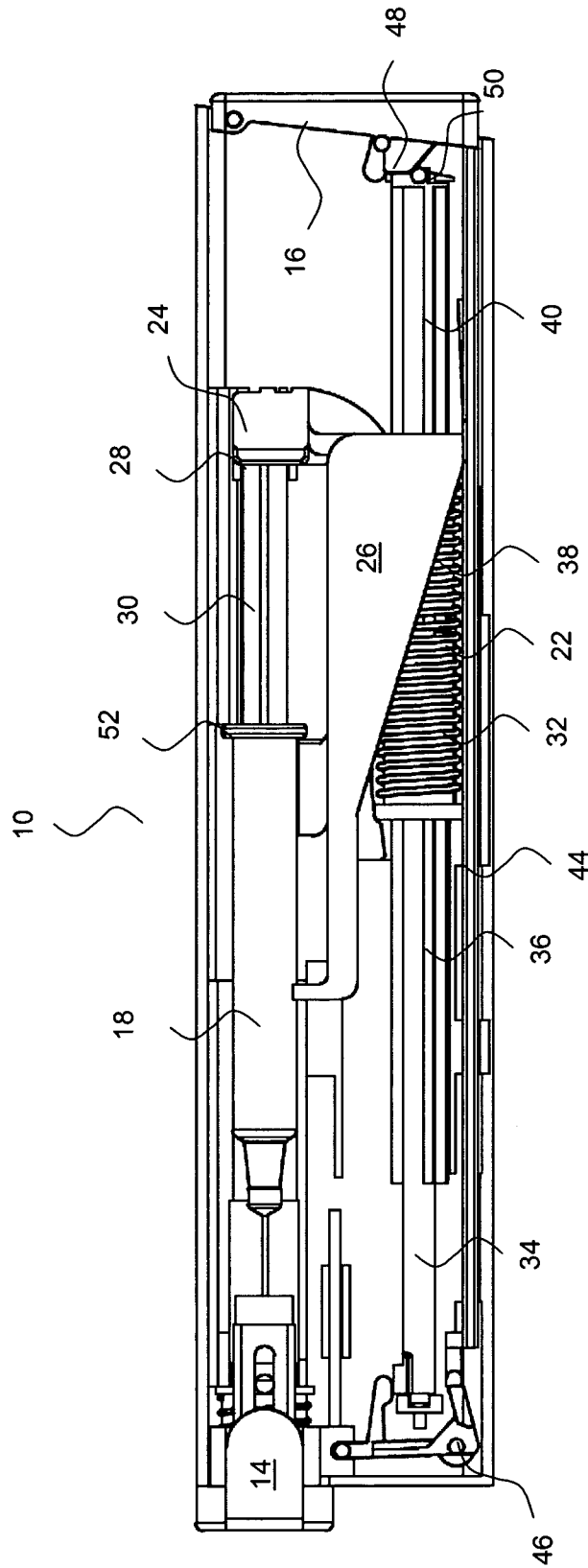

Fig. 12

13/20

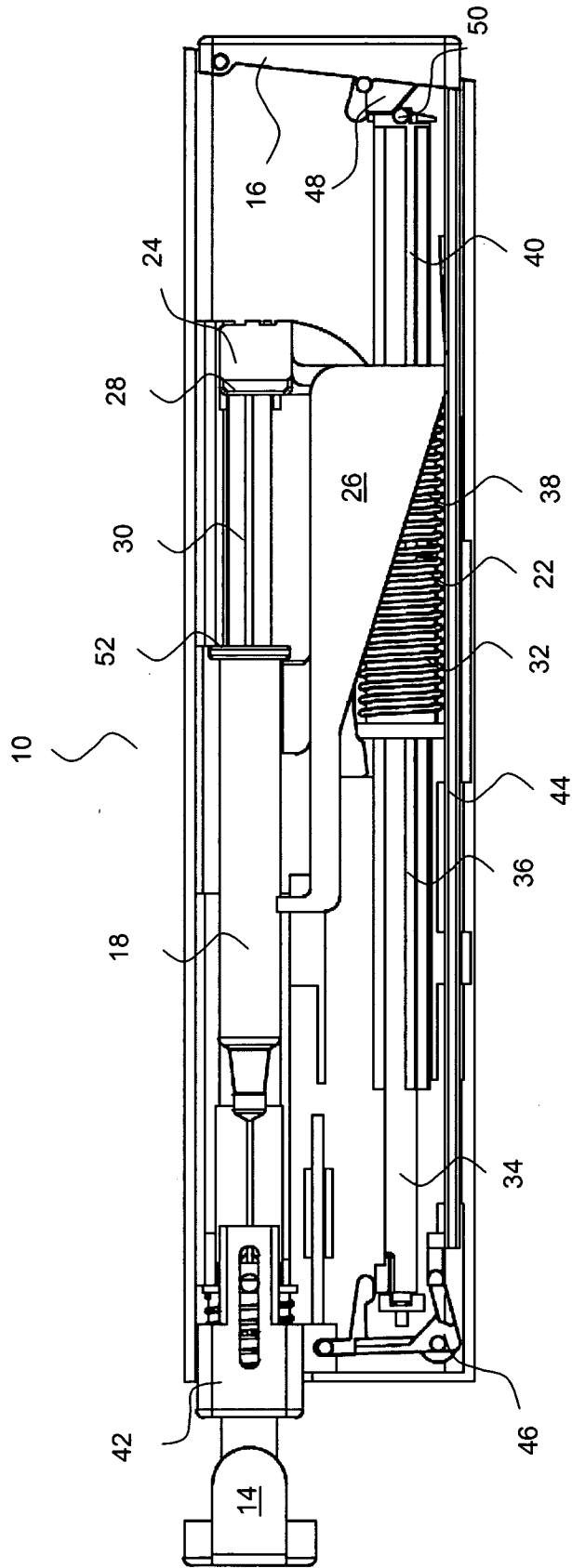

Fig. 13

14/20

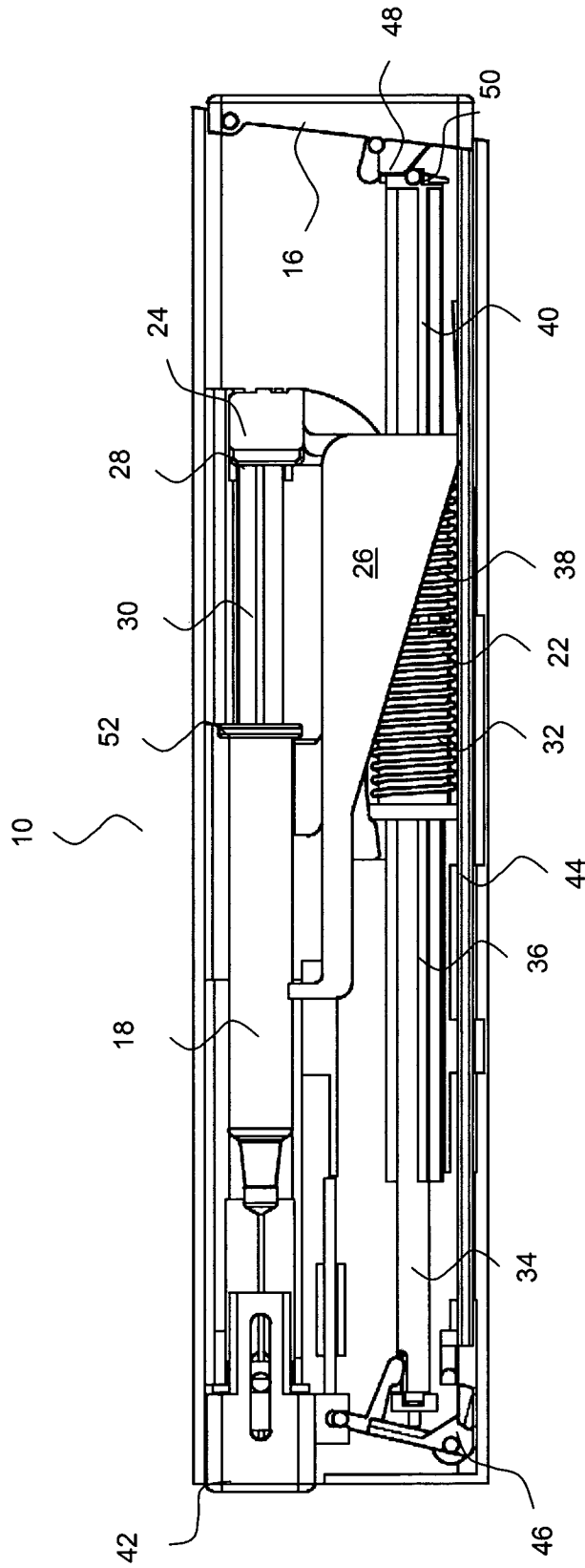

Fig. 14

15/20

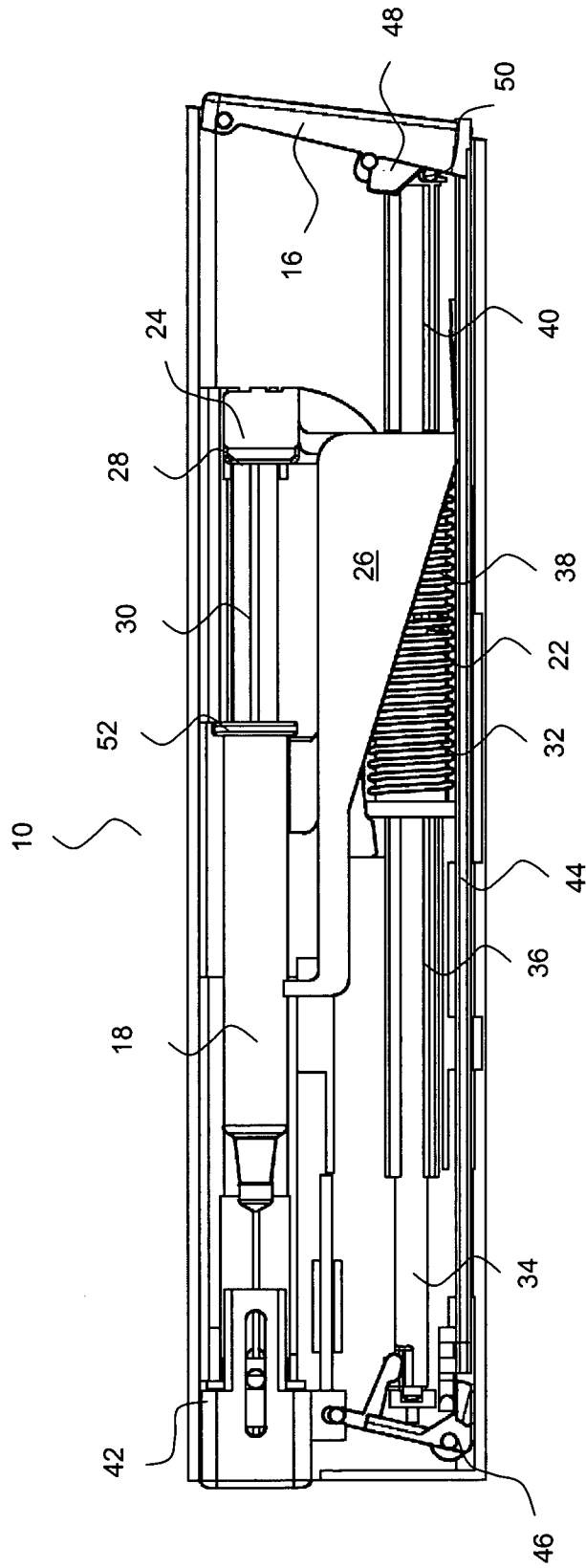

Fig. 15

16/20

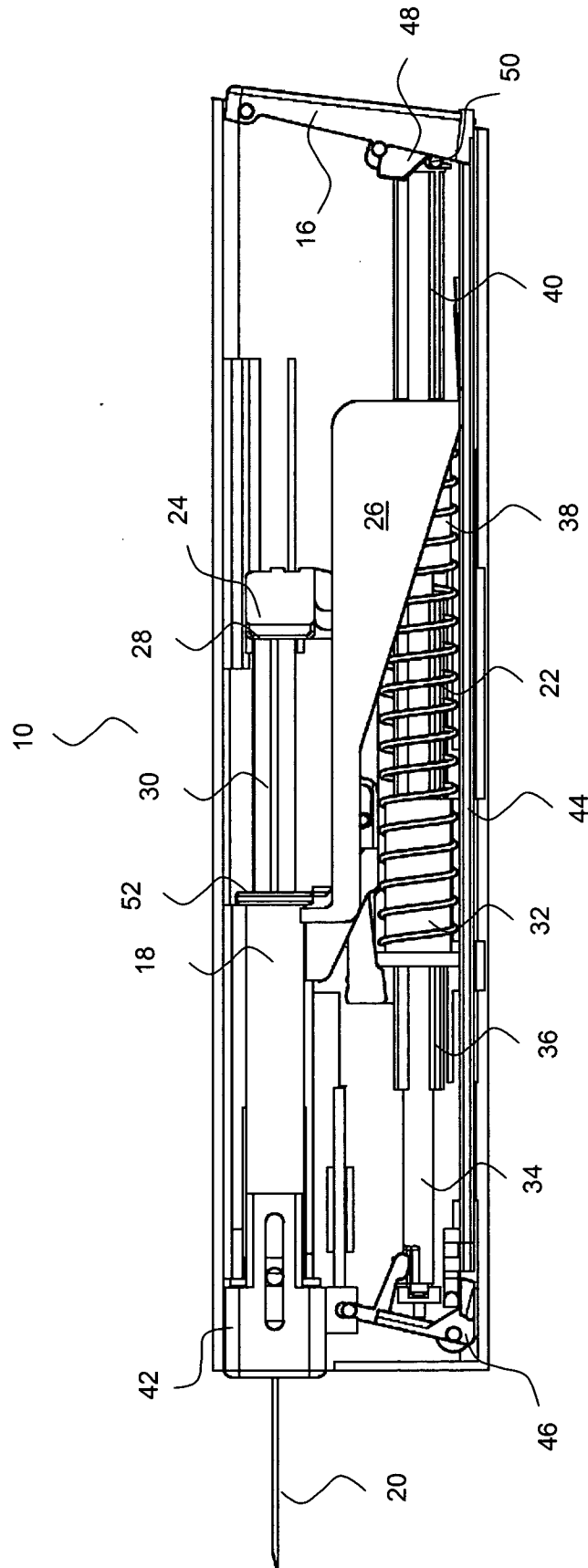

Fig. 16

17/20

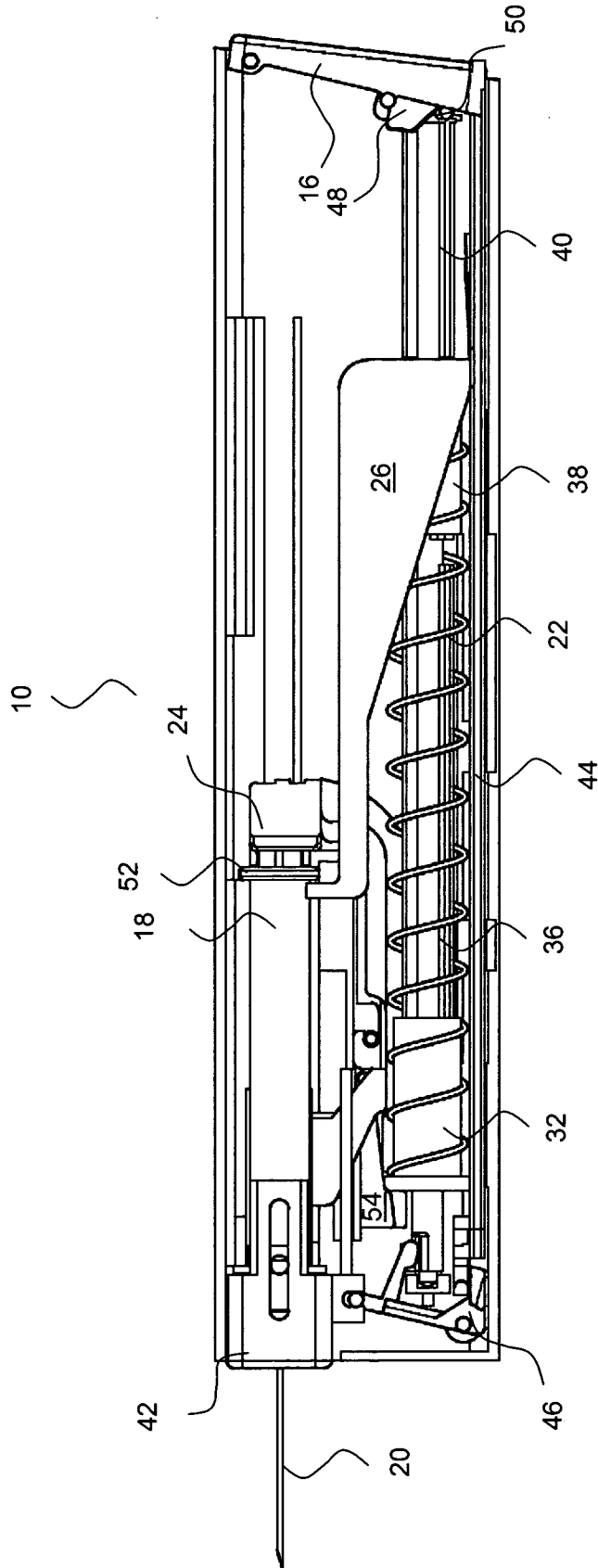

Fig. 17

18/20

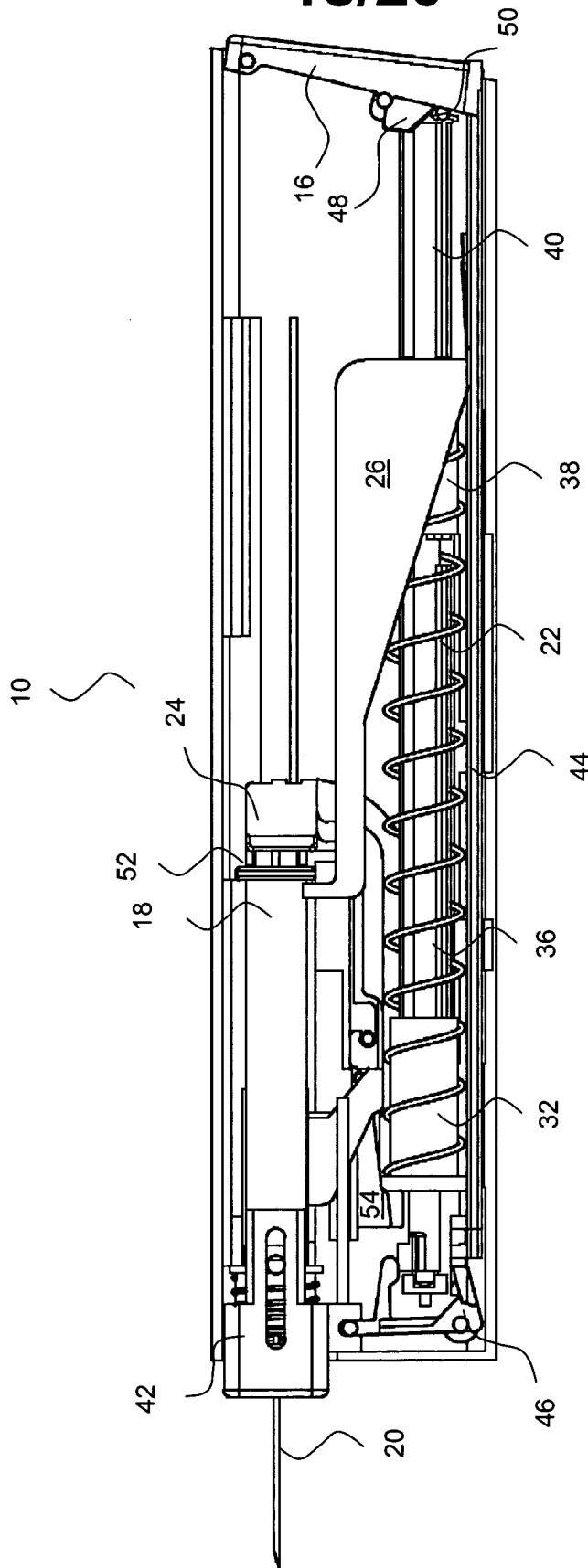
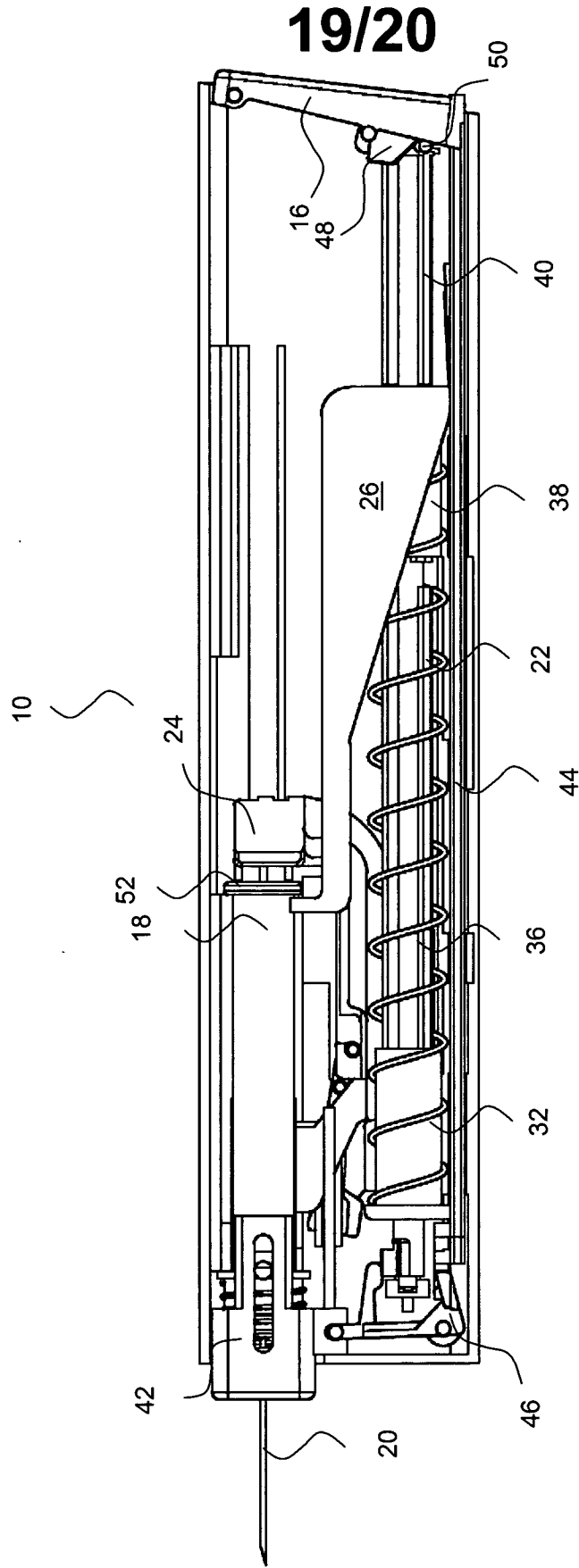

Fig. 18



**Fig. 19**

20/20

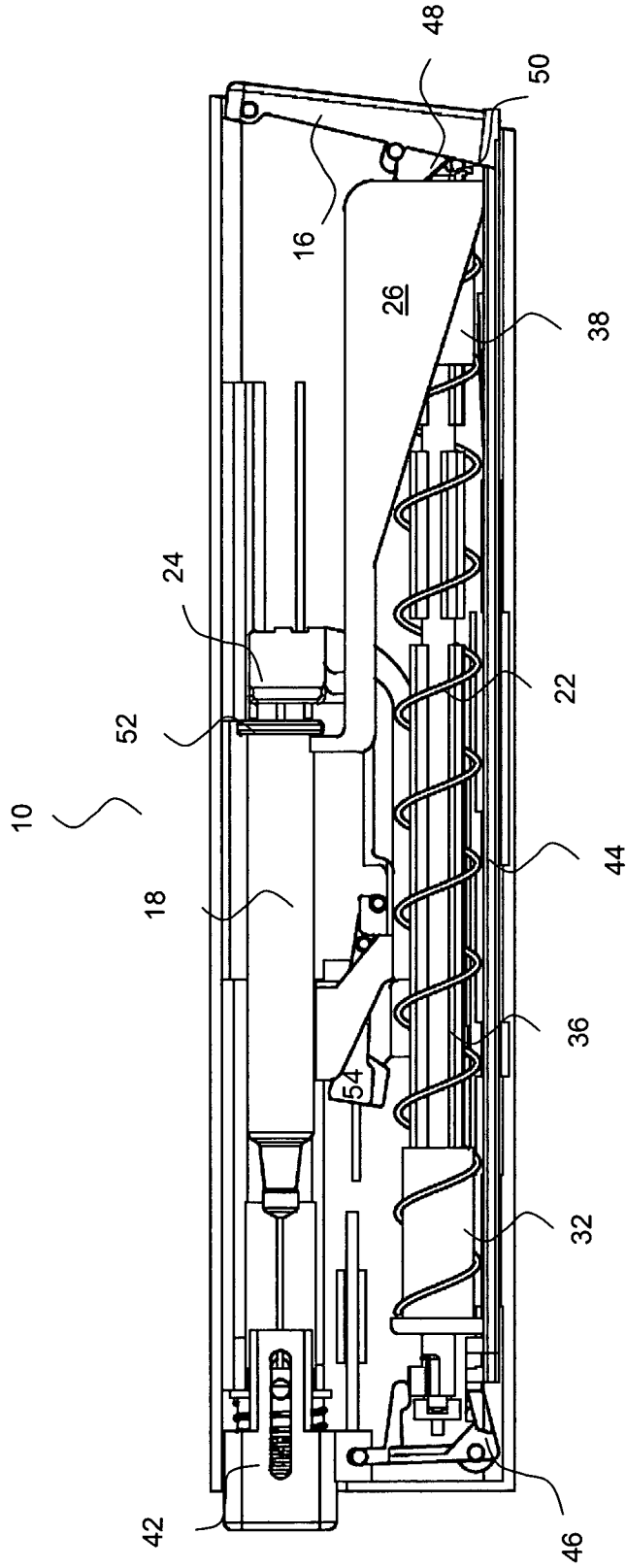

Fig. 20

**INTERNATIONAL SEARCH REPORT**

International application No  
PCT/DK2008/000399

<b>A. CLASSIFICATION OF SUBJECT MATTER</b> INV. A61M5/20		
According to International Patent Classification (IPC) or to both national classification and IPC		
<b>B. FIELDS SEARCHED</b>		
Minimum documentation searched (classification system followed by classification symbols) A61M		
Documentation searched other than minimum documentation to the extent that such documents are included in the fields searched		
Electronic data base consulted during the international search (name of data base and, where practical, search terms used) EPO-Internal, WPI Data		
<b>C. DOCUMENTS CONSIDERED TO BE RELEVANT</b>		
Category*	Citation of document, with indication, where appropriate, of the relevant passages	Relevant to claim No.
X	WO 2005/058396 A (TECPHARMA LICENSING AG [CH]; HOMMANN EDGAR [CH]) 30 June 2005 (2005-06-30)	1-11
Y	page 10, paragraph 4 - page 12, paragraph 2; figures 1-12c page 16, paragraph 2 - page 17, paragraph 2	12-19
X	WO 2007/002053 A (LILLY CO ELI [US]; BISHOP STEVEN [US]; JAMES ADRIAN BENTON [US]; LAI J) 4 January 2007 (2007-01-04) page 7, line 1 - page 9, line 21; figures 1-5	1-6
X	US 4 227 528 A (WARDLAW STEPHEN C) 14 October 1980 (1980-10-14)	2,3
Y	column 5, line 7 - column 6, line 4; figures 1-8	1,4-11
	-/--	
<input checked="" type="checkbox"/> Further documents are listed in the continuation of Box C. <input checked="" type="checkbox"/> See patent family annex.		
* Special categories of cited documents :		
*A* document defining the general state of the art which is not considered to be of particular relevance *E* earlier document but published on or after the international filing date *L* document which may throw doubts on priority claim(s) or which is cited to establish the publication date of another citation or other special reason (as specified) *O* document referring to an oral disclosure, use, exhibition or other means *P* document published prior to the international filing date but later than the priority date claimed		** later document published after the international filing date or priority date and not in conflict with the application but cited to understand the principle or theory underlying the invention *X* document of particular relevance; the claimed invention cannot be considered novel or cannot be considered to involve an inventive step when the document is taken alone *Y* document of particular relevance; the claimed invention cannot be considered to involve an inventive step when the document is combined with one or more other such documents, such combination being obvious to a person skilled in the art. *&* document member of the same patent family
Date of the actual completion of the international search  31 March 2009		Date of mailing of the international search report  08/04/2009
Name and mailing address of the ISA/ European Patent Office, P.B. 5818 Patentlaan 2 NL - 2280 HV Rijswijk Tel. (+31-70) 340-2040, Fax: (+31-70) 340-3016		Authorized officer  Björklund, Andreas

## INTERNATIONAL SEARCH REPORT

International application No  
PCT/DK2008/000399

C(Continuation). DOCUMENTS CONSIDERED TO BE RELEVANT		
Category*	Citation of document, with indication, where appropriate, of the relevant passages	Relevant to claim No.
Y	DE 20 2005 014958 U1 (HOELZLE DIETER TECH PROJEKTE [DE]) 8 December 2005 (2005-12-08)	1,4-11
A	paragraphs [0043] - [0048]; figures 1A-6B -----	12-19
Y	US 6 575 939 B1 (BRUNEL MARC [FR]) 10 June 2003 (2003-06-10) column 8, line 40 - column 9, line 39; figures 1-16 -----	12-19
A	WO 2004/054644 A (SAFE T LTD [GB]; JEFFREY PETER [GB]) 1 July 2004 (2004-07-01) figures 1-8C -----	1-11
A	WO 2007/099044 A (SHL MEDICAL AB [SE]; WIKNER JAKOB [SE]; BRUNNBERG LENNART [SE]) 7 September 2007 (2007-09-07) paragraphs [0049] - [0051]; figures 1-8 -----	1-11
A	WO 02/17996 A (NOVO NORDISK AS [DK]) 7 March 2002 (2002-03-07) page 5, line 32 - page 7, line 27; figures 1,2 -----	1-11
P,X	WO 2007/129324 A (YIGAL GIL [IL]) 15 November 2007 (2007-11-15) paragraphs [0061] - [0067], [0070]; figures 1a-21 -----	1-3,5,6, 8,9

## INTERNATIONAL SEARCH REPORT

International application No

PCT/DK2008/000399

Patent document cited in search report	Publication date	Patent family member(s)	Publication date
WO 2005058396 A	30-06-2005	AU 2004298302 A1 EP 1703929 A1 JP 2007514487 T US 2007027430 A1	30-06-2005 27-09-2006 07-06-2007 01-02-2007
WO 2007002053 A	04-01-2007	CN 101282756 A EP 1904130 A2	08-10-2008 02-04-2008
US 4227528 A	14-10-1980	NONE	
DE 202005014958 U1	08-12-2005	CA 2623152 A1 CN 101267856 A WO 2007033638 A1 DE 112006003252 A5 EP 1931405 A1 KR 20080065592 A US 2008188798 A1	29-03-2007 17-09-2008 29-03-2007 04-09-2008 18-06-2008 14-07-2008 07-08-2008
US 6575939 B1	10-06-2003	AT 227593 T AU 1767999 A DE 69809471 D1 DE 69809471 T2 EP 1053037 A1 ES 2188036 T3 FR 2774294 A1 WO 9939759 A1	15-11-2002 23-08-1999 19-12-2002 02-10-2003 22-11-2000 16-06-2003 06-08-1999 12-08-1999
WO 2004054644 A	01-07-2004	AU 2003292410 A1 CA 2508426 A1 EP 1581289 A1 JP 2006509568 T US 2005288633 A1	09-07-2004 01-07-2004 05-10-2005 23-03-2006 29-12-2005
WO 2007099044 A	07-09-2007	EP 1991294 A1 US 2009005735 A1	19-11-2008 01-01-2009
WO 0217996 A	07-03-2002	AU 8175301 A US 2002095120 A1	13-03-2002 18-07-2002
WO 2007129324 A	15-11-2007	NONE	