

(19) World Intellectual Property
Organization
International Bureau



(43) International Publication Date
22 July 2004 (22.07.2004)

PCT

(10) International Publication Number
WO 2004/061501 A1

(51) International Patent Classification⁷: **G02B 6/32**, 6/25

John; 162 East Vargo Road, Horseheads, NY 14845 (US). **SHASHIDHAR, Nagaraja**; 3444 Fieldstone Lane, Painted Post, NY 14870 (US).

(21) International Application Number:
PCT/US2003/039641

(74) Agent: **SCHAEBERLE, Timothy, M.**; Corning Incorporated, SP TI 3 1, Corning, NY 14831 (US).

(22) International Filing Date:
12 December 2003 (12.12.2003)

(81) Designated States (*national*): CN, JP, KR.

(25) Filing Language: English

(84) Designated States (*regional*): European patent (AT, BE, BG, CH, CY, CZ, DE, DK, EE, ES, FI, FR, GB, GR, HU, IE, IT, LU, MC, NL, PT, RO, SE, SI, SK, TR).

(26) Publication Language: English

(30) Priority Data:
60/437,328 31 December 2002 (31.12.2002) US
10/699,450 31 October 2003 (31.10.2003) US

Published:

- with international search report
- before the expiration of the time limit for amending the claims and to be republished in the event of receipt of amendments

(71) Applicant: **CORNING INCORPORATED** [US/US]; 1 Riverfront Plaza, Corning, NY 14831 (US).

For two-letter codes and other abbreviations, refer to the "Guidance Notes on Codes and Abbreviations" appearing at the beginning of each regular issue of the PCT Gazette.

(72) Inventors: **BHAGAVATULA, Venkata, A.**; 29 Orchard Drive, Big Flats, NY 14814 (US). **HIMMELREICH,**

(54) Title: OPTICAL FIBER LENS AND METHOD OF MANUFACTURE

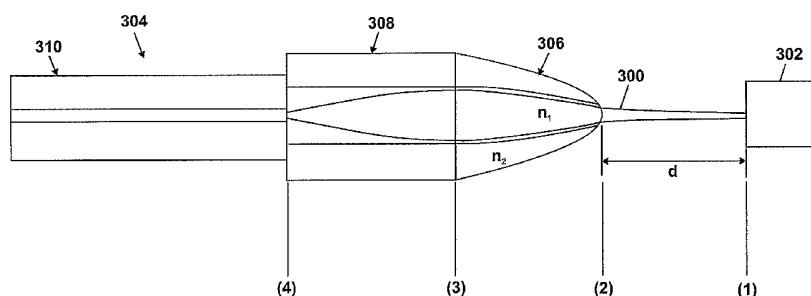

(57) Abstract: A fiber lens includes a graded-index lens (308), a single-mode fiber (310) disposed at a first end of the graded-index lens (308), and a refractive lens (306) having a hyperbolic or near-hyperbolic shape disposed at a second end of the graded-index lens (308) to focus a beam from the single-mode fiber (310) to a diffraction-limited spot.

WO 2004/061501 A1

OPTICAL FIBER LENS AND METHOD OF MANUFACTURE

Cross-Reference to Related Applications

[0001] This application claims the benefit of U.S. Provisional Application Serial No. 60/437,328, filed December 31, 2002, entitled "Small Mode-Field Fiber Lens." And U.S. Patent Application 10/699,450, filed October 31, 2003, entitled "Small Mode-Field Fiber Lens".

Background of the Invention

[0002] The invention relates generally to optical devices for coupling optical signals between optical components. More specifically, the invention relates to a fiber lens for coupling signals between optical components.

[0003] Various approaches are used in optical communications to couple optical signals between optical components, such as optical fibers, laser diodes, and semiconductor optical amplifiers. One approach involves the use of a fiber lens, which is a monolithic device having a lens disposed at one end of a pigtail fiber. Light can enter or exit the fiber lens through either the lens or the pigtail fiber. The fiber lens can focus light from the pigtail fiber into a spot having the required size and intensity at a selected working distance. However, prior art has limitations on how small the spot size can be to achieve the required intensity distribution and limitations on the working distance achievable while controlling the spot size and intensity distribution. For some applications, it is desirable to obtain mode field diameters as small as 2.5 to 3.0 μm while maintaining Gaussian intensity distribution at working distances larger than 5 μm . Examples of such applications include coupling of optical signals from a semiconductor optical amplifier to an optical fiber, from a high-index semiconductor or dielectric waveguide to an optical fiber, etc.

[0004] From the foregoing, there is desired a fiber lens that can produce a focused spot with a small mode field diameter and the required intensity distribution for a broad range of working distances.

Summary of the Invention

[0005] In one aspect, the invention relates to a fiber lens which comprises a graded-index lens, a single-mode fiber disposed at a first end of the graded-index lens, and a refractive lens having a hyperbolic or near-hyperbolic shape disposed at a second end of the graded-index lens to focus a beam from the single-mode fiber to a diffraction-limited spot.

[0006] In another aspect, the invention relates to a fiber lens which comprises a single-mode fiber and a lens disposed at an end of the single-mode fiber, wherein a mode field diameter at a beam waist of a beam emerging from a tip of the lens is less than 10 μm and a ratio of distance from the tip of the lens to the beam waist to the mode field diameter at the beam waist is greater than 5.

[0007] In yet another aspect, the invention relates to a method of making a fiber lens which comprises splicing a single-mode fiber to a graded-index fiber, cutting the graded-index fiber to a desired length, and rounding a tip of the graded-index fiber into a hyperbolic or near-hyperbolic shape.

[0008] In another aspect, the invention relates to a method of making a fiber lens which comprises splicing a single-mode fiber to a graded-index fiber, cutting the graded-index fiber to a desired length, splicing a coreless fiber to the graded-index fiber, cutting the coreless fiber to a desired length, and rounding a tip of the coreless fiber into a hyperbolic or near-hyperbolic shape.

[0009] These and other features and advantages of the invention will be discussed in more detail in the following detailed description of the invention and in conjunction with the following figures.

Brief Description of the Drawings

[0010] The invention is illustrated by way of example, and not by way of limitation, in the figures accompanying the drawings, and in which like reference numerals refer to similar elements, and in which:

[0011] Figure 1A is a schematic of a fiber lens according to an embodiment of the invention.

[0012] Figure 1B is a geometrical representation of a hyperbolic lens.

[0013] Figure 1C shows a fiber lens having a coreless spacer rod interposed between a GRIN lens and a refractive lens.

[0014] Figure 2A is a plot of radius of curvature at the tip of a hyperbolic lens as a function of working distance for a case where a hyperbolic lens is disposed at an end of a single-mode pigtail fiber.

[0015] Figure 2B shows variation of MFD at the tip of the hyperbolic lens as a function of working distance for the example shown in Figure 2A.

[0016] Figure 3 is a schematic of beam propagation through a fiber lens of the present invention.

[0017] Figure 4A is a geometrical representation of a planar beam wavefront and a diverging beam wavefront.

[0018] Figure 4B is a schematic of changes to be made to a hyperbolic shape to form a near-hyperbolic lens.

[0019] Figure 5 is a plot of far-field intensity distribution as a function of far-field divergence angle for a fiber lens according to an embodiment of the invention.

Detailed Description of the Preferred Embodiments

[0020] The invention will now be described in detail with reference to a few preferred embodiments, as illustrated in the accompanying drawings. In the following description, numerous specific details are set forth in order to provide a thorough understanding of the invention. It will be apparent, however, to one of ordinary skill in the art that the invention may be practiced without some or all of these specific details. In other instances, well-known process steps and/or features have not been described in detail to avoid unnecessarily obscuring the invention. The features and advantages of the invention may be better understood with reference to the drawings and the following discussions.

[0021] Embodiments of the invention provide a fiber lens that can focus light from an optical fiber into a spot having the required size and intensity distribution at a distance required by the application. The fiber lens uses a combination of a refractive lens and a graded-index (GRIN) lens to produce a focused beam. In one embodiment, the refractive lens has a hyperbolic shape for focusing a collimated beam into a diffraction-limited spot. In another embodiment, the refractive lens has a near-hyperbolic shape for focusing a non-collimated beam into a diffraction-limited spot. With control of the multimode parameters of the GRIN lens and the shape of the refractive lens, small mode field diameters (MFDs), e.g., in a range from 2 to 5 μm , with reasonably Gaussian intensity distributions, have been achieved. Further, long working distances as large as 25 to 40 μm have been achieved at 1550 nm operating wavelength while maintaining the small MFDs and Gaussian intensity distributions.

[0022] Figure 1A shows a fiber lens **100** according to an embodiment of the invention. The fiber lens **100** includes a graded-index (GRIN) lens **102**, a refractive lens **104** disposed at one end of the GRIN lens **102**, and a single-mode pigtail fiber **106** disposed at another end of the GRIN-fiber lens **102**. The GRIN lens **102** has a core **108**, which may or may not be bounded by a cladding **110**. The core **108** of the GRIN lens **102** preferably has a refractive index profile that increases radially toward the optical axis of the fiber lens **100**, such as a square law or parabolic profile. In one embodiment, the refractive lens **104** is a

hyperbolic lens having a hyperbolic surface **112**. The hyperbolic lens **104** has a core **114**, which may or may not be bounded by a cladding **116**. Ideally, the core **114** should have a uniform refractive index, but it may be easier to form the refractive lens **104** by polishing an end of the GRIN lens **102** into the hyperbolic surface **112**, in which case the core **114** would have a refractive index profile that increases radially toward the optical axis of the fiber lens **100**.

[0023] The profile of the hyperbolic lens **104** is given by:

$$\frac{u^2}{a^2} - \frac{v^2}{b^2} = 1 \quad (1a)$$

Figure 1B is a graphical representation of the expression above. In this representation, the hyperbolic lens **104** is a branch of a hyperbola on a u-v coordinate system, and the vertex of the hyperbola branch lies on the u-axis at (a,0). The focus of the hyperbola branch is at (c, 0), where c is given by:

$$c = \sqrt{a^2 + b^2} \quad (1b)$$

The hyperbola branch is contained within two asymptotes, which are represented by:

$$bu \pm av = 0 \quad (1c)$$

The slopes of the asymptotes are +b/a and -b/a. The asymptotes intersect at the origin (0,0) to form a wedge having an apex angle, α , which is given by:

$$\alpha = 2 \tan^{-1}(b/a) \quad (1d)$$

[0024] According to Edwards et al., for an ideal hyperbolic profile that exactly transforms an incident spherical wave into a plane wave, the terms a and b in equations (1a) through (1d) above are given by the following expressions:

$$a^2 = \left(\frac{n_2}{n_1 + n_2} \right)^2 r_2^2 \quad (2a)$$

$$b^2 = \left(\frac{n_1 - n_2}{n_1 + n_2} \right)^2 r_2^2 \quad (2b)$$

where n_1 is the refractive index of the core of the hyperbolic lens, n_2 is the refractive index of the medium surrounding the core of the hyperbolic lens, and r_2 is the radius of curvature at the tip of the hyperbolic lens. (Edwards, Christopher A., Presby, Herman M., and Dragone, Corrado. "Ideal Microlenses for Laser to Fiber Coupling." *Journal of Lightwave Technology*, Vol 11, No. 2, (1993): 252.) With this hyperbolic profile, the mode field radii at planes (1) and (2), shown in Figure 1B, are equal, and the radius of curvature at plane (2) is infinity, i.e., the beam wavefront at plane (2) is planar.

[0025] Returning to Figure 1A, the pigtail fiber 106 could be any standard single-mode fiber, such as Corning SMF-28[®] fiber, or a specialty single-mode fiber, such as a polarization-maintaining (PM) fiber. The pigtail fiber 106 may be circularly symmetrical when viewed from the end or may have other shape, e.g., square or elliptical. The GRIN lens 102 is preferably affixed to the pigtail fiber 106. For reliability and long-term stability, the GRIN lens 102 could be affixed to the pigtail fiber 106 by fusion splicing. The hyperbolic lens 104 could be formed directly on the GRIN lens 102 or formed on a coreless spacer rod attached to the GRIN lens 102. As shown in Figure 1C, the hyperbolic lens 104 could also be attached to a coreless spacer rod 120, which is attached to the GRIN lens 102. Since final dimensions of the refractive lenses and spacer rods are generally quite small, in the preferred approach, longer lengths of the grin fiber or spacer rod are attached to the pigtail first and cut or cleaved to required length before the refractive lens is shaped on the end (A coreless spacer rod could also be interposed between the GRIN lens 102 and the pigtail fiber 106.) The hyperbolic lens 104 can be formed by shaping a length of fiber into a cone/wedge having an apex angle (α in Figure 1B). For example, the fiber could be shaped into a cone/wedge using a taper-cutting process (for symmetry) or laser micromachining with polishing. A curvature can then be formed at the tip of the resulting cone/wedge to give the desired

hyperbolic profile. Although not shown in the drawings, the GRIN lens and/or the single-mode pigtail fiber could be tapered. The overall diameter of the pigtail fiber could be smaller than or substantially the same as the overall diameter of the GRIN lens.

[0026] The GRIN lens **102** and the hyperbolic lens **104** produce a focused beam having a small mode field diameter (MFD), good wavefront characteristics, and long working distances. In one embodiment, the following attributes are desirable: mode field diameter (MFD) at the beam waist less than 10 μm , preferably in a range from 2 to 5 μm , with reasonably Gaussian intensity distributions, working distances larger than 5 μm , preferably in a range from 20 to 60 μm , ratio of distance from tip of the lens to the beam waist to the MFD at the beam waist greater than 5, and lens-to-lens coupling efficiency greater than 65% for operating wavelengths in a range from 250 to 2,000 nm. Both the hyperbolic lens **104** and the GRIN lens **102** are important to achieving the small MFDs and long working distances. For instance, if the GRIN lens **102** is not used, the spot size at the tip of the hyperbolic lens **104** would be limited to the MFD of the single-mode pigtail fiber **106**, which would limit the working distance achievable to small values. For example, most practical single-mode fibers have a MFD in a range of 10-12 μm at 1550 nm operating wavelength. For a single-mode fiber having 10- μm MFD and 38- μm divergence angle, which are needed for a focused MFD of 3 μm , the longest working distance would be limited to about 14 μm if only a hyperbolic lens is used.

[0027] To further illustrate the importance of using both the hyperbolic lens **104** and the GRIN lens **102**, consider Figure 2A which shows radius of curvature at the tip of a hyperbolic lens as a function of working distance for a fiber lens having a hyperbolic lens disposed at an end of a single-mode pigtail fiber without intervention of a GRIN lens. The figure shows that this fiber lens has good wavefront characteristics. Figure 2B shows variation of MFD at the tip of the hyperbolic lens as a function of working distance for the example shown in Figure 2A. This figure shows that for focused MFDs ranging from 2.0-3.5 μm , the MFD at the tip of the hyperbolic lens must be greater than 10 μm to achieve working distances greater than 20 μm . Unless a GRIN lens is interposed between the hyperbolic lens

and the single-mode pigtail fiber, working distances much greater than 20 μm would not be achievable using most practical single-mode fibers because the MFD at the tip of the hyperbolic lens would be limited to the MFD of the single-mode pigtail fiber.

[0028] Figure 3 shows a beam **300** propagating through planes **(1)**, **(2)**, **(3)**, and **(4)**. Plane **(1)** contains an end face of an optical device **302**. Plane **(2)** coincides with the tip of a fiber lens **304**. Plane **(3)** coincides with an interface between a hyperbolic lens **306** and a GRIN lens **308**. Plane **(4)** contains an end face of a single-mode pigtail fiber **310**. Assume that the optical device **302** has MFD equal to $2w_0$ and is positioned a distance d from the tip of the fiber lens **304**. In this case, it is desirable to design the fiber lens **304** such that the focused spot size of the fiber lens **304** is as close as possible to $2w_0$ at the distance d from the tip of the fiber lens **304** at an operating wavelength λ . The properties of the beam at the end of the GRIN lens **308** and the properties of the hyperbolic lens **306** determine the spot size characteristics of the focused beam. In one embodiment, a process for designing the fiber lens **304** includes (1) calculating the radius of curvature and mode field needed at the tip of the fiber lens **304** to produce the focused spot size, (2) determining the profile of the hyperbolic lens **306** using the calculated radius of curvature, and (3) determining the parameters of the GRIN lens **308** using the calculated mode field and the mode field of the pigtail fiber **310**. The following is a discussion of one possible way of implementing this process.

[0029] For step (1), the mode field radius (w_2) and the radius of curvature (r_2) at plane **(2)**, i.e., at the tip of the fiber lens **304**, may be determined using well-known formula for the propagation of Gaussian beams. For example, Edwards et al., supra, give the following expressions for w_2 and r_2 :

$$w_2 = w_0 \sqrt{1 + \left(\frac{\lambda d}{\pi w_0^2} \right)^2} \quad (2a)$$

$$r_2 = \left(\frac{\pi}{\lambda}\right)^2 \frac{(w_0 w_2)^2}{d} \quad (2b)$$

For step (2), the radius of curvature (r_2) obtained from equations (2a) and (2b) together with equations (1a) – (1d) can be used to determine the profile of the hyperbolic lens **306**.

[0030] For step (3), the GRIN lens **308** transforms a beam at plane **(3)**, with mode field radius w_3 and radius of curvature r_3 , to a beam at plane **(4)**, with mode field radius w_4 and radius of curvature r_4 . For optimum design, w_4 needs to be as close as possible to the mode field radius w_p of the single-mode pigtail fiber **310**. One approach to achieving this optimum design would be to select a specialty single-mode pigtail fiber such that w_p equal to w_4 for a readily-available GRIN lens **308**. Alternately, the parameters of the GRIN lens **308** could be chosen such that w_4 is as close as possible to a specific value of w_p . In this case, standard single-mode fibers, such as Corning SMF-28[®] fiber, can be used as pigtail fibers. The GRIN lens parameters include the core diameter, outside (or cladding) diameter, index profile, relative index difference between the core and cladding, and the length of the GRIN lens. In one embodiment, the core diameter of the GRIN lens is in a range from about 50 to 500 μm with outside diameters in a range from about 60 to 1000 μm . The relative index difference values are preferably in a range from about 0.5 to 3% in high silica compositions compatible with splicing to fibers used in optical communication systems.

[0031] For the hyperbolic lens case where $r_3 = \infty$, i.e., beam at plane **(3)** is planar wavefront, and $w_3 = w_2$, the length of the GRIN lens **308** simplifies to a quarter pitch. In this simple case, the mode field radii w_3 and w_4 are related to the GRIN lens parameters by the following equation:

$$w_3 \cdot w_4 = \frac{\lambda}{\pi n g} \quad (3a)$$

where

10

$$g = \frac{(2\Delta)^{1/2}}{a} \quad (3b)$$

where g is a focusing parameter, a is the radius of the core of the GRIN lens, and Δ is the relative index difference between the core and cladding of the GRIN lens. The formula for quarter pitch ($L/4$) is given by:

$$\frac{L}{4} = \frac{\pi \cdot a}{2 \cdot ((2\Delta)^{1/2})} \quad (3c)$$

where

$$\Delta = (n_1^2 - n_2^2) / (2 \cdot n_1^2) \quad (3d)$$

where L is pitch, n_1 is the refractive index of the core of the GRIN lens, and n_2 is the refractive index of the cladding of the GRIN lens.

[0032] For a non-quarter pitch GRIN lens, the Gaussian beam transformation can be calculated using the ABCD matrix procedures developed by Emkey et al. (Emkey, William L. and Jack, Curtis A., "Analysis and Evaluation of Graded-Index Fiber Lenses." Journal of Lightwave Technology, Vol. LT-5, No. 9, (1987): 1156-1164.) This approach uses a complex beam parameter " q ," which is defined as:

$$\frac{1}{q(z)} = \frac{1}{r(z)} - i \frac{\lambda}{\pi w^2(z)n} \quad (4a)$$

where r is the radius of curvature of a Gaussian beam, w is the Gaussian mode field radius, λ is the free-space wavelength, and n is refractive index. The transformation of $q(z)$ from plane (4), containing the end face of the single-mode pigtail fiber 310, to plane (1), containing the final beam waist of the fiber lens 304, is given by:

$$q_1 = \frac{Aq_4 + B}{Cq_4 + D} \quad (4b)$$

where q_1 and q_4 are the complex beam parameters at the planes (1) and (4), respectively.

[0033] The terms A, B, C, D are elements of the ray matrix relating the ray parameters of plane (4) to plane (1) and are obtained from the following expression:

$$\begin{bmatrix} A & B \\ C & D \end{bmatrix} = M_1 M_2 M_3 M_4 \quad (5a)$$

where M_1 is the transformation of the ray parameters between plane (1) and plane (2) and is expressed as follows:

$$M_1 = \begin{bmatrix} 1 & z \\ 0 & 1 \end{bmatrix} \quad (5b)$$

where z is the final beam waist location relative to the tip of the hyperbolic lens. M_2 is the transformation of the ray parameters in the hyperbolic lens and is expressed as follows:

$$M_2 = \begin{bmatrix} 1 & 0 \\ -(n_2 - n_1)/n_2 r_2 & n_1/n_2 \end{bmatrix} \quad (5c)$$

M_3 is the transformation of the ray parameters in the GRIN lens and is expressed as follows:

$$M_3 = \begin{bmatrix} \cos(gL) & \sin(gL)/g \\ -g \sin(gL) & \cos(gL) \end{bmatrix} \quad (5c)$$

where g is given by equation (3b) for a GRIN lens having length L and refractive index profile given by:

$$n'(r) = n(1 - g^2 r^2)^{1/2} \quad (5d)$$

where r is the radial position from the lens axis. M_4 is the transformation of the ray parameters from a medium of index n_1 to n at plane (4) and is expressed as follows:

$$M_4 = \begin{bmatrix} 1 & 0 \\ 0 & n_1/n \end{bmatrix} \quad (5e)$$

The length L and focusing parameter g of the GRIN lens can be adjusted so that the mode field radius w_4 at plane (4) is transformed to as close as possible to the mode field radius w_p of the single-mode pigtail fiber after the beam goes through the GRIN lens.

[0034] A hyperbolic lens focuses a collimated beam to a diffraction-limited spot but cannot focus a non-collimated beam to a diffraction limited spot because it does not make the path lengths of all the rays equal at a spot. For a GRIN lens having a quarter pitch, the beam at the output face of the GRIN lens is collimated. Hence, if a hyperbolic lens follows a quarter-pitch GRIN lens, the beam from the single-mode pigtail fiber would be focused to a diffraction-limited spot. For a GRIN lens that does not have a quarter pitch, the output beam at the end of the GRIN lens would be diverging or converging, depending on whether the length of the GRIN lens is shorter or longer than quarter pitch. Therefore, the GRIN lens is preferably designed at or close to quarter pitch. It should be noted, however, that there are applications where it would be desirable to have non-quarter pitch GRIN lens. For these applications, the inventors provide a near-hyperbolic lens that can focus a non-collimated beam to a diffraction-limited spot.

[0035] Table 1 below indicates the MFD and radius of curvature of the output beam (R) as a function of GRIN lens length (Z). The parameters used in the calculation are as follows: core radius $a = 50 \mu\text{m}$, relative index difference $\Delta = 0.01$, operating wavelength $\lambda = 1550 \text{ nm}$, and mode field radius of single-mode pigtail fiber $w_p = 10.6 \mu\text{m}$.

Table 1

Z(mm)	MFD (μm)	R(mm)
0.15	9.544436065	0.276522
0.16	9.880469672	0.302607
0.17	10.19672103	0.333614
0.18	10.49111006	0.370933
0.19	10.76181305	0.416623
0.2	11.00723608	0.473827
0.21	11.22599466	0.547572
0.22	11.41689802	0.646393
0.23	11.57893731	0.786001
0.24	11.7112765	0.99881
0.25	11.81324573	1.364093
0.26	11.88433631	2.140502
0.27	11.92419729	4.933849
0.2776	11.9334793	472.7168
0.28	11.93263319	-16.3388
0.29	11.90960273	-3.07433
0.30	11.85521866	-1.69397
0.31	11.76974837	-1.16665
0.32	11.65361566	-0.88767
0.33	11.50740347	-0.71467
0.34	11.33185804	-0.59666
0.35	11.12789463	-0.51087
0.36	10.89660521	-0.44559
0.37	10.63926875	-0.39422
0.38	10.3573647	-0.35272
0.39	10.05259072	-0.31854
0.4	9.726885718	-0.28996

[0036] For the design shown in Table 1, the pitch length of the GRIN is approximately 1110 μm (or 1.11 mm). Using equation (3c), the quarter pitch is approximately 277.6 μm (or 0.2776 mm). For GRIN lens length close to quarter pitch, R is very large. For GRIN lens length below quarter pitch, R is diverging. For example, for GRIN lens length of 260 μm , R is approximately 2.14 mm. For GRIN lens length above quarter pitch, R is converging. For example, for GRIN lens length of 290 μm , R is approximately -3.07 mm. For the GRIN lens lengths where R is converging or diverging, a near-hyperbolic shape, which is a modified hyperbolic shape with a correction factor that compensates for beam curvature, is needed to achieve a focused spot that is diffraction-limited.

[0037] A near-hyperbolic lens profile can be determined with reasonable accuracy by calculating the optical and physical path length changes that need to be made to a hyperbolic profile to compensate for beam curvature. Figure 4A shows a planar beam wavefront **400**, which is produced if the GRIN lens length is at or near quarter pitch, and a diverging beam wavefront **402**, which is produced if the GRIN lens length is shorter than quarter pitch. Compared to the optical path length of the planar beam wavefront **400**, the optical path length of the diverging beam wavefront **402** is reduced away from the optical axis **404**. The optical path length difference, $L_{\text{opt}}(r)$, as a function of the radial distance from the optical axis **404** can be calculated using the formula:

$$L_{\text{opt}}(r) = R(1 - \cos\phi) \quad (6a)$$

where

$$\phi = \sin^{-1}(r/R) \quad (6b)$$

The physical path length difference, $L_p(r)$, is given by

$$L_p(r) = \frac{L_{opt}(r)}{(n-1)} \quad (6c)$$

where n is the index of the lens material. In a similar fashion, the near-hyperbolic shape for GRIN lens lengths longer than quarter pitch, i.e., converging beam wavefront, can be calculated. In this case, the optical path length difference needs to be increased as a function of distance from optical axis. Figure 4B shows the schematic of the changes made to a hyperbolic shape 406 to achieve a near-hyperbolic shape 408 that can focus a diverging beam wavefront into a diffraction limited spot.

[0038] For a specific example of a GRIN lens length of 200 μm with a radius of curvature (R) of 473.8 μm , the optical path length deviation from the hyperbolic shape as a function of the radial position from optical axis is given in Table 2.

Table 2

r (μm)	L_{opt}
2	0.004228
4	0.016913
6	0.038054
8	0.067652
10	0.105704
12	0.152212
14	0.207173
16	0.270587
18	0.342453
20	0.42277
22	0.511536

[0039] The physical path length difference is calculated from the optical path length by dividing it by $(n-1)$, where n is the index of the lens material. As can be seen from Table 2, for large radius of curvature, the modification from the hyperbolic shape is quite small for small distances from the optical axis. However, the deviation becomes larger away from optical axis and for small radii of curvatures. The calculation shown above is meant to show an example of a procedure for determining the near-hyperbolic shape. A more accurate determination of the near-hyperbolic shape can be made using appropriate lens design models.

[0040] In accordance with the present invention, the length of each GRIN lens used in a fiber lens may be different than the quarter pitch when necessary. As a result, and in accordance with the present invention, the same blank may be used to draw GRIN lenses for use in various applications. Because the refractive index profile of the blank need not be changed, the blank making process and GRIN lens making process may be simplified. Accordingly, the same blank can be used for different mode-transforming applications. The blank is preferably redrawn to different outside diameters for different applications, and the resulting GRIN lens may be cut or cleaved to different lengths to meet the requirements for different applications. GRIN lens parameters such as GRIN lens quarter pitch may be determined using the procedure previously described. In the present invention, the near-hyperbolic lens removes the restriction that the GRIN lens must be quarter pitch to achieve a diffraction-limited spot. The near-hyperbolic shape effectively combines the function of a hyperbolic lens and a spherical lens that corrects the residual curvature.

[0041] In one example, which is not to be construed as limiting the invention as otherwise described herein, a Corning SMF-28[®] fiber is used as a single-mode pigtail fiber. The pigtail fiber is spliced to one end of a GRIN lens, and a near-hyperbolic lens is formed at the other end of the GRIN lens. The distance between the splice and the tip of the hyperbolic lens is approximately 275 μm . The GRIN lens has a core diameter of 50 μm and an outside diameter of 125 μm . The relative index difference between the core and cladding of the GRIN lens is 1%. Figure 5 shows a graph of far-field intensity distribution as a function of far-field divergence angle for this example. The characterization is done at 1.31 μm , and far-

field full-width half-maximum (FWHM) divergence angle of the fiber lens is approximately 20°. The graph shows that the intensity distribution is quite Gaussian.

[0042] One of the applications of the fiber lens of the present invention is in coupling of optical signals between an optical fiber and a semiconductor optical amplifier (SOA) or other waveguide. Typical requirements for these applications include: MFD < 3.0 μm, distance to beam waist >10 μm, return loss > 45 dB, and a robust lens shape to prevent breakages during component assembly. For SOA and waveguide applications, the fiber lens has to transform the mode field of the pigtail fiber to match that of the waveguide or the SOA. The waveguides and a number of the SOA devices currently under consideration now have MFDs that are substantially round. MFDs for SOAs are in the range of 2.5-3.8 μm at 1550 nm. These values correspond to far-field full-width half-maximum (FWHM) divergence angles as high as 18-22 degrees. Far-field divergence half angle (θ) at ~13.5% (1/e²) intensity level is given by:

$$\theta = \frac{\lambda}{\pi w_0} \quad (7)$$

where λ is the wavelength of the light and w₀ is the mode field radius of the beam. MFD is 2w₀.

[0043] Another attribute of the SOAs that has impact on the SOA assembly process and the desirable features of fiber lenses is the angled facet of the SOA. For reduced back reflections, the facets of the SOAs are angled at approximately 15°. With angled facet, it becomes important that the gap between the facet edge and the fiber lens tip be reasonable. Otherwise, as the fiber lens is being aligned to the SOA for optimum coupling, there is a good probability that the fiber lens will come in contact with the SOA facet and damage it. Most of the currently available fiber lenses that have MFDs in the 2.5-3.8 μm range at 1550 nm operating wavelength have working distances as small as 5-10 μm. Hence, it would be advantageous to increase it to greater than 15-20 μm to improve this attribute and reduce the probability of damaging the SOA during assembly process. Also, the SOAs are quite

sensitive to back reflections. If the working distance is large, then a smaller fraction of back reflection from the fiber lens tip reaches the SOA. This also improves the performance and stability of the SOA.

[0044] Another useful feature for SOA applications is the intensity distribution and wavefront characteristics of the light focused by the fiber lens. The wavefront characteristics should match the mode field intensity distributions between the SOA and the pigtail fiber as closely as possible in both size, intensity distribution and phase. This implies that the focused light from the pigtail fiber through the fiber lens has to have dimension in the 2.5-3.8 μm range and be as Gaussian as possible. Currently available fiber lenses achieve this property at the larger MFDs, but not so well at the smaller MFDs. This leads to higher coupling losses and degrades the SOA performance. It is advantageous to improve this performance.

[0045] Another attribute is the robustness of the fiber lens. For example, if the fiber lens design is such that it has a very small and fragile tip, during the various processing steps involved in the preparation of the fiber lens for assembly into a SOA package, there is a probability that the lens tip will get damaged and degrade the performance. A physically robust fiber tip which is not fragile would be a useful attribute. Another useful attribute will be a lens design and process that is stable and has more tolerance to process variations. For example, if the lens tip has a radius of curvature of 10 μm , a very small variation of 1 μm in the radius of curvature would be a 10% variation and can change the focusing characteristics significantly. The same 1 μm variation in a 25 μm radius of curvature design may not degrade the performance to the same extent. In the present invention, some of these issues are addressed and improved.

[0046] Another application of the fiber lens of the present invention is in coupling of optical signals between an optical fiber and a laser diode. The laser diodes used for transmission lasers have far-field divergence angles as high as 40°, which corresponds to a MFD of about 0.8 μm at a wavelength of 1550 nm. The aspect ratio of the laser radiation in x- and y-directions varies from 1 to 4. The closer the MFD of the lens is matched to this, the

higher the coupling efficiency. In this disclosure, the fiber lenses are generally geared towards devices that have aspect ratios closer to 1. A distance to beam waist greater than 10 μm is desirable, since this will prevent the lens from damaging laser during assembly. The preferred performance characteristics of the fiber lens for this application are as follows: MFD < 3.0 μm or divergence angle > 22° at 1550-nm operating wavelength, return loss > 45 dB, distance to beam waist >10 μm , and lens-to-lens coupling efficiency greater than 90%.

[0047] Another application of the fiber lens of the present invention is in coupling of optical signals passed between an optical fiber and a detector. Unlike the above applications where not only the spot size but the intensity distribution and phase front errors matter, the detector applications need the control of the spot size and the amount of power that is within a certain area only. For this application, spot sizes less than 3-5 μm with working distances up to 50-60 μm would be advantageous for low cost assembly.

[0048] The fiber lens of the present invention provides one or more advantages. The fiber lens allows coupling of optical signals between optical devices. The hyperbolic lens or near-hyperbolic lens formed at the tip of the fiber lens is mechanically robust and is less likely to get damaged and degrade in performance in comparison to, for example, a tapered lens. The multimode parameters of the GRIN lens and the shape of the hyperbolic or near-hyperbolic lens can be controlled to achieve small MFDs with reasonably Gaussian intensity patterns and long working distances. The hyperbolic lens focuses a collimated beam to a diffraction-limited spot. The near-hyperbolic lens corrects for wavefront curvature in a non-collimated beam, allowing the beam to be focused to a diffraction-limited spot.

[0049] While the invention has been described in terms of several preferred embodiments, there are alterations, permutations, and equivalents which fall within the scope of this invention. It is therefore intended that the following appended claims be interpreted as including all such alterations, permutations, and equivalents as fall within the true spirit and scope of the invention.

CLAIMS

What is claimed is:

1. A fiber lens, comprising:
a graded-index lens;
a single-mode fiber disposed at a first end of the graded-index lens; and
a refractive lens having a hyperbolic or near-hyperbolic shape disposed at a second end of the graded-index lens to focus a beam from the single-mode fiber to a diffraction-limited spot.
2. The fiber lens of claim 1, wherein the hyperbolic shape focuses a collimated beam into the diffraction-limited spot.
3. The fiber lens of claim 1, wherein the near-hyperbolic shape includes a correction factor that compensates for beam curvature and allows focusing of a non-collimated beam into the diffraction-limited spot.
4. The fiber lens of claim 1, wherein a spacer rod is interposed between the refractive lens and the graded-index lens.
5. The fiber lens of claim 1, wherein a spacer rod is interposed between the graded-index lens and the single-mode fiber.
6. The fiber lens of claim 1, wherein a mode field diameter of the spot is less than 10 μm .
7. The fiber lens of claim 6, wherein the mode field diameter of the spot is in a range of approximately 2 to 5 μm .
8. The fiber lens of claim 6, wherein a working distance of the fiber lens is greater than approximately 5 μm .

9. The fiber lens of claim 6, wherein a working distance of the fiber lens is in a range from approximately 20 to 60 μm .
10. The fiber lens of claim 6, wherein a ratio of distance from a tip of the refractive lens to the beam waist to the mode field diameter at the beam waist is greater than approximately 5.
11. The fiber lens of claim 1, wherein a diameter of a core of the graded-index lens is in a range from approximately 50 to 500 μm .
12. The fiber lens of claim 11, wherein an outer diameter of the graded-index lens is in a range from approximately 60 to 1,000 μm .
13. The fiber lens of claim 1, wherein a relative index difference of the graded-index lens is in a range from approximately 0.5 to 3 %.
14. The fiber lens of claim 1, wherein an operating wavelength of the fiber lens is in a range from 250 to 2,000 nm.
15. A fiber lens, comprising:
a single-mode fiber; and
a lens disposed at an end of the single-mode fiber;
wherein a mode field diameter at a beam waist of a beam emerging from a tip of the lens is less than 10 μm and a ratio of distance from the tip of the lens to the beam waist to the mode field diameter at the beam waist is greater than 5.
16. The fiber lens of claim 15, wherein the lens comprises a hyperbolic or near-hyperbolic lens disposed at an end of a graded-index lens.
17. The fiber lens of claim 16, wherein a spacer rod is interposed between the hyperbolic or near-hyperbolic lens and the graded-index lens.

18. A method of making a fiber lens, comprising:
 - splicing a single-mode fiber to a graded-index fiber;
 - cutting the graded-index fiber to a desired length;
 - rounding a tip of the graded-index fiber into a hyperbolic or near-hyperbolic shape.
19. The method of claim 18, further comprising shaping the tip of the graded-index fiber into a cone or wedge having an apex angle defined by asymptotes of a hyperbola prior to rounding the tip of the graded-index fiber.
20. A method of making a fiber lens, comprising:
 - splicing a single-mode fiber to a graded-index fiber;
 - cutting the graded-index fiber to a desired length;
 - splicing a coreless fiber to the graded-index fiber;
 - cutting the coreless fiber to a desired length; and
 - rounding a tip of the coreless fiber into a hyperbolic or near-hyperbolic shape.

1/8

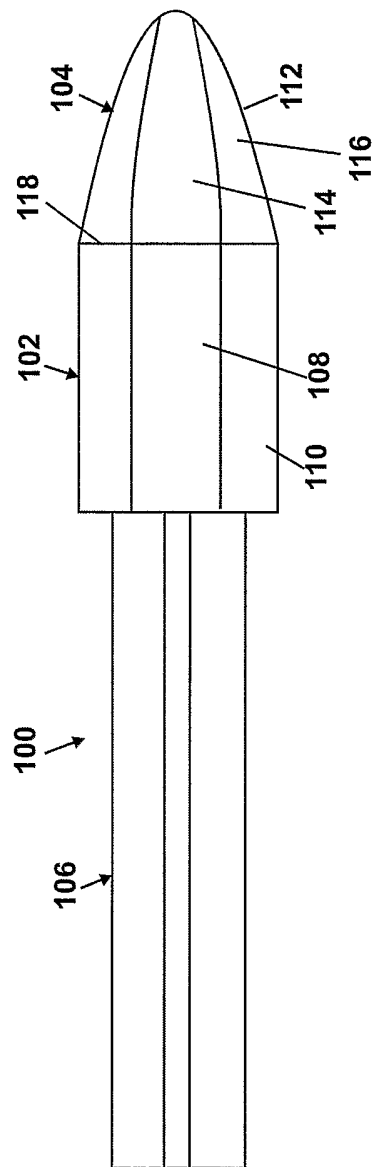

FIGURE 1A

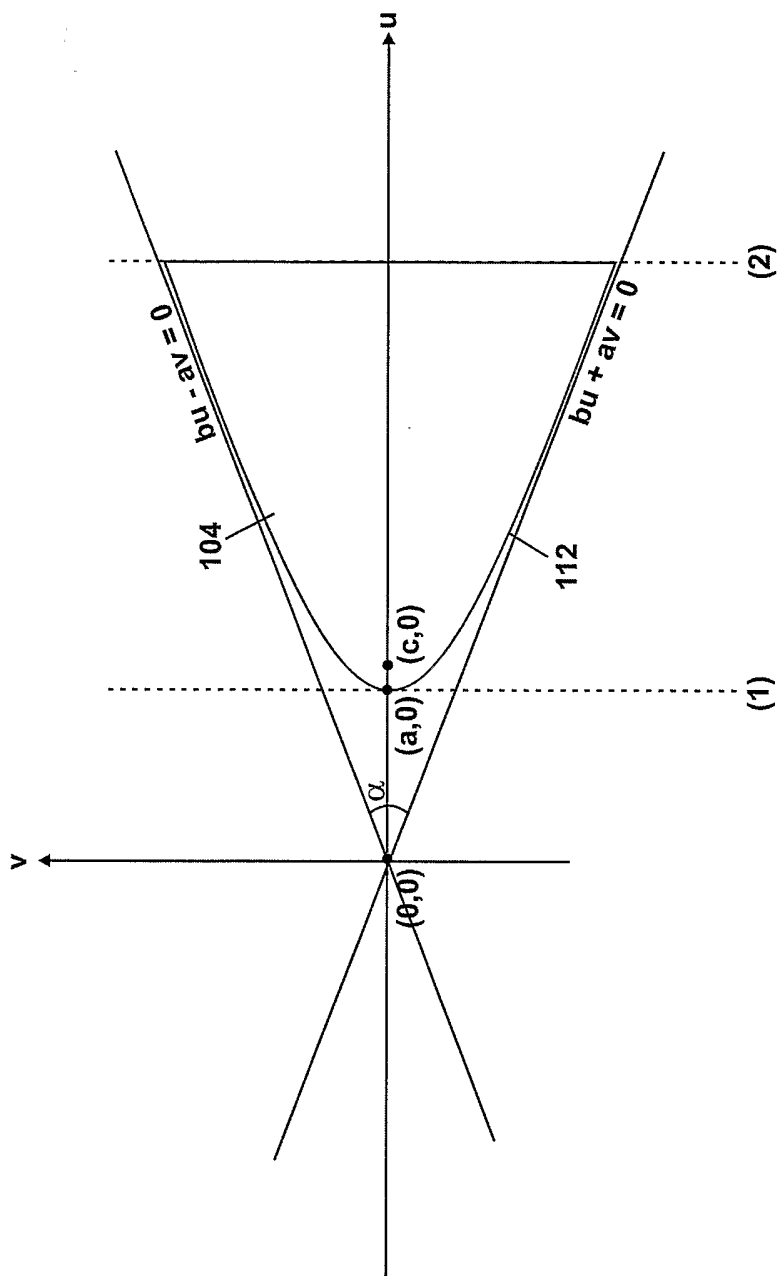

FIGURE 1B

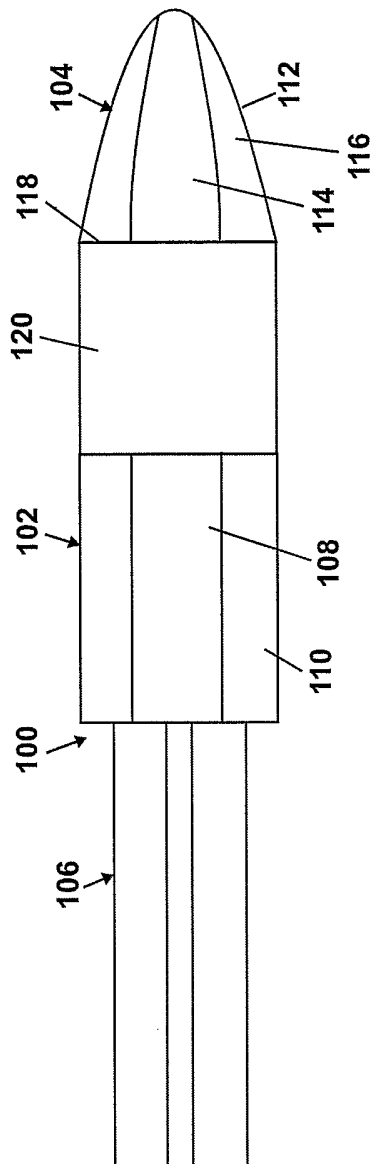

FIGURE 1C

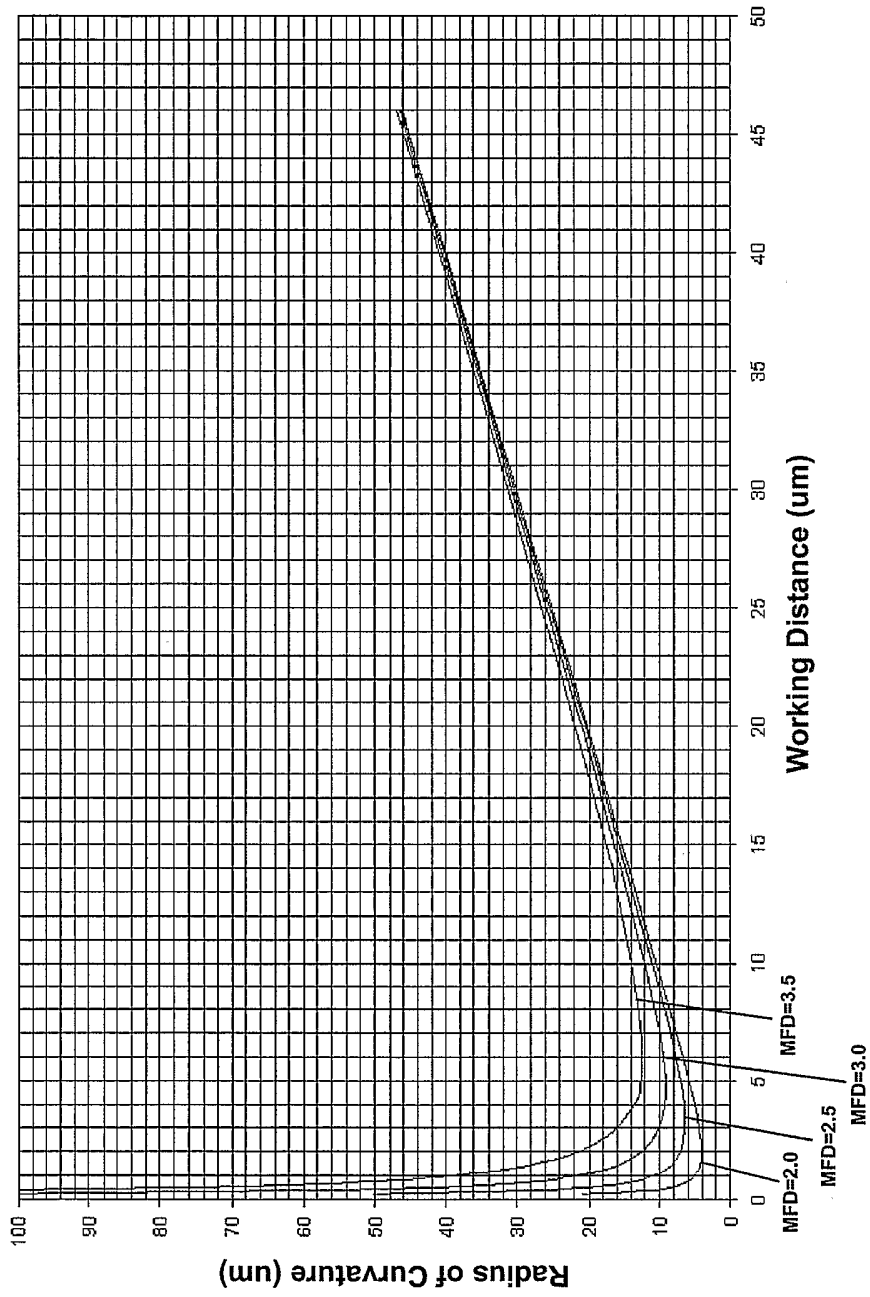

FIGURE 2A

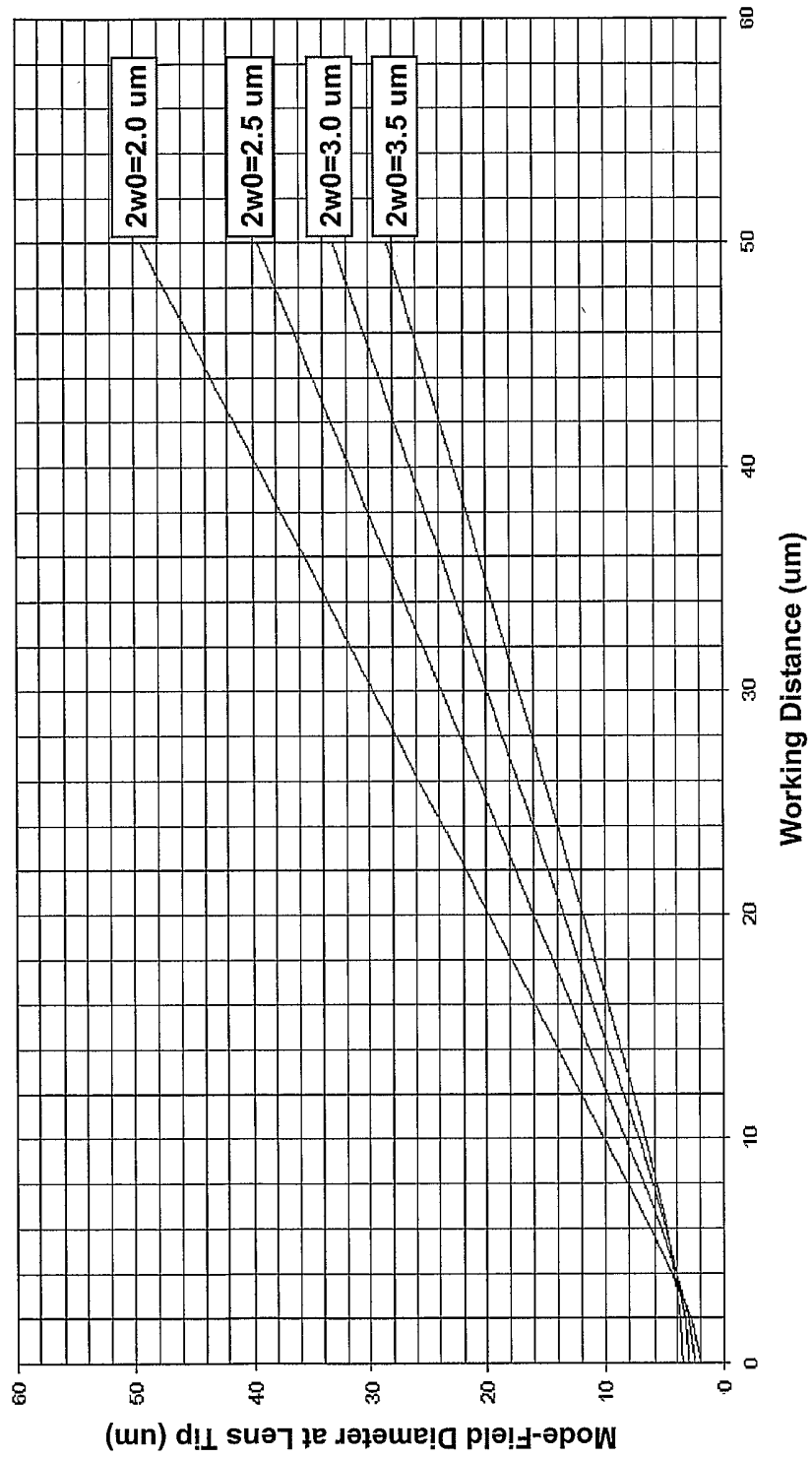

FIGURE 2B

6/8

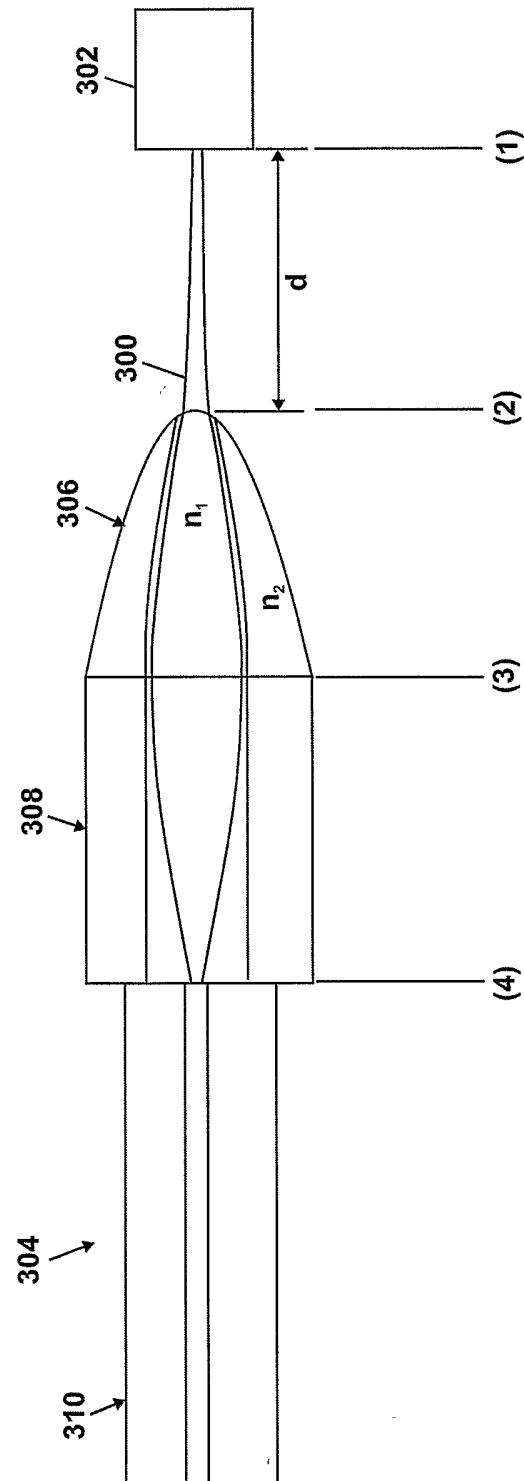
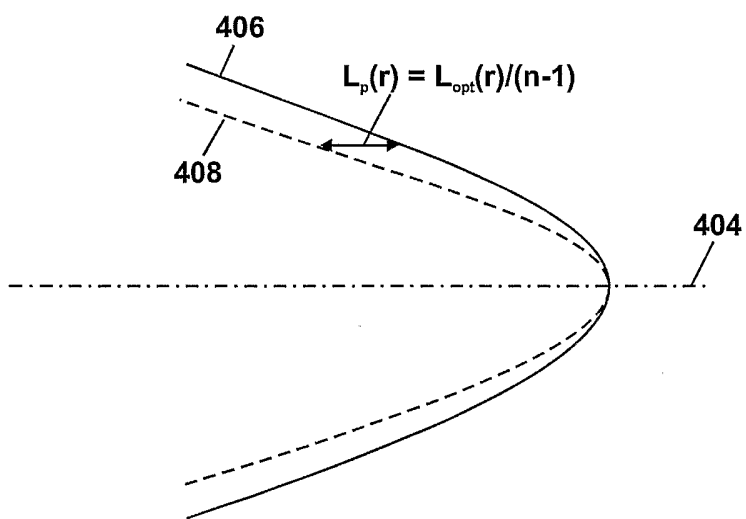
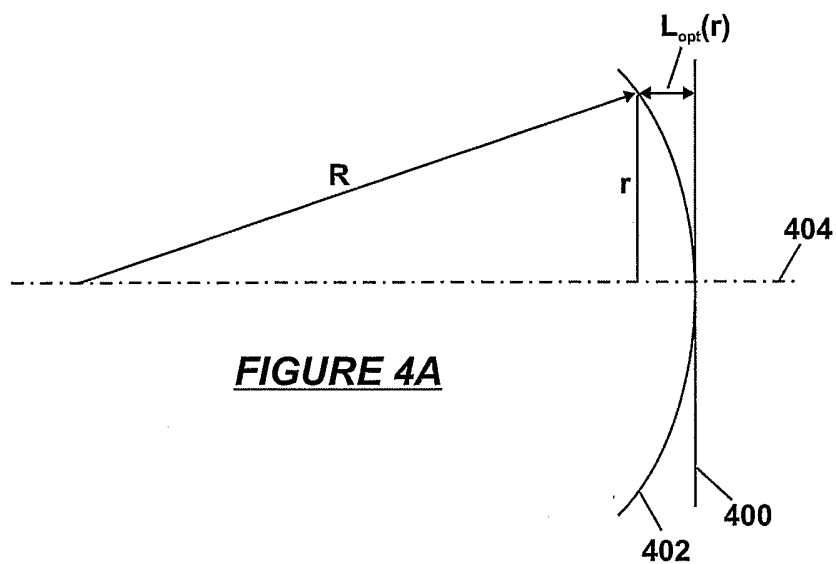

FIGURE 3



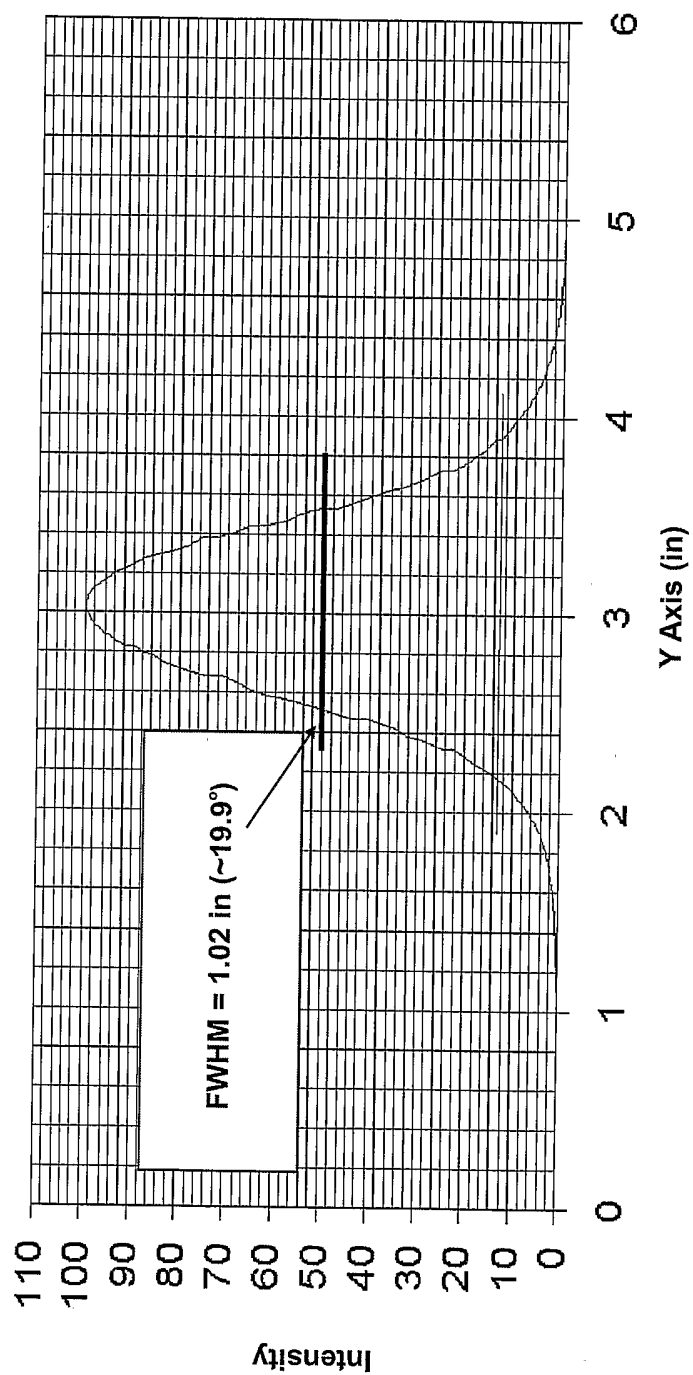

FIGURE 5

INTERNATIONAL SEARCH REPORT

PCT/US 03/39641

A. CLASSIFICATION OF SUBJECT MATTER
 IPC 7 G02B6/32 G02B6/25

According to International Patent Classification (IPC) or to both national classification and IPC

B. FIELDS SEARCHED

Minimum documentation searched (classification system followed by classification symbols)
 IPC 7 G02B

Documentation searched other than minimum documentation to the extent that such documents are included in the fields searched

Electronic data base consulted during the international search (name of data base and, where practical, search terms used)
 EPO-Internal, PAJ, WPI Data

C. DOCUMENTS CONSIDERED TO BE RELEVANT

Category °	Citation of document, with indication, where appropriate, of the relevant passages	Relevant to claim No.
X	US 5 638 471 A (SEMO JACK ET AL) 10 June 1997 (1997-06-10) abstract; figures 11,12 column 4, line 45 -column 6, line 52	1,2,4, 6-17
A	---	3,5
X	PATENT ABSTRACTS OF JAPAN vol. 2000, no. 14, 5 March 2001 (2001-03-05) -& JP 2000 304965 A (NAMIKI PRECISION JEWEL CO LTD;SHIRAISHI KAZUO), 2 November 2000 (2000-11-02) abstract; figure 1 paragraphs '0007!', '0008!', '0014!', '0015!', '0023!', '0024!	1,2, 6-16,18, 19
A	---	3,5
	-/--	

Further documents are listed in the continuation of box C. Patent family members are listed in annex.

° Special categories of cited documents :

A document defining the general state of the art which is not considered to be of particular relevance	*T* later document published after the international filing date or priority date and not in conflict with the application but cited to understand the principle or theory underlying the invention
E earlier document but published on or after the international filing date	*X* document of particular relevance; the claimed invention cannot be considered novel or cannot be considered to involve an inventive step when the document is taken alone
L document which may throw doubts on priority claim(s) or which is cited to establish the publication date of another citation or other special reason (as specified)	*Y* document of particular relevance; the claimed invention cannot be considered to involve an inventive step when the document is combined with one or more other such documents, such combination being obvious to a person skilled in the art.
O document referring to an oral disclosure, use, exhibition or other means	*Z* document member of the same patent family
P document published prior to the international filing date but later than the priority date claimed	

Date of the actual completion of the international search 7 May 2004	Date of mailing of the international search report 19/05/2004
-----------------------------------------------------------------------------	----------------------------------------------------------------------

Name and mailing address of the ISA European Patent Office, P.B. 5818 Patentlaan 2 NL - 2280 HV Rijswijk Tel. (+31-70) 340-2040, Tx. 31 651 epo nl, Fax: (+31-70) 340-3016	Authorized officer Riblet, P
----------------------------------------------------------------------------------------------------------------------------------------------------------------------------------------	-------------------------------------

INTERNATIONAL SEARCH REPORT

PCT/US 03/39641

C.(Continuation) DOCUMENTS CONSIDERED TO BE RELEVANT		
Category °	Citation of document, with indication, where appropriate, of the relevant passages	Relevant to claim No.
X	US 5 751 871 A (KRIVOSHLYKOV SERGEJ G ET AL) 12 May 1998 (1998-05-12) page 1, line 10-21 column 4, line 22 -column 5, line 22; figures 1,2	1
A	---	3
X	EP 0 155 379 A (SIEMENS AG) 25 September 1985 (1985-09-25) abstract; figures 2,3 page 7, line 11-29	1,2, 6-16,18, 20
A	---	3,5
X,P	WO 03/076994 A (CORNING INC) 18 September 2003 (2003-09-18) page 14, line 2-12; figures page 15, line 25 -page 16, line 26 page 22, line 19 -page 23, line 13	1,2,4-20
A	US 5 446 816 A (SHIRAISHI KAZUO ET AL) 29 August 1995 (1995-08-29) abstract; figures	1-20
A	BLUDAU W ET AL: "LOW-LOSE LASER-TO-FIBER COUPLING WITH NEGLIGIBLE OPTICAL FEEDBACK" JOURNAL OF LIGHTWAVE TECHNOLOGY, IEEE. NEW YORK, US, vol. LT-3, no. 2, 1 April 1985 (1985-04-01), pages 294-302, XP000601805 ISSN: 0733-8724 the whole document	1-20
A	EP 0 558 230 A (AMERICAN TELEPHONE & TELEGRAPH) 1 September 1993 (1993-09-01) abstract; figures	1-20

INTERNATIONAL SEARCH REPORT

PCT/US 03/39641

Patent document cited in search report		Publication date	Patent family member(s)	Publication date
US 5638471	A	10-06-1997	FR 2718854 A1 DE 69524801 D1 DE 69524801 T2 EP 0677758 A1	20-10-1995 07-02-2002 14-08-2002 18-10-1995
JP 2000304965	A	02-11-2000	NONE	
US 5751871	A	12-05-1998	NONE	
EP 0155379	A	25-09-1985	AT 86759 T DE 3486097 D1 EP 0155379 A2 JP 60205515 A	15-03-1993 15-04-1993 25-09-1985 17-10-1985
WO 03076994	A	18-09-2003	US 2003165292 A1 WO 03076992 A1 WO 03076993 A1 WO 03076994 A1 US 2003165290 A1 US 2003165291 A1	04-09-2003 18-09-2003 18-09-2003 18-09-2003 04-09-2003 04-09-2003
US 5446816	A	29-08-1995	JP 3282889 B2 JP 7049432 A	20-05-2002 21-02-1995
EP 0558230	A	01-09-1993	US 5256851 A CA 2085498 A1 DE 69309748 D1 DE 69309748 T2 EP 0558230 A1 JP 6043336 A KR 155393 B1 SG 65542 A1	26-10-1993 29-08-1993 22-05-1997 30-10-1997 01-09-1993 18-02-1994 15-12-1998 22-06-1999