

E. F. CROWTHER.

JOURNAL BOX AND ROLLER BEARING FOR RAILWAY CAR AXLES.

(Application filed Aug. 26, 1901.)

(No Model.)

2 Sheets—Sheet 1.

Fig. 1.

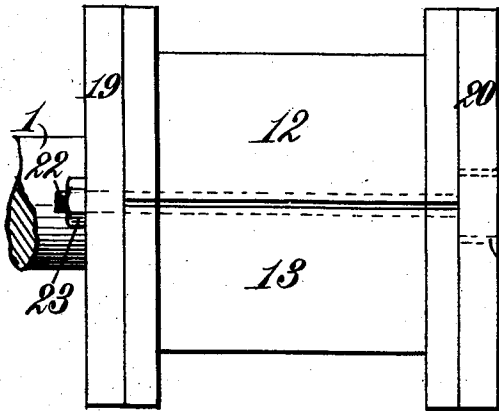

Fig. 2.

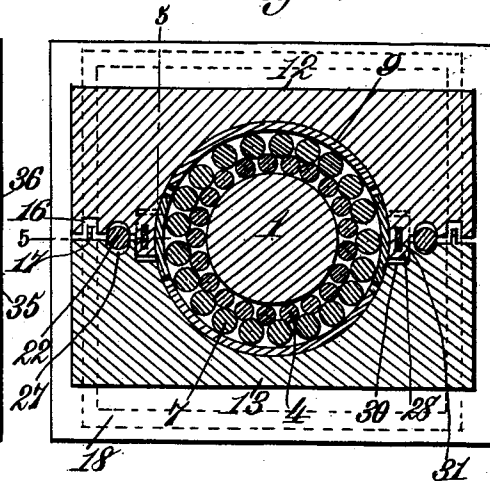

Fig. 3.

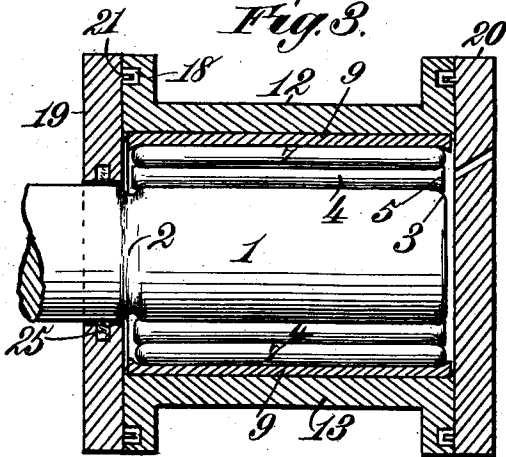

Fig. 4.

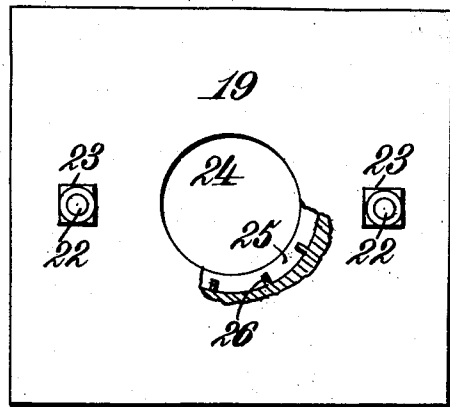
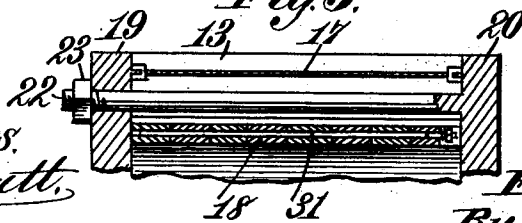

Fig. 5.



Witnesses.  
Abel C. Smith,

Howard Dume.

Inventor  
Edgar F. Crowther.

By James L. Norris,  
Att'y.

E. F. CROWTHER.

JOURNAL BOX AND ROLLER BEARING FOR RAILWAY CAR AXLES.

(Application filed Aug. 26, 1901.)

(No Model.)

2 Sheets—Sheet 2.

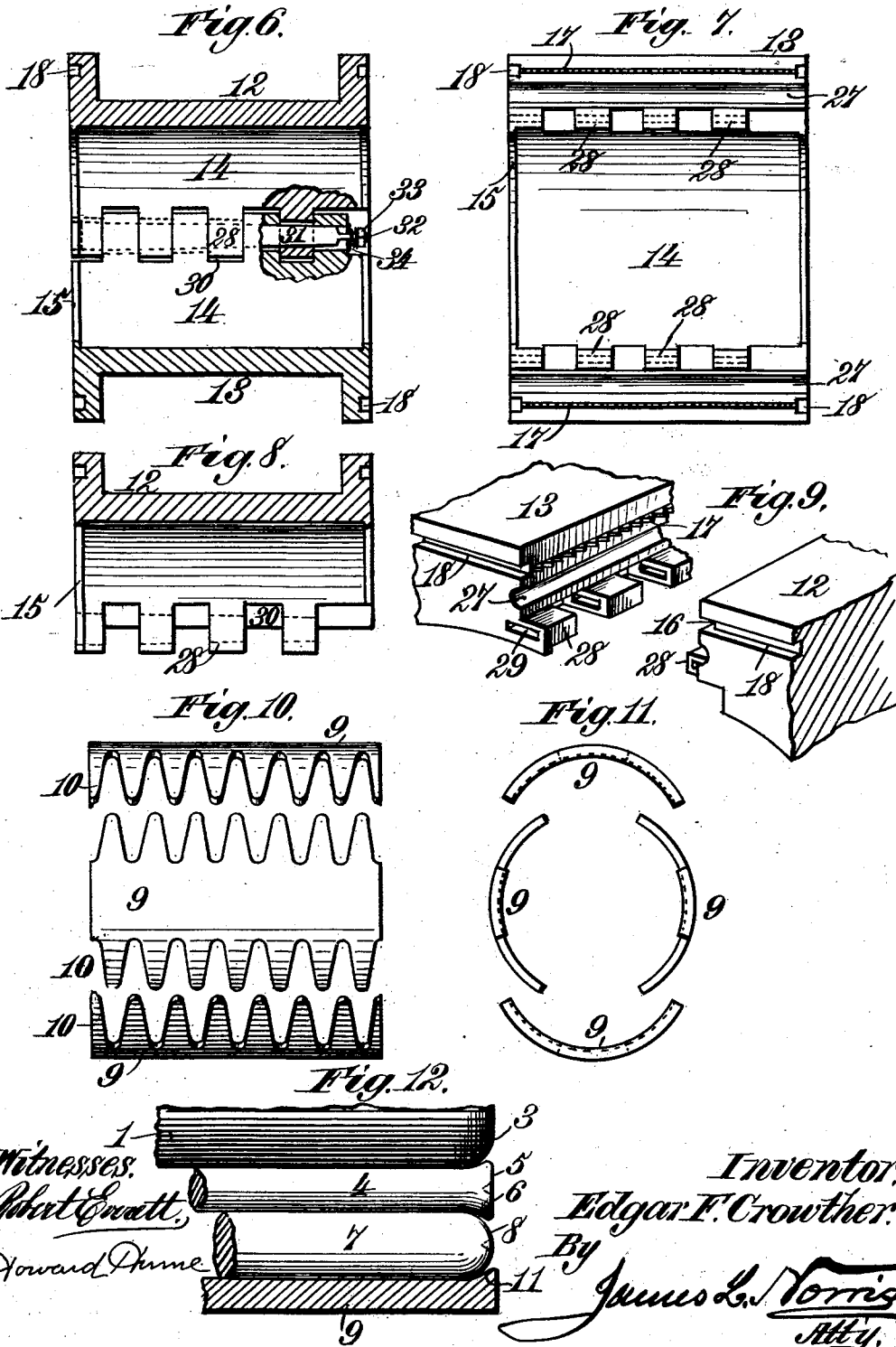

Witnesses:  
*Robert Crowther,*  
*Howard Dume*

Inventor:  
*Edgar F. Crowther.*  
 By *James L. Norris,*  
*Att'y.*

# UNITED STATES PATENT OFFICE.

EDGAR F. CROWTHER, OF VICKSBURG, MISSISSIPPI.

JOURNAL-BOX AND ROLLER-BEARING FOR RAILWAY-CAR AXLES.

SPECIFICATION forming part of Letters Patent No. 700,179, dated May 20, 1902.

Application filed August 26, 1901. Serial No. 73,332. (No model.)

To all whom it may concern:

Be it known that I, EDGAR F. CROWTHER, a citizen of the United States, residing at Vicksburg, in the county of Warren and State of Mississippi, have invented new and useful Improvements in Journal-Boxes and Roller-Bearings for Railway-Car Axles, of which the following is a specification:

This invention relates to a journal-box and roller-bearing for railway-car axles, and has for its object to provide a simple, durable, and efficient device of the character referred to wherein friction and wear will be reduced to a minimum and from which dust, grit, and the like will be effectually excluded.

To these ends my invention consists in the features and in the construction, combination, and arrangement of parts hereinafter described, and particularly pointed out in the claims following the description, reference being had to the accompanying drawings, forming a part of this specification, wherein—

Figure 1 is a view in side elevation of my improved box and bearing. Fig. 2 is a transverse vertical sectional view thereof. Fig. 3 is a vertical longitudinal sectional view of the same. Fig. 4 is an end view, a portion of the end cap being broken away. Fig. 5 is a detail sectional view taken on the line 5 5 of Fig. 2. Fig. 6 is a vertical central sectional view of the journal-box, the journal, rollers, and sleeve being removed. Fig. 7 is a top plan view of the lower half-box. Fig. 8 is a vertical longitudinal central-sectional view of the upper half-box. Fig. 9 is a detail perspective view illustrating two abutting portions of the two half-boxes. Fig. 10 is a vertical longitudinal sectional view of the contractible sleeve, the sections thereof being shown separated. Fig. 11 is an end view thereof; and Fig. 12 is an enlarged detail view showing the relative arrangement of the journal, rollers, and sleeve.

Referring to the drawings, the numeral 1 indicates a railway-car axle which is provided near its end with a circumferential groove 2 and at its end with a rounded edge 3. Arranged around the axle is a series of anti-friction-rollers 4, each of which is provided at its opposite ends with enlargements 5, (most clearly shown in Fig. 12 of the draw-

ings,) having concave shoulders 6. Disposed around and in contact with the rollers 4 is a series of anti-friction-rollers 7, said rollers being preferably of greater diameter than the rollers 4, and each is provided with rounded ends 8. Surrounding the outer series of rollers 7 is a sectional contractible sleeve consisting of a plurality of segmental sections 9, provided on their adjacent or meeting edges with tapered or approximately wedge-shaped tongues 10, the tongues being so arranged that the tongues of one section project into the spaces between the tongues on the adjacent sections, or, in other words, the adjacent tongues loosely interlock, whereby said sections are immovable relatively to one another, excepting radially. The ends of each of the sections 9 are provided with inwardly-projecting concave shoulders 11, that overhang the rounded ends of the rollers 7. The relative dimensions of the sections 9 and their tongues 10 are such that the ends of the tongues never contact with the bottoms of the spaces between the adjacent tongues under any circumstances. As shown most clearly in Fig. 12 of the drawings, the rounded ends of the rollers 7 and the concave shoulders 6 and 11 are formed on the arcs of different circles, whereby the instant said rounded ends and concave shoulders commence to deviate from a straight line they diverge from one another, and thus do not normally contact. The concave shoulders 6 at the outer ends of the rollers 4 overhang the rounded edge 3 of the outer end of the axle, and the shoulders on the inner ends of said rollers project into the circumferential groove 2 of the axle, whereby the said rollers 4 are held against end movement. The rounded ends 8 of the rollers 7 are confined between the concave shoulders 6 of the rollers 4 and the concave shoulders 11 of the contractible sleeve and are thus held against end movement.

The roller-bearing, constructed as above described, is inclosed within a journal-box constructed as follows: Inclosing the bearing are two approximately rectangular metallic half-boxes 12 and 13, provided on their adjacent faces with semicylindrical recesses 14, which are confined at their ends between inwardly-projecting semi-annular flanges 15, formed integrally with the ends of the boxes. The re-

cesses 14 form seats for the reception of the contractible sleeve, the rollers, and the axle. Formed on the inner face of the upper half-box 12 and parallel with the recess 14 therein are two longitudinal grooves 16, which in practice are filled with cotton or other suitable fibrous material, and preferably a suitable quantity of tar is placed in said grooves before the cotton is inserted therein. On the adjacent face of the other half-box 13 are formed two projecting serrated or toothed ribs 17, which project into the grooves 16 and hold the packing and effectually prevent its displacement. Endless rectangular grooves 18 are formed in the opposite ends of each of the half-boxes and in practice are also packed with cotton and tar in the same manner as the grooves 16. Fitted over the opposite ends of the two half-boxes 12 and 13 are end caps 19 and 20, each consisting of a flat rectangular plate that fits flush against the ends of the half-boxes, and formed on the inner face of each of said plates is an endless rectangular projecting serrated or toothed rib 21, that projects into the adjacent endless groove 18 and engages the packing therein and holds it securely against displacement. The caps 19 and 20 are tightly clamped against the ends of the half-boxes 12 and 13 by bolts and nuts 22 and 23. The upper and lower portions of the grooves 18 are made of such width that the ribs 21 fit loosely thereon in order that the two half-boxes may have a limited movement toward and away from one another, as will hereinafter more fully appear. The inner end cap 19 is provided centrally with a circular aperture 24, through which the axle 1 passes, and the wall of said aperture is provided with an internal annular groove 25, in the bottom of which are formed thin transverse ribs or webs 26. (See Fig. 4.) Cotton and tar are packed in said groove, the ribs 26 engaging the cotton and preventing its displacement. As before stated, the end caps 19 and 20 are clamped and held in place by bolts 22, and said bolts pass through longitudinal grooves 27, formed in the adjacent faces of the two half-boxes parallel with the recesses 14. Each of said grooves is slightly greater than a semicircle in cross-section and are so disposed that the grooves of one half-box register with those of the other half-box to form passages for the reception of the bolts, and by making the said passages slightly larger than the bolts, in the manner described, the half-boxes are permitted to have a limited movement toward and from one another.

The two half-boxes 12 and 13 are adjustably secured together in the following manner: Formed on the inner adjacent edges of each of the half-boxes is a plurality of vertically-projecting lugs 28, formed equidistant apart and each provided with a transverse horizontal slot 29. The lugs on one half-box are so disposed that they alternate with the lugs on the other half-box—that is to say, the

lugs "break joints" with one another, whereby when the two half-boxes are assembled together the lugs interlock, or the lugs of one half-box project between the lugs of the other half-box, and to permit such interlocking the inner edge of each half-box is recessed or mortised between the lugs 28, as at 30, to permit the ends of the lugs on one half-box to project into the recesses or mortises of the other half-box. When the two half-boxes are in place, the slots 29 of one series of lugs register with the slots of the corresponding series of lugs, and loosely fitted in the slots are tapered or wedge-shaped keys 31, each of which is provided at its smaller end with a threaded tenon 32, over which is screwed a nut 33. (See Fig. 6.) Arranged on the tenons between said nuts and the adjacent lugs 28 are coiled springs 34. It will be manifest that by screwing up the nuts 33 the tapered keys will be moved endwise in the slotted lugs and bearing against the outer walls of the slots in the several lugs will draw the two half-boxes together. At the same time the springs 34 will be compressed and will continually operate to draw the keys tighter in the slots. Hence as fast as any wear occurs on any of the parts the springs will automatically act to draw the half-boxes together tighter to compensate for such wear. The outer end cap 20 is provided with two ports or apertures 35 and 36, (see Fig. 1.) the port 35 being for the introduction of lubricant and the port 36 forming a vent for the escape of air during the operation of lubricating the bearing.

In practice the parts are loosely assembled together on the axle in the positions described, and the nuts 33 are screwed up tight, drawing the two half-boxes firmly toward one another, thus contracting the sectional sleeve about the rollers and confining the latter in place. The screws 23 are then tightened up, tightly clamping the end caps against the ends of the half-boxes.

By forming the rollers 4 and 7 in the manner described the enlarged ends 6 of the rollers 4 overhang the rounded outer end of the axle and engage the groove 2 in the latter and prevent endwise movement of said rollers. Said enlarged ends 6 and the concave shoulders 11 of the contractible sleeve also overhang the rounded ends of the rollers 7 and hold the latter against end movement. As before described, however, the said rounded ends and concave shoulders diverge from one another, and hence they are not normally in contact and generate no friction. The described packing surrounds the bearing on all sides and effectually prevents the entrance of dust, grit, and the like. When the parts are first assembled, lubricant is poured into the bearing in the manner described, and the ports 35 and 36 are then plugged up. As fast as any wear occurs the springs 34 automatically operate to draw together the half-boxes and contractible sleeve and tighten up the

parts of the bearing to compensate for such wear.

In Fig. 12 of the drawings I have shown the rollers provided with conical recesses in their ends. These recesses are for the reception of pins that form part of an implement for assembling the rollers in the boxing and form no part of the present invention, the same being included in a separate application for Letters Patent filed concurrently with this application.

Having described my invention, what I claim is—

1. The combination with a railway-car axle having a circumferential groove near its end and having the edge of its end rounded, of a plurality of rollers arranged around the axle and having enlarged concave shoulders on their opposite ends which overhang the rounded end of the axle and engage said circumferential groove, said concave shoulders diverging from the adjacent portions of the axle, and a casing inclosing said rollers, substantially as described.

2. The combination with a railway-car axle having a circumferential groove near its end and having the edge of its end rounded, of a series of rollers arranged around the axle and having enlarged concave shoulders at their opposite ends which overhang the rounded end of the axle and engage said circumferential groove, a second series of rollers arranged around and contacting with the first-named series and having rounded ends lying between the enlarged concave shoulders of the first-mentioned rollers, said rounded ends and concave shoulders diverging from one another, and a casing inclosing said rollers, substantially as described.

3. The combination with a railway-car axle having a circumferential groove near its end and having the edge of its end rounded, of a series of rollers arranged around the axle and having enlarged concave shoulders at their opposite ends which overhang the rounded end of the axle and engage said circumferential groove, a second series of rollers arranged around and contacting with the first-named series and having rounded ends lying between the concave shoulders of the first-named rollers, and a contractible sleeve inclosing said rollers and provided with inwardly-projecting concave shoulders on its opposite ends which overhang the rounded ends of the outer rollers, said rounded ends and concave shoulders diverging from one another, substantially as described.

4. The combination with a railway-car axle having a circumferential groove near its end and having the edge of its end rounded, of a series of rollers arranged around the axle and having enlarged concave shoulders at their opposite ends which overhang the rounded end of the axle and engage said circumferential groove, a second series of rollers arranged around and contacting with the first-named series and having rounded ends lying

between the concave shoulders of the first-named rollers, and a contractible sleeve inclosing said rollers and comprising a plurality of segmental sections provided on their adjacent edges with interlocking tongues, the ends of said sections having inwardly-projecting concave shoulders overhanging the rounded ends of the outer rollers, substantially as described.

5. The combination with a railway-car axle, of a plurality of rollers arranged around the axle, a contractible sleeve surrounding said rollers and comprising a plurality of segmental sections provided on their adjacent edges with interlocking tongues, a two-part journal-box inclosing said sleeve, and means for clamping said two-part box about the sleeve, substantially as described.

6. The combination with a railway-car axle, of a journal-box mounted on the axle and comprising two half-boxes, said half-boxes being provided on their inner adjacent edges with vertically-projecting and interlocking slotted lugs, tapered keys loosely fitted in said slotted lugs, means for adjusting said keys endwise in said lugs to draw the half-boxes together, and means for yieldingly holding said keys in their adjusted positions whereby they will be automatically tightened in said lugs to compensate for wear of the parts, substantially as described.

7. The combination with a railway-car axle, of a journal-box mounted on the axle and comprising two half-boxes provided on their inner adjacent edges with vertically-projecting and interlocking slotted lugs, tapered keys fitted loosely in said slotted lugs and provided at their smaller ends with threaded tenons, nuts screwed over said tenons, and coiled springs arranged on said tenons between said nuts and the adjacent lugs, substantially as described.

8. The combination with a railway-car axle, of a journal-box mounted on the axle and comprising two half-boxes provided on their adjacent edges with vertically-projecting slotted lugs, the lugs of one half-box loosely fitting between the corresponding lugs of the other box, and said inner adjacent edges of the boxes being mortised upon their inner sides between the lugs for the reception of the ends of the opposing lugs, tapered keys fitted in the slotted lugs, means for adjusting said keys endwise in the lugs to draw the half-boxes together, and springs arranged to automatically draw said keys tightly to their seats in the lugs to compensate for wear of the parts, substantially as described.

9. The combination with a railway-car axle, of a journal-box mounted on the axle and comprising two half-boxes provided with means for clamping them about the axle, the inner face of one of said half-boxes being provided with longitudinal grooves near its edges for the reception of a fibrous packing and the inner face of the other half-box being provided with longitudinal serrated ribs arranged to

project into said grooves and engage and hold the packing against displacement, substantially as described.

10 5 The combination with a railway-car axle, of a journal-box mounted on the axle and comprising two half-boxes provided with means for clamping them about the axle, said half-boxes being provided on their adjacent faces with semicylindrical recesses for the re-  
15 ception of a sleeve and at their ends with inwardly-projecting semi-annular flanges inclosing said sleeve, the inner face of one of said boxes being provided with longitudinal grooves for the reception of a fibrous pack-  
20 ing, and the inner face of the other half-box being provided with longitudinal serrated ribs arranged to project into said grooves and engage and hold the packing, and antifric-  
tion-rollers arranged in the box between said flanges, substantially as described.

11. The combination with a railway-car axle, of a journal-box comprising two half-boxes provided with means for clamping them about the axle, said half-boxes being pro-  
25 vided on their opposite ends with continuous

grooves for the reception of fibrous packing, and end caps fitted against the ends of the half-boxes and provided on their inner faces with serrated ribs projecting into said grooves and engaging and holding the packing there-  
30 in, substantially as described.

12. The combination with a railway-car axle, of a journal-box comprising two half-  
35 boxes provided with means for clamping them about the axle, end caps clamped against the ends of the half-boxes, the outer end cap being imperforate and the inner end cap being provided centrally with an aperture for the  
40 reception of the axle, the wall of said aperture being provided with an internal annular groove for the reception of fibrous packing, and transverse ribs formed in the bottom of said groove, substantially as described.

In testimony whereof I have hereunto set my hand in presence of two subscribing wit-  
45 nesses.

EDGAR F. CROWTHER.

Witnesses:

GEO. W. REA,  
C. D. KESLER.