

(No Model.)

H. BLAKE. FEED WATER HEATER.

No. 523,616.

Patented July 24, 1894.

FIG. 1.

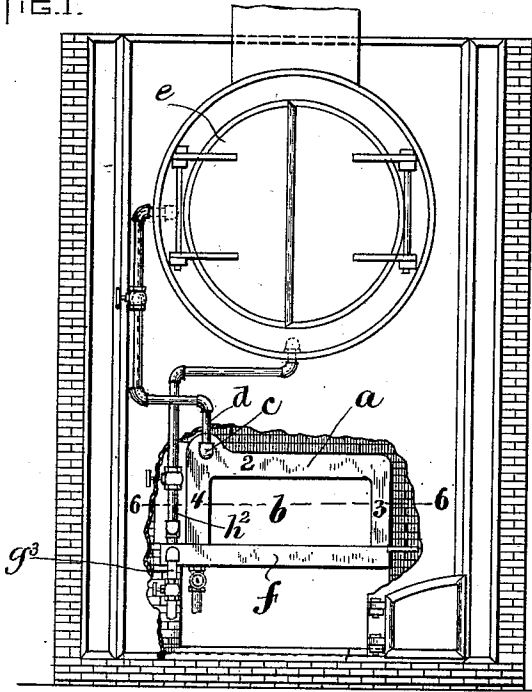

FIG. 2.

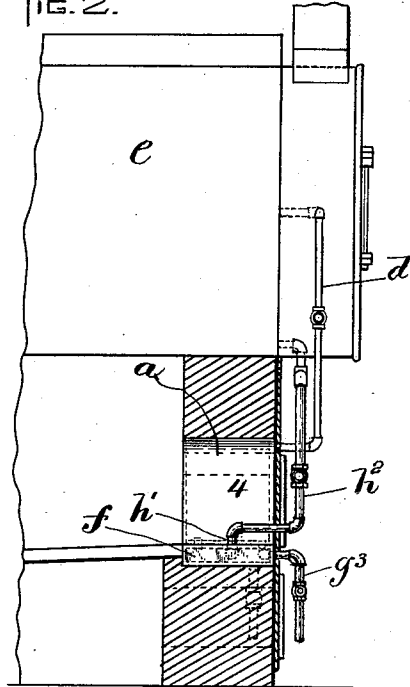

FIG. 3.

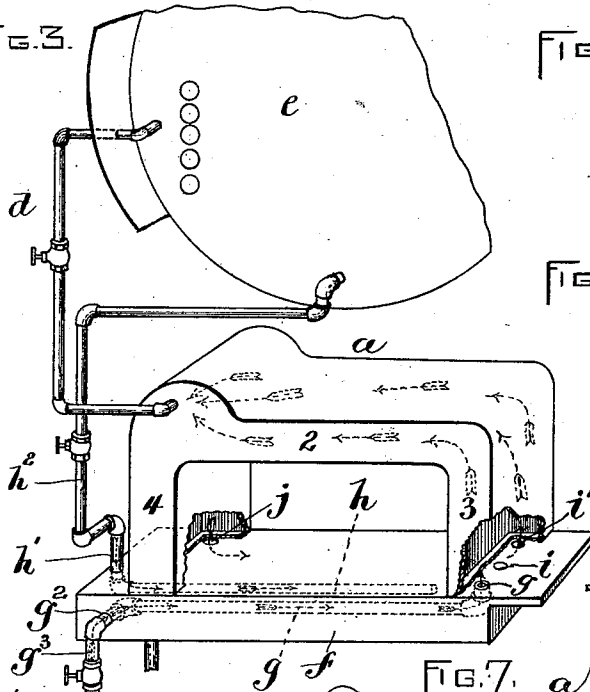

FIG. 4.

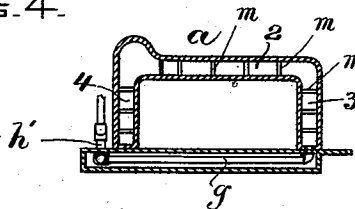

FIG. 5.



FIG. 6.

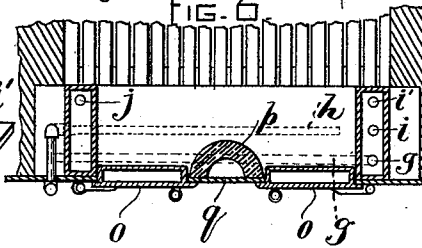
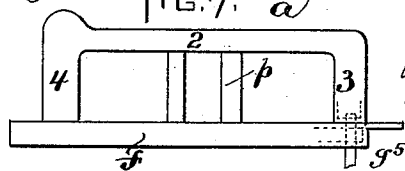

FIG. 7.



WITNESSES:
F. M. Whipple
A. D. Hanson

INVENTOR:
Harry Blake
 by *Might & Broome*
 Atty.

UNITED STATES PATENT OFFICE.

HARRY BLAKE, OF HAVERHILL, ASSIGNOR TO HENRY H. WINCHESTER, OF WESTFIELD, MASSACHUSETTS.

FEED-WATER HEATER.

SPECIFICATION forming part of Letters Patent No. 523,616, dated July 24, 1894.

Application filed September 11, 1893. Serial No. 485,272. (No model.)

To all whom it may concern:

Be it known that I, HARRY BLAKE, of Haverhill, in the county of Essex and State of Massachusetts, have invented certain new and useful Improvements in Feed-Water Heaters, of which the following is a specification.

This invention relates to that class of feed-water heaters employing a hollow furnace-mouth, through which the feed-water passes.

The invention has for its object to provide an improved heater of this class, in which the water shall circulate entirely around the furnace-mouth.

The invention consists in the improvements which I will now proceed to describe and claim.

Of the accompanying drawings, forming part of this specification: Figure 1 represents a front elevation of a boiler and its furnace, provided with my improved heater, a portion of the casing being broken away. Fig. 2 represents a side elevation of the boiler and heater, the casing being shown in section. Fig. 3 represents a perspective view of the heater and a portion of the boiler. Fig. 4 represents a longitudinal section of the heater. Fig. 5 represents a top view of the dead-plate removed. Fig. 6 represents a section on line 6-6 of Fig. 1. Fig. 7 represents a front view of the heater alone.

The same letters and figures of reference indicate the same parts in all the figures.

In the drawings: *a* represents a double-walled casing, which forms the top and two sides of a furnace-mouth *b*, said casing comprising the horizontal top-portion 2, and the vertical legs 3 4 extending downwardly from the top-portion, the whole forming a continuous angular water-space.

The upper portion of the casing *a* is provided with a fitting *c*, of any suitable kind, adapted for connection with a pipe *d*, which communicates with the upper portion of the water-space of a boiler *e*, so that water can pass from the upper portion of the casing into the boiler.

f represents a double-walled dead-plate, which forms the bottom of the furnace-mouth, and is suitably supported in the casing of the furnace. Said dead-plate constitutes a water-chamber and a support for the casing *a*, the

lower ends of the legs 3 4 bearing upon said dead-plate. The dead-plate is provided with two internal conduits *g* and *h*, which extend lengthwise of the dead-plate, from one end nearly to the other end. The conduit *g* is intended for the admission of feed-water from an external source of supply to the leg 3 of the casing *a*, while the conduit *h* is intended to conduct return-water from the boiler to said leg 3. The conduit *g* is connected at its inner end, by an elbow or other fitting *g'*, with the leg 3, and is provided at its outer end with a projecting nipple *g²* or other suitable fitting, whereby it may be connected with a feed-water supply pipe *g³*, the arrangement being such that feed-water from the pipe *g³* will pass through the conduit *g* without mingling with the water in the dead-plate, and will pass directly into the leg 3 of the casing *a*.

The outer end of the return-water conduit *h* is provided with a nipple *h'* or other suitable fitting, whereby it may be connected with a return-water pipe *h²*, which communicates with the lower portion of the water-space of the boiler.

The conduit *h* preferably terminates within the dead-plate *f*, and near the end thereof which is under the leg 3, so that water passing through the said conduit is discharged into the chamber of the dead-plate before entering the leg 3, the upper wall of the dead-plate being provided with an orifice *i*, which is in such proximity to the delivering end of the conduit *h* that water from said conduit will pass upwardly into the leg 3 through the orifice *i*.

It will be seen that the feed-water entering through the pipe *g³* is caused by the conduit *g* to pass directly to the leg 3, and passes upwardly through said leg along the horizontal portion 2 to the pipe *d*, and through said pipe to the boiler, the water being subjected during its passage to the heat within the furnace-mouth. The return-water from the boiler passes through the pipe *h²* and along the conduit *h*, and then upwardly through the orifice *i*, leg 3 and horizontal portion 2 to the pipe *d*, the water from both sources being exposed to heat during its passage along the dead-plate and through the parts 3 and 2 of the casing *a*. The leg 4 of the casing *a* communicates,

through one or more orifices *j*, with the dead-plate; while the leg 3 is connected, as already described, by the orifice *i* with said dead-plate, and also, if desired, by another orifice *i'* (see Figs. 3 and 5). The water passing through the conduit *h*, being discharged into the interior of the dead-plate before passing upwardly through the orifice *i*, induces a current of water in the dead-plate in the same direction, so that there is a constant tendency of water in the leg 4 to flow downwardly into the dead-plate and along the latter toward the orifices *i i'*, said water passing upwardly and flowing through the leg 3 and horizontal portion 2. Hence, by the described arrangement, continual circulation is maintained through all parts of the casing and the dead-plate, the result being a uniform heating of the water and freedom from liability of burning out any part of the furnace-mouth, and the utilization of the heat to the best advantage.

The walls of the casing *a* may be supported by internal stay-bolts *m*, as shown in Fig. 4.

When the furnace-mouth is provided with two doors *o o*, as shown in Fig. 6, the interior front-plate or casing between the said doors may be protected by an arched vertical cross-piece of fire-brick *p*, the form of which is such that, while it protects the front-plate *q*, it permits coal to be supplied freely to the central part of the grate without obstructing said central part. The cross-piece *p*, bearing at its lower end on the dead plate and at its upper end on the horizontal part of the casing *a*, supports said casing and prevents it from sagging.

It will be seen that the protecting brick or piece *p* subdivides the opening surrounded by the casing and dead-plate into two parts, each constituting a doorway. The protecting-piece *p*, located as shown, obviates the necessity of making a hollow wall containing a water-space at the center of the casing, so that the construction is more economical than it would be without a protecting-piece, in which case a hollow wall would be required.

I do not limit myself to the arrangement of the feed-water conduit above described. If desired, said conduit may enter the leg 3 of the casing *a* without passing through the dead-plate, as shown in Fig. 7, in which *g*⁵ represents a feed-water pipe, communicating directly with the lower end of the leg 3 and being entirely exterior to the dead-plate.

I claim—

1. In a feed-water heater, the combination of a double-walled casing forming the top and sides of a furnace-mouth and adapted to be connected at its upper portion with a boiler supply-pipe; and a double-walled dead-plate forming the bottom of said mouth, the said dead-plate having a return-water conduit, communicating at one end with the bottom portion of one of the legs of the casing and with the interior of the dead-plate near one end thereof, said conduit having at its other

end means for connection with a supply-pipe, the arrangement being such that water entering said conduit will pass through the dead-plate from end to end, up one leg of the casing and along the top of the casing to the boiler supply-pipe, both legs of the casing communicating with the dead-plate, so that a continuous circulation is maintained horizontally through the dead-plate in one direction, upwardly through one leg of the casing, horizontally through the top of the casing in the opposite direction, and downwardly through the other leg of the casing, as set forth.

2. In a feed-water heater, the combination of a double-walled casing forming the top and sides of a furnace-mouth and adapted to be connected at its upper portion with a boiler supply-pipe; a double-walled dead-plate forming the bottom of said mouth, the said dead-plate having a return-water conduit communicating at one end with the bottom portion of one of the legs of the casing and with the interior of the dead-plate near one end thereof, said conduit having at its other end means for connection with a supply-pipe, the arrangement being such that water entering said conduit will pass through the dead-plate from end to end, up one leg of the casing and along the top of the casing to the boiler supply-pipe; and a feed-water conduit communicating with one leg of the casing, as described, both legs of the casing communicating with the dead-plate, so that a continuous circulation is maintained horizontally through the dead-plate in one direction, upwardly through one leg of the casing, horizontally through the top of the casing in the opposite direction, and downwardly through the other leg of the casing, as set forth.

3. In a feed-water heater, the combination of a double-walled casing forming the top and sides of a furnace-mouth and adapted to be connected at its upper portion with a boiler supply-pipe; and a double-walled dead-plate forming the bottom of said mouth, the said dead-plate having a feed-water conduit and a return-water conduit, both communicating at one end with the bottom portion of one of the legs of the casing, the return-water conduit communicating also with the interior of the dead-plate near one end thereof, each conduit having at its other end means for connection with a supply-pipe, the arrangement being such that water entering said conduits will pass through the dead-plate from end to end, up one leg of the casing and along the top of the casing to the boiler supply-pipe, both legs of the casing communicating with the dead-plate, so that a continuous circulation is maintained horizontally through the dead-plate in one direction, upwardly through one leg of the casing, horizontally through the top of the casing in the opposite direction, and downwardly through the other leg of the casing, as set forth.

4. The combination of a boiler, a double-walled casing forming the top and sides of

the furnace-mouth, a pipe connecting the upper portion of said casing with the upper portion of the water-space of the boiler, a hollow dead-plate forming the bottom of the furnace-mouth and provided with a longitudinal feed-water conduit and with a longitudinal return-water conduit, each communicating at its inner end with one leg of the casing and one communicating also with the interior of the dead-plate, a feed-water pipe connected with the outer end of the feed-water conduit, and a return-water pipe from the lower portion of the boiler communicating with the outer end of the return-water conduit, both legs of the casing communicating with the dead-plate, as set forth.

5. A feed-waterheater, comprising a double-walled casing and a hollow dead plate, the whole surrounding the furnace-mouth and

provided with a central vertical cross-piece of refractory material bearing at its lower end on the dead plate and at its upper end on the horizontal part of said casing, said cross-piece subdividing the furnace-mouth into two parts, and not only protecting the front-plate between the doors that cover the parts or openings of the furnace-mouth but also supporting the horizontal part of the casing and preventing it from sagging.

In testimony whereof I have signed my name to this specification, in the presence of two subscribing witnesses, this 5th day of September, A. D. 1893.

HARRY BLAKE.

Witnesses:

C. F. BROWN,
A. D. HARRISON.