

1,008,205.

J. SCHIRRA,
VACUUM CLEANING APPARATUS.
APPLICATION FILED MAY 10, 1911.

Patented Nov. 7, 1911.
2 SHEETS—SHEET 1.

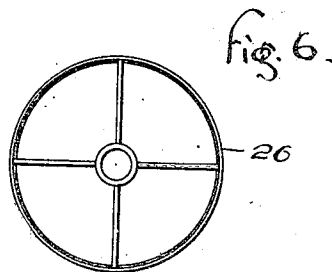
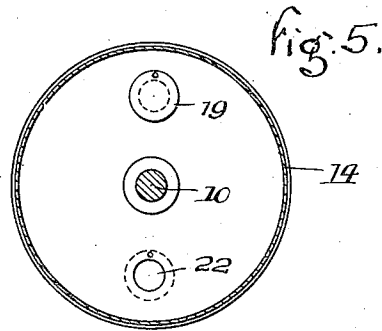
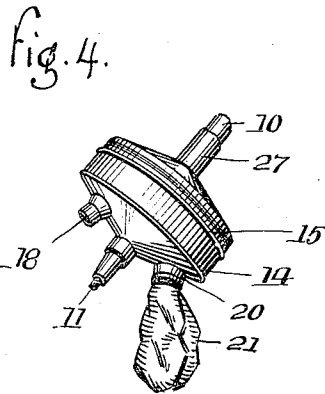
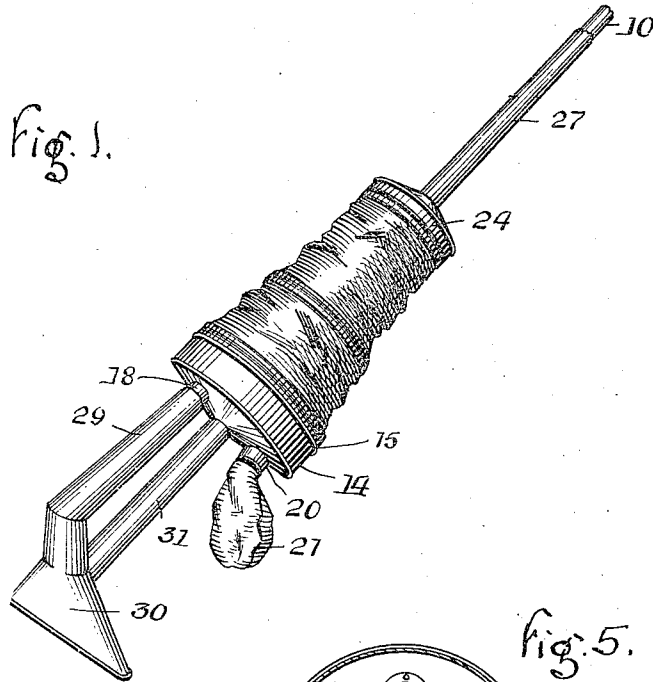

WITNESSES:

Samuel Payne.
H. L. Seitz.

INVENTOR.
Julius Schirra.
BY
A. C. [Signature]
ATTORNEYS.

1,008,205.

J. SCHIRRA.
VACUUM CLEANING APPARATUS.
APPLICATION FILED MAY 10, 1911.

Patented Nov. 7, 1911.

2 SHEETS—SHEET 2.

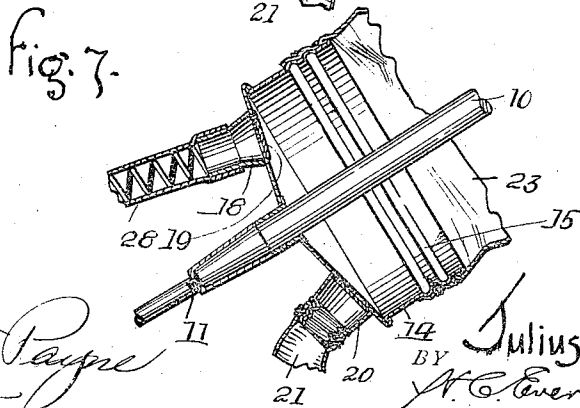
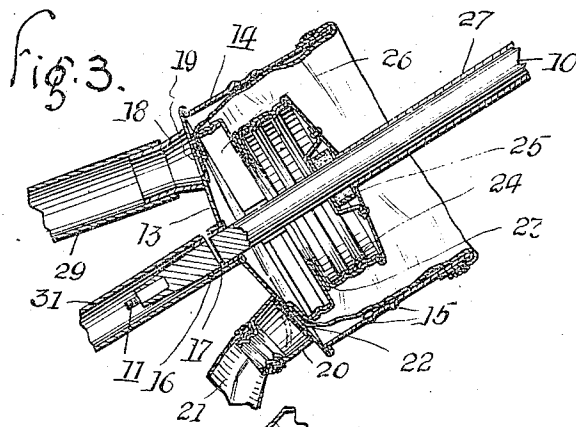
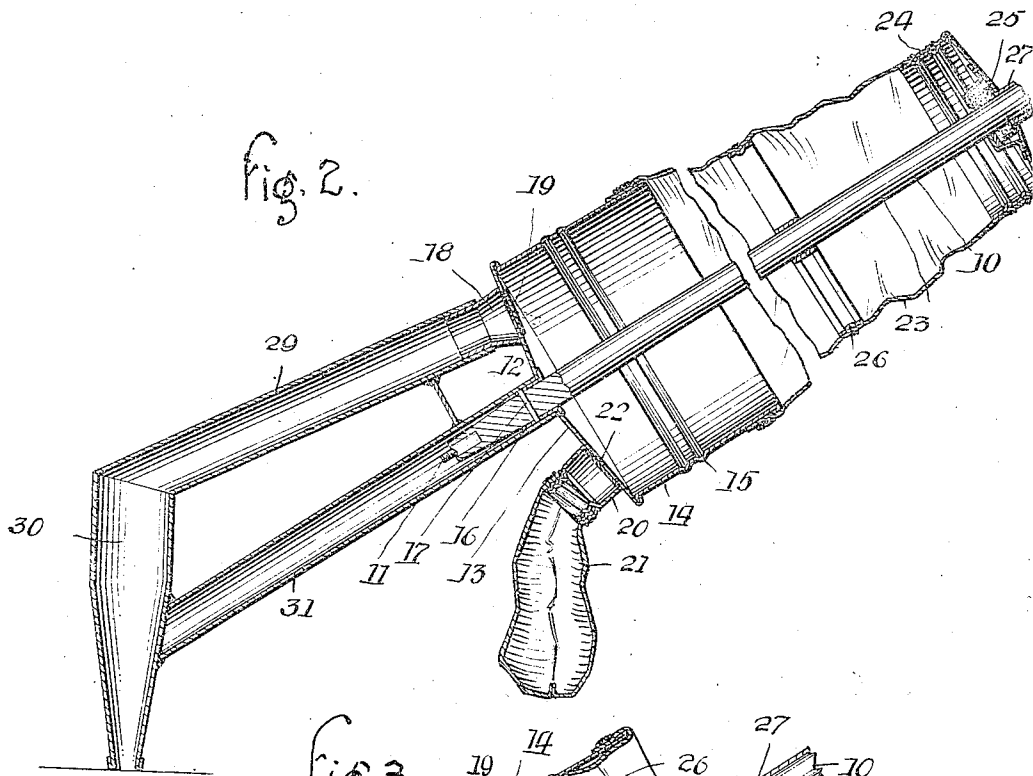

WITNESSES:

Samuel Payne
H. J. Seitz

INVENTOR.
Julius Schirra
BY *W. C. Ewert & Co.*
ATTORNEYS.

UNITED STATES PATENT OFFICE.

JULIUS SCHIRRA, OF PITTSBURGH, PENNSYLVANIA, ASSIGNOR OF ONE-EIGHTH TO HENRY J. THOMAS AND ONE-FOURTH TO GEORGE S. WILSON, BOTH OF PITTSBURGH, PENNSYLVANIA.

VACUUM CLEANING APPARATUS.

1,008,205,

Specification of Letters Patent.

Patented Nov. 7, 1911.

Application filed May 10, 1911. Serial No. 626,274.

To all whom it may concern:

Be it known that I, JULIUS SCHIRRA, a citizen of the United States of America, residing at Pittsburgh, in the county of Allegheny and State of Pennsylvania, have invented certain new and useful Improvements in Vacuum Cleaning Apparatus, of which the following is a specification, reference being had therein to the accompanying drawing.

My invention relates to improvements in vacuum cleaning apparatus and has particular relation to devices for creating the suction employed in such apparatus.

The principal object of my invention is to provide a device of this character adapted for hand manipulation and in which a maximum suction and discharge action is provided with a relatively small flexible device.

A further object of the invention is to provide a device of this character in which the flexible portion of the device is moved into and out of an annular member which carries the inlet and discharge controlling devices, the conformation of the flexible portion being such as to permit the movable end to practically pass within the permanent annulus position at the opposite end when the device is collapsed, to protect the flexible portion against damage.

A further object is to provide a device of this character in which the inlet and discharge openings are positioned "off-center," the device being provided with means whereby it may be removably or permanently secured to a support which is adapted to contact with the surface to be cleaned.

Other and further objects of the invention are to provide a device of this character which is neat and attractive in appearance, durable in construction, simple and efficient in operation, which may be readily attached to the handle of a household utensil, and which can be manufactured at a relatively low cost.

To these and other ends, the nature of which will be readily understood as the invention is hereinafter disclosed, my invention consists in the improved construction and combination of parts, illustrated in the accompanying drawings, and particularly pointed out in the appended claims.

To the accompanying drawings, in which similar reference characters indicate similar parts in each of the views: Figure 1 is a perspective view of a vacuum cleaner apparatus in which my invention forms a part, Fig. 2 is a central longitudinal sectional view of the parts shown in Fig. 1, the bellows being shown in its expanded position, Fig. 3 is a view of a portion of the parts shown in Fig. 2, with the bellows collapsed, Fig. 4 is a perspective view of the parts shown in Fig. 3, Fig. 5 is a cross sectional view taken on the line V-V of Fig. 2, Fig. 6 is a detail view of the intermediate supporting member for the bellows. Fig. 7 is a view of the lower part of the suction device, and showing a different form of connection of the suction head and apparatus carrier.

The suction device shown herein is that employed in connection with the invention disclosed in my companion application filed February 9th, 1911, Serial No. 607,456, in which the device is shown in operative relation to and as a cleaning attachment for a carpet sweeper, Fig. 7 of this application corresponding to the showing presented in said companion application.

Referring more particularly to Fig. 2, the present invention comprises a suction device, a suction head, and a dust collecting device, the suction device and dust collecting device being preferably arranged in permanent combination, while the suction head is detachable, the particular form of head employed being dependent upon the use to which the cleaning apparatus is to be put. For instance, the head shown in Fig. 2 is adapted to be employed for cleaning small spaces, furniture, etc., while the head shown in my companion application heretofore referred to, and a portion of the connections of which is shown in Fig. 7, is adapted to be employed in connection with a carpet sweeper, the inlet to the suction device being arranged relatively to the point of support of such device so as to permit the handle, where the latter is a part of a carpet sweeper, to be employed in connection with either type of suction head.

The handle, indicated at 10 and which forms the support for the suction device, is preferably provided at its forward end with means for attaching it to the cross brace

of a carpet sweeper (not shown), the means disclosed being the threaded projecting portion 11.

The suction device, preferably in the form of a bellows collapsible axially is permanently secured adjacent to the forward end of the handle by means of an end cap 12, this cap being in the form of a plate 13 preferably slightly dish-shaped and of circular contour, said plate being provided with a cylindrical annulus 14 secured to the plate in any preferred manner and which projects rearwardly from the plate a suitable distance, and forming the support for the forward end of the flexible bellows structure, the annulus being preferably provided with circumferential beads 15. The plate 13 is provided approximate its center with an opening and a forwardly extending cylindrical projection 16 adapted to fit over the forward end of the handle 10 and fixedly connected to the handle by suitable means such as a pin 17. Said plate is also provided with an inlet in the form of a cylindrical projection 18 which is adapted to receive the connection from the suction head, this inlet being arranged off-center, the port being controlled by a valve 19, preferably a flap valve mounted on the inner face of the plate and adapted to close the port when the bellows is moved in one direction. Said plate is further provided with a projection 20 having its forward end provided with a configuration complementary to that carried by the open end of a dust collector 21, preferably in the form of a bag, the connection shown being by a screw threaded connection. The outlet port provided by the projection 20, is adapted to be closed by a valve 22, preferably mounted on the outer face of the plate, but which may be obviously positioned at any point within the passageway formed by the projection 20.

23 designates the flexible portion of the suction device which may be of any suitable material, and is preferably circular and tapered from its forward end toward its rear end, as best shown in Fig. 2, the rear end being secured to an annular collar 24 having a configuration somewhat similar to that of the end cap 12 but mounted to slide freely longitudinally of the handle, the annulus facing the annulus 14, said collar, however, being of less diameter than the end cap 12. Inasmuch as the collar is adapted to be freely moved on the handle, I preferably provide a suitable packing within the collar and surrounding the handle, said packing being indicated conveniently at 25 being supported by the part of the collar and movable with the collar longitudinally of the handle, this packing being employed for the purpose of preventing material leakage of air from the bellows when the latter is being collapsed. Substantially midway of the length of the

flexible portion 23, I secure a spider 26, said spider having a central collar-like portion adapted to freely slide on the handle.

The collar 24 is provided with a sleeve 27 which extends rearwardly on the handle a suitable distance, and which serves as a member to be grasped by the operator when the cleaning apparatus is to be used.

By reason of the particular structure and arrangement of parts above described, it will be readily seen that when the suction device is in the position shown in Fig. 2, in which the flexible portion or bellows 23 is shown as expanded, the collar will be positioned at its maximum distance from the end cap 12, the bellows having its folds practically straightened out; this position is assumed at the end of the suction operation, the movement of the collar to this position providing the necessary suction for carrying the dust and dirt into the interior of the suction device and by reason of the metallic annulus 14 located at the point of inlet to this device, the heavier particles will not be liable to be carried into the flexible portion to any material extent, so that if the bellows is collapsed with the necessary formation of folds therein, these heavy particles will not be in position to materially affect the material of the flexible portion. A movement of the collar 24 toward the end cap 12 by the use of the sleeve 27, will cause the flexible portion to gradually form in folds on opposite sides of the spider 26, and will gradually be moved into the space within the annulus to the position shown in Fig. 3, the spider 26 practically passing in close proximity to the inner face of the plate 13, with that portion of the bellows between the spider and the end cap practically reversed, the whole giving the appearance of being turned inside out, the parts, however, being so positioned that the collar 24 lies entirely within the space formed by the annulus 14, practically carrying all of the flexible portion within the end cap. This movement of the bellows has closed the valve 19 and opened the valve 22, thereby carrying the material taken up through the suction head into the dust collecting bag or pocket. When the movement of the collar 24 is again reversed to expand the bellows, that portion of the bellows in rear of the spider 26 first expands until the spider is drawn out of the end cap the forward portion of the bellows being gradually drawn out after the spider has left its position within such cap. This particular construction provides for a maximum suction effect with a minimum length in the flexible portion of the suction device, the fact that the collar 24 passes entirely within the end cap, providing an additional length of movement of the parts in creating the suction while the parts are still within the end cap. Further-

more the suction device need not be of excessive area in cross section, the particular tapered shape of the bellows with the ability to collapse to a position such as shown in Fig. 3, rendering a relatively large cross sectional area unnecessary.

As heretofore pointed out, the suction device just described is that disclosed in my companion application above referred to, and this construction permits of the employment of different types of suction heads. The type shown in my companion application is that including a flexible connection 28 which is simply slipped over the projection 18, as shown in Fig. 7, the carpet sweeper or other support for the attachment and to which the handle is firmly secured, providing the necessary stability to the parts, the suction head being carried by the body of the carpet sweeper.

The construction of the suction head shown in the present drawings differs from that disclosed in Fig. 7, in that the connection for the head is not flexible, being in the form of a tubular member 29 to the forward end of which the suction head 30 is secured, the head having the member 31 positioned to axially align with the handle and adapted to extend over the projection 16 and acting as a continuation of the handle to support the suction head. By this construction it will be readily seen that the suction device is applicable for use either with a flexible or non-flexible connection with the suction head, the particular location of the inlet being such as to permit of an interchangeability of the several types of heads and still provide the actual support by the forward end of the handle 10.

The particular ability to place the parts in the collapsed position shown and the relatively small size of the suction device with its maximum suction effect are positive advantages resulting from the construction shown; in addition, specific advantages have heretofore been pointed out.

While I have herein shown and disclosed one way in which my invention may be carried into effect, I am aware that changes and modifications therein may be necessary to meet the various exigencies of use, and I reserve the right to make any and all such changes and modifications as may be found necessary in so far as they may fall within the spirit and scope of the invention as hereinafter pointed out in the claims.

Having thus described my invention, what I claim as new is:—

1. In vacuum cleaning apparatus, a suction device and a support, said device having its forward end substantially-rigid and permanently secured to the support, and also having its other end movable longitudinally of the support, said end portions having a flexible connection, said movable end and

flexible connection, when the device is collapsed, being housed within the forward end portion.

2. In vacuum cleaning apparatus, a suction device and a support, said support extending axially of said device, said device having its forward end substantially-rigid and permanently secured to the support, and also having its other end movable longitudinally of the support, said end portions having a flexible connection, said movable end and flexible connection, when the device is collapsed, being housed within the forward end portion.

3. In vacuum cleaning apparatus, a suction device and a support, said support extending axially of and through said device, said device having its forward end substantially-rigid and permanently secured to the support, and also having its other end movable longitudinally of the support, said end portions having a flexible connection, said movable end and flexible connection, when the device is collapsed, being housed within the forward end portion.

4. In vacuum cleaning apparatus, a suction device and a support, said support extending axially of said device, said device having a substantially-rigid cup-shaped forward end permanently secured to the support, a flexible member secured to the face of the wall of said forward end, and a substantially-rigid end mounted to slide longitudinally of said support to which the other end of said flexible connection is connected, said movable end and flexible connection being housed within the cup-shaped end when the device is collapsed.

5. In vacuum cleaning apparatus, a suction device and a support, said support extending axially of said device, said device having a substantially-rigid cup-shaped forward end permanently secured to the support, a flexible member secured to the face of the wall of said forward end, and a substantially-rigid end mounted to slide longitudinally of said support to which the other end of said flexible connection is connected, a supporting device secured to said flexible connection within and intermediate the ends of said connection, said movable end, the flexible connection and said supporting device, being housed within the cup-shaped end when the suction device is collapsed.

6. In vacuum cleaning apparatus, a suction device and a support, said support extending axially of said device, said device having its forward end secured to the support, said end carrying inlet and outlet ports, said inlet port being positioned off-center.

7. In vacuum cleaning apparatus, a suction device and a support, said support extending axially of said device and projecting forwardly beyond the forward end of said device and adapted to connect the device to

a cleaning attachment, said forward end having a projection providing the inlet port for the device, said port being valve-controlled, said projection being located off-center.

8. A suction device adapted to vacuum cleaning apparatus comprising substantially-rigid end portions and a flexible connection therebetween, and a support extending axially of the end portions, the forward end portion being approximately cup-shaped and permanently secured to the support, the opposite end portion being freely movable longitudinally of the support to collapse the device, said movable end portion carrying a packing within the interior of the device and adapted to substantially close said movable end against leakage.

9. A suction device adapted for vacuum cleaning apparatus comprising substantially-

rigid end portions and a flexible connection therebetween, and said support extending through said end portions, the forward end portion being approximately cup-shaped and of larger diameter than the other end portion, and being permanently secured to said support, said opposite end portion being movable longitudinally of the support, said flexible connection being substantially tapered from the forward to the movable end portion, said connection and the movable end portion being housed within the cup-shaped end portion when the device is collapsed.

In testimony whereof I affix my signature in the presence of two witnesses.

JULIUS SCHIRRA.

Witnesses:

MAX H. SROLOVITZ,
H. G. SMITZ.