

(19) **DANMARK**

(10) **DK/EP 3003961 T3**



(12) **Oversættelse af
europæisk patentskrift**

Patent- og
Varemærkestyrelsen

-
- (51) Int.Cl.: **B 67 D 1/04 (2006.01)** **B 67 D 1/08 (2006.01)**
- (45) Oversættelsen bekendtgjort den: **2020-03-09**
- (80) Dato for Den Europæiske Patentmyndigheds bekendtgørelse om meddelelse af patentet: **2019-12-04**
- (86) Europæisk ansøgning nr.: **14738602.3**
- (86) Europæisk indleveringsdag: **2014-05-27**
- (87) Den europæiske ansøgnings publiceringsdag: **2016-04-13**
- (86) International ansøgning nr.: **IB2014061739**
- (87) Internationalt publikationsnr.: **WO2014191908**
- (30) Prioritet: **2013-05-28 IT FI20130124**
- (84) Designerede stater: **AL AT BE BG CH CY CZ DE DK EE ES FI FR GB GR HR HU IE IS IT LI LT LU LV MC MK MT NL NO PL PT RO RS SE SI SK SM TR**
- (73) Patenthaver: **Enomatic S.R.L., Via di Meleto, 1 - Int.27 , Strada in Chianti, 50022 Greve in Chianti FI, Italien**
- (72) Opfinder: **BENCISTA' FALORNI, Lorenzo, Viale Rosa Libri 42, 50022 Greve In Chianti, Italien**
BENCISTA' FALORNI, Gianni, Uzzano 16A, 50022 Greve In Chianti, Italien
- (74) Fuldmægtig i Danmark: **Zacco Denmark A/S, Arne Jacobsens Allé 15, 2300 København S, Danmark**
- (54) Benævnelse: **Automatisk centreringssystem til flasker og beholdere til drikkeafgivelsesindretninger**
- (56) Fremdragne publikationer:
EP-A1- 1 642 863
DE-U1- 9 300 928
FR-A1- 2 920 021
GB-A- 2 089 322
US-A1- 2011 000 250

DESCRIPTION

Field of the invention

[0001] The present invention relates to the field of automatic beverage dispensing devices and apparatuses. In particular, it relates to the field of devices for positioning bottles and similar vessels in said automatic beverage dispensing devices and apparatuses.

State of the art

[0002] Devices and apparatuses are known from the state of the art which are adapted to automatically dispense beverages from containers such as bottles and the like. Some of these devices and apparatuses are such that the bottles or the similar vessels are kept in upside down position and dispense the beverage contained therein by means of conveniently opening a valve which allows the falling by gravity of the beverage into a container conveniently positioned at the mouth of the vessel.

[0003] Others provide the bottles, or the similar vessels, to be kept in vertical position, resting on the bottom thereof, and dispensing the beverage by means of two tubes introduced into the bottle through the bottle cap. An inert gas is blown into the bottle through one of the aforesaid tubes thus keeping the beverage pressurized. An example of apparatus of this kind is disclosed in the German utility model application n. DE9300928U1. When the dispensing tap associated with a tube is opened, the pressurized gas allows dispensing the beverage through the other tube. Devices and apparatuses of this second type are particularly suitable in all those cases, such as e.g. in the case of wine, in which the beverage contained in the bottle would suffer a decline of its organoleptic quality due to the upside down position of the bottle.

[0004] Said devices and apparatuses adapted to automatically dispense beverages from containers such as bottles and the like generally comprise a container adapted to contain the bottles and vessels from which the liquid can be drawn, said container being provided with a resting base, preferably placed on the lower side of the container and associated with mobile lifting means possibly provided with manually, mechanically, electrically or pneumatically activated actuators, and a tap block, adapted to engage the opening of a bottle or similar vessel for beverages and to adjust the release of the beverage contained therein.

[0005] The implementation of these apparatuses provides inserting various bottles into said container according to the following methods: the bottles are first placed on said resting bases, then the resting bases are height adjusted so as to reach the aforesaid tap block and to engage the bottle mouth, thus exerting a pressure which may also be significant, given that the gas tightness is to be maintained. This bottle insertion step is to be followed carefully by an operator because it is essential for the bottle mouth to engage the tap block properly so as to

ensure the tightness with respect to the inert gas blown into the bottle for adjusting the dispensing of the beverage. Therefore, the operator must carefully check the proper positioning of the bottle and correct any incorrect positions which could jeopardize the proper operation of the entire dispensing apparatus. It is therefore necessary for the operator to be present, to be a skilled one and to pay careful attention to the operations described above.

[0006] The present invention allows to overcome the drawback described above by introducing automatic centering means for bottles and vessels in beverage dispensing apparatuses, such as to allow the proper insertion into and the proper positioning of the bottle in said apparatuses also when the operator is unskilled or does not apply the required care in the step of inserting the bottle into said automatic beverage dispensing apparatus.

[0007] The automatic centering means according to the present invention also allow, advantageously, easy installation on existing dispensing apparatuses so as to allow the retrofitting thereof.

Brief description of the drawings

[0008]

Fig. 1 shows a block diagram of an automatic beverage dispensing apparatus belonging to the state of the art, as it is disclosed in WO 2012/000977.

Figures 2 and 3 show the upper part of the resting base for bottles placed in apparatuses for automatically dispensing beverages according to the present invention.

Figures 4 and 5 show the beak seal according to the present invention, for the tap block of apparatuses for automatically dispensing beverages from bottles and similar containers.

Fig. 6 shows a bottle inserted in an automatic beverage dispensing apparatus, provided with an automatic centering system according to the present invention.

Summary of the invention

[0009] An automatic beverage dispensing apparatus comprising automatic centering means for bottles and vessels in beverage dispensing apparatuses, such as to allow the proper insertion into and the proper positioning of the bottle in said apparatuses also when the operator is unskilled or does not apply the required care in the step of inserting the bottle into said automatic beverage dispensing apparatus. Advantageously, the automatic centering means according to the present invention can also be easily installed on existing dispensing apparatuses so as to allow the retrofitting thereof.

Detailed description of the invention

[0010] In reference to accompanying figure 1, the automatic beverage dispensing apparatus according to the present invention comprises a container 10, adapted to contain the bottles and vessels from which the liquid can be drawn, said first container being provided with at least one resting base 17 for said bottles, preferably placed on the lower side of said container; dispensing means adapted to allow the liquid to be drawn from said bottles and vessels, preferably by means of blowing inert gas and comprising a tap block 16, adapted to engage the opening of a bottle or similar vessel for beverages and to adjust the release of the beverage contained therein; possible thermal conditioning means 11 of said container 10, adapted to keep the temperature at a controlled value; control and driving means 12 associated with said dispensing means, with said thermal conditioning means 11 and with means 13 for controlling and managing the performed dispensing operation comprising in turn user interface means 14; supply means 15 adapted to supply, when required, voltage and electric operating current to the various components of the device according to the present invention.

[0011] Said tap block 16 may be advantageously made as described in European Patent EP1352873 and in international Patent Application WO2012000978 by the same applicant of the present patent application.

[0012] Said at least one resting base 17 may be possibly associated with mobile lifting means provided with manually, mechanically, electrically or pneumatically operated actuators associated with said control and driving means 12, or may be associated with resistant elastic means adapted to oppose a thrust such as to lower said resting base 17 and accordingly to push upwards the bottle placed on said resting base 17, thus exerting a pressure thereon such as to lower it.

[0013] Said means 13 for controlling and managing the performed dispensing operation from said device may be further adapted to: collect all the operating data of the device according to the present invention, to adjust said operation thereof according to the current settings and to communicate information to the user concerning the operation and any alarm conditions through the user interface means 14.

[0014] Said at least one resting base 17 also advantageously comprises an upper part 18 having a convex surface adapted to engage the concave bottom of a bottle so as to allow said bottle to move, on said convex surface, in all directions. To this end, the finishing of said convex surface will be such as to minimize the sliding friction thereon.

[0015] Said upper part 18 may also be advantageously made by means of a cap provided with suitable fastening means by means of which it may be fixed to the upper, flat part of said resting base 17.

[0016] In a preferred embodiment of the present invention, said convex surface is made so as to be shaped as a spherical cap, as shown in accompanying figure 2.

[0017] Said tap block 16 also advantageously comprises a beak seal 19 comprising a convex surface, preferably shaped as a spherical cap, and adapted to engage the bottle mouth so as to ensure gas tightness and allow the mouth of said bottle to move on the convex surface of said beak seal 19. To this end, the finishing of said convex surface will be such as to minimize the sliding friction thereon. In fact, this is the very difference between the beak seal of the present invention and the sealing element 24 as disclosed in US 2 324 793, which also has a convex sealing surface. This should provide a pressure tight seal for gas and liquid. However, due to the high filling pressures that are used in a filling plant, any sliding between the mouth of the bottle and that sealing element must be prohibited in order to prevent that the bottle cracks.

[0018] Thus, the present invention allows to simplify the step of inserting the bottle into an automatic beverage dispensing apparatus because the curved surfaces of said beak seal 19 and of the upper part 18 of said resting base 17 allow degrees of freedom to be gained in positioning the bottle, which may engage tightly with said beak seal 19, also when it is slightly tilted with respect to the vertical. The combined action of the curved surfaces of said beak seal 19 and of the upper part 18 of said resting base 17 indeed allows inserting the bottle, "centering" the bottle with respect to the beak of the dispensing cap and subsequently implementing the automatic dispensing machine immediately and in such a manner as to automatically correct any imprecisions or inaccuracies in the positioning of the bottle.

[0019] Furthermore, the use of said beak seal 19 advantageously allows the values to be decreased of the pressure that is to be exerted on said resting bases of the bottles so that the aforesaid tap block can gas-tightly engage the bottle mouth. Indeed, by having a curved profile, said beak seal 19 has a contact area with the bottle mouth characterized by a minimum, usually flat, surface with respect to the surface of the contact area of the current tap blocks. Since the contact surface is smaller, the force exerted by said resting bases to reach the sufficient pressure value to ensure gas tightness may be less, with obvious benefits in terms of dimensioning of the actuators of said mobile lifting means of said resting bases.

REFERENCES CITED IN THE DESCRIPTION

This list of references cited by the applicant is for the reader's convenience only. It does not form part of the European patent document. Even though great care has been taken in compiling the references, errors or omissions cannot be excluded and the EPO disclaims all liability in this regard.

Patent documents cited in the description

- DE9300928U1 [0003]
- WO2012000977A [0008]
- EP1352873A [0011]
- WO2012000978A [0011]
- US2324793A [0017]

Patentkrav

5 1. Indretning til automatisk dispensering af drikke, omfattende en container (10), der er indrettet til at indeholde de flasker og beholdere, fra hvilket væsken kan tappes, hvor den første container (10) er forsynet med mindst én hvilebase (17) for flaskerne, der er placeret på den nedre side af containeren; afgivelsesmidler, der er indrettet til at gøre det muligt at tappe væsken fra flaskerne og beholderne og omfatter en tappeklods (16), der er indrettet til at gå i indgreb med åbningen af en flaske eller lignende beholder til drikke til at justere frigivelsen af en drik, der indeholdes deri; styre- og drivmidler (12), der er forbundet med afgivelsesmidlerne og med kontrol- og styremidler (13) til den udførte afgivelsesfunktion, hvor indretningen yderligere omfatter brugergrænseflademedler (14), **kendetegnet ved, at** den mindst én hvilebase (17) omfatter en øvre del (18) som har en første konveks flade, der er indrettet til at gå i indgreb med den konkave bund af en flaske for at gøre det muligt for flasken at bevæge sig på den første konvekse flade i alle retninger, og **ved, at** tappeklodsen (16) omfatter en bægerforsegling (19), som omfatter en anden konveks flade, der er indrettet til at gå indgreb med flaskemunden for at sikre gastæthed og gøre det muligt for flaskens mund at bevæge sig på den konvekse flade af bægerforseglingen (19), hvor den anden konvekse flade har et færdiggørelseslag til 20 minimering af glidefriktionen.

25 2. indretning ifølge krav 1, hvor den øvre del (18) omfatter en kappe, der er forsynet med passende fastgørelsesmidler, ved hjælp af hvilke den kan fastgøres til den øvre del af hvilebasen (17).

30 3. Indretning ifølge krav 1 - 2, hvor den konvekse flade af den øvre del (18) af den mindst én hvilebase (17) og af bægerforseglingen (19) er formet som en sfærisk kappe.

4. Indretning ifølge krav 1 - 3, hvor færdiggørelseslaget af den konvekse flade af den øvre del (18) af den mindst én hvilebase (17) og af bægerforseglingen

(19) er udformet til at minimere glidefriktionen derpå.

5. Kit til eftermontering af en indretning til automatisk dispensering af drikke ifølge et hvilket som helst af kravene 1-4, omfattende en kappe, der er forsynet med passende fastgørelsesmidler af den øvre del af hvilebasen (17) til flasker af indretningen, og en bægerforsegling (19), der er forsynet med passende fastgørelsesmidler af tapklødsen (16) af indretningen.

DRAWINGS

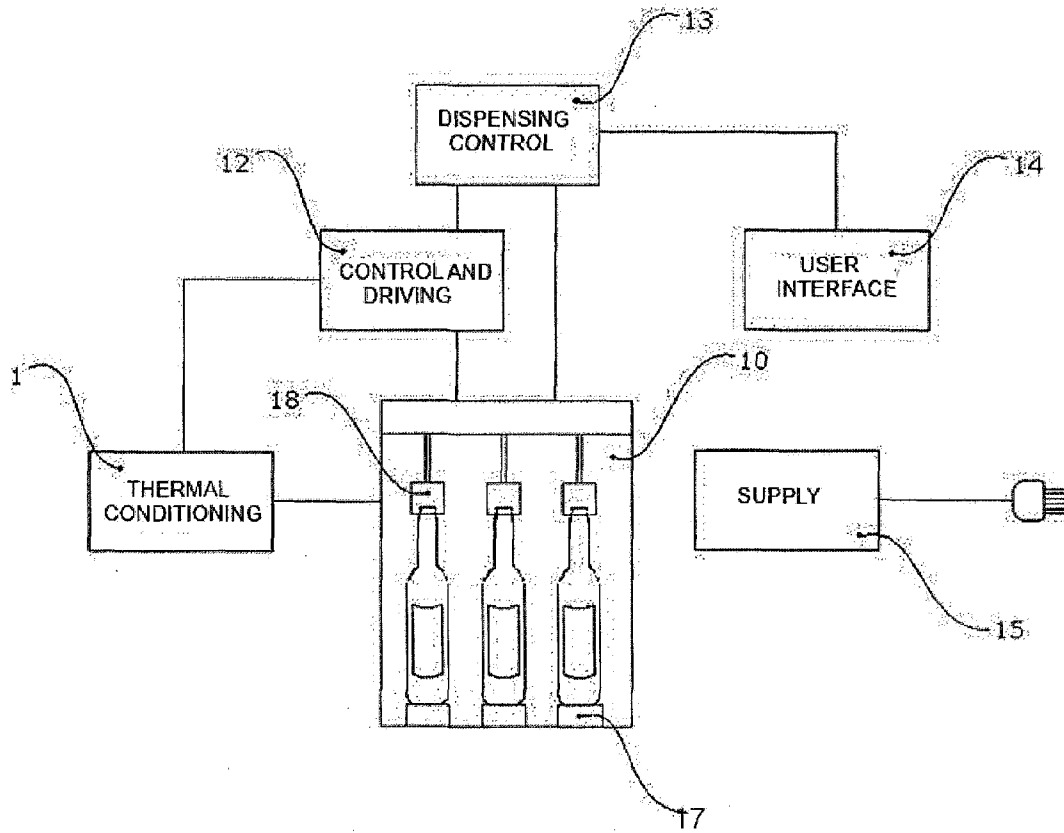

Fig. 1

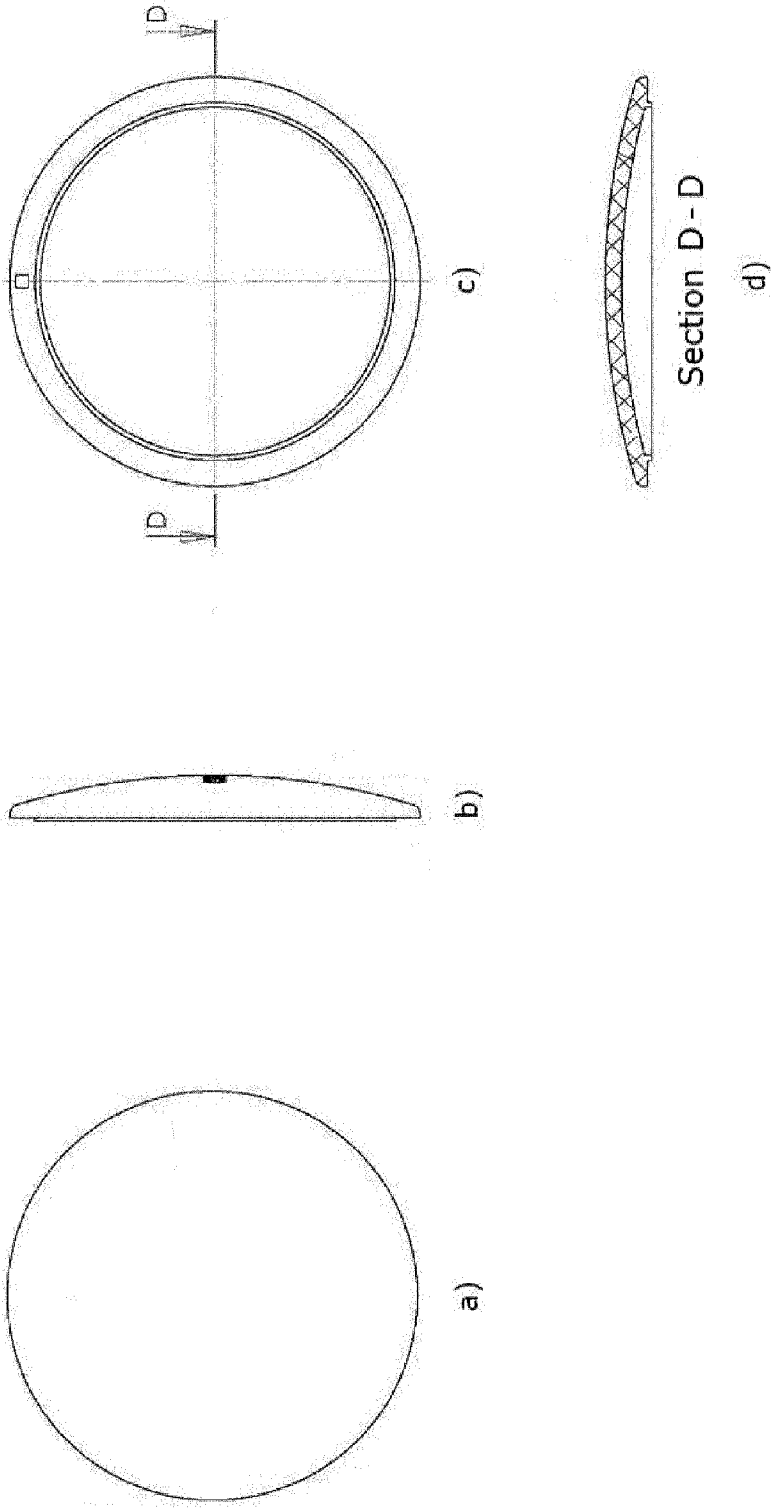

Fig. 2

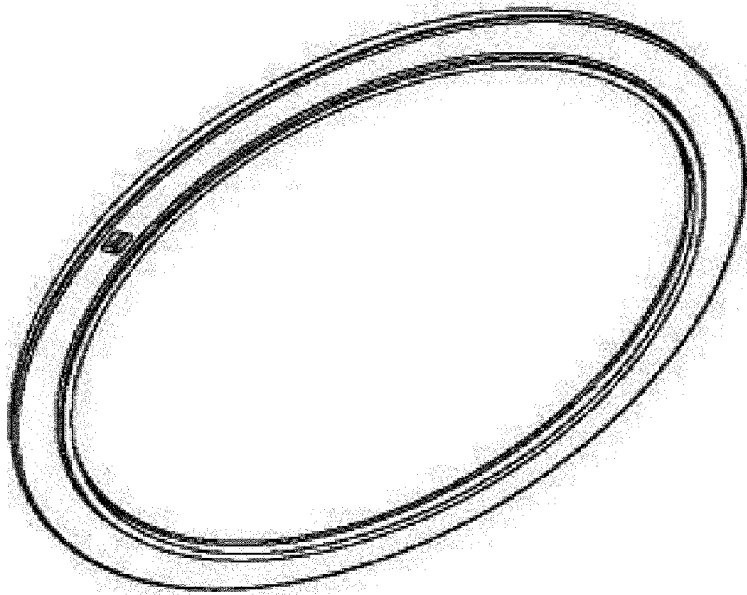
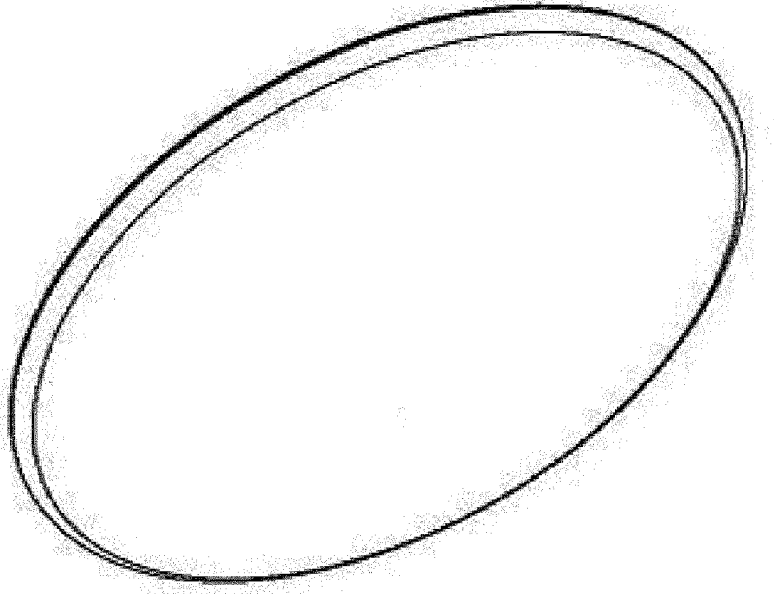

FIG. 3

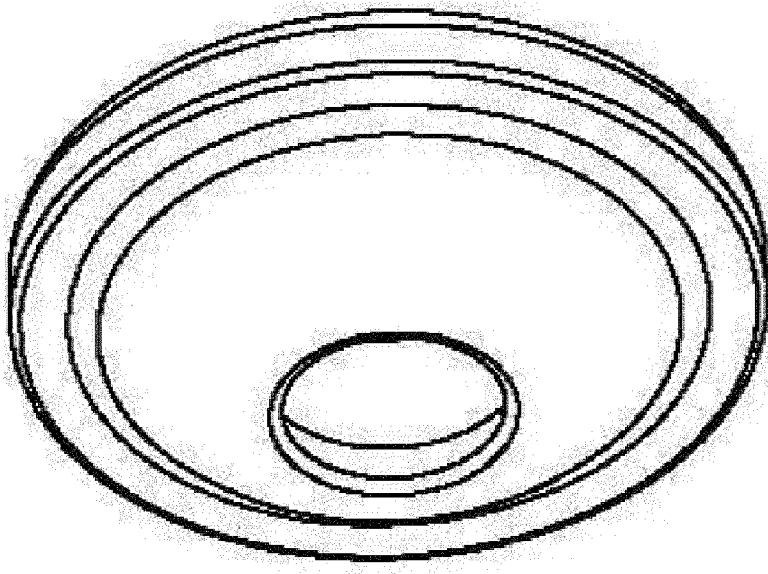
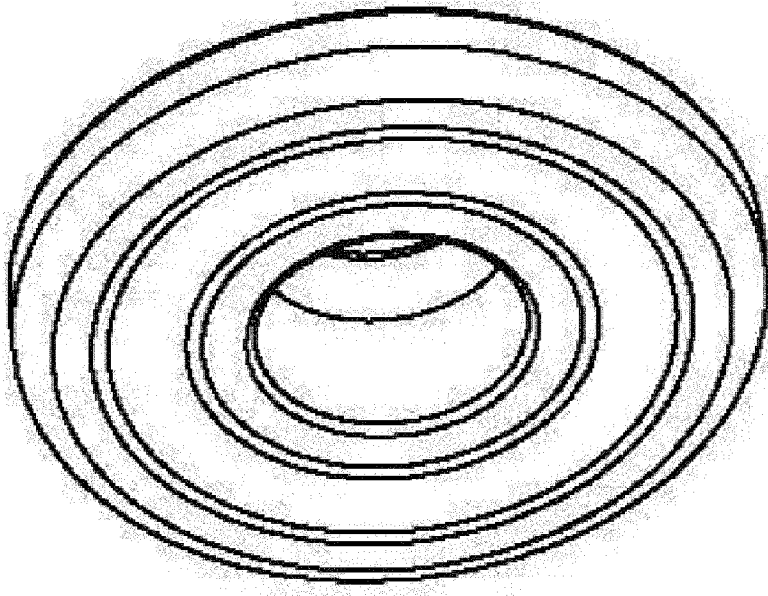

Fig. 5

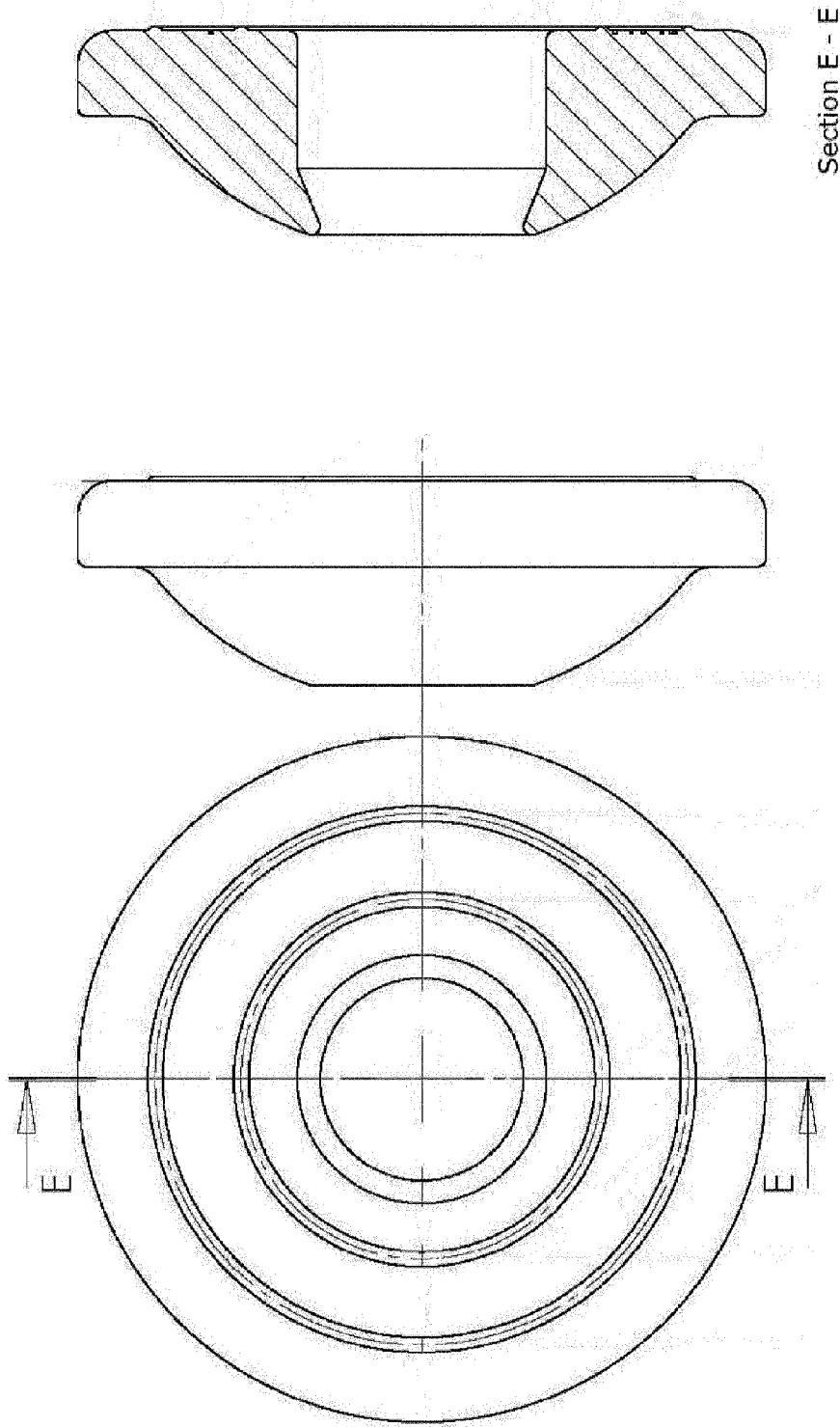

Fig. 4



Fig. 6