

J. J. LAHAYE.  
CAR-COUPLING.

No. 176,647.

Patented April 25, 1876.

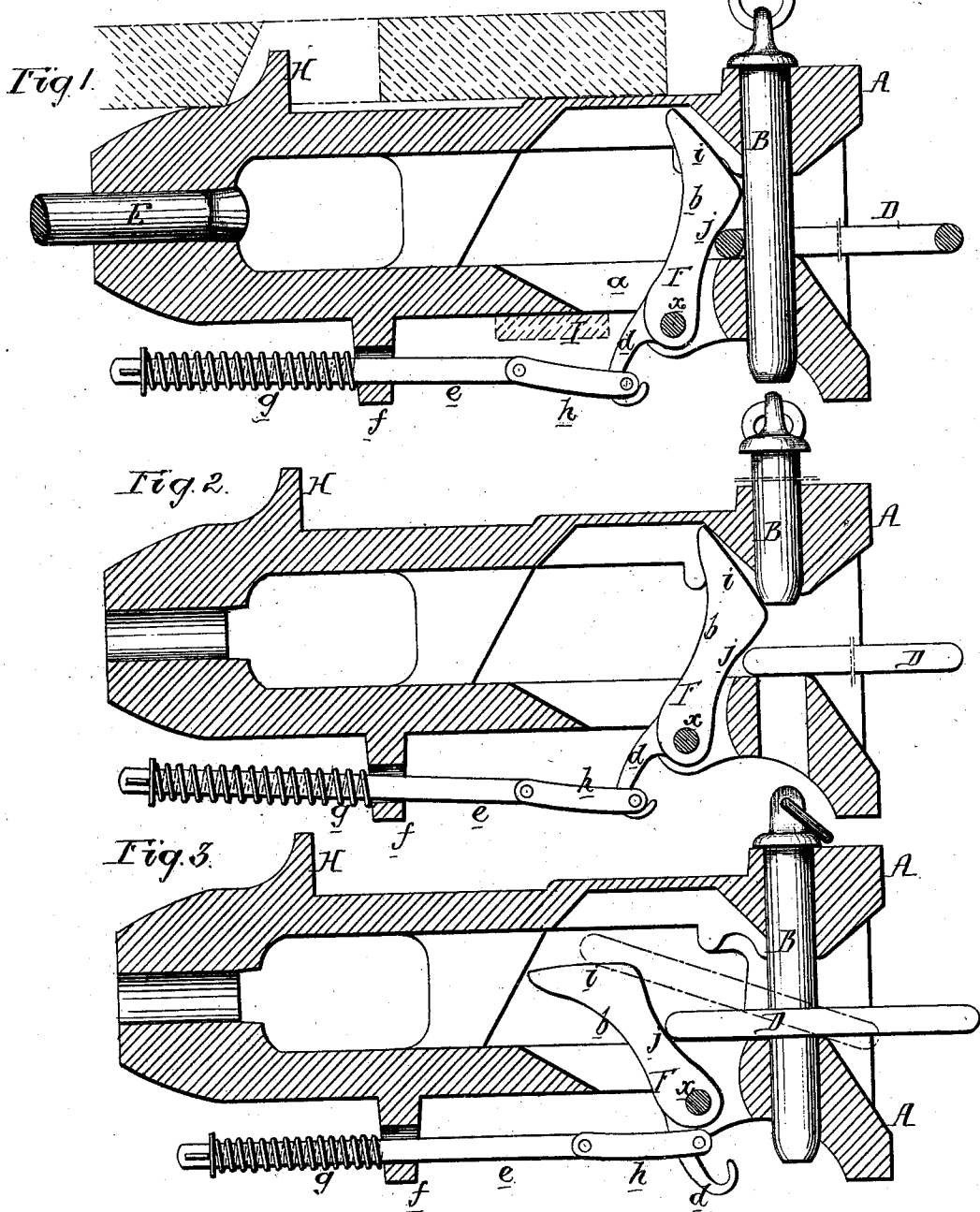

Witnesses  
Harry Howson  
Harry Smith

John J. Lahaye  
by his Attorneys  
Howson and Son

# UNITED STATES PATENT OFFICE.

JOHN J. LAHAYE, OF READING, PENNSYLVANIA.

## IMPROVEMENT IN CAR-COUPINGS.

Specification forming part of Letters Patent No. 176,647, dated April 25, 1876; application filed March 27, 1876.

To all whom it may concern:

Be it known that I, JOHN J. LAHAYE, of Reading, Pennsylvania, have invented certain Improvements in Car-Couplings, of which the following is a specification:

The objects of my invention are, first, to so construct a car-coupling as to prevent the displacement of a coupling-head when the retaining-bolt breaks; second, to prevent the breaking or bending of the coupling-pin; and, third, to facilitate the proper operation of the coupling-link. These objects I attain in the manner which I will now proceed to describe, reference being had to the accompanying drawing, in which—

Figures 1, 2, and 3 are vertical sections of my improved car-coupling, with the working parts in different positions.

A represents the coupling-head; B, the coupling-pin; D, the link, and E the spring-bolt by which the coupling-head is secured to the frame of the car.

In an opening, *a*, in the bottom of the coupling-head, near the front end of the same, is hinged a lever, F, the long arm *b* of which projects upward into the main opening of the head, and forms the yielding dog for supporting the coupling-pin, the short arm *d* of the lever extending downward, and being connected to the end of a rod, *e*, which passes freely through an opening in a lug, *f*, on the under side of the head, and is so acted upon by a spring, *g*, that the latter tends to maintain the lever F in the position shown in Fig. 2. The end of the rod *e* may be connected directly to the arm *d* of the lever; but I prefer to effect the connection as shown in Figs. 1, 2, and 3—that is, by means of a link, *h*—the end of the arm *d*, in this case, being hooked to prevent the displacement of the link.

The top of the coupling-head A is furnished with a lug, H, which extends into an opening in the framing of the car, as shown by dotted lines in Fig. 1, and serves to prevent the detaching of the coupling-head in the event of the breaking of the retaining-bolt E, a yoke, I, which extends under the coupling-

head, serving to support the same, and insuring the retention of the projection H in the opening of the frame.

The upper portion of the yielding dog or arm *b* is of peculiar shape, having an inclination, *i*, on which the lower end of the coupling-pin B bears when the latter is in an elevated position, and also having in front a face, *j*, inclined or curved in the opposite direction, and bearing on the link, so as to retain the same in a horizontal position.

The inclination *i* is such that a downward pressure on the pin will have the effect of moving the lever back far enough to allow the full descent of the said pin, thereby preventing the bending or fracture of the latter, which is likely to occur when it is supported in such a manner that it cannot yield vertically.

The operation of the above-described coupling is as follows: The link D, on entering the coupling-head as shown in Fig. 2, first moves the lever F backward sufficiently to permit the descent of the coupling-pin. When in this position the spring *g* is compressed to such an extent that it causes the inclination *j* of the arm or dog F to bear on the inner end of the link with force sufficient to maintain it in a horizontal position, in order that it may enter into the coupling-head of the adjoining car.

The ordinary backward and forward movements of the link—that is, those caused by the motion of the coupled cars—are sufficient to effect a slight movement only of the arm or dog F; but if any extraordinary end pressure is exerted against the end of the link, the lever will be moved to or beyond the position shown in Fig. 3, its arm *d* assuming such an angle that the link *h* will move upward toward the pivot *a*, thereby reducing the pressure of the spring upon the lever, so that the latter presents comparatively little resistance to the inward passage of the link to its full length, while at the same time the undue straining of the spring is prevented.

I claim as my invention—

1. A coupling-head having on the top a

projection, H, adapted to an opening in the framing of the car, as and for the purpose set forth.

2. The combination of the coupling-head with the pivoted lever F and spring-rod *e*, connected to the short arm of the lever, as set forth.

3. The combination of the spring-rod *e* and the hooked short arm *d* of the lever F with

the connecting-link *h*, as set forth, for the purpose specified.

In testimony whereof I have signed my name to this specification in the presence of two subscribing witnesses.

JOHN J. LAHAYE.

Witnesses:

HARRY HOWSON, Jr.,

HARRY SMITH.