

(19) World Intellectual Property  
Organization  
International Bureau



(43) International Publication Date  
3 June 2004 (03.06.2004)

PCT

(10) International Publication Number  
WO 2004/047222 A1

- (51) International Patent Classification<sup>7</sup>: H01Q 1/38, 92109 (US). SHAMBLIN, Jeff; 718 Avenida Leon, San Diego, CA 92069 (US).  
1/24, 9/16
- (21) International Application Number: PCT/US2003/037031 (74) Agents: ALBERT, Peter, G. et al.; Foley & Lardner, P.O. Box 80278, San Diego, CA 92138-0278 (US).
- (22) International Filing Date: 18 November 2003 (18.11.2003) (81) Designated States (national): AE, AG, AL, AM, AT, AU, AZ, BA, BB, BG, BR, BW, BY, BZ, CA, CH, CN, CO, CR, CU, CZ, DE, DK, DM, DZ, EC, EE, EG, ES, FI, GB, GD, GE, GH, GM, HR, HU, ID, IL, IN, IS, JP, KE, KG, KP, KR, KZ, LC, LK, LR, LS, LT, LU, LV, MA, MD, MG, MK, MN, MW, MX, MZ, NI, NO, NZ, OM, PG, PH, PL, PT, RO, RU, SC, SD, SE, SG, SK, SL, SY, TJ, TM, TN, TR, TT, TZ, UA, UG, UZ, VC, VN, YU, ZA, ZM, ZW.
- (25) Filing Language: English (84) Designated States (regional): ARIPO patent (BW, GH, GM, KE, LS, MW, MZ, SD, SL, SZ, TZ, UG, ZM, ZW), Eurasian patent (AM, AZ, BY, KG, KZ, MD, RU, TJ, TM), European patent (AT, BE, BG, CH, CY, CZ, DE, DK, EE, ES, FI, FR, GB, GR, HU, IE, IT, LU, MC, NL, PT, RO, SE, SI, SK, TR), OAPI patent (BF, BJ, CF, CG, CI, CM, GA, GN, GQ, GW, ML, MR, NE, SN, TD, TG).
- (26) Publication Language: English
- (30) Priority Data:  
10/298,870 18 November 2002 (18.11.2002) US  
10/309,484 3 December 2002 (03.12.2002) US  
10/328,799 24 December 2002 (24.12.2002) US
- (71) Applicant: ETHERTRONICS, INC. [US/US]; 9605 Scranton Road, Suite 850, San Diego, CA 92121 (US).  
(72) Inventors: DESCLOS, Laurent; 3926 Camino Calma, San Diego, CA 92122 (US). POILASNE, Gregory; 1071 J. Street, San Diego, CA 92101 (US). ROWSON, Sebastian; 2609 Pico Place, Apartment 217, San Diego, CA
- Published:  
— with international search report

[Continued on next page]

(54) Title: MULTIPLE FREQUENCY CAPACITIVELY LOADED MAGNETIC DIPOLE

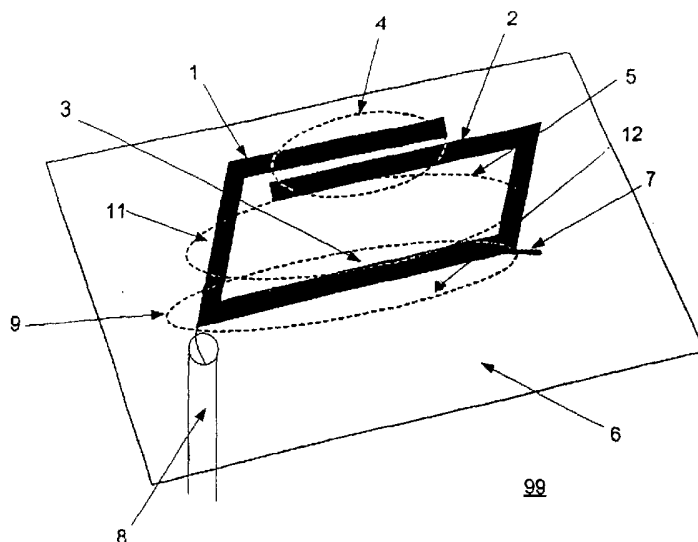

(57) Abstract: The disclosed embodiments of the present invention include an antenna element (52) having a generally low profile and providing a large bandwidth. Designs and physical configurations for multi-frequency, low-profile, capacitively loaded magnetic dipole antennas [296] with active elements to be used in wireless communications covering multiple band application are provided. The disclosed embodiments include antenna elements (52) having a top section (68) with at least one cutout (70). Each cutout (70) is provided with one or more tongues (72, 74) therein. Each tongue (72, 74) may be positioned separately to produce the desired antenna element characteristics. A capacitively coupled dipole antenna is provided with one or more active control elements. The active control elements may be used to effectuate changes in the operating characteristics of the antenna.

WO 2004/047222 A1



- 
- *before the expiration of the time limit for amending the claims and to be republished in the event of receipt of amendments*
- For two-letter codes and other abbreviations, refer to the "Guidance Notes on Codes and Abbreviations" appearing at the beginning of each regular issue of the PCT Gazette.*

**MULTIPLE FREQUENCY CAPACITIVELY LOADED MAGNETIC DIPOLE****CROSS-REFERENCE TO RELATED APPLICATIONS**

This application relates to co-pending United States Patent Application Serial No. 10/309,484, filed on December 03, 2002, entitled "Multiple Frequency Antennas with Reduced Space and Relative Assembly," by L. Desclos et al., owned by the assignee of this application.

This application relates to co-pending United States Patent Application Serial No. 10/298,870, filed on November 18, 2002, entitled "Active Configurable Capacitively Loaded Magnetic Dipole," by G. Poilasne et al., owned by the assignee of this application.

This application relates to co-pending United States Patent Application Serial No. 10/328,799, filed on December 24, 2002, entitled "Mutli-Band Reconfigurable Capacitively Loaded Magnetic Dipole," by L. Desclos et al., owned by the assignee of this application.

**FIELD OF THE INVENTION**

The present invention relates generally to the field of wireless communications, and particularly to the magnetic dipole antennas.

**BACKGROUND**

The information contained in this section relates to the background of the art of the present invention without any admission as to whether or not it legally constitutes prior art.

As new generations of handsets and other wireless communication devices become smaller and embedded with more applications, new antenna designs will be needed to provide solutions to inherent limitations of these devices. With classical antenna structures, a certain physical volume is required to produce a resonant antenna structure at a particular radio frequency and with a particular bandwidth. In multi-band applications, more than one such resonant antenna structure may be required. With the advent of a new generation of wireless devices, such classical antenna structures will need to take into account beam switching, beam steering, space or polarization antenna diversity, impedance matching, frequency switching, mode switching, etc., in order to reduce the size of devices and improve their performance. The present invention addresses the need for improvement of prior antenna designs by addressing one or more of their limitations.

It is desirable that wireless communication devices operate anywhere in the world. Frequency bands, however, vary from country to country and region to region. Furthermore, service providers may require use of different applications, for example, the Global System for Mobile Communications (GSM) or Personal Communications Service (PCS). Consequently, antenna designs for wireless devices need to cover multiple frequency bands as well as address the frequency requirements of service provider applications in order to function globally. The present invention addresses limitations of previously existing antenna designs.

Since applications such as GSM and PCS are used in the context of wireless communications devices that have relatively small form-factors, an antenna should generally have a low profile.

Further, many wireless applications require a relatively large bandwidth. In order to achieve this large bandwidth, many wireless devices are required to employ either a large antenna element or multiple antenna elements. This solution is not practical for wireless devices which require the antenna to be accommodated in a relatively small package, thus requiring that the antenna have a low profile.

The present invention addresses the requirements of certain wireless communications applications by providing low-profile antennas that may provide a larger bandwidth.

### **SUMMARY OF THE INVENTION**

The present invention relates to an antenna element having a generally low profile and providing a larger bandwidth. One aspect of the present invention includes antenna elements having a top section with at least one cutout. Each cutout is provided with one or more tongues therein. The tongues extend from an edge of the cutout inward. The tongues may be coplanar with the top section or may be positioned between the top section and a bottom plate. Each tongue may be positioned separately to produce the desired antenna element characteristics.

Another aspect of the present invention includes an active configurable capacitively loaded magnetic dipole antenna. In one embodiment, a device comprises a plurality of portions, the plurality of portions coupled to define a capacitively loaded dipole antenna; and at least one active control element, wherein the at least one control element is electrically coupled to one or more of the portions. One or more of the plurality of portions may define a capacitive area, wherein at least one control element is disposed generally in the capacitive area. One or more of the plurality of portions may define an inductive area, wherein at least one control element is

disposed generally in the inductive area. One or more of the plurality of portions may define a feed area, wherein at least one control element is disposed generally in the feed area. The plurality of portions may comprise a top portion, a middle portion, a bottom portion; wherein the top portion is coupled to the bottom portion; wherein the bottom portion is coupled to the middle portion, and wherein the middle portion is disposed generally between the top portion and the bottom portion. The top portion and the middle portion may define a capacitive area, wherein the middle portion and the bottom portion define an inductive area. At least one control element may be disposed in the capacitive area. At least one control element may be disposed in the inductive area. The at least one control element may be coupled to the top portion and to the middle portion. The at least one control element may be coupled to the middle portion and to the bottom portion. The at least one control element may be disposed to couple the top portion to the bottom portion. The at least one control element may be disposed to couple the bottom portion to the middle portion. The one or more control element may comprise a switch. The one or more control element may exhibit active capacitive or inductive characteristics. The one or more control element may comprise a transistor device. The one or more control element may comprise a field-effect transistor (FET) device. The one or more control element may comprise a micro-electrical mechanical systems (MEMS) device. The device may further comprise a wireless communications device, a feed point, and a ground point; wherein the wireless communications device is coupled to the antenna through the feed point and the ground point.

In one embodiment an antenna comprises a ground plane; a first conductor having a first length extending generally longitudinally above the ground plane and having a first end electrically connected to the ground plane at a first location; a second conductor having a second length extending generally longitudinally above the ground plane, the second conductor having a first end electrically connected to the ground plane at a second location; an antenna feed coupled to the first conductor; and a first active component, the first active component comprising a control input, wherein an input to the control input enables characteristics of the antenna to be configured. The first and second conductors may overlap to form a gap, wherein the first active component is disposed in the gap. The first conductor or the second conductor may comprise the first active component. The first active component may be disposed between the second conductor and the ground plane. The first active component may be disposed between the first conductor and the ground plane. The first active component may be disposed between the feed

and the ground plane. The antenna may further comprise a first stub coupled to the feed. The first stub may comprise the first active component. The first active component may be disposed between the first stub and the ground plane. The antenna may further comprise a second stub and a second active component, wherein the first stub comprises the first active component, and wherein the second active component is coupled between the second stub and the ground plane.

In one embodiment a device may comprise a ground plane, the ground plane comprising a first side and a second side; a first capacitively loaded dipole antenna; and a second capacitively loaded dipole antenna, wherein the first antenna is coupled to a first side of the ground plane, and wherein the second antenna is coupled to a second side of the ground plane. The device may further comprise a first active component, the first active component comprising a first control input, wherein an input to the first control input enables characteristics of the first antenna to be configured; and a second active component, the second active component comprising a second control input, wherein an input to the second control input enables characteristics of the second antenna to be configured.

In one embodiment a capacitively loaded dipole antenna may comprise control means for actively controlling characteristics of the antenna. In one embodiment a method for actively controlling characteristics of a capacitively loaded dipole antenna may comprise the steps of providing a capacitively loaded dipole antenna; providing a control element, the control element coupled to the antenna; providing an input to the control element; and controlling the characteristics of the antenna with the input.

Another aspect of the present invention relates to one or more simple, efficient, low cost, small form-factor antenna designs comprising one or more portions and/or one or more gap formed thereby. Each antenna design provides an antenna that exhibits one or more characteristic, for example, resonant frequency or impedance characteristics. One or more control portion/element is provided with each antenna design to actively re/configure one or more of the antenna characteristics.

In one embodiment, a wireless communications device comprises a multiple band capacitively coupled dipole antenna including the following: one or more antenna characteristic, a ground portion, a conductor coupled to the ground portion and disposed in an opposing relationship to the ground portion, and a control portion/element coupled to the antenna to enable active reconfiguration of the one or more antenna characteristic.

In one embodiment, an antenna comprises one or more antenna characteristic; a ground portion; a conductor coupled to the ground portion, the conductor disposed in an opposing relationship to the ground portion; and a control portion coupled to the antenna to enable active reconfiguration of the one or more antenna characteristic. The conductor may comprise a plurality of conductor portions, and the control portion may be coupled between two of the conductor portions. The conductor may comprise a plurality of conductor portions, wherein one or more gap is defined by the conductor portions, and wherein the control portion is disposed in a gap defined by two of the conductor portions. The control portion may be disposed in a gap defined by the ground portion and the conductor, and the control portion may be coupled to the ground portion and the conductor. The antenna may further comprise a stub, wherein the stub comprises one or more stub portion, and wherein at least one stub portion is coupled to the conductor portion. A first end of a control portion may be coupled to one stub portion and a second end of a control portion may be coupled to a second stub portion. A first end of a control portion may be coupled to one stub portion and a second end of a control portion may be coupled to the ground portion. A first end of a control portion may be coupled to one stub portion and a second end of a control portion may be coupled to the conductor. The conductor may comprise a plurality of conductor portions, and a control portion may be coupled between two of the conductor portions. The conductor may comprise a plurality of conductor portions, and a control portion may be coupled between two of the conductor portions. The control portion may comprise a switch. The control portion may exhibit active capacitive or inductive characteristics. The control portion may comprise a transistor device. The control portion may comprise a FET device. The control portion may comprise a MEMs device. The ground portion and the plurality of conductor portions may be coupled to define a capacitively coupled magnetic dipole antenna. The stub may be disposed on the ground portion. The stub may be disposed between the ground portion and the conductor. The antenna may comprise a multiple band antenna.

In one embodiment, a device comprises an antenna; with the antenna comprising one or more antenna characteristic, a ground portion, a conductor coupled to the ground portion and disposed in an opposing relationship to the ground portion, and a control portion coupled to the antenna to enable active configuration of the one or more antenna characteristic. The control portion may be coupled to a conductor portion. The control portion may be coupled to a stub portion. The control portion may comprise a switch. The control portion may exhibit active

capacitive or inductive characteristics. The control portion may comprise a transistor device. The control portion may comprise a FET device. The control portion may comprise a MEMS device. The ground portion and the plurality of conductor portions may be coupled to define a capacitively coupled magnetic dipole antenna.

In one embodiment, a method for actively controlling characteristics of a multiple-band capacitively coupled dipole antenna may comprise the steps of: providing a capacitively loaded dipole antenna, the antenna comprising one or more characteristic; coupling a control portion to the antenna; providing an input to the control portion; and controlling the one or more characteristic with changes to the input.

In a preferred embodiment, the present invention relates to a capacitively loaded dipole antenna having a control portion, a cutout portion and tongues, wherein each tongue may be positioned separately to produce the desired antenna element characteristics and further wherein the control portion provides a means for controlling certain antenna element characteristics.

#### **BRIEF DESCRIPTION OF THE DRAWINGS**

Figure 1A illustrates a three-dimensional view of one embodiment of an antenna element for use, for example, in wireless devices.

Figure 1B illustrates a side-view of the antenna element of Figure 1A.

Figure 1C illustrates a top-view of the antenna element of Figures 1A and 1B.

Figure 2A illustrates a top-view of another embodiment of an antenna element for use, for example, in wireless devices.

Figures 2B-2D illustrate side-views of various configurations of the antenna element of Figure 2A.

Figure 3A illustrates a three-dimensional view of an embodiment of an antenna element in accordance with the present invention.

Figure 3B illustrates a three-dimensional view of another embodiment of an antenna element in accordance with the present invention.

Figure 3C illustrates a three-dimensional view of another embodiment of an antenna element in accordance with the present invention.

Figure 4A illustrates a three-dimensional view of yet another embodiment of an antenna element in accordance with the present invention.

Figure 4B illustrates a side-view of the antenna element of Figure 4A.



Figure 4C illustrates a three-dimensional view of another embodiment of an antenna element in accordance with the present invention.

Figure 4D illustrates a side-view of the antenna of Figure 4C.

Figure 4E illustrates a three-dimensional view of another embodiment of an antenna element in accordance with the present invention.

Figure 4F illustrates a side-view of the antenna element of Figure 4E.

Figure 5A illustrates a three-dimensional view of yet another embodiment of an antenna element in accordance with the present invention.

Figure 5B illustrates a side-view of the antenna element of Figure 5A.

Figure 6 illustrates a three-dimensional view of another embodiment of an antenna in accordance with the present invention.

Figure 7A illustrates a three-dimensional view of an embodiment of an antenna element assembly in accordance with the present invention.

Figure 7B illustrates a three-dimensional view of the antenna element assembly of Figure 7A in a completely assembled configuration.

Figure 8A illustrates a three-dimensional view of another embodiment of an antenna element assembly in accordance with the present invention.

Figure 8B illustrates a three-dimensional view of one embodiment of an assembly module for use with the antenna element assembly of Figure 8A.

Figure 9 is a chart illustrating side-views of various embodiments of an antenna element in accordance with the present invention.

Figure 10 illustrates a three-dimensional view of a capacitively loaded magnetic dipole.

Figure 11 illustrates a side-view of a capacitively loaded magnetic dipole.

Figure 12A illustrates a side-view of one embodiment of a capacitively loaded magnetic dipole wherein a control element has been included in area.

Figure 12B illustrates a side-view of one embodiment of a capacitively loaded magnetic dipole where a control element has been included in area.

Figure 13A illustrates a side-view of one embodiment of a capacitively loaded magnetic dipole where a control element has been included in area .

Figure 13B illustrates a side-view of one embodiment of a capacitively loaded magnetic dipole where a control element has been included in area.

Figure 13C illustrates a side-view of one embodiment of a capacitively loaded magnetic dipole where a control element has been included in area.

Figure 14A illustrates a side-view of one embodiment of a capacitively loaded magnetic dipole where a control element has been included in area.

Figure 14B illustrates a side-view of one embodiment of a capacitively loaded magnetic dipole where a control element has been included in area.

Figure 15A illustrates a three-dimensional view of one embodiment of a capacitively loaded magnetic dipole, comprising a capacitive area, and an inductive area on which a stub has been added along a feed area.

Figure 15B illustrates a three-dimensional view of one embodiment of a capacitively loaded magnetic dipole, comprising a capacitive area, and an inductive area on which a stub has been added along a feed area.

Figure 16A illustrates a three-dimensional view of one embodiment of a capacitively loaded magnetic dipole, comprising a capacitive area, an inductive area, and a stub along which is placed a control element.

Figure 16B illustrates a three-dimensional view of one embodiment of a capacitively loaded magnetic dipole, comprising a capacitive area, an inductive area, and a stub at the tip of which is placed a control element.

Figure 16C illustrates a three-dimensional view of one embodiment of a capacitively loaded magnetic dipole, comprising a capacitive area, an inductive area, and multiple stubs with control elements placed on them.

Figure 17 illustrates a three-dimensional-view of one embodiment of a capacitively loaded magnetic dipole, comprising a capacitive area, an inductive area, and a stub.

Figure 18A illustrates a top view of one embodiment of two capacitively loaded magnetic dipoles flush and parallel on both sides of a ground plane with each of the radiating elements including a control element.

Figure 18B illustrates a top view of one embodiment of two capacitively loaded magnetic dipoles flush back to back on both sides of a ground plane with each of the radiating elements including a control element.

Figure 19A illustrates one embodiment of two capacitively loaded magnetic dipoles back to back, sharing the connection from a top portion to a bottom portion wherein along the shared connection is a control element.

Figure 19B illustrates one embodiment of two capacitively loaded magnetic dipoles sharing the connection from a top portion to a bottom portion.

Figure 20 illustrates a 3D structure comprising multiple capacitively loaded magnetic dipoles, sharing common areas with control elements placed in different areas.

Figure 21A illustrates a three dimensional view of an antenna.

Figure 21B illustrates a side-view of an antenna.

Figure 21C illustrates a bottom-view of a top portion of an antenna.

Figures 22A-B illustrate views of an antenna and a control portion.

Figures 23A-C illustrate views of an antenna and a control portion.

Figures 24A-D illustrate views of an antenna and a control portion.

Figures 25A-B illustrate views of an antenna and a control portion.

Figures 26A-B illustrate views of an antenna and a control portion.

Figure 27A illustrates resonant frequencies of a dual band capacitively loaded magnetic dipole antenna.

Figures 27B-D illustrate views of an antenna and a control portion.

Figures 28A-B illustrate views of an antenna and a stub.

Figures 29A-B illustrate views of an antenna, a control portion, and a stub.

Figures 30A-C illustrate views of an antenna, a control portion, and a stub.

Figure 31A illustrates views of an antenna, control portions, and a stub.

### **DETAILED DESCRIPTION OF THE INVENTION**

In the following description, for purposes of explanation and not limitation, specific details are set forth in order to provide a thorough understanding of the present invention. However, it will be apparent to one skilled in the art that the present invention may be practiced in other embodiments that depart from these specific details. In other instances, detailed descriptions of well-known methods and devices are omitted so as to not obscure the description of the present invention with unnecessary detail.

The present invention generally relates to capacitively loaded magnetic dipole antenna (CLMD). In one aspect of the present invention, a CLMD antenna produces a specific

frequency, band of frequency, or combination therein for targeted applications like GSM and PCS. The resonant frequency is a result of the inductance and capacitance components. CLMD antennas present various advantages, chief among them is excellent isolation. In order to provide greater bandwidth, the confinement of the antenna may be relaxed. The various embodiments described below effectively relax the confinement of the antenna.

Figure 1A-1C illustrate one embodiment of a single CLMD antenna element 10. The antenna element 10 includes a top section 12 and a bottom plate 14. The top section 12 is cut to include two top plates 16, 18 and a connection section 20 connecting the two top plates 16, 18. The two top plates 16, 18 are substantially coplanar and are separated by a gap 22.

The top section 12 is separated from the bottom plate 14 by a distance which may be varied to achieve desired antenna element characteristics. Feeding points 24 provide the necessary separation between the top section 12 and the bottom plate 14. A feed line 26 is adapted to provide electrical charge to the top section 12.

The two top plates 16, 18 comprise a capacitance component 28 (Figures 1A and 1C) of the antenna element 10. A loop between the two top plates 16, 18 and the bottom plate 14 comprises an inductance component 30 (Figure 1B) of the antenna element 10.

One way to further relax the confinement of the antenna 10 is to increase the gap 22 between the two top plates 16, 18. At a certain point, the capacitance component 28 of the antenna element 10 becomes too small to keep a low frequency due to the increased gap 22 between the two top plates 16, 18. The reduction in capacitance is compensated by an increase in the inductance obtained from the connection section 20 of the top section 12.

The bandwidth obtained by a relaxed CLMD antenna element of the type illustrated in Figures 1A-1C may have to be further increased for certain applications. In this case, the bandwidth may be improved by adding a bridge over the gap between the two top plates. The bridge may be used to provide a second frequency band for the antenna element. Figure 2A illustrates a top-view of an embodiment of a CLMD antenna element using such a bridge. The antenna element 32 includes a top section 34 and a bottom plate 36. The top section 34 includes two top plates 38, 40 separated by a gap. The two top plates 38, 40 comprise a capacitance component 41 of the antenna element 32. The antenna element 32 is also provided with a bridge 42 overlaying at least part of the gap between the two top plates 38, 40. The bridge 42 provides the antenna element 32 with a wider bandwidth.

Figures 2B-2D illustrate side-views of various configuration of the antenna element 32 of Figure 2A. In the illustrated embodiments, feeding points 44 provide a gap between the top section 34 and the bottom plate 36. In the embodiment illustrated in Figure 2B, the bridge 42 is electrically connected to both top plates 38, 40. In another embodiment, illustrated in Figure 2C, the bridge is electrically connected to one top plate 38 and capacitively loaded on the other top plate 40, forming a capacitance component 48. In yet another embodiment, illustrated in Figure 2D, the bridge is capacitively loaded on both top plates 38, 40, forming capacitance components 48, 50. In the embodiments illustrated in Figures 2C and 2D, adjustment of the vertical distance between the bridge 42 and a top plate 38, 40 will tune the frequency of the antenna element 32. In the embodiment illustrated in Figure 2D, a spacer or insert (not shown) may be used to maintain the placement of the bridge relative to the top plates.

Figure 3A illustrates a three-dimensional view of an embodiment of an antenna element in accordance with the present invention. In this illustration, an antenna element 52 having a bottom plate 54 and a top section 56 is provided with a cutout 58 in a central region of the top section 56. The cutout 58 in the embodiment illustrated in Figure 3A is of a rectangular configuration. However, it will be understood by those skilled in the art that other configurations are possible.

A tongue 60 extends from one edge of the cutout 58 into the cutout 58. The tongue 60 may be integrally formed with the top section 56. As with the cutout 58, although the tongue 60 in the illustrated embodiment has a rectangular configuration, other configurations are also contemplated. In the illustrated embodiment, the tongue 60 extends from the edge of the cutout 58 nearest feeding points 62 connecting the top section 56 to the bottom plate 54. The position, shape, and size of the tongue may be selected to tune the antenna element 52 to meet the frequency requirements of a targeted application. In the illustrated embodiment, the top section 56 and the tongue 60 are coplanar.

Figure 3B illustrates a three-dimensional view of another embodiment of an antenna element in accordance with the present invention. The antenna element 64 illustrated in Figure 3B is similar to the antenna element 52 illustrated in Figure 3A, having a bottom plate 66 and a top section 68 with a central cutout 70. In this embodiment illustrated in Figure 3B, the cutout 70 in the top section 68 is provided with two tongues 72, 74 extending from opposite edges of the cutout 70. The two tongues 72, 74 act with the ground plate 66 as a capacitance

component of the antenna element 64. The position, shape, and size of the tongues may be adjusted to tune the antenna to meet the frequency requirements of the targeted application. Further, although the tongues 72, 74 illustrated in Figure 3B are substantially identical, mirror-images, other embodiments may include two tongues 72, 74 that are dissimilar in shape, size or other characteristics. Although the embodiment illustrated in Figure 3B includes two tongues 72, 74 in the cutout 70, any practical number of tongues may be provided within a cutout. The number of tongues may be selected to achieve the desired characteristics of the antenna element 64.

While the antenna element 64 illustrated in Figure 3B includes two tongues 72, 74 extending from opposite edges, other configurations are also possible. For example, Figure 3C illustrates a three-dimensional view of an embodiment of an antenna element 76 in accordance with the present invention having two tongues 78, 80 in a cutout 82 in a top section 84, with both tongues 78, 80 extending from the same edge of the cutout 82.

Figures 4A and 4B illustrate another embodiment of an antenna element in accordance with the present invention. In this embodiment, the antenna element 86 is similar to the antenna element described above with reference to Figure 3C, having a bottom plate 88, a top section 90 with a central cutout 92. In the embodiment illustrated in Figures 4A and 4B, two tongues 94, 96 are provided in the cutout 92 with the tongues 94, 96 being positioned out of the plane of the top section 90. As most clearly illustrated in Figure 4B, each tongue, such as tongue 96 is still attached to the top section 90 of the antenna element 86 and is positioned between the top section 90 and the bottom plate 88 with a vertical extension 98. In the embodiment illustrated in Figure 4A and 4B, the vertical extension 98 projects downward substantially perpendicular to the plane of the top section 90. In other embodiments, the vertical extension 98 may project at slanted angles, for example. Although the two tongues 94, 96 are illustrated in Figures 4A and 4B as being coplanar with respect to each other, other embodiments may include tongues in different horizontal planes.

Figures 4C and 4D illustrate another embodiment of an antenna element in accordance with the present invention. The illustrated antenna element 100 includes a top section 102 with two cutouts 104, 106 in a central region of the top section 102. In the embodiment illustrated in Figures 4C and 4D, the two cutouts 104, 106 are arranged in an aligned configuration along a longitudinal axis. In other embodiments, cutouts may be aligned along other axes or may be

position in a non-aligned manner. Further, although the illustrated embodiment includes two cutouts in the top section 102, any practical number of cutouts may be provided. The number of cutouts may be selected to provide the desired antenna element characteristics.

Referring again to Figures 4C and 4D, each cutout 104, 106 is provided with two tongues, such as tongues 108, 110 in cutout 106. As most clearly illustrated in Figure 4D, the tongues are positioned in a coplanar configuration relative to each other in a plane below the plane of the top section 102. As noted above, the tongues are not required to be coplanar with respect to other tongues.

Figures 4E and 4F illustrate another embodiment of an antenna element in accordance with the present invention. The illustrated antenna element 112 includes a top section 114 having two cutouts 116, 118. The cutout 116 is provided with two tongues 120, 122 arranged in a manner similar to tongues 94, 96 of the antenna element 86 described above with reference to Figure 4A. On the other hand, the cutout 118 is provided with two tongues 124, 126 extending from opposing edges of the cutout 118. The tongues 124, 126 are positioned so that a portion of the tongues in a center portion of the cutout 118 are in a side-by-side configuration.

Figures 5A and 5B illustrate another embodiment of an antenna element in accordance with the present invention. In this illustration, an antenna element 128 is provided with a top section 130 having two cutouts 132, 134. The first cutout 132 is provided with a pair of tongues 136, 138 extending from opposing edges of the cutout 132. In the illustrated embodiment, the tongues 136, 138 are flaps having a width substantially equal to the width of the cutout 132. The length of the tongues 136, 138 may be different from each other, as illustrated in Figures 5A and 5B. The second cutout 134 is provided with four tongues 140, 142, 144, 146 alternately extending from opposing edges of the cutout 134. The embodiment illustrated in Figures 5A and 5B includes a total of six tongues, all of which are coplanar relative to each other, but in a different plane from the plane of the top section 130. In other embodiments, the tongues may be in different planes from each other, and one or more tongues may be in the same plane as the top section.

Figure 6 illustrates a three dimensional view of another embodiment of an antenna element in accordance with the present invention. The illustrated antenna element 148 includes a top section 150 positioned above a bottom plate 152. The top section 150 is provided with a cutout 154 in a central region of the top section 150. The cutout 150 may be sized to

accommodate an insert or a module (not shown) adapted to provide the desired antenna element characteristics. The insert or module may, as described below, include tongues similar to those described above. In this manner, a modular configuration may be achieved to facilitate interchangeability of components. Although the cutout 154 embodiment illustrated in Figure 6 is positioned in a central region of the top section 150, other embodiments may include a cutout located on an edge of the top section, for example.

In the illustrated embodiment, flaps, such as flaps 156, 158 extend downward from the outer edges of the top section 150 along each edge. The flaps may be provided to enhance isolation of the antenna element 148. For example, the flaps 156, 158 may serve to shape the field contained in the antenna element 148.

Figures 7A and 7B illustrate an embodiment of an antenna element assembly in accordance with the present invention. The antenna element assembly 160 includes a base section 162 having a bottom plate 163 and a top section 164. In other embodiments, the base section may be constructed in accordance with the antenna element described above with reference to Figure 6. Referring again to Figures 7A and 7B, the top section 164 is provided with a module-receiving opening 166 in a central region of the top section 164. The module-receiving opening 166 of the embodiment illustrated in Figure 7A and 7B has a rectangular configuration. However, other configurations will be apparent to those skilled in the art.

A separate tongue module 168 is sized to be accommodated by the module-receiving opening 166 of the top section 164 of the base section 162. The tongue module 168 is provided with a top surface 170 having a central cutout 171. One or more tongues, such as tongue 172, may be provided within the cutout 171, in a manner similar to that described above.

Figure 7B illustrates the antenna element assembly in an assembled configuration. In the illustrated embodiment, the top surface 170 of the tongue module 168 is substantially flush with the top section 164 of the base section. The tongue module 168 may be secured to the base assembly in any of a variety of well-known ways.

Although the embodiment illustrated in Figures 7A and 7B includes a top section having a single module-receiving opening for receiving a single tongue module, other embodiments may be adapted to accommodate a plurality of tongue modules in each top section.

Figure 8A illustrates another embodiment of an antenna element assembly in accordance with the present invention. The antenna element assembly 174 includes a base section 176. The



base section 176 includes a top section 178 having a module-receiving opening 180. Unlike the embodiment described above with reference to Figures 7A and 7B, the module-receiving opening 180 of the embodiment illustrated in Figure 8A is surrounded by the top section 178 on three sides and is open on the fourth side, forming a U-shaped opening. A tongue module 182 may be inserted into the module-receiving opening 180 through the fourth side, as indicated by the dark arrows in Figure 8A. The tongue module 182 illustrated in Figure 8A includes a top surface 184, which may be substantially flush with the top section 178 when assembled, and one or more tongues, such as tongue 186.

Figure 8B illustrates another embodiment of a tongue module for use with the base section 176 illustrated in Figure 8A. The tongue module 188 illustrated in Figure 8B includes a top surface 190 having a cutout 192. One or more tongues, such as tongue 192, may be provided within the cutout 192. The embodiment of Figure 8B further includes a downward-extending flap 194 on one edge of the top surface 190. The flap 194 may facilitate isolation of the antenna element, as described above with reference to Figure 6.

Figure 9 illustrates side-views of various embodiments of antenna elements in accordance with the present invention. As illustrated by the various embodiments shown in Figure 9, any number of combinations of tongues in any number of cutouts may be provided in an antenna element. The number of cutouts in a top section of an antenna element may be varied along with the number of tongues in each cutout. The positioning of each tongue may also be varied to produce the desired antenna element characteristics.

In another aspect of the present invention, different embodiments provide an antenna that may be actively changed or configured, with resultant small or large changes in characteristics of the antenna being achieved. One characteristic that is configurable is resonant frequency. In one embodiment, a frequency shift in the resonant frequency of the antenna can be actively induced, for example, to follow a spread spectrum hopping frequency (such as but not limited to Bluetooth and Home-RF). The present invention provides a very small and highly isolated antenna that covers a few channels at a time, with the ability to track hopping frequencies quickly, improving the overall system performance.

In one embodiment, an antenna is provided with frequency switching capability that may be linked to a particular user, device, or system defined operating mode. Mode changes are facilitated by active real time configuration and optimization of an antennas characteristics, for

example as when switching from a 800MHz AMPS/CDMA band to a 1900MHz CDMA band or from a 800/1900MHz U.S. band to a 900/1 800MHz GSM Europa and Asia band.

In one embodiment, the present invention comprises a configurable antenna that provides a frequency switching solution that is able to cover multiple frequency bands, either independently or at the same time.

In one embodiment, a software-defined antenna for use in a software defined device. The device may comprise a wireless communications device, which may be fixed or mobile. Examples of other wireless communications devices within the scope of the present invention include cell phones, PDAs, and other like handheld devices.

Communication devices and antennas operating in one or more of frequency bands used for wireless communication devices (for example, but not limited to 450MHz, 800MHz, 900MHz, 1.575GHz, 1.8GHz, 1.9GHz, 2GHz, 2.5GHz, 5GHz,) are considered to be within the scope of the invention. Other frequency bands are also considered to be within the scope of the present invention.

The present invention provides the ability to optimize antenna transmission characteristics in a network, including radiated power and channel characteristics.

In one or more embodiment, channel optimization may be achieved by providing a beam switching, beam steering, space diversity, and/or multiple input-multiple output antenna design. Channel optimization may be achieved by either a single element antenna with configurable radiation pattern directions or by an antenna comprising multiple elements. The independence between different received paths is an important characteristic to be considered in antenna design. The present invention provides reduced coupling between multiple antennas, reducing correlation between channels.

The antenna design of the present invention may also be used when considering radiated power optimization. In one embodiment, an antenna is provided that may direct the antenna near-field away from disturbances and absorbers in real time by optimizing antenna matching and near-field radiation characteristics. This is particularly important in handset and other handheld device designs, which may interact with human bodies (hands, heads, hips, . . .). In one embodiment, wherein one antenna is used in a communications device, input impedance may be actively optimized (control of the reflected signal, for example). In one embodiment

where a device comprises multiple antennas, each antenna may be optimized actively and in real time.

Figures 10 and 11 illustrate a respective three-dimensional view and a side view of an embodiment of a capacitively loaded magnetic dipole antenna (299). In one embodiment, the antenna (299) comprises a top (201), a middle (202), and a bottom (203) portion. The top (201) portion is coupled to bottom portion (203), and the bottom portion (203) is coupled to the middle portion (202). In one embodiment, the top portion (201) is coupled to the bottom portion (203) by a portion (211), and the bottom portion (203) is coupled to middle portion (202) by a portion (212). In one embodiment, the portion (211) and the portion (212) are generally vertical portions and generally parallel to each other, and the portions (201), (202), and (203) are generally horizontal portions and generally parallel to each other. It is understood, however, that the present invention is not limited to the illustrated embodiment, as in other embodiments the portions (201), (202), (03), (211), and/or (212) may comprise other geometries. For example, top portion (201) may be coupled to bottom portion (203) and bottom portion may be coupled to middle portion (202) such that one or more of the portions are generally in non-parallel and non-horizontal relationships. In embodiments that utilize a portion (211) and a portion (212), non-parallel and/or non-vertical geometries of portion (211) and (212) are also within the scope of the present invention. In one embodiment, portions (201), (202), (203), (211), and (212) may comprise conductors. In one embodiment, the portions (201), (202), (203), (211), and (212) may comprise conductive plate structures, wherein the plate structures of each portion are coupled and disposed along one or more plane. For example, in the embodiment of Figure 10 and Figure 11, plate portions are disposed and coupled along a plane that is vertical to a grounding plane (206). In another embodiment, plate portions may also be disposed and coupled along planes that are at right angles and/or parallel to the grounding plane (206). Thus, it is understood that the portions of antenna (299), as well as the portions of other antennas described herein, may comprise other geometries and other geometric structures and yet remain within the scope of the present invention.

In one embodiment, the bottom portion (203) is attached to a grounding plane (206) at a grounding point (207), and bottom portion (203) is powered through a feedline (208). The antenna (299) of Figures 10 and 11 may be modeled as an inductance/capacitance (LC) circuit, with a capacitance (C) that corresponds to a fringing capacitance that exists across the gap

defined generally by top portion (201) and middle portion (202), indicated generally as area (204), and with an inductance (L) that corresponds to an inductance that exists in an area indicated generally as area (205) and that is generally bounded by the middle portion (202) and the bottom portion (203). As will be understood with reference to the foregoing Description and Figures, the geometrical relationships of one or more portions in the capacitive area (204) may be utilized to effectuate large changes in the resonant frequency of the antenna (299), and the geometrical relationships between one or more portions in the inductive area (205) may be used to effectuate medium frequency changes. As well, geometrical relationships between one or more portions in a feed area (209) may be utilized to effectuate small frequency changes. The areas (204), (205), and (209) may also be utilized for input impedance optimization.

Figure 12A illustrates a side-view of a capacitively loaded magnetic dipole antenna (298), wherein a control element (231) is disposed generally in area (204). In the illustrated embodiment, control element (231) is electrically coupled at one end to top portion (201) and at another end to middle portion (202). In one embodiment, control element (231) comprises a device that may exhibit ON-OFF and/or actively controllable capacitive/inductive characteristics. In one embodiment, control element (231) may comprise a transistor device, a FET device, a MEMs device, or other suitable control element or circuit capable of exhibiting ON-OFF and/or actively controllable capacitive/inductive characteristics. It is identified that control element (231), as well as other control elements described further herein, may be implemented by those of ordinary skill in the art and, thus, control element (231) is described herein only in the detail necessary to enable one of such skill to implement the present invention. In one embodiment wherein the control element (231) comprises a switch with ON characteristics, the capacitance in area (204) is short-circuited, and antenna (298) may be switched off, no energy is radiated. In one embodiment, wherein the capacitance of the control element (231) may be actively changed, for example, by a control input to a connection of a FET device or circuit connected between top portion (201) and middle portion (202), the control element (231) will be understood by those skilled in the art as capable of acting generally in parallel with the fringing capacitance of area (204). It has been identified that the resulting capacitance of the control element (231) and the fringing capacitance may be varied to change the LC characteristics of antenna (98) or, equivalently, to vary the resonant frequency of the antenna (298) over a wide range of frequencies.

Figure 12B illustrates a side-view of a capacitively loaded magnetic dipole antenna (297), wherein a control element (231) is disposed generally in area (204). In the illustrated embodiment, control element (231) is electrically coupled at one end to top portion (201) and at another end to a tip portion. In one embodiment, control element (231) comprises a device that may exhibit ON-OFF and/or actively controllable capacitive/inductive characteristics. In one embodiment, control element (231) may comprise a transistor device, a FET device, a MEMS device, or other suitable control element. In one embodiment, wherein the control element (2031) electrically couples or decouples the tip portion (213) from the top portion (201), for example as by the ON characteristics of a switch, the length of top portion (201) of antenna (297) may be increased or decreased such that the capacitance in area (204) may be changed to actively change the resonant frequency of antenna (297) from one resonant frequency to another resonant frequency. In one embodiment, wherein the capacitance of the control element (231) may be actively changed, for example, by a control input of a FET device or circuit, the control element (231) will be understood by those skilled in the art as capable of acting generally in series with the fringing capacitance of area (204). It has been identified that the resulting capacitance may be varied to actively change the LC characteristics of antenna (297) or, equivalently, to vary the resonant frequency of the antenna (298) over a wide range of frequencies.

Figure 13A illustrates a side-view of a capacitively loaded magnetic dipole antenna (296), wherein a control element (241) is disposed generally in area (205). In the illustrated embodiment, control element (241) is electrically coupled at one end to bottom portion (203) and at another end to middle portion (202). In one embodiment, control element (241) comprises a device that may exhibit ON-OFF and/or actively controllable capacitive or inductive characteristics. In one embodiment, control element (241) may comprise a transistor device, a FET device, a MEMS device, or other suitable control element or circuit. In one embodiment wherein the control element (241) exhibits ON characteristics, the inductance in area (204) is short-circuited and antenna (296) may be switched off. In one embodiment, the inductance of the control element (231) may be actively changed, for example, by a control input to a device or circuit connected between the bottom portion (203) and the middle portion (202). Such control circuits are known in the art, such as for example, a device or circuit that enables active control of inductance is presented in "Broad band monolithic microwave active inductor and its application to miniaturize wide band amplifiers" presented in IEEE Trans. Microwave Theory

Tech, vol. 36, pp. 1020-1924, Dec. 1988 by S. Hara, T. Tokumitsu, T. Tanaka, and M. Aikawa. Control element (241) will be understood by those skilled in the art as capable of acting as an inductor generally in parallel with the inductance of area (205). It has been identified that the resulting inductance may be varied to change the LC characteristics of antenna (296) or, equivalently, to vary the resonant frequency of the antenna (296) over a medium range of frequencies.

Figure 13B illustrates a side-view of a capacitively loaded magnetic dipole antenna (295), wherein a control element (241) is disposed generally in area (205) at a break in portion (211) and electrically coupled at one end to top portion (201) and at another end to bottom portion (203). In one embodiment, control element (241) comprises a device that may exhibit ON-OFF and/or actively controllable capacitive or inductive characteristics. In one embodiment, control element (241) may comprise a transistor device, a FET device, a MEMs device, or other suitable control element or circuit. In one embodiment, wherein the control element (241) exhibits OFF characteristics, it has been identified that the LC characteristics of the antenna (295) may be changed such that antenna (295) operates at a frequency 10 times higher than the frequency at which the antenna operates with a control element that exhibits ON characteristics. In one embodiment, wherein the inductance of the control element (241) may be actively controlled, it has been identified that the resonant frequency of the antenna (295) may be varied quickly over a narrow bandwidth.

Figure 13C illustrates a side-view of a capacitively loaded magnetic dipole antenna (294), wherein a control element (241) is disposed generally in area (205) and electrically coupled at a break in portion (212) at one end to a middle portion (202) and at another end to bottom portion (203). In one embodiment, control element (241) comprises a device that may exhibit ON-OFF and/or actively controllable capacitive or inductive characteristics. In one embodiment, control element (241) may comprise a transistor device, a FET device, a MEMs device, or other suitable control element or circuit. In one embodiment, wherein the control element (241) exhibits OFF characteristics, it has been identified that the LC characteristics of the antenna (294) may be changed such that antenna (294) operates at a frequency 10 times higher than the frequency at which the antenna operates with a control element that exhibits ON characteristics. In one embodiment, wherein the inductance of the control element (241) may be actively controlled, it

has been identified that the resonant frequency of the antenna (294) may be changed quickly over a narrow bandwidth.

Figure 14A illustrates a side-view of a capacitively loaded magnetic dipole antenna (293), wherein a control element (251) is disposed generally in area (209) and coupled at one end generally at feed point (208) and at another end along the bottom portion (203) and along grounding plane (206). In one embodiment, control element (251) comprises a device that may exhibit ON-OFF and/or actively controllable capacitive or inductive characteristics. In one embodiment, control element (251) may comprise a transistor device, a FET device, a MEMS device, or other suitable control element or circuit. In one embodiment, wherein the control element (251) exhibits ON characteristics, the antenna (293) is short-circuited and no power is either radiated or received by the antenna (293). With a control element exhibiting OFF characteristics, the antenna (293) may operate normally. In one embodiment, wherein the inductance and/or capacitance of the control element (251) may be controlled, it has been identified that it is possible to control the input impedance of the antenna such that the input impedance may be adjusted in order to maintain the test antenna characteristics while the antenna's environment is changing.

Figure 14B illustrates a side-view of a capacitively loaded magnetic dipole antenna (292), wherein a control element (251) is disposed generally in feed area (209) and coupled at one end to bottom portion (203) and coupled at another end at a ground point. In one embodiment, wherein the control element exhibits ON characteristics, the antenna (292) operates normally, whereas with OFF characteristics exhibited by the control element, the antenna acts as an open circuit; in one embodiment, wherein the inductance and capacitance of the control element (251) may be controlled, it has been identified that it is possible to control the input impedance of the antenna. In one embodiment, the input impedance may thus be adjusted while the antenna environment is changing in order to maintain the best antenna characteristics.

Figure 15A illustrates a three-dimensional view of a capacitively loaded magnetic dipole antenna (291) comprising a capacitive (204) and an inductive (205) area, and further including a first stub (210) electrically coupled to a feedline (208). The first stub (210) may be used to increase the bandwidth of the capacitively loaded magnetic dipole antenna (291) and/or to create a second resonance to increase the overall usable bandwidth of the antenna (291).

Figure 15B illustrates a three-dimensional view of a capacitively loaded magnetic dipole antenna (290) comprising a capacitive (204) and an inductive (205) area, and further including a first stub (210) coupled to a feedline (208), and a second stub (213) electrically coupled to the feedline (208).

Figure 16A illustrates a three-dimensional view of a capacitively loaded magnetic dipole antenna (289) comprising a capacitive area (204), an inductive (205) area, and a stub (210). In one embodiment, the electrical continuity of stub (210) is interrupted by electrical connection of a control element (271), which as indicated in Figure 7A is disposed along a break in stub (210) between points (273) and (274). In one embodiment, control element (271) comprises a device that may exhibit ON-OFF and/or actively controllable capacitive or inductive characteristics. In one embodiment, control element (271) may comprise a transistor device, a FET device, a MEMs device, or other suitable control element or circuit. In one embodiment, with a control element (271) that exhibits ON characteristics, the entire length of stub (210) acts to influence the antenna (289) characteristics. With the control element (271) exhibiting OFF characteristics, only the part of the stub making electrical contact with the antenna acts to affect the LC circuit of the antenna (289). In one embodiment, it has been identified that by controlling the inductance and capacitance of control element (271) it is possible to achieve a controllable variation of frequency or bandwidth, or to effectuate impedance matching of the antenna (289).

Figure 16B illustrates a three-dimensional view of a capacitively loaded magnetic dipole antenna (288) comprising a capacitive (204) area, an inductive (205) area, and a stub (210). As illustrated in Figure 16B, one end of a control element (271) is electrically coupled to stub (210) at its end portion (272) and another end of stub (210) is coupled to a ground point. In one embodiment, control element (271) comprises a device that may exhibit ON-OFF and/or actively controllable capacitive or inductive characteristics. In one embodiment, control element (271) may comprise a transistor device, a FET device, a MEMs device, or other suitable control element or circuit. In one embodiment, wherein control element (271) exhibits ON characteristics, stub (210) is short-circuited. With the control element (271) comprising OFF characteristics, the stub (210) may act to influence the operating characteristics of antenna (288). In one embodiment wherein inductance and capacitance of the control element (271) may be actively controlled, it has been identified that it is possible to have a continuous variation of resonance frequency or bandwidth.



Figure 16C illustrates a three-dimensional view of a capacitively loaded magnetic dipole antenna (287), comprising a capacitive (204) area, an inductive (205) area, a first stub (210), and a second stub (213). In one embodiment, stub (210) and stub (213) may incorporate respective control elements (271) as referenced in Figures 16A and 16B, to effectuate changes in the LC characteristics of antenna (287) in accordance with descriptions previously presented herein.

Figure 17 illustrates a side view of a capacitively loaded magnetic dipole antenna (286) comprising a capacitive (204) area, an inductive (205) area, and a stub (210) (not visible in side view). In one embodiment, a control element (231) may be disposed in upper portion (201) to effectuate changes in the operating frequency of the antenna (286), for example, to effectuate changes from a 800/1900 MHz US frequency band to a 900/1900MHz GSM Europe and Asia frequency band. In one embodiment, a second control element (241) may be disposed in portion (212) to effectuate changes in the resonant frequency of antenna (286) over a range of frequencies. In one embodiment, a control element (251) may be disposed between lower portion (203) and a ground point to effectuate control of the input impedance as a function of loading of the antenna (286). A control feedback signal for effectuating control may be obtained by monitoring the quality of transmissions emanating from the antenna (286). In one embodiment, a control element may be disposed in the stub (210) to effectuate control of a second resonance corresponding to a transmitting band.

It is identified that one way to improve the transmission quality of an antenna is to switch an antenna's beam direction or to steer an antenna's beam. In one embodiment, beam switching may be obtained with two capacitively loaded magnetic dipoles that are switched ON or OFF using control elements as described herein.

Figure 18A illustrates a top view of two capacitively loaded magnetic dipole antennas (284, 285). In one embodiment, each antenna is opposingly disposed flush and parallel to a ground plane (206). In one embodiment, each antenna (284, 285) may comprise respective control elements (293, 294). By controlling each control element (293, 294) to exhibit ON-OFF characteristics, respective radiating elements comprising a top portion (201) of a respective antenna can be turned OFF or ON to effectuate utilization of one antenna or the other. With both control elements (293, 294) exhibiting OFF characteristics, both antennas (284, 285) may be utilized to provide a wider radiation pattern.

Figure 18B illustrates a top view of two capacitively loaded magnetic dipole antennas (282, 283). In one embodiment, each antenna is opposingly disposed flush and back to back on both sides of a ground plane (206). In one embodiment, each antenna comprises respective control elements (293, 294). By controlling each control element (293, 294) to exhibit ON-OFF characteristics, respective radiating elements comprising a top portion (201) of a respective antenna can be turned OFF or ON in order to utilize one antenna or the other. Alternatively, if both control elements (293, 294) exhibit OFF characteristics, both antennas (282, 283) can be utilized to offer wider antenna coverage.

Figure 19A illustrates two capacitively loaded magnetic dipoles coupled in a back to back configuration to comprise an antenna (281). In one embodiment, a top portion (201) of antenna (281) is coupled to a bottom portion (203) by a vertical portion that comprises a control element (2101), which is electrically connected to top portion (201) at one end and to bottom portion (203) at another end. In one embodiment, wherein control element (2101) exhibits ON characteristics, the antenna (281) LC characteristics are defined by parallel capacitance and inductance of generally defined by the capacitive (204) and inductive (205) areas. With a control element that exhibits OFF characteristics, it has been identified that antenna (281) resonates at a lower frequency and a wider area of coverage and bandwidth.

Figure 19B illustrates another configuration of two capacitively loaded magnetic dipoles coupled to comprise an antenna (280). In one embodiment, a top portion (201) of antenna (281) is coupled to a bottom portion (203) by a vertical portion that comprises a control element (2101), which is electrically connected to top portion (201) at one end and to bottom portion (203) at another end. In the illustrated embodiment, top radiating portions (201) of antenna (280) are orthogonal rather than in the same plane, which provides polarization diversity in the radiation pattern provided by the radiating portions.

Figure 20 illustrates a 3D antenna (279) comprised of multiple capacitively loaded magnetic dipole antennas. In one embodiment, individual dipole antennas share common areas with one or more control elements placed in the capacitive area, inductive area, matching area, and/or stub area of one or more of the dipole structures, for example, control elements (231, 241, 251, 271). Such a complex structure effectuates coverage of multiple frequency band and provides the most optimized solution in terms of input impedance, radiated power and beam direction. In one embodiment, multiple capacitively magnetic dipole antennas can be arranged

to offer selection of a different configuration solutions in real time. For example, in one embodiment, wherein the human body influences reception or transmission of a wireless communications, one or more antennas could be actively substituted for other antennas to improve the real time reception or transmission of a communication.

It will be recognized the preceding description embodies an invention that may be practiced in other specific forms without departing from the spirit and essential characteristics of the disclosure. Thus, it is understood that the invention is not to be limited by the foregoing illustrative details, but rather is to be defined by the appended claims.

Figures 21a, 21b, and 21c illustrate respective three-dimensional, side, and bottom views of one or more portion of a capacitively loaded magnetic dipole antenna (399). In one embodiment, antenna (399) comprises a top portion (306) disposed opposite a ground plane portion (312), with the top portion coupled to the ground plane portion by a ground connection portion (307). In one embodiment, a generally planar disposition of the top portion (306) and an opposing generally planar disposition of the ground portion (312) define a first gap area (317). In one embodiment, ground portion (312) is coupled to top portion (306) by ground connection portion (307) in an area indicated generally as feed area (313). In one embodiment, ground portion (312) comprises a ground plane. In one embodiment, within the feed area, a signal feed line portion (305) is coupled to the top portion (306). In one embodiment, the top portion (306) comprises a first portion (316) and a second portion (311), with the first portion coupled to the second portion by a connection portion (314). In one embodiment, first portion (316) and second portion (311) are opposingly disposed in a plane and define a second gap area (315). In one embodiment, one or more portion (305), (307), (311), (312), (314), and (316) may comprise conductors. In one embodiment, one or more portion (305), (307), (311), (312), (314), and (316) may comprise conductive flat plate structures. It is understood, that top portion (306) and ground plane (312) may comprise other than flat-plate structures. For example, one or more portion (305), (307), (311), (312), (314), and (316) may comprise rods, cylinders, etc. It is also understood that the present invention is not limited to the described geometries, as in other embodiments the top portion (306), the ground plane (312), the first portion (316), and the second portion (311) may be disposed relative to each other in other geometries. For example, top conductor (306) may be coupled to ground plane portion (312), and first portion (316) may be coupled to second portion (311) such that one or more of the portions are in other than parallel

relationships. Thus, it is understood that antenna (399), as well as other antennas described herein, may vary in design and yet remain within the scope of the claimed invention. As will be understood with reference to the foregoing Description and Figures, one or more of portions (305), (307), (311), (312), (314), and (316), as well as other described further herein, may be utilized to effectuate changes in the operating characteristics of a capacitively loaded magnetic dipole antenna. In one embodiment, one or more of portions (305), (307), (311), (312), (314), and (316) may be utilized to alter the capacitive and/or inductive characteristics of a capacitively loaded magnetic dipole antenna design. For example, one or more of portions (305), (307), (311), (312), (314), and/or (316) may be utilized to reconfigure impedance, frequency, and/or radiation characteristics of a capacitively loaded magnetic dipole antenna.

Figures 22a and 22b illustrate respective side and bottom views of one or more portion of a capacitively loaded magnetic dipole antenna (398), wherein antenna (398) further comprises a control portion (321). In one embodiment, control portion (321) is disposed generally within the feed area (313). In one embodiment, control portion (321) is electrically coupled at one end to the feed line portion (305) and at another end to ground connection portion (307). In one embodiment, control portion (321) comprises a device that may exhibit ON-OFF and/or actively controllable capacitive/inductive characteristics. In one embodiment, control portion (321) may comprise a transistor device, a FET device, a MEMs device, or other suitable control portion or circuit capable of exhibiting ON-OFF and/or actively controllable capacitive/inductive characteristics. It has been identified that control portion (321), as well as other control portions described further herein, may be implemented by those of ordinary skill in the art and, thus, control portion (321) is described herein only in the detail necessary to enable one of such skill to implement the present invention. In one embodiment wherein the control portion (321) comprises a switch with ON characteristics, a Smith Chart loop, as used by those skilled in the art for impedance matching, is smaller than when the control portion (321) exhibits OFF characteristics. It has been identified that use of a control portion (321) with ON characteristics in the feed area (313) may be used to actively compensate for external influences on the antenna (398), for example, as by a human body. In one embodiment, wherein the capacitance/inductance of control portion (321) may be actively changed, for example, by a control input to a connection of a FET device or circuit connected between feed line (305) and connector portion (307), the control portion (321) may be used to effectuate changes in the

inductance or capacitance of the antenna (398). It has been identified that the capacitance/inductance of the control portion (321) may be varied to actively change the LC characteristics of antenna (398) such that the impedance and/or resonant frequency of the antenna (398) may be actively re/configured.

Figures 23a, 23b, and 23c illustrate respective three dimensional, side sectional, and bottom views of one or more portions of a capacitively loaded magnetic dipole antenna (397), wherein antenna (397) further comprises a control portion (331). In one embodiment, control portion (331) is disposed in an area generally defined by connection portion (314). In the one embodiment, connection portion (314) comprises a first part (314a) coupled to a second part (314b). In one embodiment, first part (314a) is coupled to second part (314b) by the control portion (331). In one embodiment, wherein the control portion (331) comprises a switch that exhibits ON characteristics, it is understood that the first and second parts of connection portion (314) may be electrically connected to each other to effectuate a larger surface geometry than in an embodiment wherein the control portion exhibits OFF characteristics.

It has been identified that with a control portion (331) coupled to connection portion (314) in a manner as generally described herein, a connection portion (314) may comprise a larger surface area and the resonant frequency of antenna (397) may thus be lowered. In one embodiment, the operating frequency of antenna (397) may be actively changed from one frequency to another, for example, between a 800MHz band used in the US and a 900MHz band used in Europe for cell-phone transmitting and receiving applications. In one embodiment, wherein the capacitance and/or inductance of the control portion (331) may be actively changed, for example, by a control input to a connection of a FET device or circuit connected between the first part (314a) and the second part (314b), it has also been identified that the capacitance and/or inductance of the control portion (331) may be varied to change the LC characteristics of antenna (397) such that the resonant frequency of the antenna (397) may be actively re/configured.

Figures 24a and 24b illustrate respective bottom and front-side-sectional views of one or more portions of a capacitively loaded magnetic dipole antenna (396), wherein antenna (396) further comprises a control portion (341) disposed in the general area of the second gap area (315). In one embodiment, control portion (341) is electrically coupled at one end to first portion (316) and at another end to second portion (311). In one embodiment, with a control portion (341) that exhibits ON characteristics, first portion (316) may be electrically coupled to second

portion (311) so as to increase the frequency and the bandwidth of the antenna (396), compared to an embodiment where the control portion (341) exhibits OFF characteristics. In one embodiment, wherein the capacitance and/or inductance of the control portion (341) may be actively changed, the electrical coupling between the first portion (316) and the second portion (311) may be continuously controlled to effectuate changes in the inductance and/or capacitance in the second gap area (315). It has been identified that with a control portion (341) disposed generally in the gap (315) area, the resonant frequency, the bandwidth, and/or the antenna impedance characteristics may be actively re/configured.

Figure 24c illustrates a front-side-sectional view of one or more portion of a capacitively loaded magnetic dipole antenna (396), wherein antenna (396) further comprises a bridge portion (344) and a control portion (341) disposed in the general area of the second gap area (315). In one embodiment, bridge portion (344) is coupled to the second portion (311) to extend an area of the second portion over the first portion (316). In one embodiment, the control portion (341) is coupled at one end to the bridge portion (344) and at another end to the first portion (316).

Figure 24d illustrates a front-side-sectional view of one or more portion of a capacitively loaded magnetic dipole antenna (396), wherein antenna (396) further comprises a bridge portion (344) and two control portions (341) disposed in the general area of the second gap (315). In one embodiment, bridge portion (344) is disposed to extend over an area of the first portion (316) and over an area of the second portion (311). Bridge portion (344) is coupled to the first portion (316) by a first control portion (341) and to the second portion (311) by a second control portion (341). It has been identified that the control portion(s) (341) of the embodiments illustrated by Figures 24c and 24d may be disposed of generally in the gap (315) area to effectuate active control of resonant frequency, bandwidth, and impedance characteristics of antenna (396).

Figures 25a and 25b illustrate respective three dimensional and bottom views of one or more portion of a capacitively loaded magnetic dipole antenna (395), wherein antenna (395) further comprises a control portion (351) disposed in the general area of the first portion (316). In one embodiment, first portion (316) comprises a first part (316a) and a second part (316b), with the first part coupled to the second part by the control portion (351). In one embodiment, control portion (351) is coupled at one end to first part (316a) and at another end to second part (316b) such that when control portion (351) exhibits ON characteristics, the area of first portion (316) may be effectively increased. It has been identified that with a control portion (351) that

exhibits ON characteristics, the resonant frequency of antenna (395) is lower than with a control portion (351) that exhibits OFF characteristics, for example, 800MHz vs. 900 MHz. It has also been identified with a control portion (351), wherein the capacitance and/or inductance may be changed, the resonant frequency of antenna (395) may be actively re/configured.

Figures 26a and 26b illustrate respective three dimensional and side views of one or more portion of a capacitively loaded magnetic dipole antenna (394), wherein antenna (394) further comprises a control portion (361) disposed generally in the first gap area (317) defined by the first portion (316) and the ground plane (312). It has been identified, wherein control portion (361) is coupled at one end to the first portion (316) and at another end to the ground plane (312), that when control portion (361) exhibits ON characteristics, the antenna (394) may be switched off. It has also been identified, wherein the capacitance and/or inductance of the control portion (361) may be actively changed, that the resonant frequency or impedance of antenna (394) may be actively re/configured.

Figure 27a illustrates resonant frequencies of a dual band capacitively loaded magnetic dipole antenna, wherein the antenna is provided with an additional resonant frequency by including one or more additional portion and/or gap in a low current density portion of the antenna. In one embodiment, a capacitively loaded magnetic dipole antenna may be provided with a lower resonant frequency (a) that spans an upper frequency band at its 3db point and an upper resonant frequency (b) that spans an upper frequency bank at its 3db point, both resonant frequencies separated in frequency by (X), and both resonant frequencies determined by the geometry of one or more portion and/or gap as described further herein. In different embodiments it is possible to actively re/configure antenna characteristics in either their upper frequency band or their lower frequency band, or both, by disposing control portions in accordance with principles set out forth in the descriptions provided further herein.

Figure 27b illustrates a bottom view of one or more portion of a dual band capacitively loaded magnetic dipole antenna (393), wherein antenna (393) comprises a control portion (not shown) disposed in one or more of area (373), area (374), area (375), area (376), area (3714), and area (3715). It is understood that although Figures 27a-d describe embodiments wherein one additional portion and/or additional gap are included to comprise a dual band antenna, the present invention is not limited to these embodiments, as in other embodiments more than one additional portion and/or more than one additional gap may be provided to effectuate creation of

one or more additional resonant frequency in a capacitively loaded magnetic dipole antenna. The embodiment of Figure 27b is similar to the embodiment of Figure 21a, but further comprises a third portion (377). In one embodiment, the third portion (377) is coupled to a connection portion (314), and is disposed between a first portion (316) and a second portion (311). The third portion (377) enables antenna (393) to operate at two different resonant frequencies separated in frequency by (X). It is understood that when (X) approaches zero, changes made to affect antenna characteristics at one resonant frequency may affect characteristics at another resonant frequency. It has been identified that a control portion used in area (373) may be used to control the impedance of the antenna (393) in both resonant frequency bands. The areas (374, 375) provide similar function to that of the respective portion and gap (314, 315) of the single band antenna of Figure 21 for a lower resonant frequency band. A control portion coupled to antenna (393) in area (376) may be used to affect characteristics of the antenna (393) in both lower and upper resonant frequency bands. Finally, it has been identified that the areas (3714, 3715) act to affect an upper resonant frequency band in a manner similar to the portion and gap (314, 315) of the single band antenna of Figure 21.

Figure 27c illustrates a bottom view of one or more portion of a dual band capacitively loaded magnetic dipole antenna (392), wherein antenna (392) comprises a control portion (not shown) disposed in one or more of area (373), area (374), area (375), area (376), area (3715), and area (3716). The embodiment of Figure 27c is similar to the embodiment of Figure 21, but further comprises a third portion (377). In one embodiment, the third portion (377) is coupled to the first portion (316), and is disposed between first portion (316) and second portion (311). The third portion (377) enables antenna (392) to operate at one or both of an upper and lower resonant frequency. It has been identified that a control portion may be used in area (373) to control the impedance of the antenna (392) in either the lower or the upper frequency band. The areas (374, 375, 376) provide similar function to that of respective gap and portions (314, 315, 316) of the single band antenna of Figure 21 for a lower frequency band. It has been identified that the influence of area (376) over an upper frequency band is reduced. It has also been identified that the areas (3715, 3716) act to affect an upper frequency band in a manner similar to the gap and portion (315, 316) of the single band antenna of Figure 21. Finally, it has also been identified that characteristics of the antenna (392) may be altered in an lower frequency band independent of the characteristics in an upper frequency band.



Figure 27d illustrates a bottom view of one or more portion of a dual band capacitively loaded magnetic dipole antenna (391), wherein antenna (391) comprises a control portion (not shown) disposed in one or more of area (373), area (374), area (375), area (376), area (3715), and area (3716). The embodiment of Figure 27d is similar to the embodiment of Figure 21, but further comprises a third portion (377). In one embodiment, the third portion (377) is disposed between a first portion (316) and a second portion (311). Third portion (377) is coupled at one end to the first portion (316) by a first connection portion and at a second end to the second portion (311) by a second connection portion. The third portion (377) enables antenna (391) to operate in one or both of two different resonant frequency bands. It has been identified that a control portion may be used in area (373) to control the impedance of the antenna (391) in either a lower or upper frequency band. The areas (374, 375, 376) provide similar function to that of respective gap and portions (314, 315, 316) of the single band antenna of Figure 21 for a lower frequency band. It has been identified that the influence of area (376) over an upper frequency band is reduced. It has also been identified that the areas (3715, 3716) act to affect an upper frequency band in a manner similar to the gap and portion (315, 316) of the single band antenna of Figure 21. Finally, it has also been identified that characteristics of the antenna (391) may be altered in a lower frequency band independent of the characteristics in an upper frequency band.

Figure 28a illustrates a three-dimensional view of one or more portion of a capacitively loaded magnetic dipole antenna (390), wherein antenna (390) further comprises a stub (381). It has been identified that with a stub (381) coupled to an antenna in the feed area (313), for example, to a ground connection portion (307) (not illustrated) or to a feed line (305), a gap may be defined between the stub and a portion of the antenna such that an additional lower or upper antenna resonant frequency is created. By changing characteristics of the stub as described herein, it is possible to control an antenna's characteristics, for example, its impedance and lower/upper resonant frequency. In one embodiment, stub (381) comprises a printed line disposed on ground plan portion (312) and defines a gap between the stub and one or more portion of antenna (390). In one embodiment, stub (381) comprises a right angle geometry, but it is understood that stub (381) may comprise other geometries, for example straight, curved, etc. In one embodiment, stub (381) may be implemented with various technologies, for example, technologies used to create micro-strip lines or coplanar-waveguides as practiced by those skilled

in the art. In one embodiment, stub (381) impedance measures 50 ohms, but other impedances are also within the scope of the present invention.

Figure 28b illustrates a three-dimensional view of one or more portion of a capacitively loaded magnetic dipole antenna (389), wherein antenna (389) further comprises a stub (382) coupled to a ground connection portion (307) (not illustrated) or to a feed line (305). In one embodiment, stub (382) is disposed above the ground plane portion (312) and below one or more portions of antenna (389). In one embodiment, stub (382) may be disposed in such a way to couple directly to portion (311). In one embodiment, stub (382) comprises a right angle geometry, but it is understood that stub (382) may comprise other geometries, for example straight or curved.

Figure 29a illustrates a three-dimensional view of one or more portion of a capacitively loaded magnetic dipole antenna (388) similar to that illustrated by Figure 28a, wherein antenna (388) comprises a stub (381) and a control portion (391). In one embodiment, control portion (391) is disposed to couple a first portion (381a) to a second portion (381b) of stub (381). It has been identified that a control portion (391) that exhibits ON characteristics may be utilized to increase the length of stub (381), as compared to a control portion that exhibits OFF characteristics. It is identified that control portion (391) may thus enable control of an antenna resonant frequency created by the stub. It has also been identified that if the resonant frequency created by stub (381) is sufficiently close to the resonant frequency created by the top portion (306), control portion (391) may be used to effectuate changes in the resonant frequency or antenna characteristics created by the top portion.

Figure 29b illustrates a three-dimensional view of one or more portion of a capacitively loaded magnetic dipole antenna (387) similar to that illustrated by Figure 28b, wherein antenna (387) comprises a stub (381) and control portion (391). In one embodiment, control portion (391) is disposed to couple stub (381) to the ground plane (312). It is identified that use of control portion (391) may thus enable control of an antenna resonant frequency created by the stub. It has also been identified that if the resonant frequency created by stub (381) is sufficiently close to the resonant frequency created by the top portion (306), control portion (391) may be used to effectuate changes in the resonant frequency or antenna characteristics created by the top portion.

Figure 30a illustrates a three-dimensional view of one or more portion of a capacitively loaded magnetic dipole antenna (386) similar to that illustrated by Figure 28b, wherein the antenna comprises a stub (382) and further comprises a control portion (3101) disposed to couple one part of the stub to another part of the stub. It has been identified that control portion (3101) may be used to effectuate changes in the electrical length of a stub (382). It is identified that use of a control portion (3101) may thus enable control of an antenna resonant frequency created by the stub. It has also been identified that if the resonant frequency created by stub (3101) is sufficiently close to the resonant frequency created by the top portion (306), control portion (3101) may be used to effectuate changes in the resonant frequency or antenna characteristics created by the top portion.

Figure 30b illustrates a three-dimensional view of one or more portion of a capacitively loaded magnetic dipole antenna (385) similar to that illustrated by Figure 28b, wherein the antenna comprises a stub (382) and further comprises a control portion (3101) coupled to connect the stub (382) to portion (306) of antenna (385). It is identified that control portion (3101) may be used to effectuate active control of characteristics of antenna (385).

Figure 30c illustrates a three-dimensional view of one or more portion of a capacitively loaded magnetic dipole antenna (384) similar to that illustrated by Figure 28b, wherein the antenna comprises a stub (384) and a control portion (3101) connected between the stub and a ground point (3102) on the ground plane portion (312). It has been identified that the influence of the stub on the characteristics of the antenna is more drastic when the control portion (3101) exhibits ON characteristics than when the control portion exhibits OFF characteristics.

It is identified that capacitively loaded magnetic dipole antennas may comprise more than one control portion to effectuate independent control of one or more characteristics of a capacitively loaded magnetic dipole antenna, for example independent control of multiple resonant frequencies of a multiple band antenna.

Figure 31A illustrates a three-dimensional view of one or more portion of a dual band capacitively loaded magnetic dipole antenna (383), comprising a control portion (3111), a control portion (3112), a reconfigurable area (314) similar to that described by Figure 23c, and a third portion (3113) similar to that described by Figure 27b. In one embodiment, antenna (383) may further comprise a reconfigurable stub (382) similar to that described by Figure 20a. It has been identified that control portion (3111) has influence over a lower resonant frequency band.

For example, by controlling the characteristics of control portion (3111) it is possible to switch the antenna (383) from 800MHz to 900MHz. It has also been identified that control portion (3112) on the stub (382) may be used to influence an upper resonant frequency band. For example, it is possible to switch antenna (383) from 1800MHz to 1900MHz.

Wireless communication devices operating in one or more of frequency bands ( such as but not limited to 450MHz, 800MHz, 900MHz, 1.575GHz, 1.8GHz, 1.9GHz, 2GHz, 2.5GHz, 5GHz) and utilizing one or more embodiments described herein are considered to be within the scope of the invention, for example, PDA's, cell phones, etc. Other frequency bands are also considered to be within the scope of the present invention.

Thus, it will be recognized that the preceding description embodies one or more invention that may be practiced in other specific forms without departing from the spirit and essential characteristics of the disclosure and that the invention is not to be limited by the foregoing illustrative details, but rather is to be defined by the appended claims.

CLAIMS

WE CLAIM:

1. An antenna element, comprising:  
a bottom plate;  
a top section positioned above the bottom plate and having at least one cutout therein, the top section being positioned substantially parallel to the bottom plate; and  
one or more tongues extending from an edge of the at least one cutout.
2. The antenna element according to claim 1, wherein the tongues are coplanar with the top section.
3. The antenna element according to claim 1, wherein the tongues are positioned below a plane of the top section, the tongues including a vertical extension connecting a horizontal tongue portion to the top section.
4. The antenna element according to claim 3, wherein the vertical extension is substantially perpendicular to the top section.
5. The antenna element according to claim 1, wherein each cutout has a substantially rectangular configuration.
6. The antenna element according to claim 1, wherein the top section includes a single cutout.
7. The antenna element according to claim 6, wherein the single cutout is provided with a single tongue.
8. The antenna element according to claim 6, wherein the single cutout is provided with a plurality of tongues.
9. The antenna element according to claim 8, wherein each of the plurality of tongues extends from the same edge of the cutout.
10. The antenna element according to claim 8, wherein the plurality of tongues includes tongues extending from the different edges of the cutout.
11. An antenna element assembly, comprising:  
a base section having a bottom plate and a top section positioned above the bottom plate, the top section having a module-receiving opening therein; and  
a tongue module adapted to be accommodated within the module-receiving opening, the tongue module comprising:  
a top surface with at least one cutout therein; and

one of more tongues extending from an edge of the at least one cutout.

12. The antenna element assembly according to claim 11, wherein the module-receiving opening is substantially rectangular and is located in a central region of the top section.

13. The antenna element assembly according to claim 11, wherein the cutout is substantially rectangular.

14. The antenna element assembly according to claim 11, wherein the module-receiving opening is U-shaped.

15. The antenna element assembly according to claim 14, wherein the tongue module includes a vertical flap extending downward from an edge of the top surface.

16. A device, comprising:

a plurality of portions, the plurality of portions coupled to define a capacitively loaded dipole antenna; and

at least one active control element, wherein the at least one control element is coupled to one or more of the portions.

17. The device of claim 16, wherein one or more of the plurality of portions define a capacitive area, and wherein at least one control element is disposed generally in the capacitive area.

18. The device of claim 16, wherein one or more of the plurality of portions define an inductive area, and wherein at least one control element is disposed generally in the inductive area.

19. The device of claim 16, wherein one or more of the plurality of portions define a feed area, and wherein at least one control element is disposed generally in the feed area.

20. The device of claim 16, wherein the plurality of portions comprise a top portion, a middle portion, a bottom portion; wherein the top portion is coupled to the bottom portion; wherein the bottom portion is coupled to the middle portion, and wherein the middle portion is disposed generally between the top portion and the bottom portion.

21. The device of claim 20, wherein the top portion and the middle portion generally define a capacitive area, wherein the middle portion and the bottom portion generally define an inductive area.

22. The device of claim 20, wherein at least one control element is disposed in the capacitive area.

23. The device of claim 20, wherein at least one control element is disposed in the inductive area.

24. The device of claim 20, wherein the at least one control element is coupled to the top portion and to the middle portion.
25. The device of claim 20, wherein the at least one control element is coupled to the middle portion and to the bottom portion.
26. The device of claim 20, wherein the at least one control element is disposed to couple the top portion to the bottom portion.
27. The device of claim 20, wherein the at least one control element is disposed to couple the bottom portion to the middle portion.
28. The device of claim 16, wherein the one or more control element comprises a switch.
29. The device of claim 16, wherein the one or more control element exhibits active capacitive or inductive characteristics.
30. The device of claim 16, wherein the one or more control element comprises a transistor device.
31. The device of claim 16, wherein the one or more control element comprises a FET device.
32. The device of claim 16, wherein the one or more control element comprises a MEMS device.
33. The device of claim 16, wherein the device further comprises a wireless communications device, a feed, and a ground; and wherein the wireless communications device is coupled to the antenna through the feed and the ground.
34. An antenna comprising:  
a ground plane;  
a first conductor having a first length extending generally longitudinally above the ground plane and having a first end electrically connected to the ground plane at a first location;  
a second conductor having a second length extending generally longitudinally above the ground plane, the second conductor having a first end electrically connected to the ground plane at a second location;  
an antenna feed coupled to the first conductor; and  
a first active component, the first active component comprising a control input, wherein an input to the control input enables characteristics of the antenna to be configured.
35. The antenna of claim 34 wherein the first and second conductors overlap in an area to form a gap, wherein the first active component is disposed in the gap.

36. The antenna of claim 34 wherein the first conductor or the second conductor comprise the first active component.
37. The antenna of claim 34 wherein the first active component is disposed between the second conductor and the ground plane.
38. The antenna of claim 34 wherein the first active component is disposed between the first conductor and the ground plane.
39. The antenna of claim 34 wherein the first active component is disposed between the feed and the ground plane.
40. The antenna of claim 34 further comprising a first stub coupled to the feed.
41. The antenna of claim 40 wherein the first stub comprises the first active component.
42. The antenna of claim 40 wherein the first active component is disposed between the first stub and the ground plane.
43. The antenna of claim 40 further comprising a second stub and a second active component, wherein the first stub comprises the first active component, and wherein the second active component is coupled between the second stub and the ground plane.
44. A device, comprising:  
a ground plane, the ground plane comprising a first side and a second side;  
a first capacitively loaded dipole antenna; and  
a second capacitively loaded dipole antenna, wherein the first antenna is coupled to a first side of the ground plane, and wherein the second antenna is coupled to a second side of the ground plane.
45. The device of claim 44, further comprising a first active component, the first active component comprising a first control input, wherein an input to the first control input enables characteristics of the first antenna to be configured; and a second active component, the second active component comprising a second control input, wherein an input to the second control input enables characteristics of the second antenna to be configured.
46. A capacitively loaded magnetic dipole antenna, comprising: control means for actively controlling characteristics of the antenna.
47. A method for actively controlling characteristics of a capacitively loaded dipole antenna comprising the steps of:  
providing a capacitively loaded dipole antenna;  
providing a control element, the control element coupled to the antenna;  
providing an input to the control element; and



controlling the characteristics of the antenna with the input.

48. A wireless communications device comprising:

a multiple band capacitively coupled dipole antenna; the antenna including one or more antenna characteristic, a ground portion, a conductor coupled to the ground portion and disposed in an opposing relationship to the ground portion, and a control portion coupled to the antenna to enable active reconfiguration of the one or more antenna characteristic.

49. An antenna comprising:

one or more antenna characteristic;  
a ground portion;

a conductor coupled to the ground portion, the conductor disposed in an opposing relationship to the ground portion; and

a control portion coupled to the antenna to enable active reconfiguration of the one or more antenna characteristic.

50. The antenna of claim 49, wherein the conductor comprises a plurality of conductor portions, and wherein the control portion is coupled between two of the conductor portions.

51. The antenna of claim 49, wherein the conductor comprises a plurality of conductor portions, wherein one or more gap is defined by the conductor portions, and wherein the control portion is disposed in a gap defined by two of the conductor portions.

52. The antenna of claim 49, wherein the control portion is disposed in a gap defined by the ground portion and the conductor, and wherein the control portion is coupled to the ground portion and the conductor.

53. The antenna of claim 49, further comprising a stub, wherein the stub comprises one or more stub portion, and wherein at least one stub portion is coupled to the conductor portion.

54. The antenna of claim 53, wherein a first end of a control portion is coupled to one stub portion and a second end of a control portion is coupled to a second stub portion.

55. The antenna of claim 53, wherein a first end of a control portion is coupled to one stub portion and a second end of a control portion is coupled to the ground portion.

56. The antenna of claim 53, wherein a first end of a control portion is coupled to one stub portion and a second end of a control portion is coupled to the conductor.

57. The antenna of claim 53, wherein the conductor comprises a plurality of conductor portions, and wherein a control portion is coupled between two of the conductor portions.

58. The antenna of claim 54, wherein the conductor comprises a plurality of conductor portions, and wherein a control portion is coupled between two of the conductor portions.

59. The antenna of claim 49, wherein the control portion comprises a switch.
60. The antenna of claim 49, wherein the control portion exhibits active capacitive or inductive characteristics.
61. The antenna of claim 49, wherein the control portion comprises a transistor device.
62. The antenna of claim 49, wherein the control portion comprises a FET device.
63. The antenna of claim 49, wherein the control portion comprises a MEMs device.
64. The antenna of claim 50, wherein the ground portion and the plurality of conductor portions are coupled to define a capacitively coupled magnetic dipole antenna.
65. The antenna of claim 53, wherein the stub is disposed on the ground portion.
66. The antenna of claim 53, wherein the stub is disposed between the ground portion and the conductor.
67. The antenna of claim 17, wherein the antenna comprises a multiple band antenna.
68. A device comprising:  
  
an antenna; the antenna comprising one or more antenna characteristic, a ground portion, a conductor coupled to the ground portion and disposed in an opposing relationship to the ground portion, and a control portion coupled to the antenna to enable active configuration of the one or more antenna characteristic.
69. The antenna of claim 68, wherein the conductor comprises a plurality of conductor portions, and further comprising a stub, wherein the stub comprises one or more stub portion, and wherein a stub portion is coupled to one of the conductor portions.
70. The antenna of claim 69, wherein the control portion is coupled to a conductor portion.
71. The antenna of claim 69, wherein the control portion is coupled to a stub portion.
72. The antenna of claim 68, wherein the control portion comprises a switch.
73. The antenna of claim 68, wherein the control portion exhibits active capacitive or inductive characteristics.
74. The antenna of claim 68, wherein the control portion comprises a transistor device.
75. The antenna of claim 68, wherein the control portion comprises a FET device.
76. The antenna of claim 68, wherein the control portion comprises a MEMs device.
77. The antenna of claim 69, wherein the ground portion and the plurality of conductor portions are coupled to define a capacitively coupled magnetic dipole antenna.

78. A method for actively controlling characteristics of a multiple-band capacitively coupled dipole antenna comprising the steps of:

providing a capacitively loaded dipole antenna, the antenna comprising one or more characteristic;

coupling a control portion to the antenna;

providing an input to the control portion; and

controlling the one or more characteristic with changes to the input

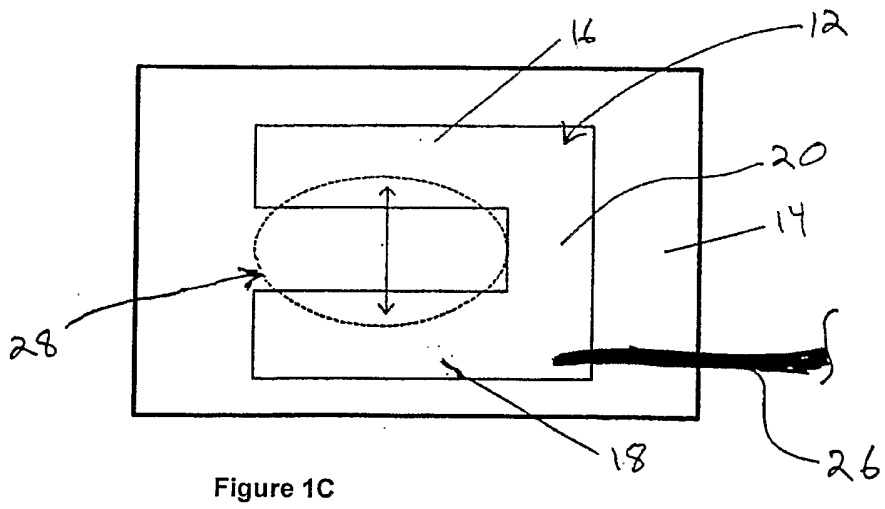
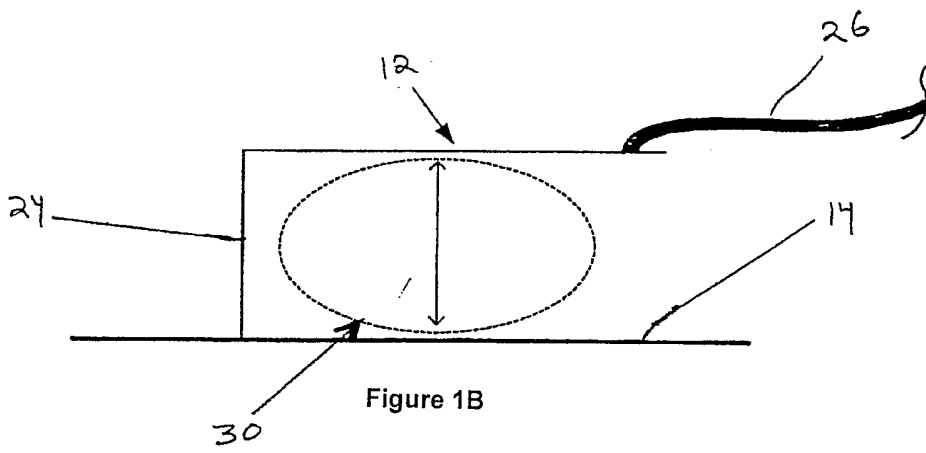
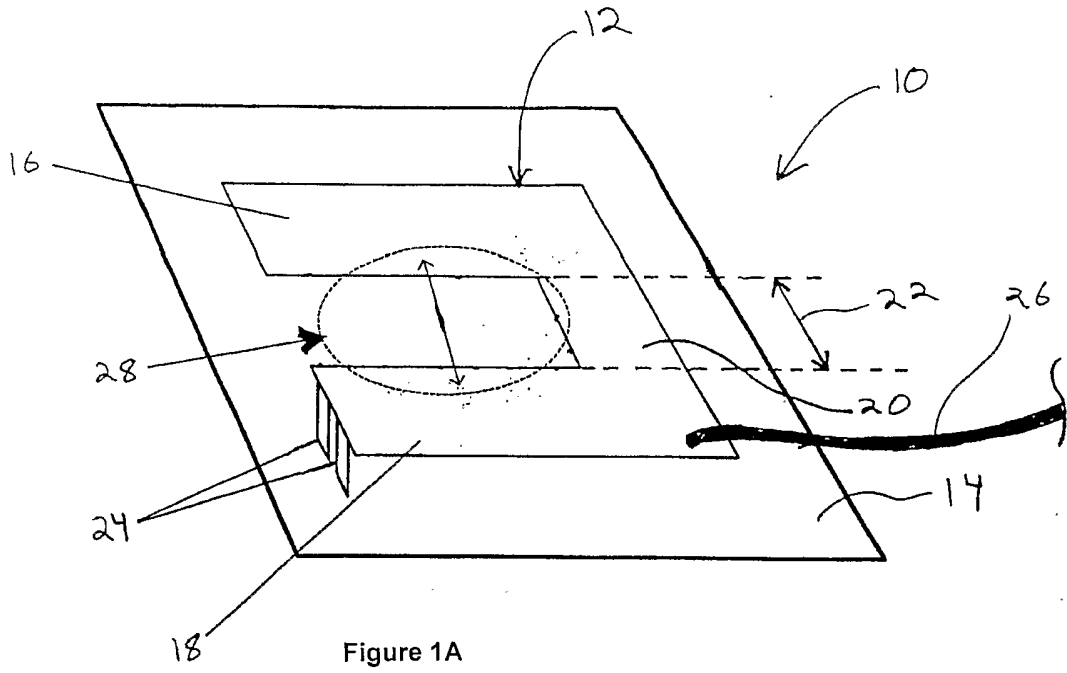

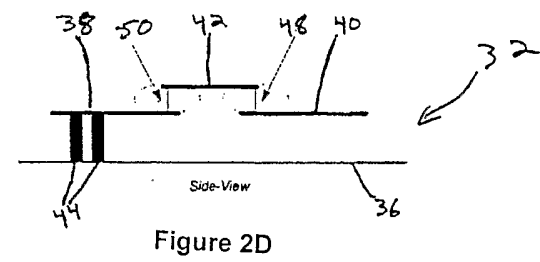
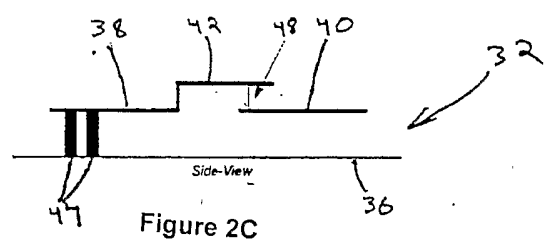
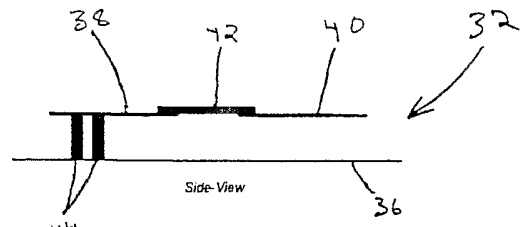
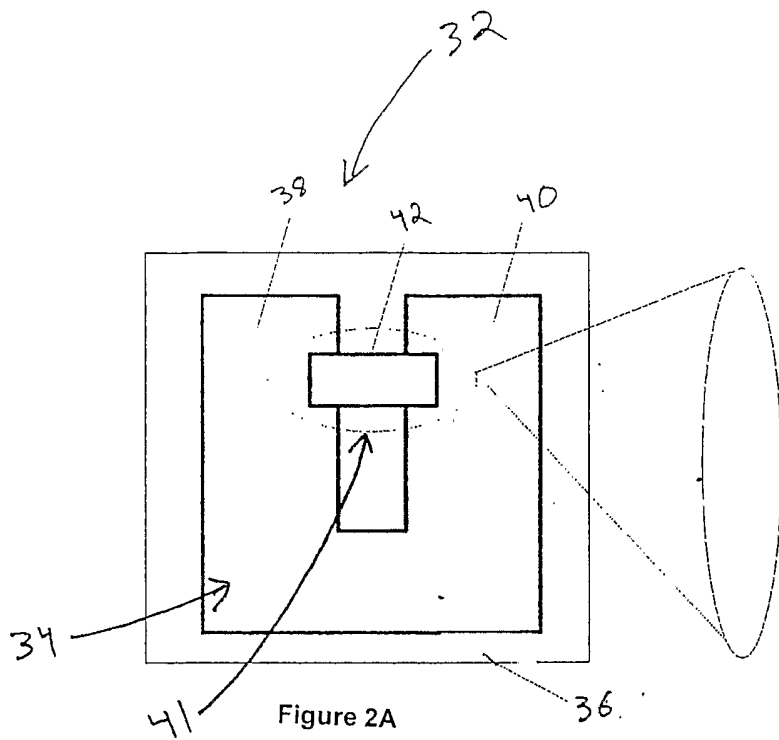

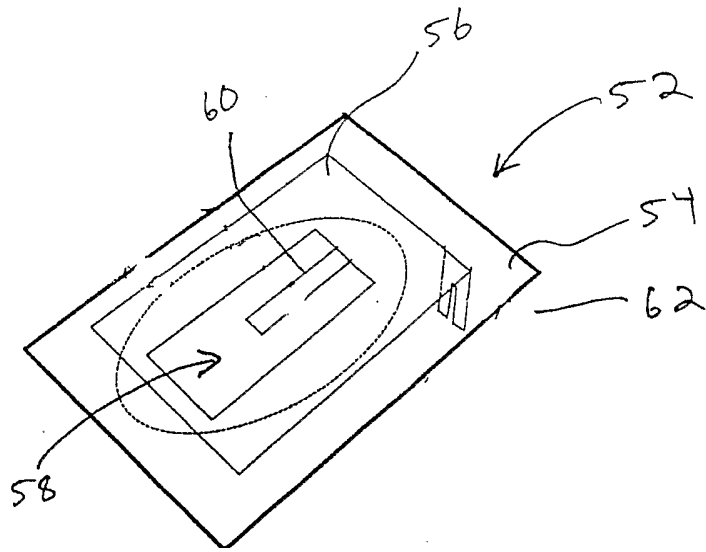

Figure 3A

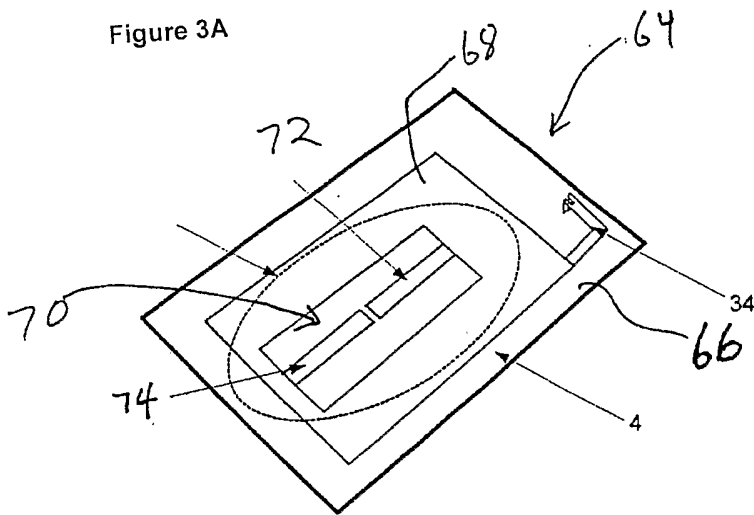

Figure 3B

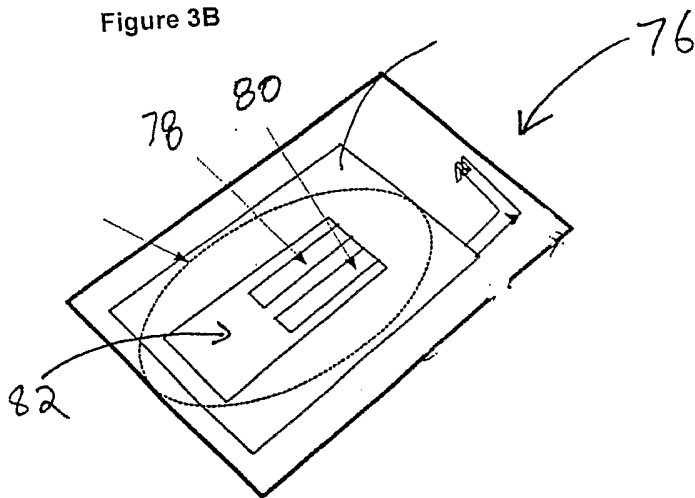

Figure 3C

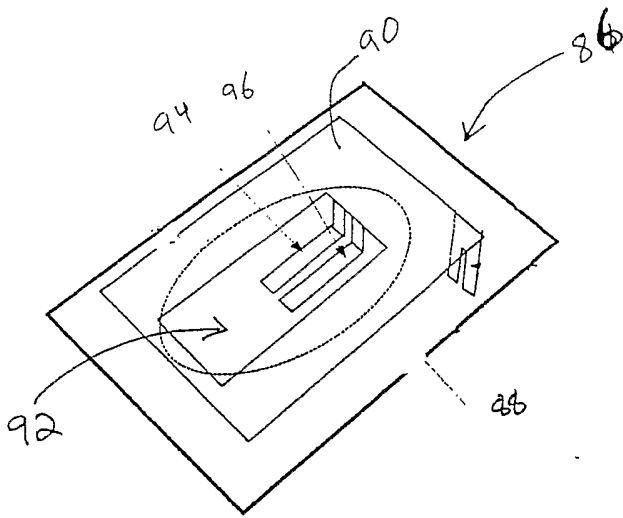

Figure 4A

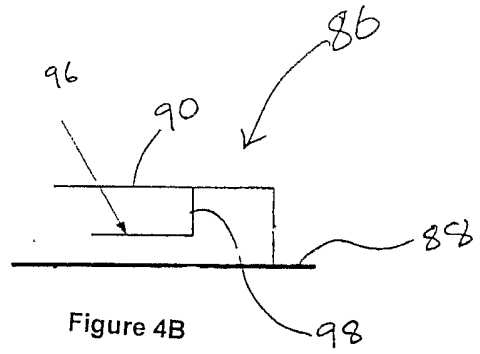

Figure 4B

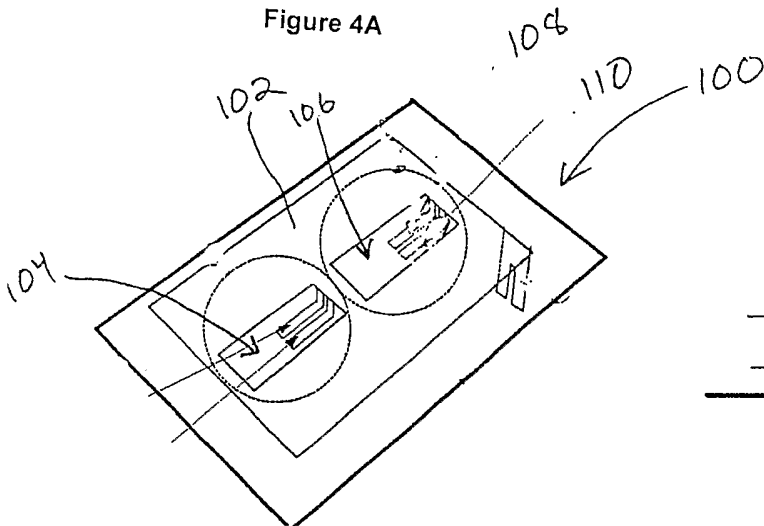

Figure 4C

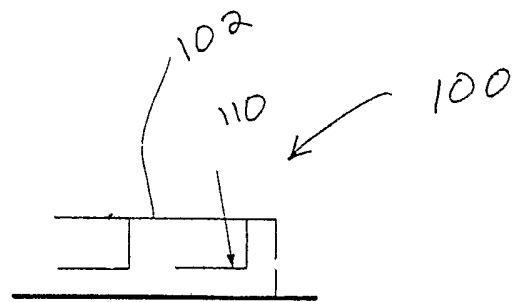

Figure 4D

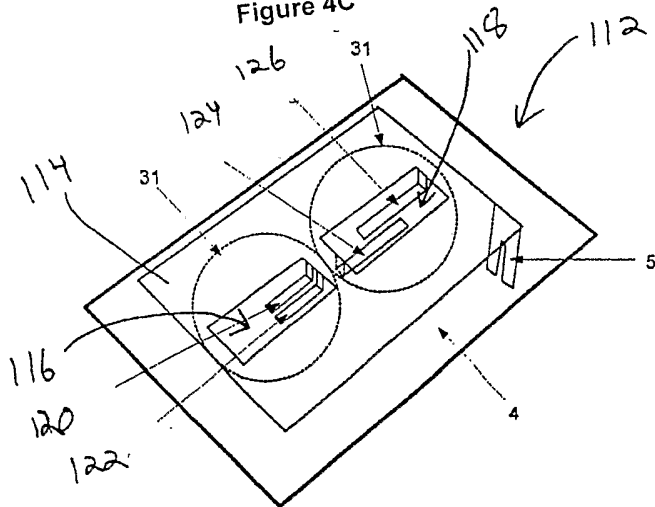

Figure 4E

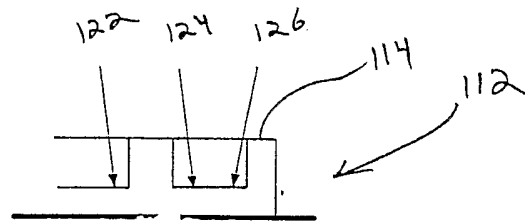

Figure 4F

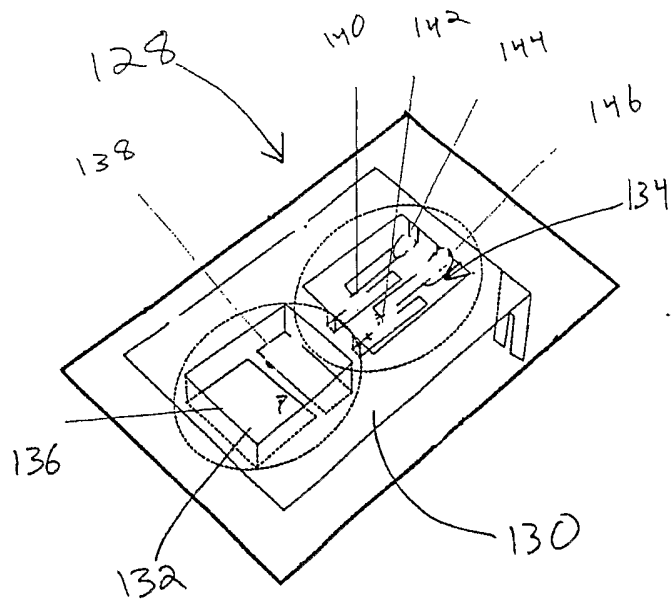

Figure 5A

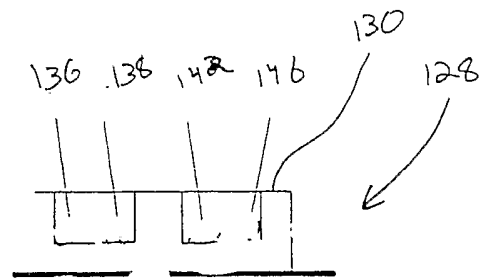

Figure 5B



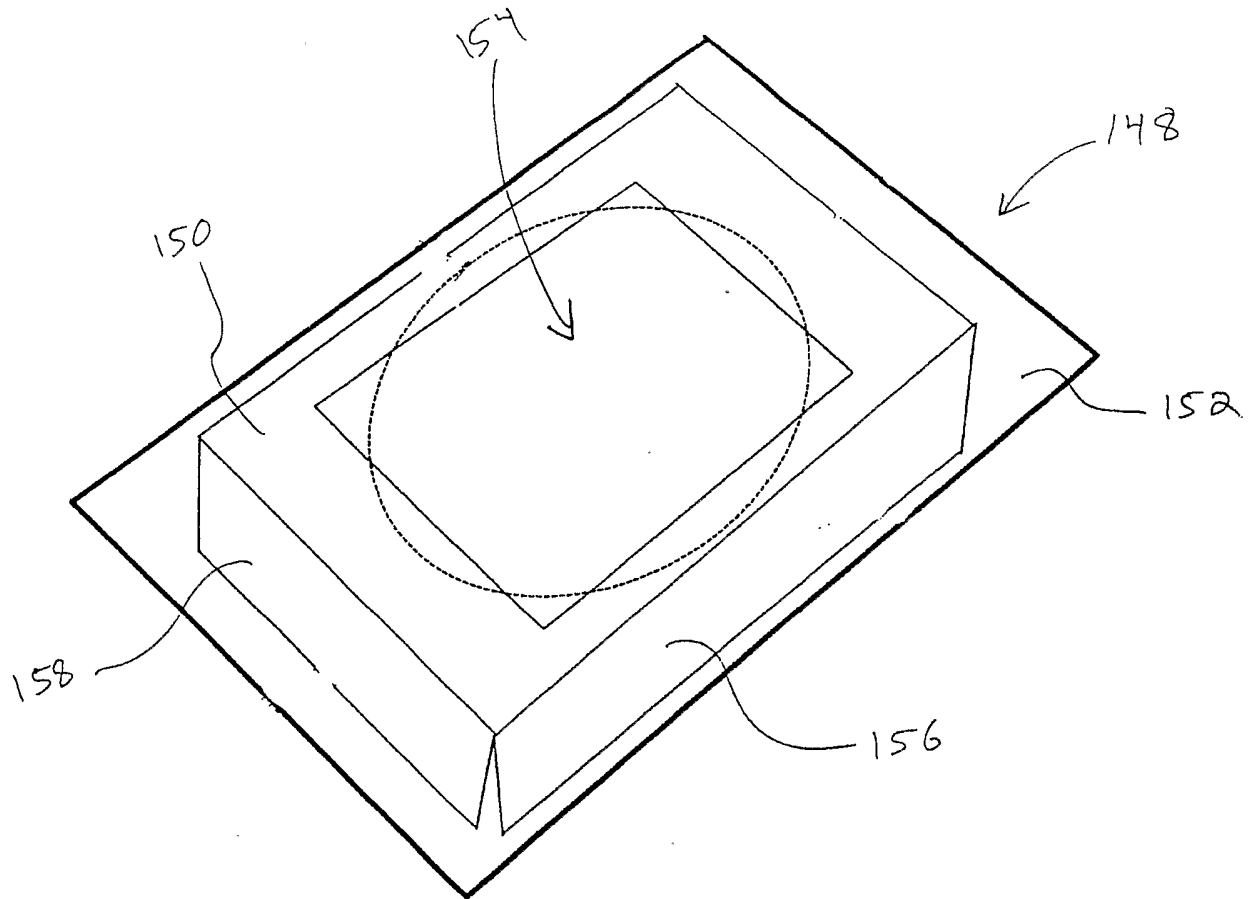
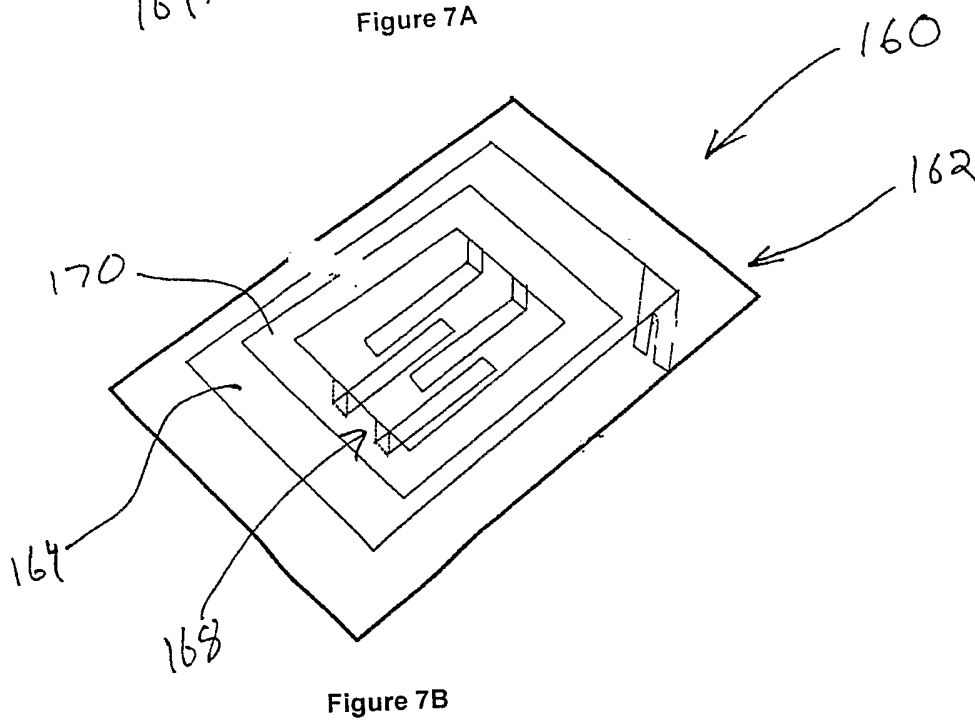
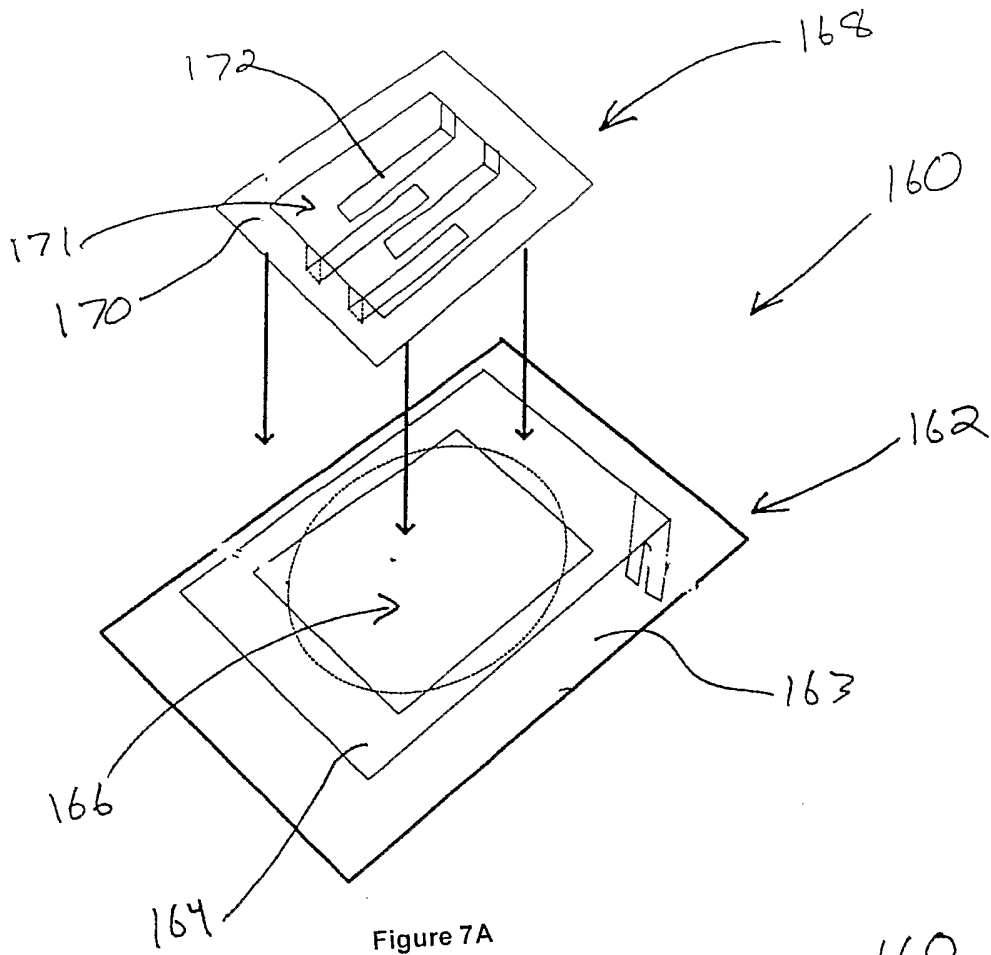

Figure 6



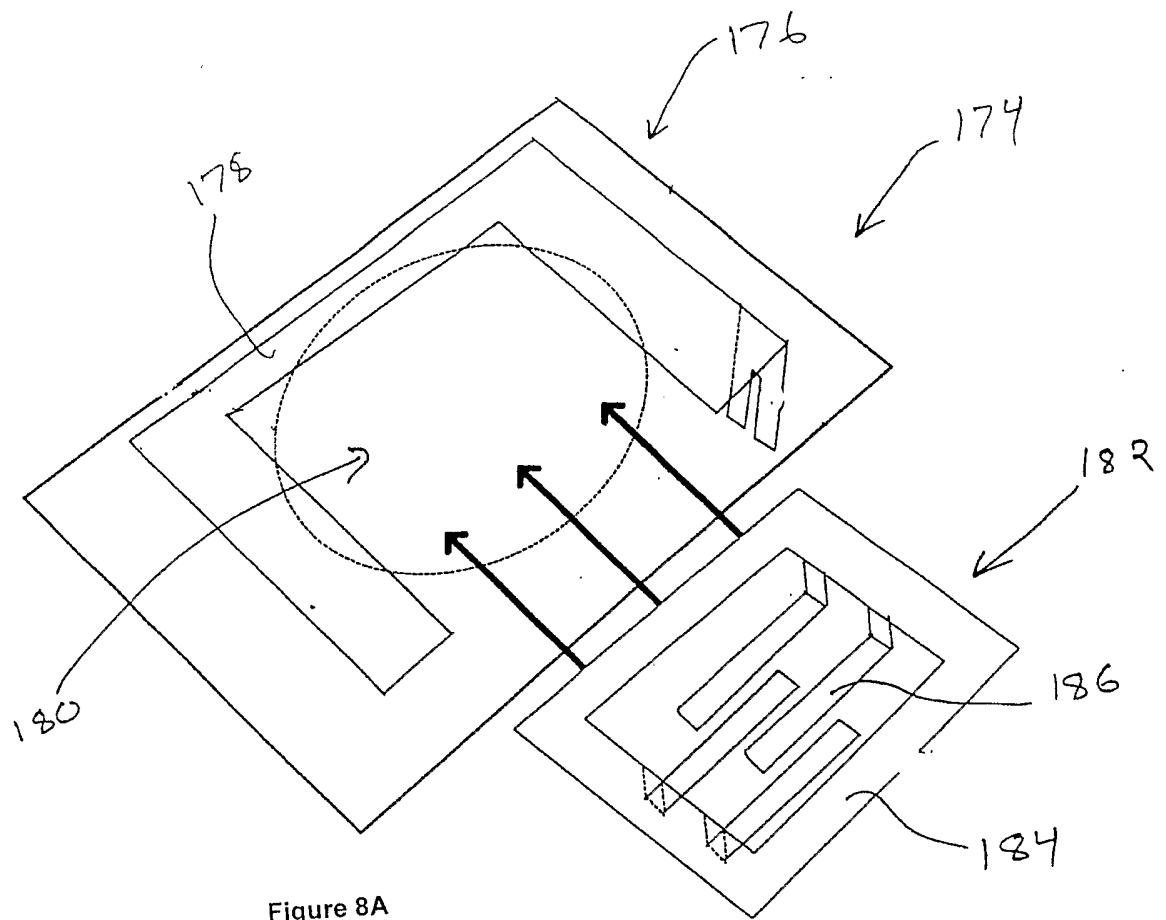

Figure 8A

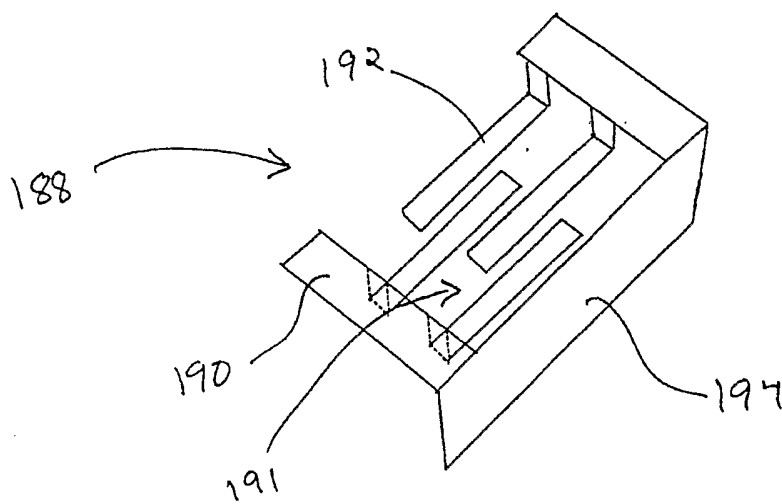

Figure 8B

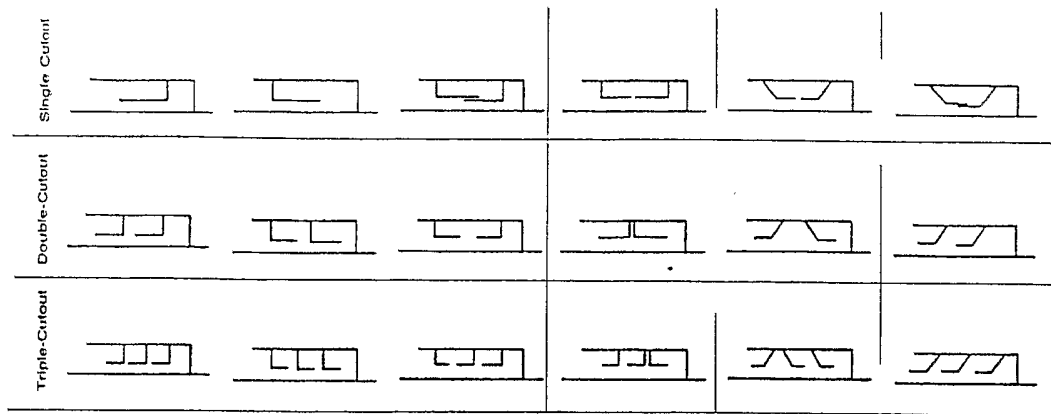
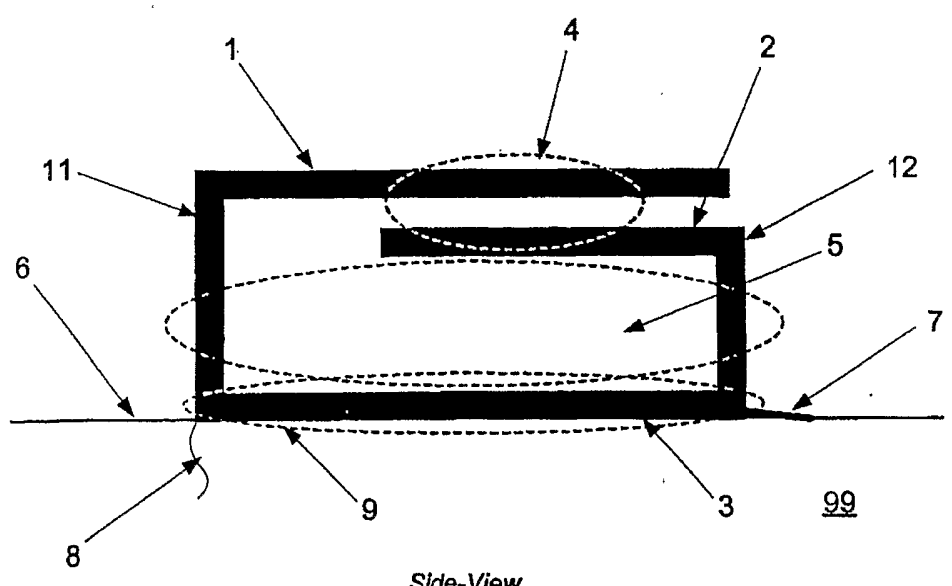
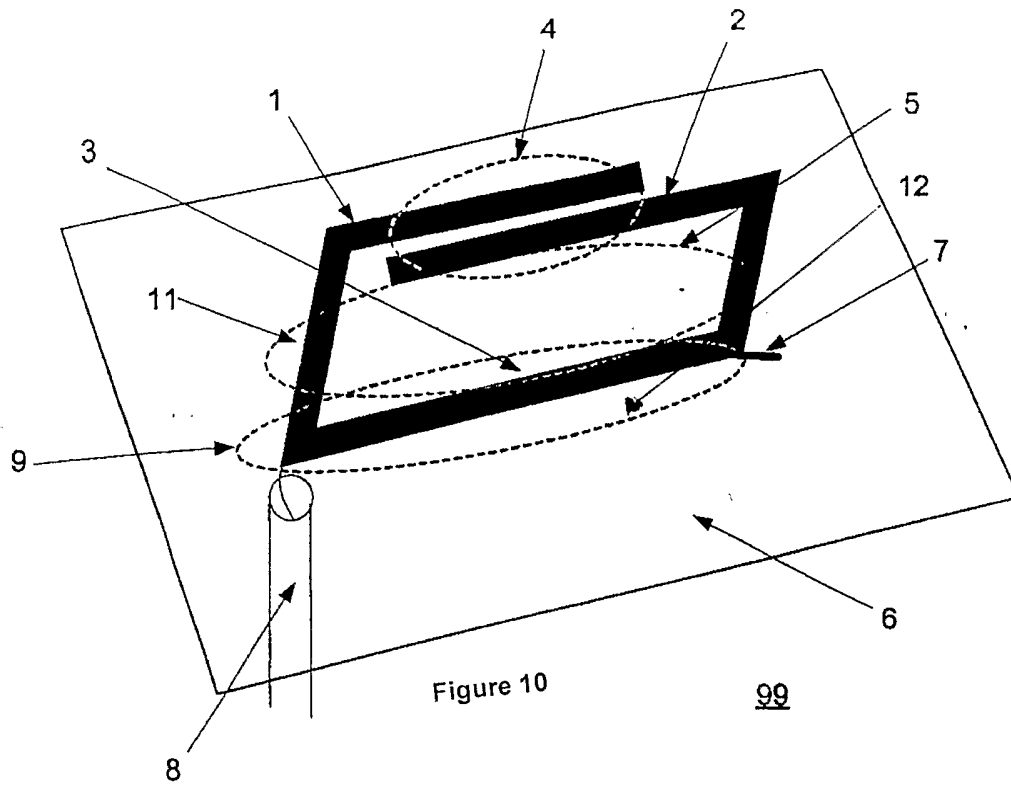
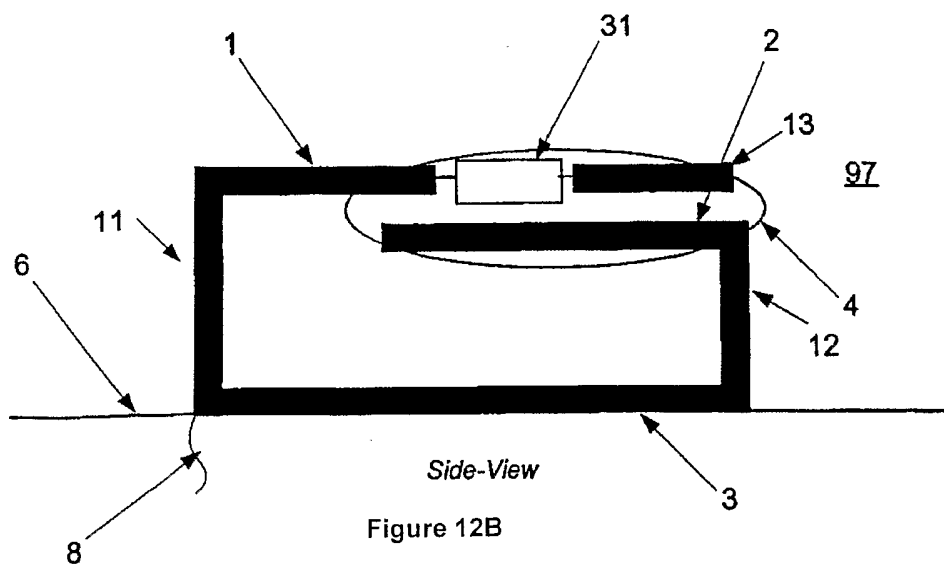
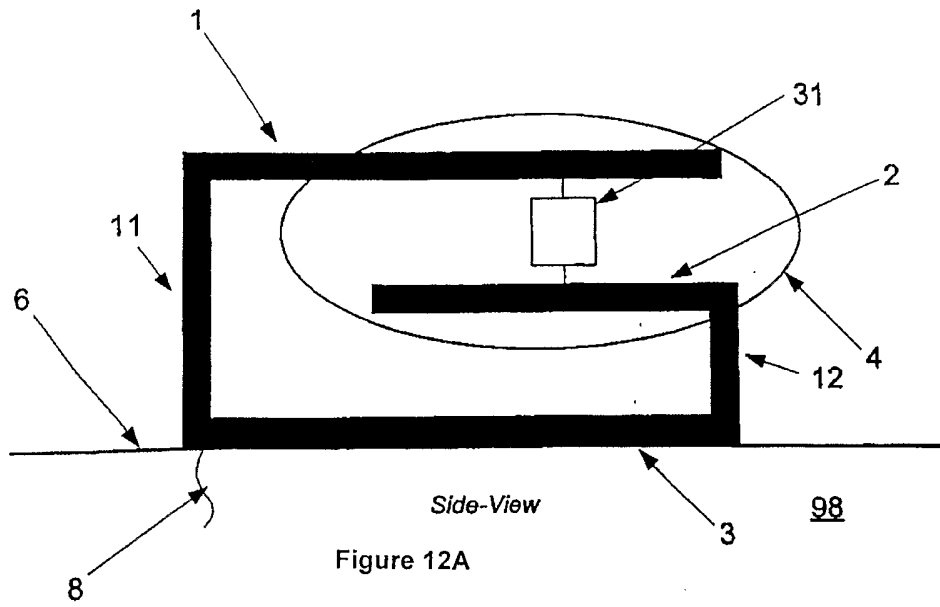
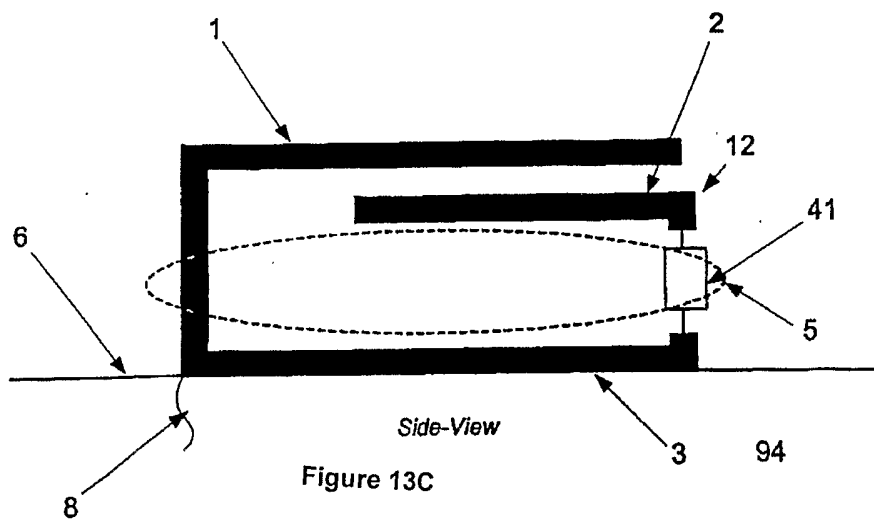
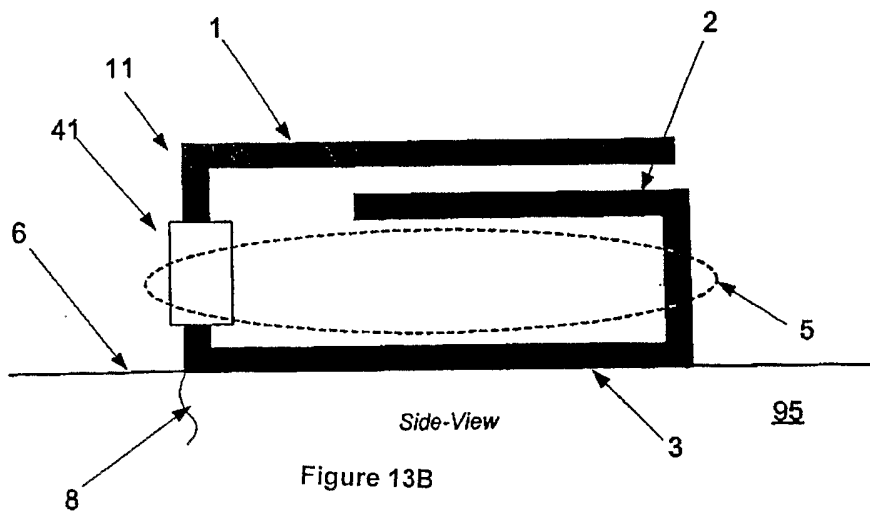
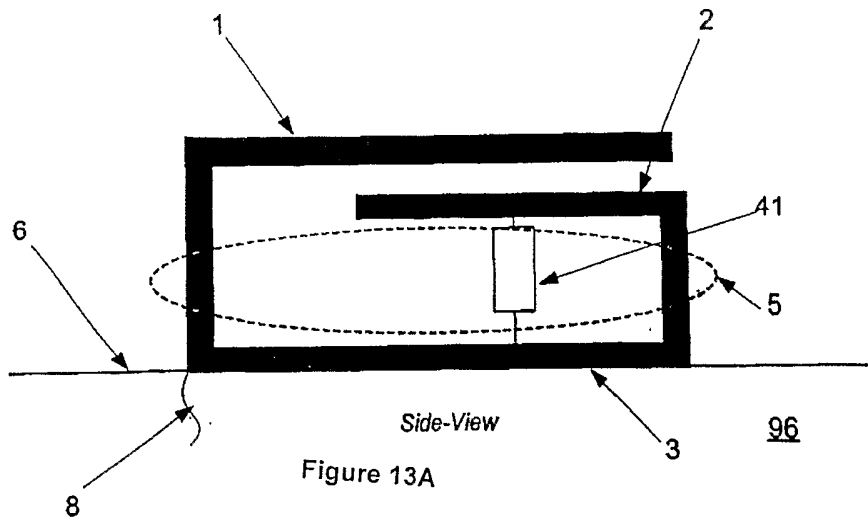

Figure 9







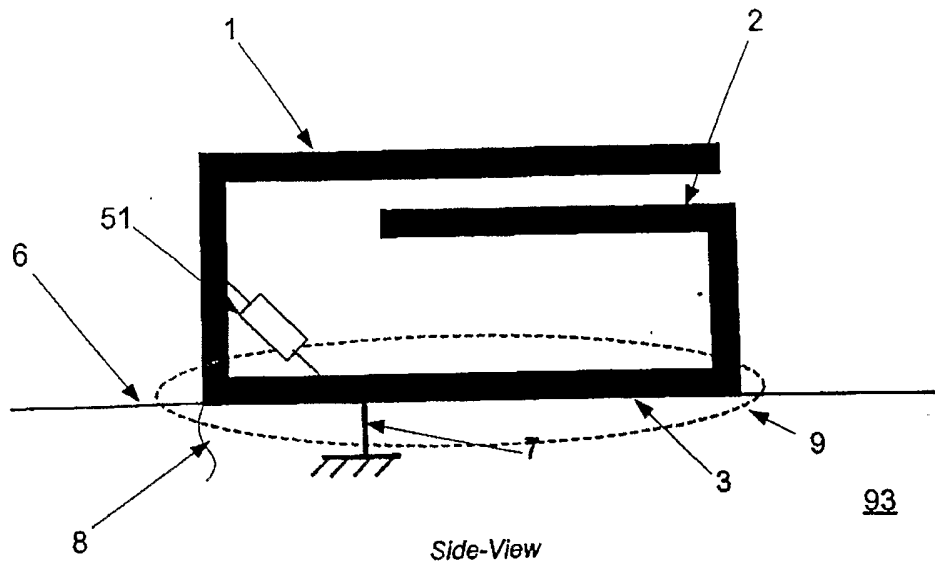

Figure 14A

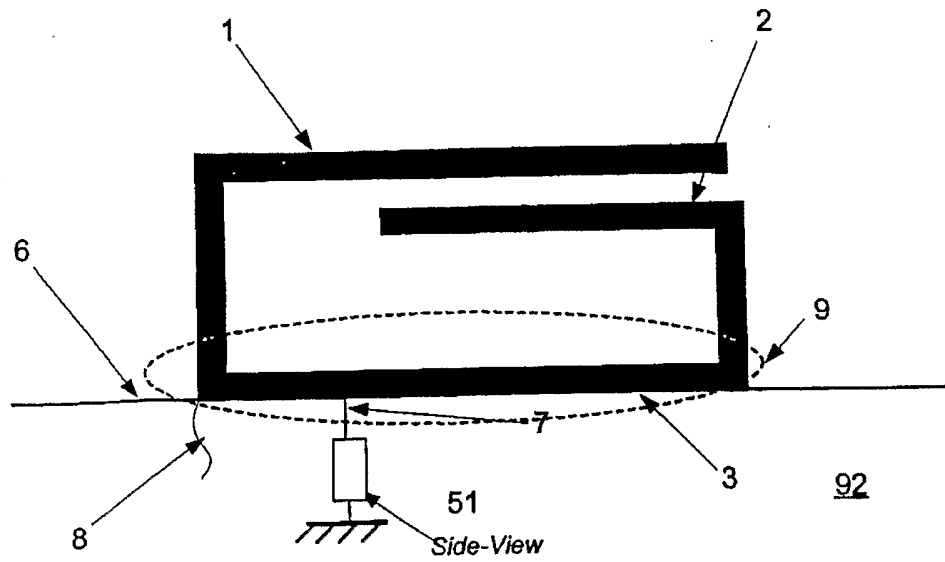

Figure 14B



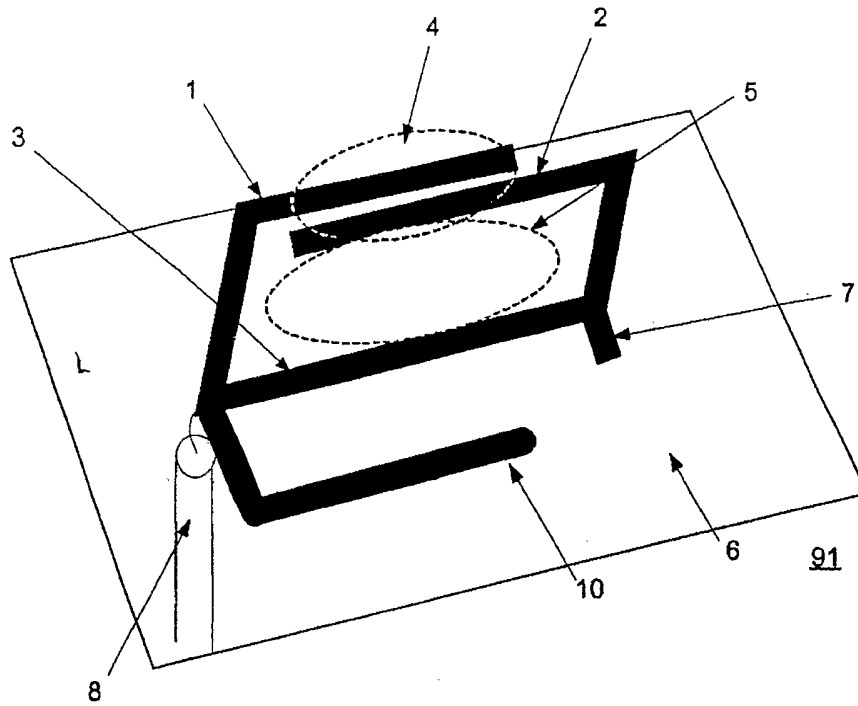

Figure 15A

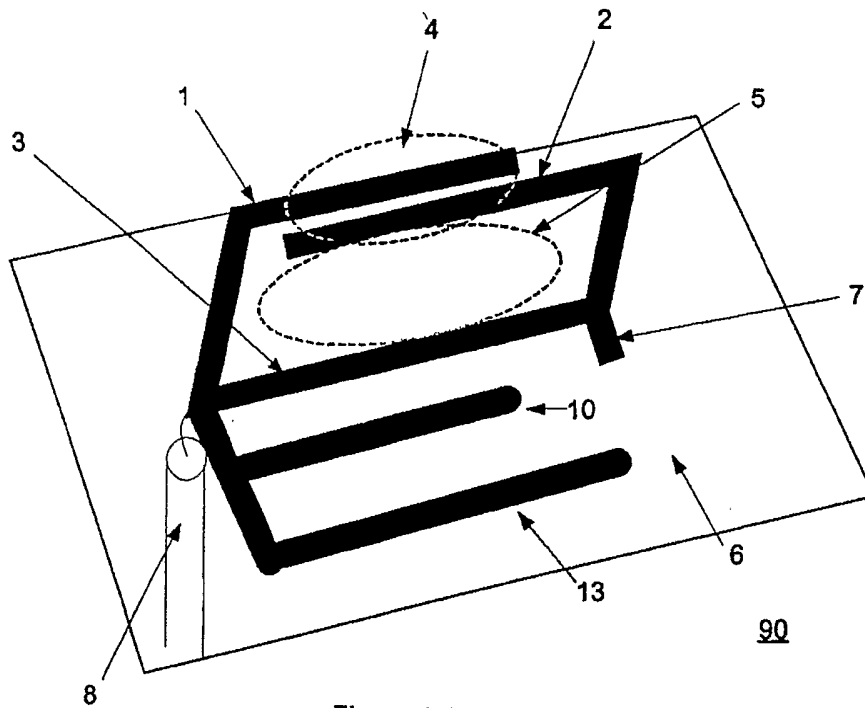

Figure 15B

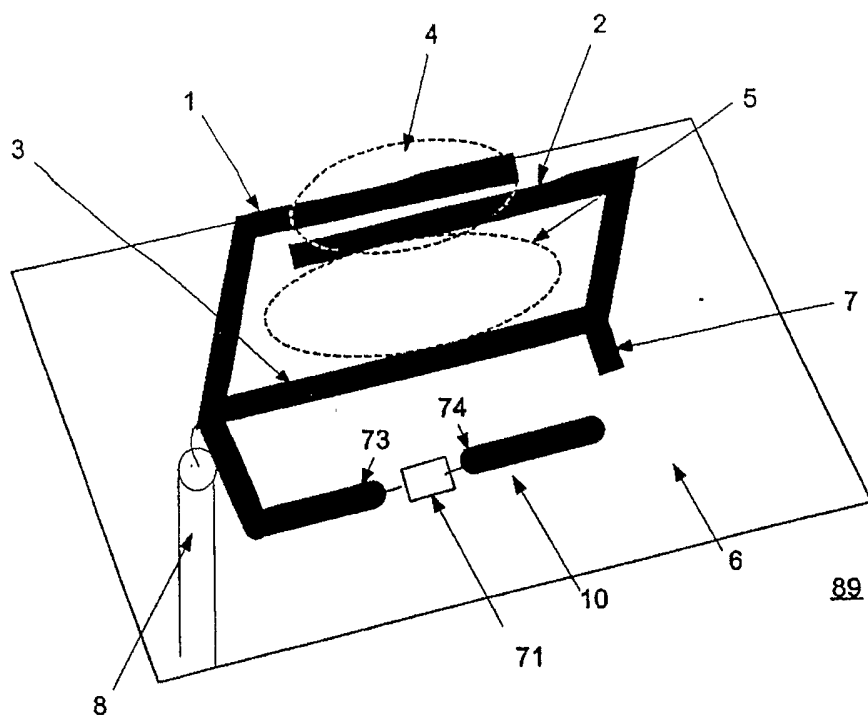

Figure 16A

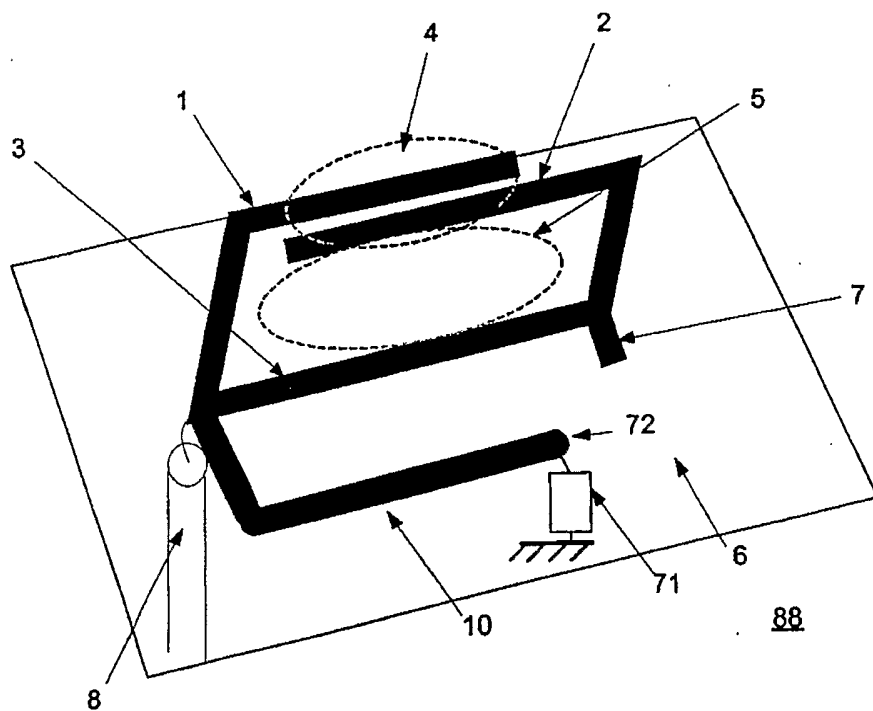

Figure 16B

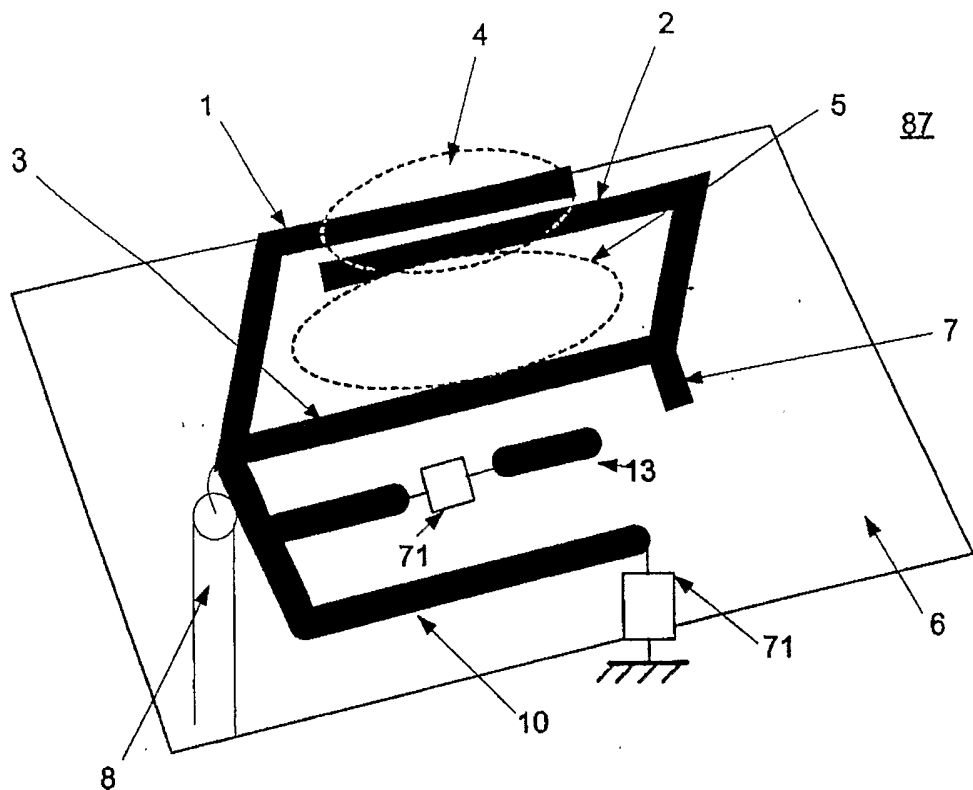

Figure 16C

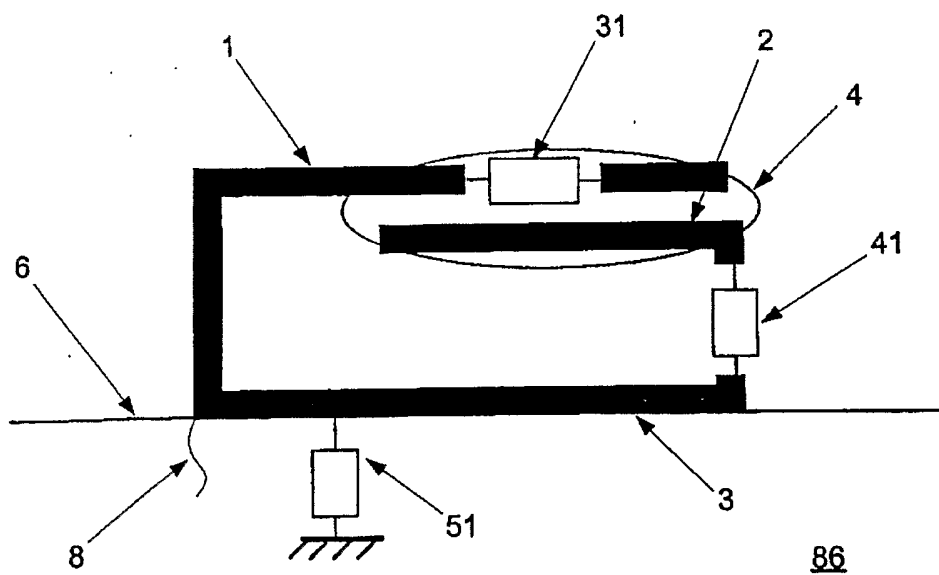
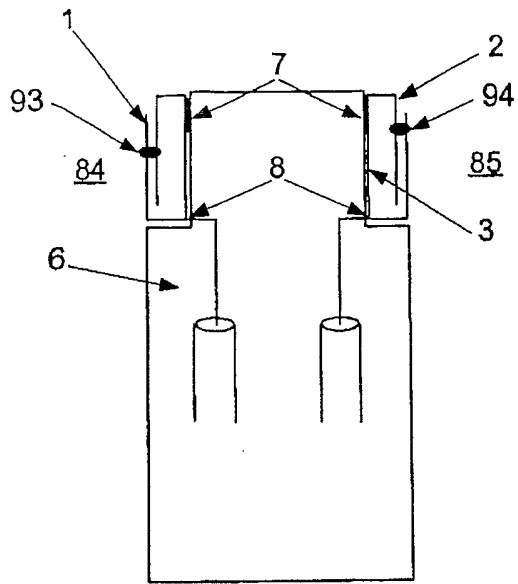
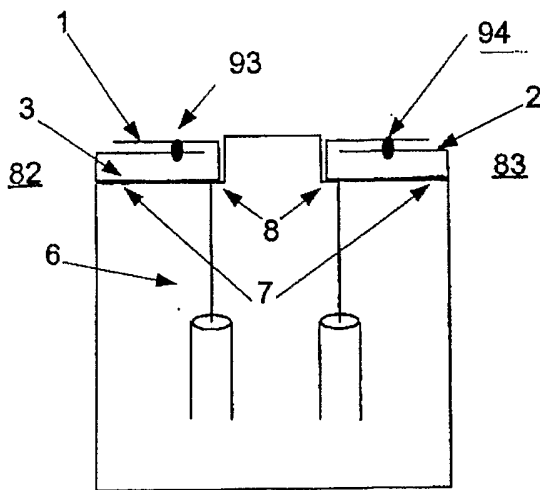

Figure 17



Top-View

Figure 18A



Top-View

Figure 18B

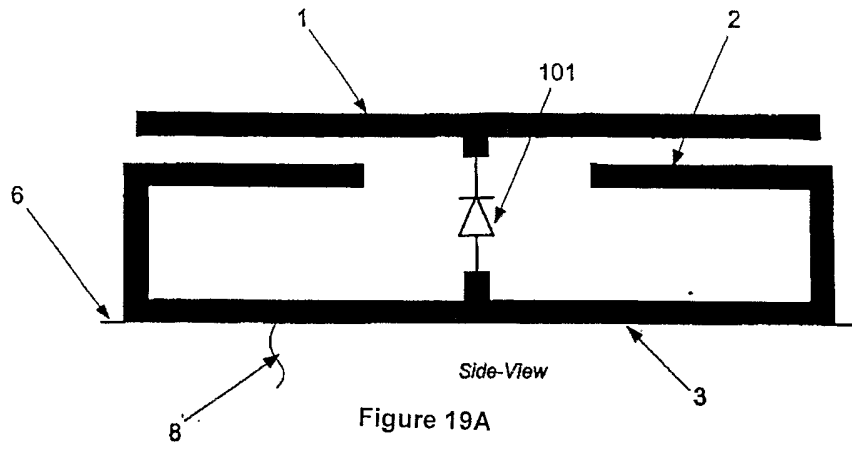

81

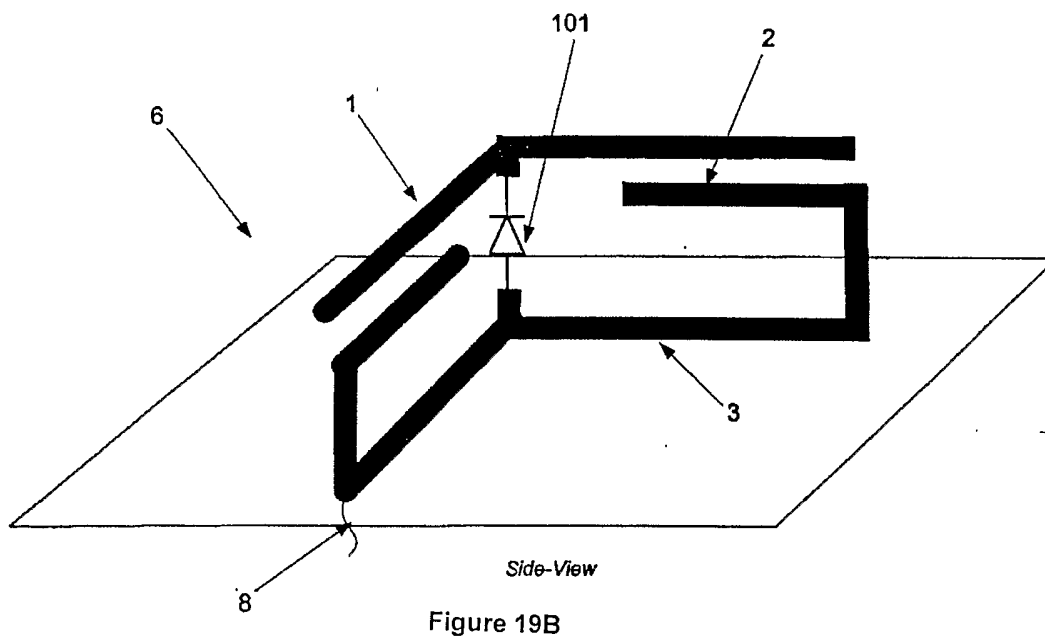

82

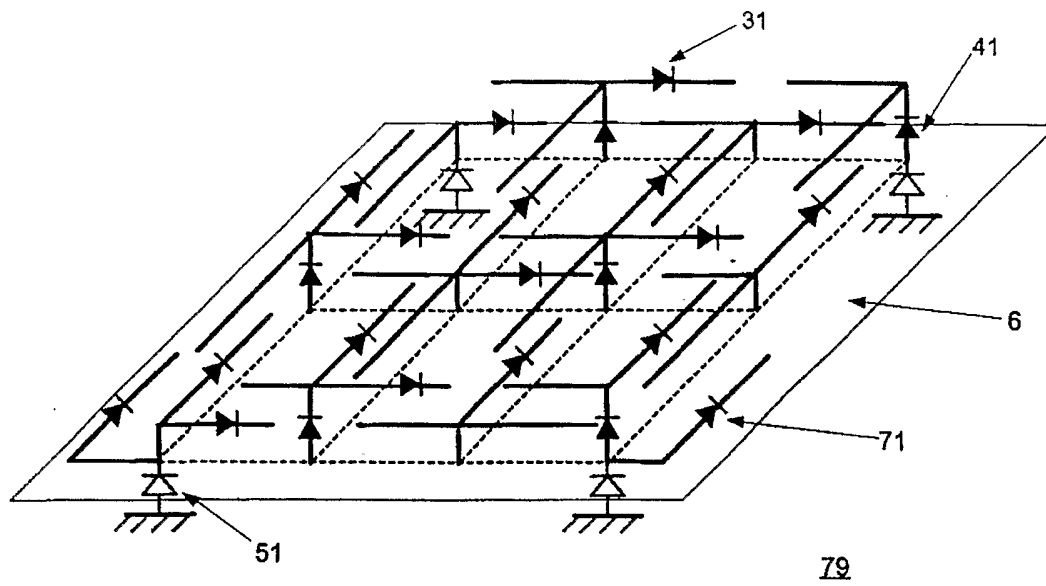
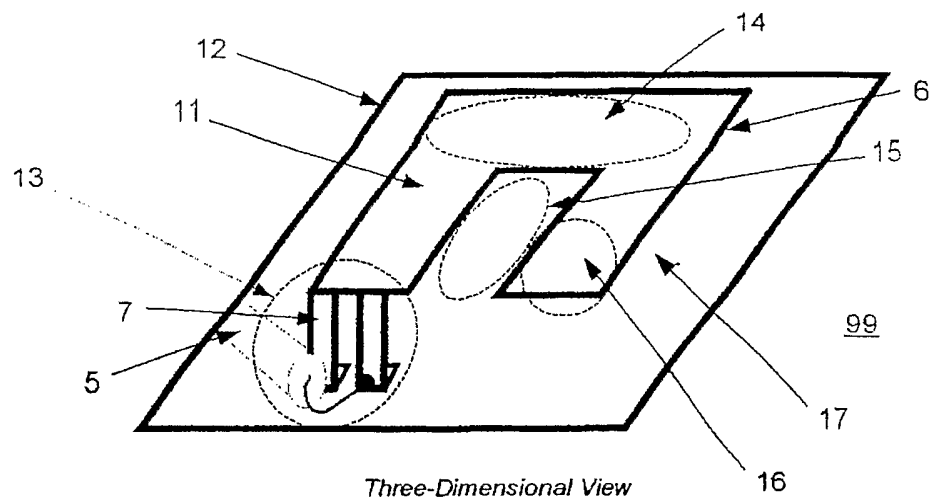
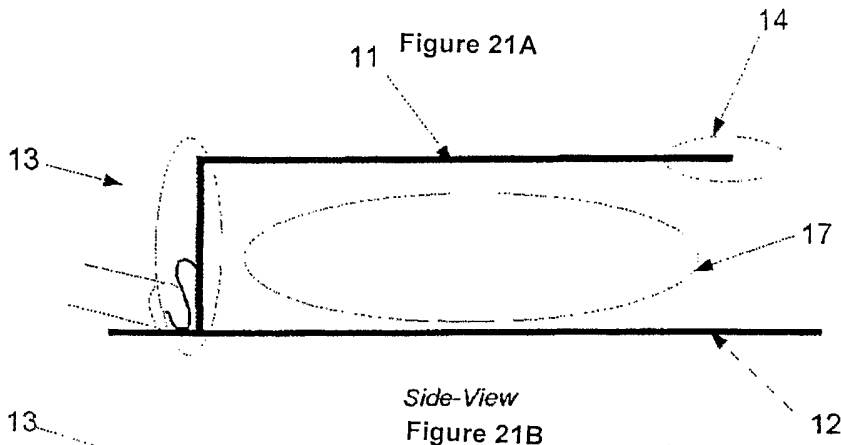

Figure 20



Three-Dimensional View

Figure 21A



Side-View

Figure 21B

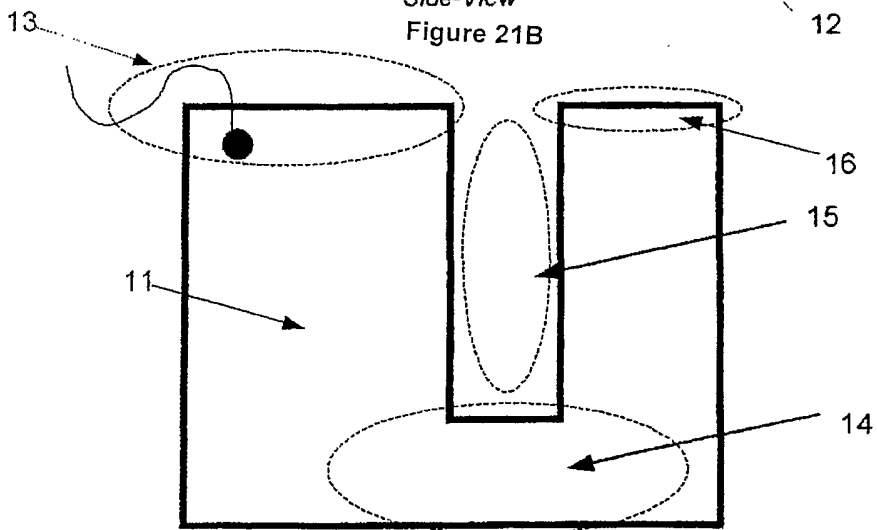

Bottom view of top portion

Figure 21C

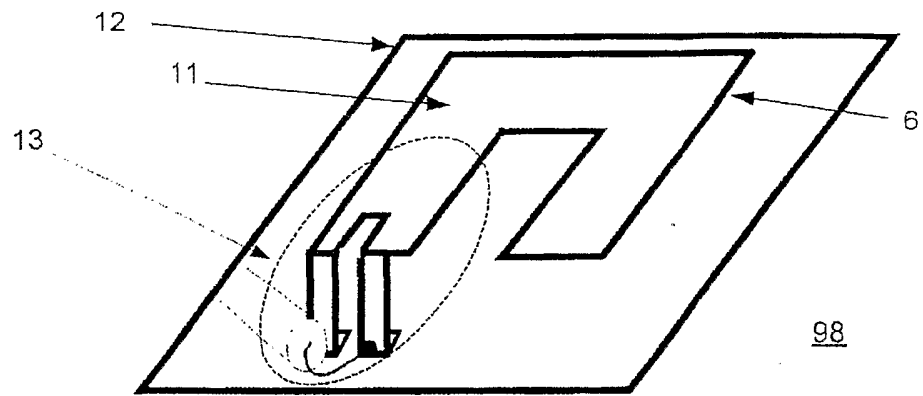

Three-Dimensional View

Figure 22A

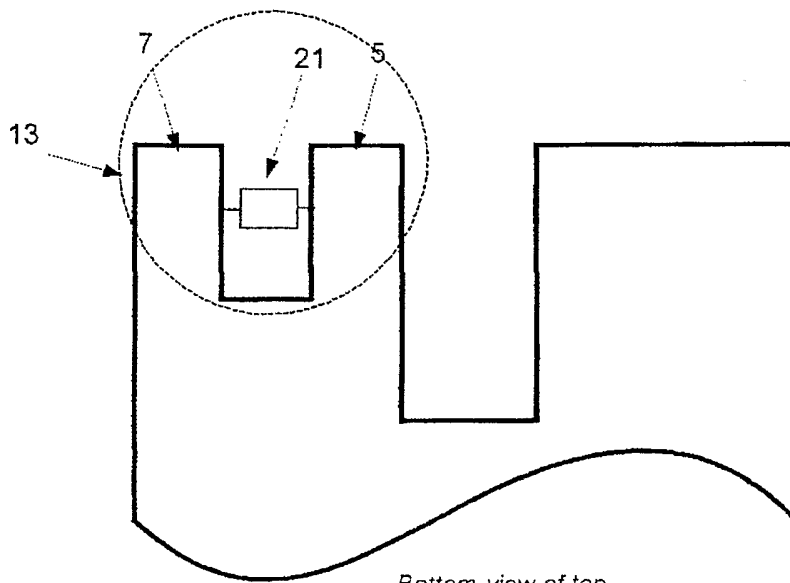

Bottom-view of top portion

Figure 22B



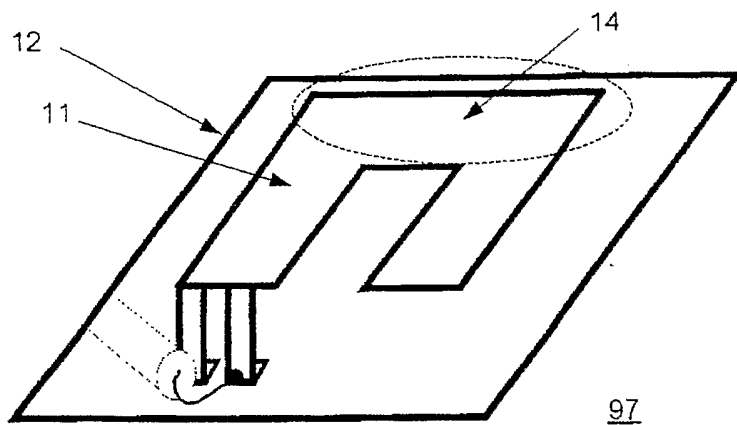

Three-Dimensional View

Figure 23A

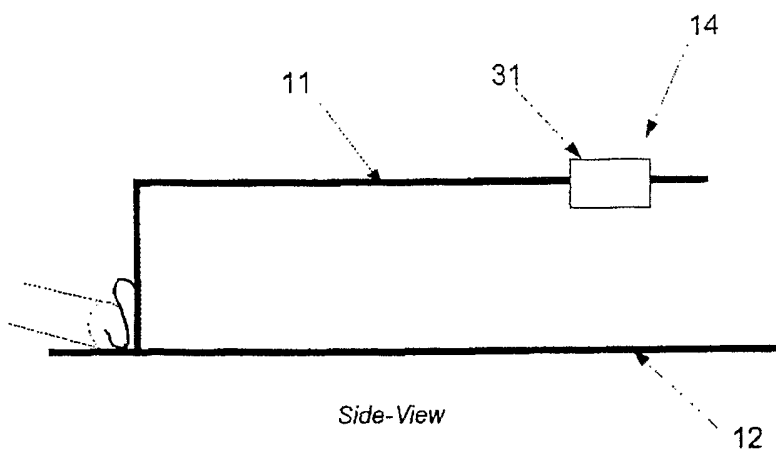

Side-View

Figure 23B

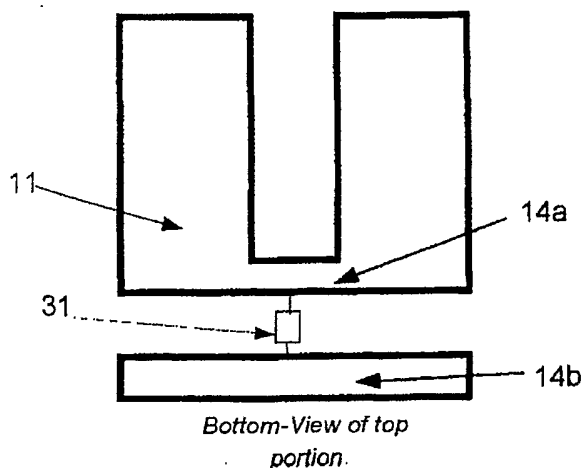

Bottom-View of top portion.

Figure 23C

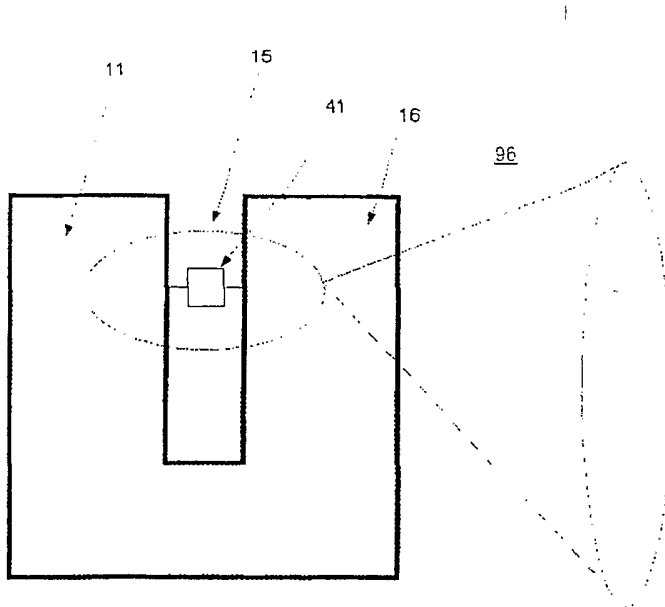

Figure 24A

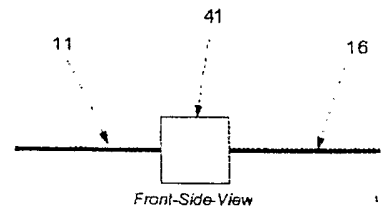

Figure 24B

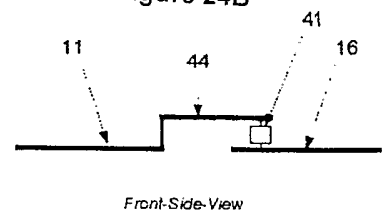

Figure 24C

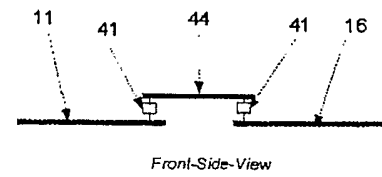
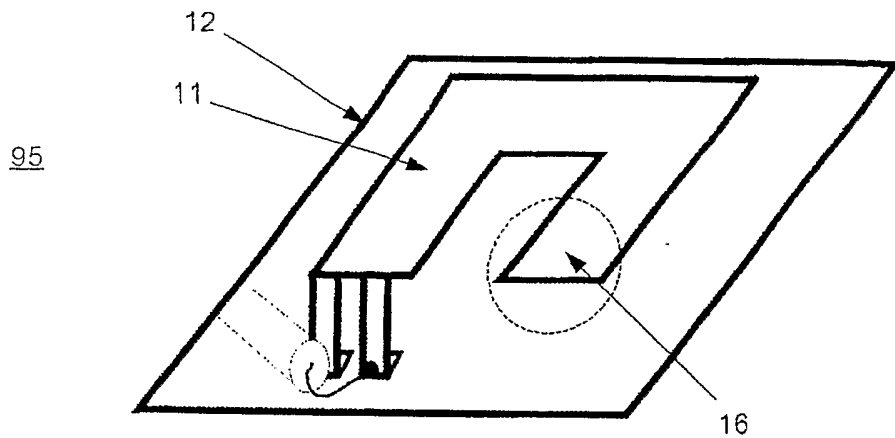
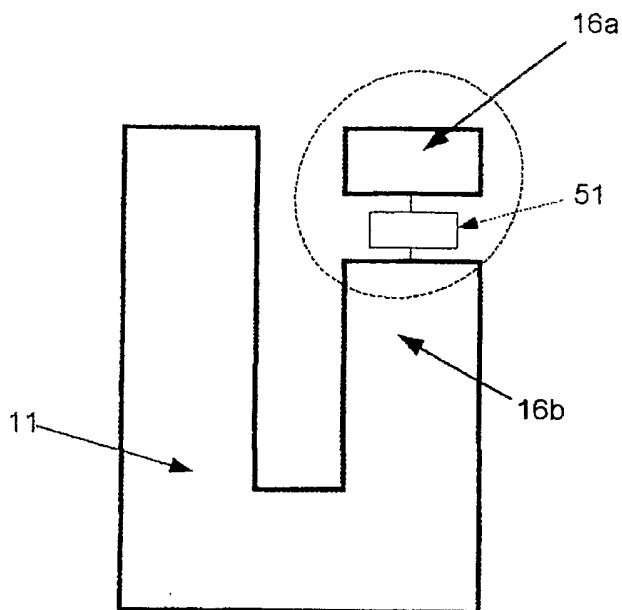

Figure 24D



Three-Dimensional View

Figure 25A



Bottom-View of top portion

Figure 25B

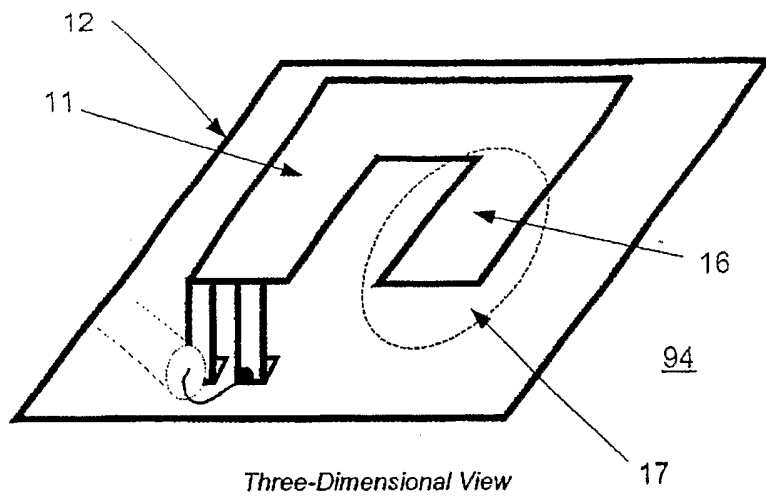

Three-Dimensional View  
Figure 26A

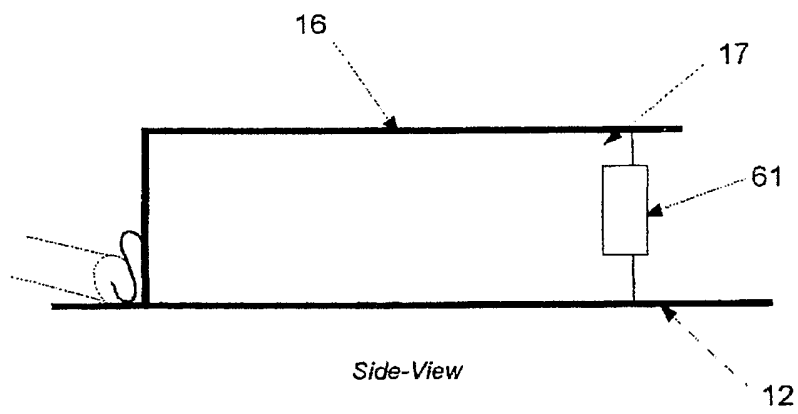

Side-View  
Figure 26B

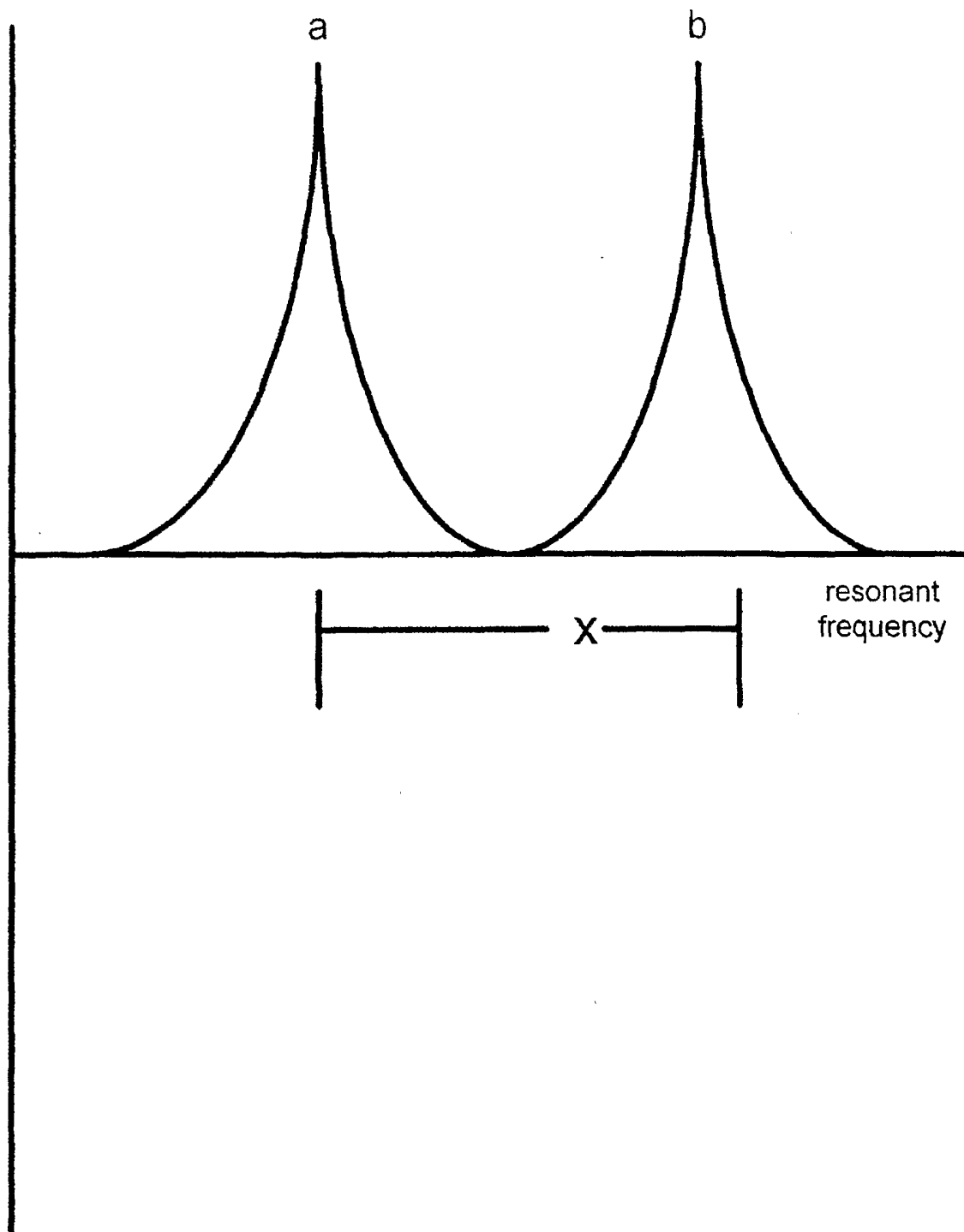

Figure 27A

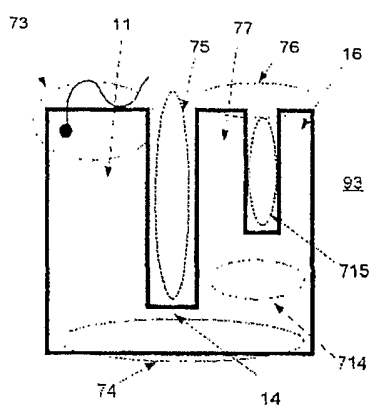

Figure 27B

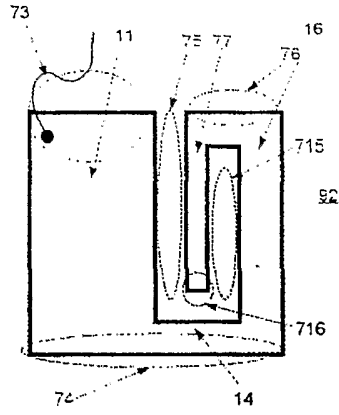

Figure 27C

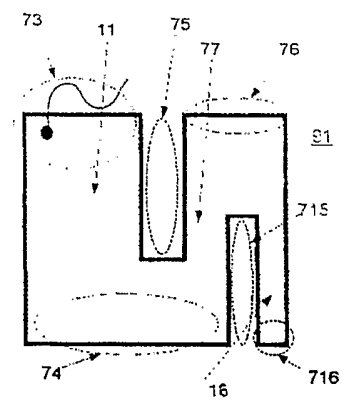
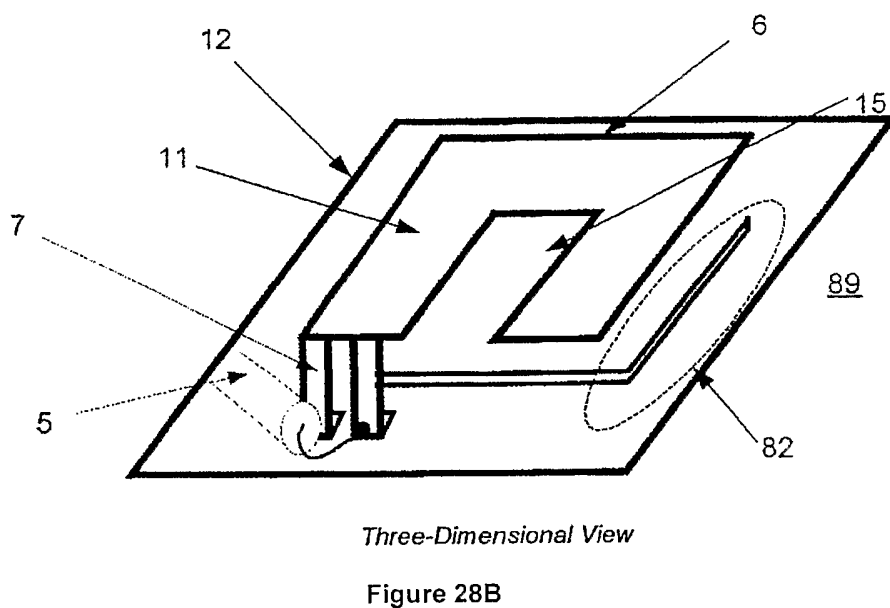
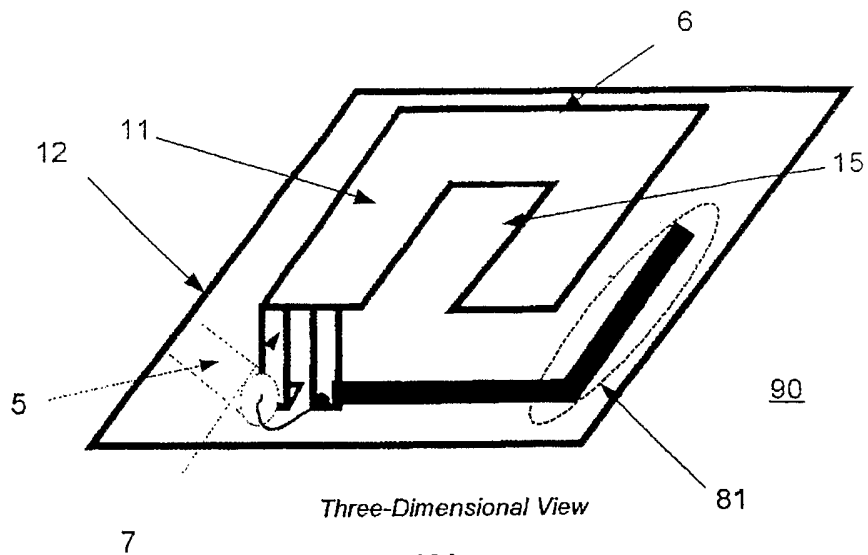

Figure 27D



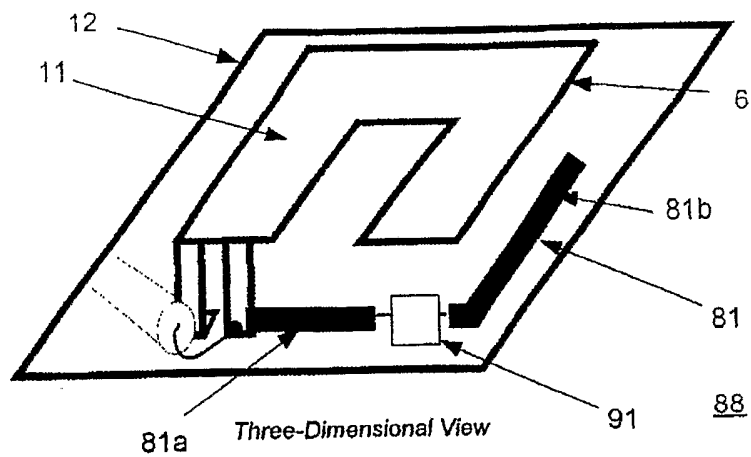

Figure 29A

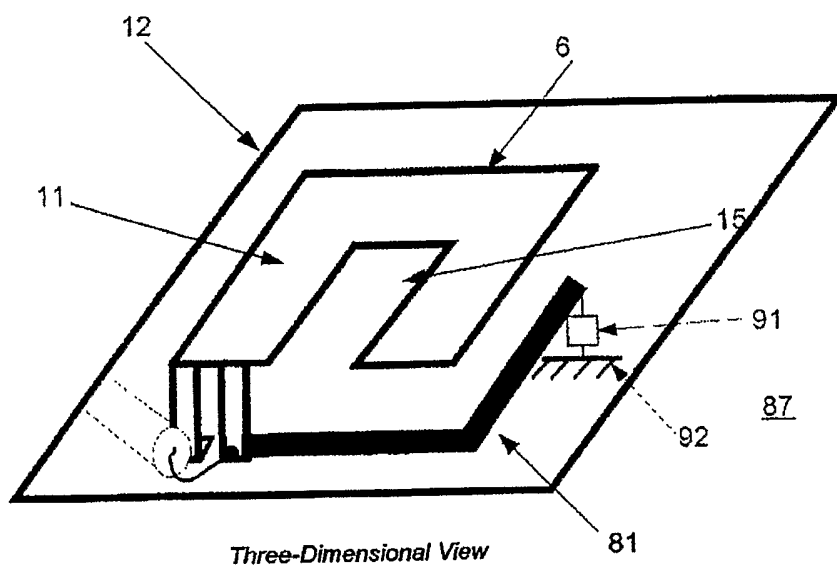

Figure 29B



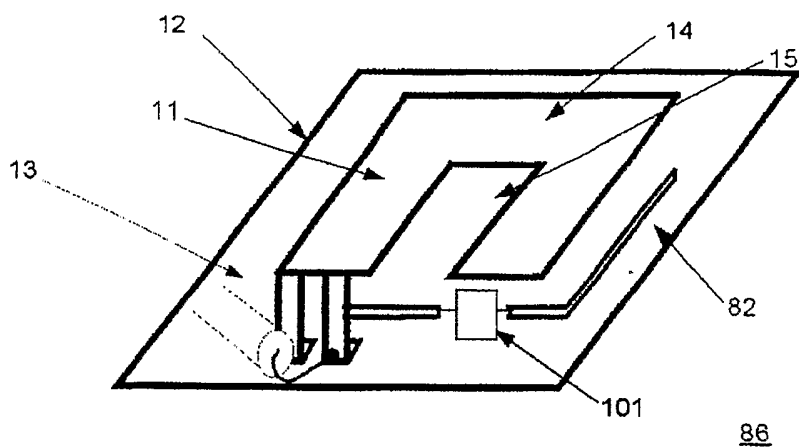

Figure 30A

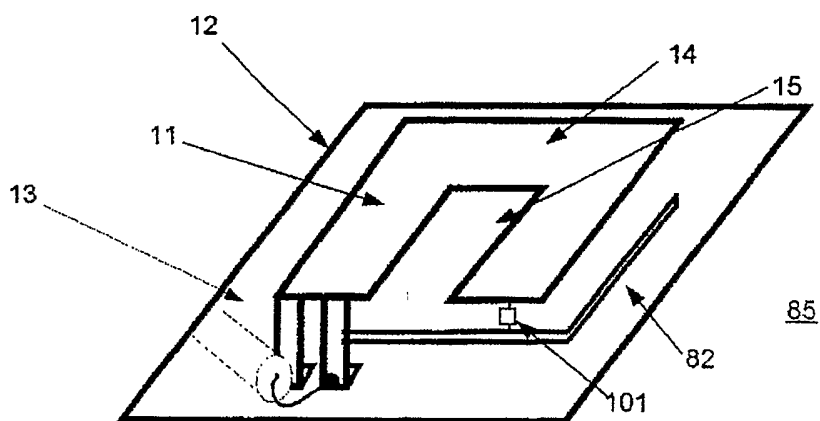

Figure 30B

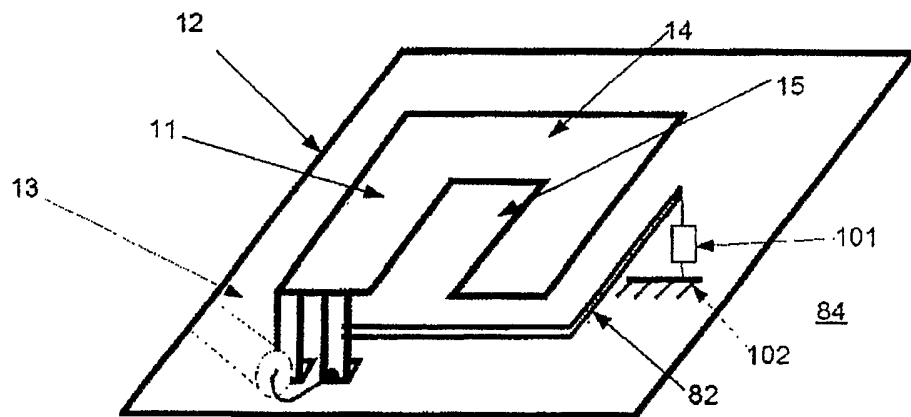
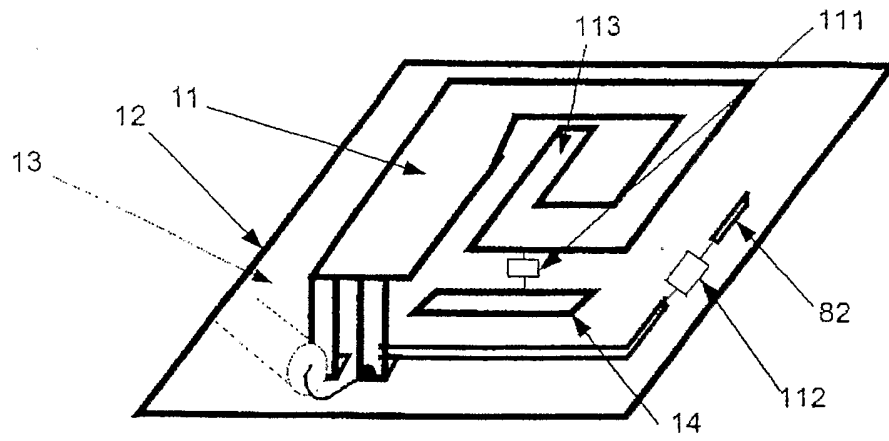

Figure 30C



Three-Dimensional View  
Figure 31A

83

**INTERNATIONAL SEARCH REPORT**

International application No.  
PCT/US03/37031

**A. CLASSIFICATION OF SUBJECT MATTER**

IPC(7) : H01Q 1/38, 1/24, 9/16  
 US CL : 343/700MS, 702, 793, 846, 848  
 According to International Patent Classification (IPC) or to both national classification and IPC

**B. FIELDS SEARCHED**

Minimum documentation searched (classification system followed by classification symbols)

U.S. : 343/700MS, 702, 793, 846, 848

Documentation searched other than minimum documentation to the extent that such documents are included in the fields searched  
 NONE

Electronic data base consulted during the international search (name of data base and, where practicable, search terms used)

EAST  
 search items: antenna, tongue, extension, slot, cutout, ground plane, active, control, stub, dipole

**C. DOCUMENTS CONSIDERED TO BE RELEVANT**

Category*	Citation of document, with indication, where appropriate, of the relevant passages	Relevant to claim No.
X	US 5,241,321 A (TSAO) 31 August 1993 (31.08.1993), Figure 2 & 7.	1, 2, 5-9
X,P --- Y,P	US 6,529,749 B1 (HAYES et al) 04 March 2003 (04.03.2003), see entire document.	16, 19, 28, 30, 32-34, 36-43, 47 ----- 20-27, 35, 51, 61-63, 74-76
X --- Y	US 3,827,053 A (WILLIE et al) 30 July 1974 (30.07.1974), Figures 5-6.	16, 17, 29, 46 ----- 35
X	US 5,936,590 A (FUNDER) 10 August 1999 (10.08.1999), Figure 4.	44

Further documents are listed in the continuation of Box C.  See patent family annex.

* Special categories of cited documents:	"T"	later document published after the international filing date or priority date and not in conflict with the application but cited to understand the principle or theory underlying the invention
"A" document defining the general state of the art which is not considered to be of particular relevance	"X"	document of particular relevance; the claimed invention cannot be considered novel or cannot be considered to involve an inventive step when the document is taken alone
"E" earlier document published on or after the international filing date	"Y"	document of particular relevance; the claimed invention cannot be considered to involve an inventive step when the document is combined with one or more other such documents, such combination being obvious to a person skilled in the art
"L" document which may throw doubts on priority claim(s) or which is cited to establish the publication date of another citation or other special reason (as specified)	"&"	document member of the same patent family
"O" document referring to an oral disclosure, use, exhibition or other means		
"P" document published prior to the international filing date but later than the priority date claimed		

Date of the actual completion of the international search 05 MARCH 2004	Date of mailing of the international search report <b>05 APR 2004</b>
----------------------------------------------------------------------------	--------------------------------------------------------------------------

Name and mailing address of the ISA/US Commissioner of Patents and Trademarks Box PCT Washington, D.C. 20231 Facsimile No. (703) 305-3230	Authorized officer SHIH-CHAO CHEN Telephone No. (571) 272-1819
-------------------------------------------------------------------------------------------------------------------------------------------------------	----------------------------------------------------------------------



INTERNATIONAL SEARCH REPORT

International application No.  
PCT/US03/37031

C (Continuation). DOCUMENTS CONSIDERED TO BE RELEVANT

Category*	Citation of document, with indication, where appropriate, of the relevant passages	Relevant to claim No.
Y	US 6,008,764 A (OLLIKAINEN et al) 28 December 1999 (28.12.1999), Figure 3.	20-27
Y	US 6,417,807 B1 (HSU et al) 09 July 2002 (09.07.2002), Figure 2.	51, 61-63, 74-76
X	US 5,087,922 A (TANG et al) 11 February 1992 (11.02.1992), Figure 3.	48, 78
X	US 6,362,789 B1 (TRUMBULL et al) 26 March 2002 (26.03.2002), Figure 1.	49-50, 52-60, 64-73, 77
—		_____
A		1-48, 78