

(No Model.)

D. J. HAUSS.
ARC LAMP.

No. 369,640.

Patented Sept. 6, 1887.

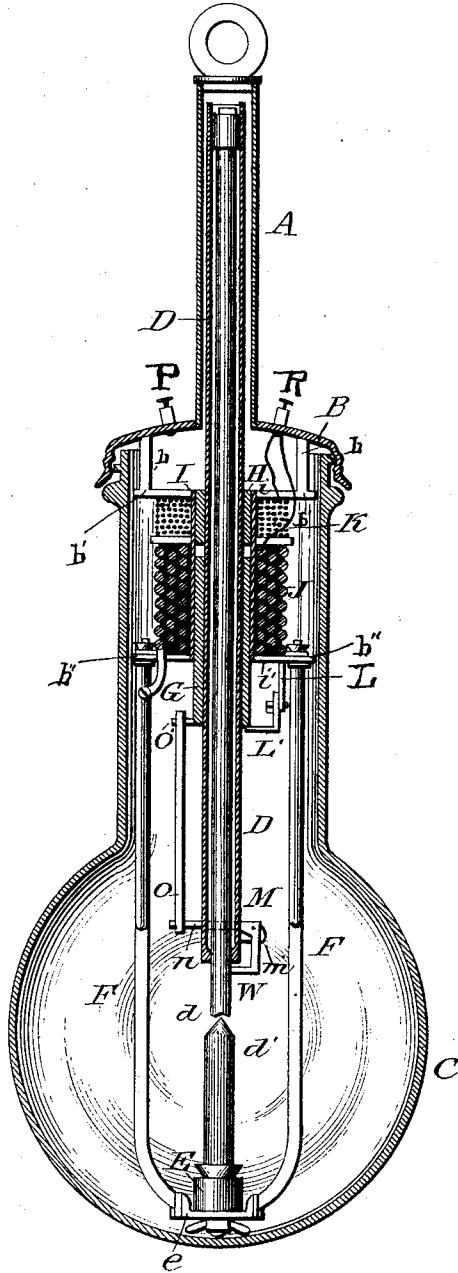

Witnesses:

Joseph Littell
J. H. Chas. Smith

Inventor:

David J. Hauss
by John E. Jones
his attorney

UNITED STATES PATENT OFFICE.

DAVID J. HAUSS, OF CINCINNATI, OHIO, ASSIGNOR TO THE HAUSS ELECTRIC MANUFACTURING CO., OF SAME PLACE.

ARC LAMP.

SPECIFICATION forming part of Letters Patent No. 369,640, dated September 6, 1887.

Application filed August 9, 1884. Serial No. 140,157. (No model.)

To all whom it may concern:

Be it known that I, DAVID J. HAUSS, a citizen of the United States, and a resident of Cincinnati, in the county of Hamilton and the State of Ohio, have invented certain new and useful Improvements in Electric-Arc Lamps, of which the following is a specification.

My invention relates to an arc lamp; and it consists in the provision, in connection with the upper-carbon holder, of an arc-regulating device composed of a sliding solenoid-core, a surrounding solenoid-helix, a stationary electro-magnet, and a shunt-coil, all suitably connected in circuit and adapted to operate as hereinafter fully described.

My invention further consists in the provision, in connection with the solenoid-core and the upper-carbon holder, of a carbon-feed clutch, which is composed of an angular bent lever pivoted to a lug at the lower end of said carbon-holder, and pivotally connected by a rod or bar with said solenoid-core.

The accompanying drawing is a sectional elevation of an electric-arc lamp embodying my invention.

A represents the suspension-tube; B, the cap-plate, and C the globe, in which the working parts of the lamp are all placed, so as to be wholly incased, and thereby fully protected from atmospheric and other deleterious effects.

D represents the upper-carbon holder passing vertically through the cap-plate B into the suspension-tube A.

d is the upper carbon, and *d'* the lower carbon.

E represents the lower-carbon holder mounted upon plate *e* at the lower ends of the suspension-rods F. These rods F form a part of the general frame of the lamp, and are preferably made of very thin flat metal, so that their obstruction to the rays of light from the carbons shall be reduced to a minimum. Plate *e* unites the rods F at their lower ends, and serves as a seat for the lower-carbon holder, as aforesaid.

G represents a solenoid-core made, as customary, of soft iron and encompassing the carbon-holder B. H represents a soft-iron core, also encompassing said carbon-holder, and lo-

cated a short distance above said solenoid-core, thereby leaving an intervening space between it and the solenoid-core. Both cores G and H are encircled by a metallic spool, I, upon the outer circumference of which is wound a low-resistance or "principal" helix, J, of coarse wire, and a high-resistance or shunt helix, K, of fine wire, the helix J being wound at the lower part of the spool and forming the solenoid-coil, and the helix K being wound at the upper part of the spool at the point where the core H is permanently fixed, and forming the differential or shunt coil. The presence of the differential coil K, when charged with the current, causes the core H to become energized, thereby forming of said core an electro-magnet with the powers of attraction and repulsion.

i represents the upper flange or plate of spool I, and *i'* the lower one.

On the bottom of the cap-plate B are lugs *b b b*, which fit upon perforated lugs *b'*, projecting from the upper flange, *i*, of spool I. Screws are passed through the holes in said lugs *b'* into screw-threaded holes in lugs *b*, to secure the cap-plate B and said spool-flange together. The lower flange, *i'*, of the spool is also provided with perforated lugs *b''*, through the holes of which the screw-threaded tops of the suspension-rods F pass, and are secured in place by thumb screws. The said tops of the suspension-rods F are suitably insulated from electric connection with the flange *i'*.

L represents a slotted depending arm on spool-flange *i'*, and L' is an arm projecting laterally from arm L into the downward path of the solenoid-core G, to serve as a stop therefor. Arm L' is adjustably mounted in the slotted arm L, as shown, to regulate the falling point of said solenoid-core and to adjust the equilibrium of all the lamps in circuit.

M represents an angular lever pivotally attached to a lug, *m*, at the lower end of the carbon-holder D.

m' is a depending arm at one end of lever M, to which arm a forked arm, N, is attached, which projects laterally toward the upper carbon, with its forked end spanning said carbon to clutch and hold it when necessary.

n represents the split or forked end of lever M, which is the end opposite to the pendent arm *m*'.

O is a vertical link bar or rod pivotally mounted at its lower end in the forked end *n* of lever M, and pivotally connected at its upper end with a lug or pin, O', projecting from the lower end of solenoid-core G.

The operation of my lamp is as follows: The current flows from any source of supply through a suitable conductor to the positive binding-post P; thence through the cap-plate B; thence through lugs *b b* to the flange *i* of spool I; thence to the upper-carbon holder D; thence downward through the upper and lower carbons; thence upward through the suspension-rods F; thence through the low-resistance or solenoid coil J, the lower end of whose wire is attached to the upper end of one of said rods F. A portion of the current passing through helix J passes by means of a shunt-wire connecting the helix J and high-resistance coil K into and through said helix K, and thence by the insulated wire Q to the negative binding-post R. The current which passes through the low-resistance or solenoid coil J acts upon the soft-iron solenoid-core G only, and serves to centralize it in the usual manner, or, in other words, serves to bring the opposite ends of said core equidistant from the center of said coil J. This action of core G—which core, as before stated, encompasses the upper-carbon holder D—causes said holder with its carbon to rise, and thereby form the arc between the two carbons. The upward movement of the solenoid-core G is greatly accelerated and rendered very sensitive by the attractive force set up between it and the core H. Core H being a stationary one and the core G a reciprocating one, the magnetism in core G and its close proximity to core H causes core G to give way and be attracted by said core H, as customary in the action of all electro-magnets. The solenoid-core G slides freely upon the carbon-holder D, so that the link bar or rod O at the lower end of the core and connecting with the pivotal clutch M N can be brought into engagement with the upper carbon to regulate its height above the lower carbon and temporarily hold it so till it breaks off or becomes consumed. When the arc becomes too wide between the two carbons and the resistance at that point too great, the current then increases in the shunt-coil K, thereby charging the lower end of said stationary soft-iron core H, which is now an electro-magnet, with the same polarity as the upper end of solenoid-core G, the effect being to repel the said solenoid-core, causing the carbon-holder D to descend and the carbon to feed.

I claim—

1. In an electric-arc lamp, the combination of a hollow spool having a helix of high resistance wound around its upper portion and a helix of low resistance wound around its lower portion, a hollow core fixed permanently and rigidly within the upper portion

of the spool opposite the helix of high resistance, a hollow solenoid within the lower portion of the spool, the upper end of which is below and at a slight distance from the lower end of the fixed core, a movable feed-tube within the core and solenoid, a carbon within said tube, a frame suspended from the spool, a carbon secured to the frame, and means, substantially as described, for regulating the movement of the upper carbon and for passing a current of electricity through the same.

2. In an electric-arc lamp, the combination of a spool having a helix of high resistance wound around its upper portion and a helix of low resistance wound around its lower portion, a hollow core rigidly secured within the core opposite the helix of high resistance, a hollow solenoid within the lower end of the spool, the upper end of which is below and at a slight distance from the lower end of the core, a movable feed-tube within the core and solenoid and extending above and below the same, a carbon within the tube, a slotted arm depending from the lower end of the spool, an arm adjustably secured to the slotted arm, one end of which projects laterally into the down path of the solenoid, a frame depending from the spool, a carbon secured to said frame, and means, substantially as described, for regulating the movement of the upper carbon and for passing a current of electricity through the same.

3. In an electric-arc lamp, the combination of a hollow spool, a helix of high resistance and a helix of low resistance wound around the same, a hollow solenoid within the spool, the lower end of which is provided with a lug, a feed-tube within the solenoid, the lower end of which is also provided with a lug, an angular lever or finger-like clutch pivotally secured to the lug upon the feed-tube, one arm of which is forked and spans the lower end of the tube, a vertical link or bar pivotally secured at one end to the forked end of the lever and at the other end to the lug upon the lower end of the solenoid, a frame suspended from the lower end of the spool, a carbon in the feed-tube and also in the frame, and means, substantially as described, for passing a current of electricity through the carbons and for regulating the downward movement of the solenoid.

4. In an electric-arc lamp, the combination of a spool having means, substantially as described, for supporting the upper carbon and passing a current of electricity through it, two rods secured to and insulated from the lower end of the spool, the lower ends of which are flat or knife-shaped and the upper ends are screw-threaded, nuts upon the upper ends of the rods, a plate secured to the lower ends of the rods, and a carbon secured to the plate.

5. In an electric-arc lamp, the combination of a cap having a screw-threaded flange around it, a tube secured to the central portion of the cap, a screw-cover for closing the

70

75

80

85

90

95

100

105

110

115

120

125

130

upper end of the tube, a globe the upper portion of which is screw-threaded and provided with a lug or projection, rods secured to the under side of the cap, a spool secured to the lower end of the rods, having helices wound around it, a feed-tube within the tube secured to the cap and projecting down through the spool into the globe, a carbon within the feed-tube, a frame suspended from the spool, a carbon secured to the frame, and means, sub-

stantially as described, for regulating the movement of the carbons and for passing a current of electricity through them.

In testimony that I claim the foregoing I have hereunto set my hand, this 2d day of 15 August, 1884, in the presence of witnesses.

DAVID J. HAUSS.

Witnesses:

AARON E. MOORE,
W. M. LEMON.