



(72) JANOVEC, Jeffrey D., US

(71) MINNESOTA MINING AND MANUFACTURING COMPANY, US

(51) Int.Cl.<sup>6</sup> G02B 5/124

(30) 1996/04/10 (08/631856) US

(54) **FEUILLE A COINS DE CUBES, SOUPLE ET EN COUSSIN, ET  
SES PROCEDES DE FABRICATION**

(54) **PILLOWED FLEXIBLE CUBE-CORNER SHEETING AND  
METHODS OF MANUFACTURE**

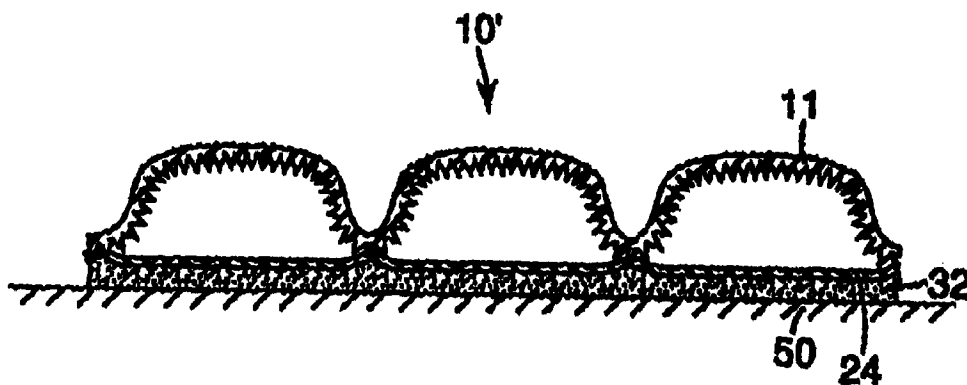

(57) L'invention concerne un article rétro réfléchissant à coins de cubes, durable et souple, s'adaptant à la dilatation et à la contraction du substrat polymère sous-jacent, ledit article étant pourvu d'un élément microstructuré courbé ou en coussin, relié selon un motif régulier à un élément d'étanchéité. L'article rétro réfléchissant a un état normal et un état sollicité. A l'état normal, l'élément microstructuré est sensiblement parallèle à l'élément d'étanchéité. A l'état sollicité, l'élément microstructuré est soit comprimé soit étiré, et l'élément d'étanchéité est sensiblement plat. L'article rétro réfléchissant peut être fixé sur des dispositifs de signalisation routière, tels que des tonneaux, des cônes ou des tubes en polymère conçus pour orienter et guider des automobilistes dans des zones de construction routière.

(57) A flexible, durable, cube-cornered retroreflective article capable of accommodating the expansion and contraction of the underlying polymeric substrate where such article has a pillowed or curved microstructured member bonded in a regular pattern to a sealing member. The retroreflective article has normal and stressed states. In the normal state, the microstructured member is substantially parallel with the sealing member. In the stressed state, the microstructured member is either compressed or elongated and the sealing member is substantially flat. The retroreflective article may be attached to traffic control devices, such as polymeric barrels, cones, or tubes to direct and guide motorists through road construction areas.



PCT

WORLD INTELLECTUAL PROPERTY ORGANIZATION  
International Bureau

## INTERNATIONAL APPLICATION PUBLISHED UNDER THE PATENT COOPERATION TREATY (PCT)

<b>(51) International Patent Classification<sup>6</sup> :</b> <b>G02B 5/124</b>	<b>A1</b>	<b>(11) International Publication Number:</b> <b>WO 97/38335</b>  <b>(43) International Publication Date:</b> 16 October 1997 (16.10.97)
<b>(21) International Application Number:</b> PCT/US97/04041 <b>(22) International Filing Date:</b> 12 March 1997 (12.03.97)  <b>(30) Priority Data:</b> 08/631,856                      10 April 1996 (10.04.96)                      US  <b>(71) Applicant:</b> MINNESOTA MINING AND MANUFACTURING COMPANY [US/US]; 3M Center, P.O. Box 33427, Saint Paul, MN 55133-3427 (US).  <b>(72) Inventor:</b> JANOVEC, Jeffrey, D.; P.O. Box 33427, Saint Paul, MN 55133-3427 (US).  <b>(74) Agents:</b> OLSON, Peter, L. et al.; Minnesota Mining and Manufacturing Company, Office of Intellectual Property Counsel, P.O. Box 33427, Saint Paul, MN 55133-3427 (US).		<b>(81) Designated States:</b> AL, AM, AT, AU, AZ, BA, BB, BG, BR, BY, CA, CH, CN, CU, CZ, DE, DK, EE, ES, FI, GB, GE, GH, HU, IL, IS, JP, KE, KG, KP, KR, KZ, LC, LK, LR, LS, LT, LU, LV, MD, MG, MK, MN, MW, MX, NO, NZ, PL, PT, RO, RU, SD, SE, SG, SI, SK, TJ, TM, TR, TT, UA, UG, UZ, VN, YU, ARIPO patent (GH, KE, LS, MW, SD, SZ, UG), Eurasian patent (AM, AZ, BY, KG, KZ, MD, RU, TJ, TM), European patent (AT, BE, CH, DE, DK, ES, FI, FR, GB, GR, IE, IT, LU, MC, NL, PT, SE), OAPI patent (BF, BJ, CF, CG, CI, CM, GA, GN, ML, MR, NE, SN, TD, TG).  <b>Published</b> <i>With international search report.</i>

**(54) Title:** PILLOWED FLEXIBLE CUBE-CORNER SHEETING AND METHODS OF MANUFACTURE**(57) Abstract**

A flexible, durable, cube-cornered retroreflective article capable of accommodating the expansion and contraction of the underlying polymeric substrate where such article has a pillowed or curved microstructured member bonded in a regular pattern to a sealing member. The retroreflective article has normal and stressed states. In the normal state, the microstructured member is substantially parallel with the sealing member. In the stressed state, the microstructured member is either compressed or elongated and the sealing member is substantially flat. The retroreflective article may be attached to traffic control devices, such as polymeric barrels, cones, or tubes to direct and guide motorists through road construction areas.

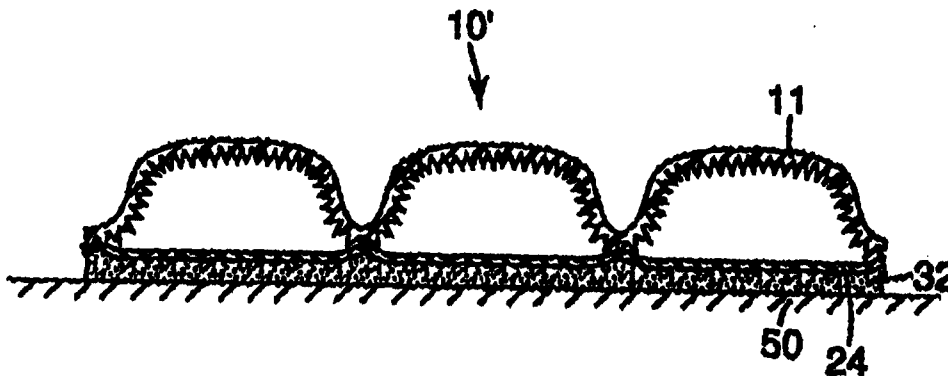

## **Pillowed Flexible Cube-corner Sheeting and Methods of Manufacture**

### Technical Field

This invention relates to a retroreflective sheeting, and more particularly  
5 a pillowed flexible cube-corner sheeting that accommodates the expansion and  
contraction of traffic control devices such as polymeric barrels, cones, or tubes.

### Background

A retroreflective sheeting has the ability to redirect incident light towards  
10 its originating source. This ability has led to the widespread use of retroreflective  
sheetings on a variety of articles. Very often retroreflective sheetings are used on flat  
inflexible articles, such as road signs and barricades. However, situations frequently  
arise which require the sheetings to be used on irregular or flexible surfaces. For  
example, a retroreflective sheeting may be adhered to irregular surfaces of traffic control  
15 devices, such as polymeric barrels, cones, or tubes. These devices are used typically  
near roadway construction areas to direct and guide motorists. Also, a retroreflective  
sheeting may be adhered to a flexible substrate such as a road worker's safety vest. In  
situations where the underlying substrate is irregular or flexible, the retroreflective  
sheeting desirably possesses good conformability and flexibility without sacrificing  
20 retroreflective performance.

There may also be situations where the underlying substrate expands and  
contracts at a different rate than the retroreflective sheeting. For example, for a  
temperature decrease of 40 °C (92 °F), a traffic control device such as a low density  
polyethylene barrel would contract by about 0.80%, based on a coefficient of linear  
25 thermal expansion of  $200 \times 10^{-6}$  (m/mK) at 20 °C. For the same temperature change, a  
retroreflective sheeting with a polycarbonate layer would contract by only about 0.23%,  
based on a coefficient of linear thermal expansion of  $57 \times 10^{-6}$  (m/mK) at 20 °C. Thus,  
the barrel contracts almost 3.5 times more than the retroreflective sheeting. Because the  
retroreflective sheeting is wrapped outside of the barrel, conventional sheetings may  
30 wrinkle and lift off the barrel in response to the temperature change. In these situations,  
it is desirable for the retroreflective sheeting to accommodate the differences in thermal

expansion and contraction without compromising retroreflectivity and without lifting off the substrate.

There are basically two types of retroreflective sheeting: beaded and cube-corner sheeting. Beaded sheeting uses a multitude of glass or ceramic microspheres to retroreflect incident light. Because the microspheres are separate from each other, they do not restrict the sheeting's flexibility. However, a cube-corner sheeting typically uses a multitude of rigid, interconnected, cube-corner elements to retroreflect incident light, as shown in U.S. Patent No. 5,450,235 (Smith et al.). Although different types of flexible sheeting are disclosed, none addresses the need to account for the differences in the coefficient of linear thermal expansion between the substrate and the retroreflective sheeting.

One way to produce a stretchable, flexible retroreflective sheeting is disclosed in U.S. Patent No. 3,992,080 (Rowland). That particular sheeting comprises two flexible, stretchable strips of polymeric material. The first strip is a transparent synthetic resin having a multiplicity of minute cube-corner formations on one surface. The second backing strip is of a lesser length than the first strip when both are in a relaxed condition. The backing strip is stretched a predetermined amount, typically 3% to 15%, before being bonded to the first strip of cube-corners. After the bonding process, the backing material is allowed to relax thereby forming a puckered cube-corner sheeting. In the relaxed state, the backing strip is in tension, while the cube-corner strip is in compression, to maintain the puckered appearance of the cube-corner strip. In applying this sheeting to a non-planar surface, such as a bicycle handlebar, the retroreflective sheeting must be stretched to a degree sufficient to eliminate the puckering. However, excessive stretching results in distortion of the cube-corner formations and cause a corresponding loss in retroreflectivity. This loss of retroreflectivity translates into a loss in brightness, causing the sheeting to be less effective as a safety device.

In view of the disadvantages of conventional retroreflective sheetings, it would be desirable to provide a sheeting that accommodates the different rates of expansion and contraction between the polymeric substrate and the sheeting. It is also desirable to provide a sheeting that is not susceptible to brightness loss because of overstretching, or because of other deformations in the cube-corner retroreflective layer.

### Summary of the Invention

The present invention provides a flexible retroreflective sheeting that compensates for dimensional changes in the substrate without sacrificing retroreflectivity. The present invention also eliminates any need to rely on stretching the sheeting to a predetermined length to provide optimal retroreflective performance.

In one embodiment, the present invention includes a microstructured member having a body portion and a multitude of cube-corner elements attached to a first side of the body portion, a sealing member, a network of intersecting lines bonding the first side of the body portion and the sealing members together in a regular pattern of cells, and optionally an adhesive. This retroreflective sheeting exhibits a normal state where the microstructured member is curved and is substantially parallel to the sealing member, and a compressed state where the microstructured member is arched and the sealing member is substantially flat.

In summary, the process of making the retroreflective sheeting includes providing a microstructured member having a body portion and a multitude of cube-corner elements projecting from the first side of the body portion, providing a sealing member, conveying these two members at approximately the same speed with the cube-corner elements facing the sealing member, and bonding the first side of the body portion and the sealing member to each other in a regular pattern to form sealed cells each having a curved microstructured member.

In accordance with this invention, the sheeting is useful for accommodating expansions and contractions of traffic control devices without compromising retroreflectivity and without causing wrinkles in the sheeting. Because of its flexible nature, the sheeting is also useful for applications to polymeric surfaces, irregularly shaped surfaces such as a bicycle helmet, and flexible surfaces such as a safety vest.

### Brief Description of the Drawings

Figure 1 is a cross-sectional view of a cube-corner retroreflective sheeting in a normal state in accordance with the present invention;

Figure 2 is a cross-sectional view of a microstructured member;

Figure 3 is a cross-sectional view of a cube-corner retroreflective sheeting in a compressive state; and

Figure 4 is a schematic representation of a bonding process for making the sheeting of the present invention.

5                   These figures, which are idealized, are not to scale and are intended merely to be illustrative and non-limiting.

#### Detailed Description of the Invention

10                   The inventive retroreflective sheeting allows for expansion and contraction of the traffic control devices without compromising retroreflectivity, without wrinkling, and without delaminating. The sheeting has a pillowed microstructured member. The term "pillowed" as used herein means the member has curvature. This pillowing allows the microstructured member to arch to accommodate the contraction of a traffic control element that occurs when the ambient temperature decreases.

15                   Conversely, the pillowing allows the microstructured member to flatten to accommodate the expansion of a traffic control device when the ambient temperature increases. Furthermore, the pillowed microstructured member allows for some elongation in the sheeting which aids in its application onto traffic control devices. The overall effect of the invention is to provide a versatile retroreflective sheeting that can accommodate for

20                   the differences in expansion and contraction between the device and a sheeting and that is easy to apply onto traffic control devices.

                  The retroreflective sheeting of the present invention exhibits normal and stressed states. A "normal" state represents a condition where neither the microstructured member nor the sealing member is in tension or in compression. In such

25                   a normal state, the microstructured member has curvature and is substantially parallel with the sealing member except where the two are bonded together. The term "parallel" means lines, including curved lines, that are spaced an equal distance apart. The sheeting would typically be in a normal state after fabrication.

                  A "stressed" state represents a condition where the microstructured

30                   member has deviated from its normal state, and is in, for example, a compressed state or an elongated state. A "compressed" state occurs when the microstructured member has arched. An example of a compressed state is where the sheeting contracts in response

to a contraction of the underlying substrate. The sheeting compensates for the contraction by compressing and thereby arching the microstructured member. An “elongated” state occurs when the microstructured member has flattened, eliminating almost all curvature. An example of an elongated state is where the sheeting responds to an expansion of the underlying substrate. The sheeting compensates for the expansion by flattening the microstructured member thereby expanding with the substrate. In both stressed states, the sealing member is substantially flat.

### I. General Structure of the Sheeting

**FIG. 1** shows an example of a microstructured retroreflective sheeting 10 of the present invention in a normal state. Retroreflective sheeting 10 comprises a microstructured member 11 bonded to the first side 26 of sealing member 24 through multiple bond lines 30. As seen in **FIG. 1**, the microstructured and sealing members have similar curvatures and are said to be substantially parallel to each other. The bonding of the two members creates sealed cells 17 containing air. The cells form an array of polygons. Optional adhesive layer 32 with liner 33 may be laminated to the second side 28 of the sealing member 24 to permit the sheeting to be adhered to a surface when the liner has been removed.

**FIG. 2** shows an example of microstructured member 11, taken at 2 in **FIG. 1**, comprising a multitude of cube-corner elements 12 and a body portion 14. The body portion 14 can include a land layer 16 and a body layer 18. The cube-corner elements 12 project from a first or rear side 20 of body portion 14. The cube-corner elements 12 and the body layer 18 comprise light transmissible polymeric materials. Light enters the microstructured member 11 through the front surface 21. The light then passes through the body portion 14 and strikes the mutually perpendicular planar faces 22 of the cube-corner elements 12, and returns in the direction from which it came as shown by arrow 23, as is known in the art.

In a preferred construction, the cube-corner elements 12 and land layer 16 are made from similar or the same kind of polymers, and the land layer 16 is kept to a minimal thickness. The land layer 16, typically, has a thickness in the range of about 0 to 150 micrometers, and preferably in the range of approximately about 1 to 100 micrometers. Body layer 18 typically has a thickness of approximately 20 to 1,000 micrometers, and

preferably in the range of about 50 to 250 micrometers. The cube-corner elements 12 typically have a height in the range of about 20 to 500 micrometers, and more typically in the range of about 60 to 180 micrometers. Although the embodiment of the invention shown in FIG. 2 has a single body layer 18, it is within the scope of the present invention to provide  
5 more than one body layer 18 in the body portion 14.

FIG. 3 shows an example of a microstructured retroreflective sheeting 10' in a stressed state while attached to a traffic control device 50. In particular, the sheeting is in a compressed state wherein the microstructured member has arched in response to a compressive force placed upon it by contraction of the device 50. A temperature decrease is  
10 one example of such a stress. When the ambient temperature decreases, the traffic control device contracts. A desirable sheeting must respond to this contraction without wrinkling, delaminating, or lifting off the substrate. It is believed that as a polymeric traffic control device contracts, the sealing member 24 relaxes slightly and the microstructured member 11 arches upward to accommodate this contraction.

The elimination of wrinkles in the sheeting creates several advantages. For example, the retroreflectivity performance of the sheeting is not compromised because there is no significant distortion of the cube-corner elements. Also, the adhesive on the sheeting and the polymeric substrate remain in contact with each other. Because of this contact, dirt and water cannot come between the adhesive and the substrate, which may cause  
15 delamination of the sheeting. The microstructured and sealing members are discussed in more detail below.

## II. Retroreflective Microstructured Member

The two main elements of the retroreflective microstructured member are the cube-corner formations and the body layer. Both elements include polymers which are light  
25 transmissive, meaning that they are able to transmit at least 70 percent of the light incident upon them. Preferably, these polymers transmit greater than 80 percent and more preferably greater than 90 percent of the incident light. Furthermore, the microstructured member maintains good dimensional stability and high degrees of retroreflectance under highly flexed  
30 conditions.

The cube-corner formations function as the retroreflective mechanism. There are many cube-corner configurations known in the art, *see, for example*, U.S. Patents



4,938,563 (Nelson et al.), 4,775,219 (Appeldorn), 4,243,618 (Van Arnam), 4,202,600 (Burke et al.), 3,712,706 (Stamm), and 4,588,258 (Hoopman). However in the practice of this invention, the cube-corner configuration described in Hoopman may be preferred because it provides wide angle retroreflection along multiple viewing planes.

5           The polymeric materials that are used in the cube-corner elements tend to be hard and rigid and may be thermoplastic. Examples of thermoplastic polymers that may be used in the cube-corner elements include acrylic polymers such as poly(methyl methacrylate); polycarbonates; cellulosics; polyesters; polyetherketones; poly(etherimide); polyolefins; poly(styrene) and poly(styrene) copolymers; polysulfone; urethanes including aliphatic and  
10           aromatic polyurethanes; and mixtures of the above polymers such as a poly(ester) and poly(carbonate) blend, and a fluoropolymer and acrylic polymer blend.

          Additional materials suitable for forming the cube-corner elements are reactive resin systems capable of being crosslinked by a free radical polymerization mechanism by exposure to actinic radiation. Such systems are further described in, for example, U.S.  
15           Patent No. 5,450,235 (Col. 6 lines 34-68; Col. 7, lines 1-48).

          The polymeric materials used to make the land layer may be the same as the polymers that are used to make in the cube-corner elements, provided that the land layer is kept to a minimal thickness. In most instances, the land layer is integral with the cube-corner elements. The polymers that are used in the cube-corner elements and land layer can have  
20           refractive indices which are different from the body layer. Although the land layer desirably is made of a polymer similar to that of the cubes, the land also may be made from a softer polymer such as those used in the body layer.

          The body layer protects the sheeting from the environment, and can provide mechanical integrity to the sheeting. It also gives the sheeting the ability to bend, to curl, or  
25           to flex. Preferred polymeric materials used in the body layer are flexible and resistant to degradation by ultraviolet (UV) light radiation so that the retroreflective sheeting can be used for long-term outdoor applications. Examples of polymers that may be used to make the body layer include fluorinated polymers; ionomeric ethylene copolymers; low density polyethylenes; plasticized vinyl halide polymers; polyethylene copolymers; and aliphatic and  
30           aromatic polyurethanes. Commercially available polyurethanes include: PNO3-214 (from Morton International Inc., Seabrook, New Hampshire) or X-4107 (from B.F. Goodrich Company, Cleveland, Ohio).

Combinations of the above polymers also may be used to make the body layer of the body portion. Preferred polymers for the body layer include: ethylene copolymers that contain units that contain carboxyl groups or esters of carboxylic acids such as poly(ethylene-co-acrylic acid), poly(ethylene-co-methacrylic acid), poly(ethylene-co-vinylacetate);  
5 ionomeric ethylene copolymers; plasticized poly(vinylchloride); and aliphatic urethanes. These polymers are preferred for one or more of the following reasons: suitable mechanical properties, good adhesion to the land layer, clarity, and environmental stability.

Colorants, UV absorbers, light stabilizers, free radical scavengers or antioxidants, processing aids such as antiblocking agents, releasing agents, lubricants, and  
10 other additives may be added to the body portion or cube-corner elements. These components are known in the art, and are further described in, for example, U.S. Patent No. 5,450,235 (Col. 9, lines 46-68 and Col. 10, lines 1-14).

### III. Sealing Member

15 In FIG. 1, the microstructured retroreflective sheeting 10 of the present invention also includes a sealing member 24. The sealing member functions to provide a mechanism to form sealed cells 17 and to protect the cube-corner elements 12.

Examples of polymers that may be used in the sealing member include polyurethanes, polyethylene terephthalate, polyethylene copolymer, alkylene/alkyl  
20 acrylate copolymers such as ethylene/methyl acrylate copolymer, ethylene/N-butyl acrylate copolymer, ethylene/ethyl acrylate copolymer, ethylene/vinyl acetate copolymers, polymerically plasticized polyvinyl chloride (PVC), and polyurethane primed ethylene/acrylic acid (EAA) copolymer. The term "polyurethane" typically includes polymers having urethane and/or urea linkages and such is the intended  
25 meaning herein. Also, polyurethane includes polyether polyurethanes, polyester polyurethanes, and polycarbonate polyurethanes. Blends of such materials may be used if desired.

An example of a suitable EAA material for use in the invention is PRIMACOR™ 3440 (from Dow Chemical Co., Midland, Michigan). It is a copolymer  
30 of ethylene and acrylic acid, the latter present at about 9 weight percent of the total weight of ethylene and acrylic acid monomer; the copolymer has a melt index of about 10.

Polymerically plasticized PVC is considered a distinctly different material from monomerically plasticized PVC because plasticizers from the former will not migrate from PVC. Polymerically plasticized PVC will remain flexible and will not cause deterioration in the optical performance of the retroreflective member.

5 Preferred polymers for the sealing member include polyether polyurethanes, polyester polyurethanes, polycarbonate polyurethanes, all of which may be aliphatic or aromatic. Also, blends of these may be used. A suitable blend comprises between approximately 50 and 99 weight percent aliphatic polyester polyurethane with between approximately 1 and 50 weight percent of a pigmented aromatic polyether  
10 polyurethane. One example of suitable blend comprises 60 weight percent of the aliphatic polyester polyurethane known as MORTHANE™ PNO3-214 (from Morton International, Seabrook, New Hampshire) with 40 weight percent of a pigmented aromatic polyether polyurethane. The pigmented aromatic polyether polyurethane further comprises 50 weight percent aromatic polyurethane known as ESTANE™  
15 58810 (from B.F. Goodrich Co., Cleveland, Ohio) and 50 weight percent titanium dioxide, previously compounded by suitable means, such as in a twin screw extruder and subsequently pelletized. Another example of a suitable polyurethane may be prepared by twin screw compounding between approximately 1 and 50 weight percent of titanium dioxide directly into an aliphatic polyurethane such as MORTHANE™ PNO3-214.  
20 These polymers are preferred for one or more of the following reasons: suitable mechanical properties, environmental stability, ease of processing, and good adhesion to the microstructured member. Suitable thicknesses for the sealing member is between approximately 25 and 200 micrometers and preferably in the range between approximately 50 and 130 micrometers.

25

### III. Methods of Manufacturing

Retroreflective sheetings of the present invention can be made by providing a microstructured retroreflective member having a body portion and a plurality of cube-corner elements projecting from a first side of the body portion;  
30 providing a sealing member; conveying the microstructured member and the sealing member at approximately the speed; and bonding the first side of the body portion and the sealing member to each other in a regular pattern to form sealed cells each having a

curved microstructure member. The microstructured and sealing members may be bonded by thermal or ultrasonic means.

In a thermal bonding process, thermal energy and pressure are used to bond the microstructured and sealing members together. Typically, one member is placed against a steel roll while the other member is placed against a rubber roll. The steel roll, referred to as the "embossing roll," has a raised ridge embossing pattern on its surface. The embossing roll is usually heated to enhance the bond between the two members. The temperature at which the embossing roll is heated to depends on which member it contacts, and can range from between approximately 193 °C and 260 °C (380 °F to 500 °F). Preferably, the temperature range is from between approximately 204 °C and 243 °C (400 °F to 470 °F). The embossing roll and the rubber roll are allowed to come together with the rubber roll exerting pressure against the embossing roll. The pressures commonly used range from between approximately 34 and 136 N/cm (20 to 80 lb<sub>f</sub>/in). The raised ridges bond the two members along a plurality of intersecting bond lines.

**FIG. 4** shows a schematic representation of a thermal bonding process used to produce a preferred embodiment. Microstructured member 11 with its cube-corner elements 12 exposed is unwound from roll 34. Sealing member 24 is unwound from roll 36. Typically, microstructured member 11 is covered with a protective film 13 which is allowed to contact the embossing roll 38 turning at a surface velocity of  $V_1$ . Likewise, sealing member 24 is covered with a protective film 25 which is allowed to contact the rubber roll 42 turning at a surface velocity of  $V_2$ . Velocities  $V_1$  and  $V_2$  are approximately the same. Bonding between the two members occur at raised ridges 40 to form sealed cells. In these cells, there is typically air between the microstructured and sealing members.

The preferred thermal bonding process described in **FIG. 4** is referred to as "front face" bonding, because the embossing roll contacts the front, or microstructured side of the article. As a result of front face bonding, the microstructured member of each cell has curvature and is said to be pillowed. In contrast, if the placement of the members are reversed so that the sealing member contacts the heated embossing roll, the process is referred to as "back face" bonding.

-11-  
09.10.1997

Alternatively, ultrasonic energy may be used in place of thermal energy.

However, the embossing roll would not be heated and the rubber roll would be replaced with a suitable means for supplying ultrasonic energy, such as an ultrasonic horn and a power supply.

5 In either bonding processes, the microstructured member and sealing member are bonded along bond lines that form a regular array of polygons. A suitable polygon allows the microstructured member to grow in curvature or to flatten as a response to a dimensional change of the traffic control devices. Preferred polygons include parallelograms, such as rectangles or squares. The length of the rectangles can  
10 range between approximately 5 and 150 mm (0.2 to 6 in); the width of the rectangles can range from between approximately 5 and 25 mm (0.2 to 1 in). The width is taken to be the longitudinal direction of the sheeting. In one preferred embodiment, the retroreflective sheeting is bonded in a repeating rectangular pattern of 12.7 mm by 8.6 mm (0.50 x 0.34 in).

15 An adhesive may be laminated to one side of the sealing member. Those skilled in the art will recognize that care must be taken in selecting an adhesive that will adequately adhere to polymeric traffic control devices because of their low surface energies. Suitable adhesive may be distinguished by acceptably high shear strength, by acceptably high peel adhesion, and by resistance to delamination after an appropriate  
20 water soak test. One suitable adhesive is a tackified synthetic rubber based pressure sensitive adhesive.

After the retroreflective sheeting is fabricated, it can be applied to polymeric traffic control devices, such as barrels, cones or tubes. A wide variety of polymers may be used to fabricate traffic control devices. Preferably, the traffic control  
25 devices will be selected from a group of polymers that have a coefficient of linear thermal expansion in the range of approximately  $100 \times 10^{-6}$  m/mK and  $250 \times 10^{-6}$  m/mK at 20°C. Furthermore, the ratio of the coefficient of linear thermal expansion between the traffic control device and the retroreflective sheeting is at least 1.5:1 and no greater than 6:1. Preferred polymers for traffic control elements include low density polyethylene, high  
30 density polyethylene, polypropylene, plasticized polyvinyl chloride, and their copolymers.

AMENDED SHEET

The sheeting may be applied to traffic control devices manually or through mechanical means as disclosed in U.S. Patent No. 5,047,107 (Keller et al.). In a manual application, tension is placed on the sheeting as it is being applied to the devices. An advantage of the present invention is that because of the pillowed microstructure member, the sheeting can exhibit some elongation, typically less than 3% with minimal cube-corner distortions. This elongation is enough to allow the sheeting to be guided in a straight line on a traffic control device thereby further enhancing ease of manual application. Because the elongation comes from flattening the pillowed microstructured member, there is minimal cube-corner distortions and thus minimal reduction in brightness.

#### IV. Examples

The following examples illustrate different embodiments of the invention. However, the particular ingredients and amounts used as well as other conditions and details are not to be construed in a manner that would limit the scope of this invention. All percentages are by weight, unless otherwise stated.

##### Example 1 (Comparative)

A retroreflective microstructured member was produced as follows. Molten polycarbonate resin (MARKLON™ 2407 from Mobay Corporation, Pittsburgh, Pennsylvania) was cast onto a heated microstructured nickel tooling containing microcube prism recesses having a depth of about 86 micrometer (0.034 in). These recesses were formed as matched pairs of cube-corner elements with the optical axis canted or tilted 8.15 degrees away from the primary groove, as generally described in U.S. Patent No. 4,588,258 (Hoopman). The nickel tooling thickness was 508 micrometers (0.02 in) and it was heated to 215.6 °C (420 °F). The molten polycarbonate, at a temperature of 287.8 °C (550 °F), was cast onto the nickel tool at a pressure of about  $1.03 \times 10^7$  to  $1.38 \times 10^8$  Pascals (1500 to 2000 psi) for about 0.7 seconds to replicate the microcube recesses. Simultaneously with filling the cube recesses, additional polycarbonate was deposited in a continuous land layer above the tooling with a thickness of about 86 micrometers (0.0034 in). A previously-extruded 64 micrometer (0.025 in) thick aliphatic polyester urethane (MORTHANE™ PNO3-214

from Morton International, Seabrook, New Hampshire) film was laminated onto the top surface of the continuous polycarbonate land when the surface temperature of the land was about 190 °C (375 °F). This aliphatic polyester urethane was protected by a 61 micrometers (0.024 in) thick polyester terephthalate (PET) film. The nickel tooling, along with the polycarbonate and laminated polyurethane, was cooled with room temperature air for about 18 seconds to a temperature between 71 °C and 88 °C (160 °F and 190 °F), allowing the laminate material to solidify to form the microstructured member. This member, having a substantially flat first side and a multitude of cube-corners on the second side, was then removed from the nickel tooling.

10 A sealing member was produced as follows. A blend of 60% aliphatic polyester urethane (MORTHANE™ PNO3-214) and 40% aromatic polyester polyurethane (including 50% aromatic polyester urethane, ESTANE™ 58810 from B.F. Goodrich Co., Cleveland, Ohio and 50% titanium dioxide, previously compounded in a twin screw extruder and pelletized) was extruded. One side of the sealing member was protected by a 51 micrometers (0.002 in) thick PET film.

15 Subsequently, the microstructured and sealing members were fed into a nip at approximately the same speed between a steel embossing roll and a rubber roll having a 75 Shore A durometer. The embossing pattern on the steel roll was of rectangular configuration with dimensions of 0.86 cm by 2.54 cm (0.34 x 1 in).

20 The PET film of the microstructured member was allowed to contact the rubber roll with the cube-cornered side exposed. The PET film of the sealing member was allowed to contact the steel embossing roll with the sealing member exposed (i.e. back face bonding). The steel embossing roll was heated to 216 °C (420 °F). The rolls turned at a speed of 1.52 meters/min (5 feet/min) and the force on the nip was held at 43 N/cm (25 lb/in). As the members passed through the nip, bonds were created between the exposed sealing member and the cube-corners of the microstructured member. Both PET protective films were then removed. A previously coated 63 micrometer (0.0025 in) thick tackified synthetic rubber based pressure sensitive adhesive was laminated to the unbonded side of the sealing member.

30 The resultant retroreflective sheeting had a substantially smooth microstructured top surface. This sheeting was applied manually onto traffic control

device such as a barrel as generally described in U.S. Patent No. 5,026,204 (Kulp et al.). The low density polyethylene barrels (from Traffix Devices Inc., San Clemente, California) are about 4 feet tall and had 5 tapered rings each slightly larger than the next and is molded as one piece. The base of the barrel was molded separately.

5                   The barrels were placed onto a mandrel rotating at 1.52 meters/min (0.5 revolutions/min). They were heated to a surface temperature of 49 °C (120 °F). This heating simulated operating conditions used by some manufacturers who apply retroreflective sheeting after flame-treating the barrels. Immediately after the heating, the sheetings were applied manually to the barrels.

10                   As the barrels cooled to room temperature of about 21 °C (70 °F), the sheeting lifted off the barrel. It is believed that because the sheeting had a smooth microstructured member, one way for the sheeting to respond to the barrel contracting was buckling and lifting off the substrate thereby forming wrinkles.

15                   Consequently, rain and dirt can accumulate behind these wrinkled areas and promote them causing a reduction in brightness. As the wrinkles get promoted, there may be regions where the sheeting delaminates from the barrels.

#### Example 2

                  The microstructured and sealing members were made in accordance with Example 1 except as described below.

20                   The PET film of the microstructured member was allowed to contact the steel emboss roll with the cube-cornered side exposed (front face bonding). The PET film of the sealing member was allowed to contact the rubber roll with the sealing member exposed as shown in FIG. 4. The steel embossing roll was heated to 243 °C (470 °F). The rolls turned at a speed of 1.52 meters/min (5 feet/min) and the force on the nip was held at 86 N/cm (50 lb/in) to create bonds between the cube-corners and the  
25                   exposed sealing member. Both PET films were then removed. A previously coated 0.3 micrometer (0.0025 in) thick tackified synthetic rubber based pressure sensitive adhesive was laminated to the unbonded side of the sealing member.

30                   The resultant retroreflective sheeting had a substantially pillowed or curved microstructured member. The sheeting was laminated to a barrel as generally



described in Example 2. As the barrels cooled to room temperature of about 21 °C (70 °F), the sheeting remained secured to the barrel. It is believed that the pillows changed their shaped and arched to accommodate for the contraction of the barrel.

5 Measurements of the dimensions of the pillows were made to determine the growth in curvature. The two dimensions measured included the height of the pillows and the base of the pillows. The base is taken to be the length one side of the rectangle. The height represented the distance from the midpoint of the base to the top of the microstructured member.

**Table 1**

Sheeting State	Height (cm)	Base (cm)	Ratio (H to B)
normal	0.051	1.27	0.040
compressed	0.11	1.26	0.081

10

Referring to **Table 1**, the “normal” state referred to a sheeting of this example after adhesive lamination; the “compressed” state referred to the sheeting applied on a barrel that had seen a temperature change from 49 °C to 4 °C (120 °F to 40 °F). As **Table 1** shows, the height to base ratio approximately doubled as the sheeting  
 15 changed from a normal to a compressed state in response to the contraction of the barrel resulting from the temperature decrease.

This invention may take on various modifications and alterations without departing from the spirit and scope thereof. Accordingly, it is to be understood that this invention is not to be limited to the above-described but is to be controlled by the  
 20 limitations set forth in the following claims and any equivalents thereof.

PCT/US97/04041  
Minnesota Mining and Manufacturing Co.  
Our Ref.: B 2473 PCT

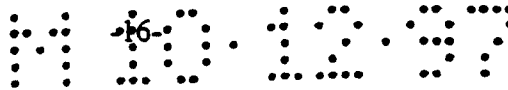

I claim:

1. A method of making a pillowed retroreflective article comprising the steps of:
  - (a) providing a microstructured retroreflective member having a body portion and a plurality of cube-corner elements projecting from a first side of said body portion;
  - (b) providing a sealing member;
  - (c) conveying said microstructured member and said sealing member at substantially the same speed, such that the sealing member is substantially tensionsless relative to the microstructured member, and such that said cube-corner elements face said sealing member; and
  - (d) bonding said first side of said body portion and said sealing member to each other in a regular pattern to form sealed cells each having a curved microstructured member.
2. The method of claim 1 wherein step (d) comprises thermal bonding.
3. The method of claim 2 wherein said thermal bonding process comprises a bonding temperature of between approximately 193 °C and 260 °C.
4. The method of claim 2 wherein said thermal bonding process comprises a bonding pressure of between approximately 34 N/cm and 136 N/cm.
5. The method of claim 2 wherein said thermal bonding process comprises a bonding temperature of between approximately 204 °C and 243 °C and a bonding pressure of between approximately 34 N/cm and 136 N/cm.
6. The method of claim 1 wherein step (d) comprises ultrasonic bonding.
7. The method of claim 1 wherein step (d) comprises front face bonding.
8. The method of claim 1 wherein said regular pattern comprises an array of polygons.

PCT/US97/04041

Minnesota Mining &amp; Manufacturing Co.

Our Ref.: B 2473 PCT

-17-

March 5, 1998  
VOSSIUS & PARTNER  
PATENTANWÄLTE  
SIEBERTSTR. 4  
81675 MÜNCHEN

9. The method of claim 8 wherein said polygons comprise rectangles.
10. The method of claim 9 wherein said rectangle has a length of between approximately 5 and 150 mm.
11. The method of claim 9 wherein said rectangle has a width of between approximately 5 and 25 mm.
12. A retroreflective sheeting comprising:
- (a) a microstructured retroreflective member having a body portion and a plurality of cube-corner elements projecting from a first side of said body portion;
  - (b) a sealing member; and
  - (c) a network of intersecting lines bonding said first side of said body portion and said sealing member to each other in a regular pattern of cells wherein the retroreflective sheeting is adapted such that it can elongate by up to 3% with minimal distortion of the cube-corner elements and that it is changeable between:
    - (i) a normal state wherein said microstructured member is curved and is substantially parallel to said sealing member; and
    - (ii) a compressed state wherein said microstructured member is arched and said sealing member is substantially flat.
13. The article of claim 12 wherein said body portion comprises a body layer.
14. The article of claim 13 wherein said body layer comprises polymers that are flexible and ultraviolet light absorbing.

1405-03-90

15. The article of claim 12 wherein said cube-corner elements comprise polymers selected from the group consisting of acrylic, polycarbonate, polyester, polyurethane, and crosslinked acrylates.

16. The article of claim 12 wherein said sealing member comprises polymers selected from the group consisting of polyurethane, polyethylene terephthalate, polyethylene copolymers, ethylene methyl acrylate copolymer, ethylene ethyl acrylate copolymer, ethylene vinyl acetate copolymer, and polyvinyl chloride containing a polymeric plasticizer.

17. A retroreflective traffic control device comprising:

(a) a polymeric device; and

(b) the retroreflective sheeting of claim 12 bonded to an outer surface of the device such that as said polymeric device contracts in response to decreasing ambient temperature said microstructured member arches, and as said polymeric device expands in response to increasing ambient temperature said microstructured member flattens.

18. The device of claim 17 wherein said polymeric device comprises polymers selected from a group consisting of low density polyethylene, high density polyethylene, polypropylene, plasticized polyvinylchloride, and their copolymers.

19. The device of claim 17 wherein said polymeric device comprises polymers having a coefficient of linear thermal expansion of between approximately  $100 \times 10^{-6}$  m/mK and  $250 \times 10^{-6}$  m/mK at 20°C.

AMENDED SHEET

M O S . O S . S O

20. The device of claim 19 wherein the ratio of said coefficient of linear thermal expansion for said polymeric device to said retroreflective sheeting is about 1.5:1 to about 6:1.

21. The device of claim 17 wherein said retroreflective sheeting is bonded adhesively to said polymeric device.

22. The device of claim 21 wherein said adhesive is a tackified synthetic rubber based pressure sensitive adhesive.

23. The device of claim 17 wherein said polymeric device is a polyethylene traffic barrel.

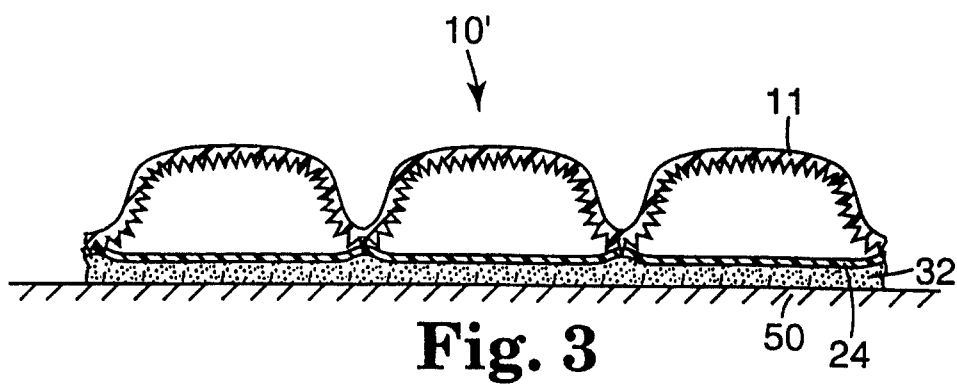
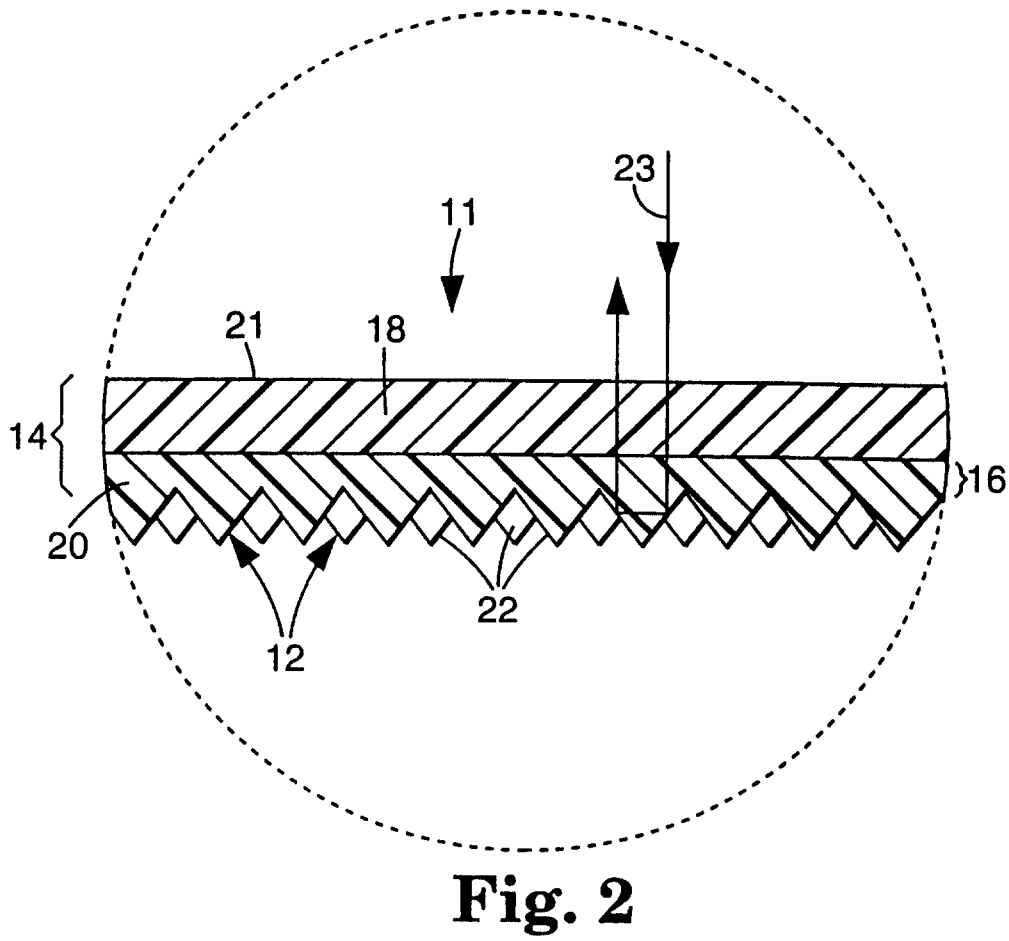
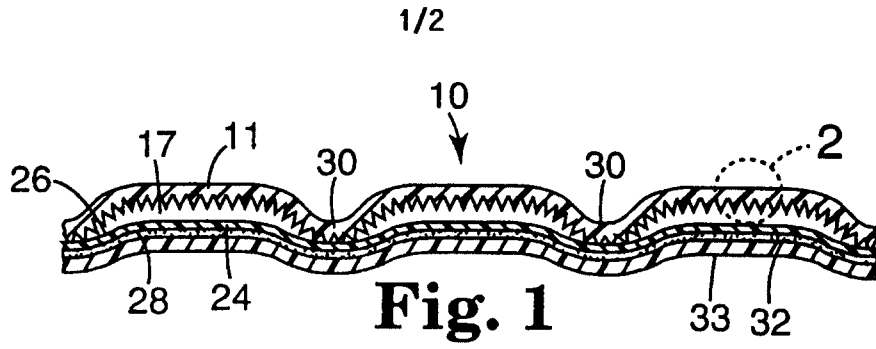

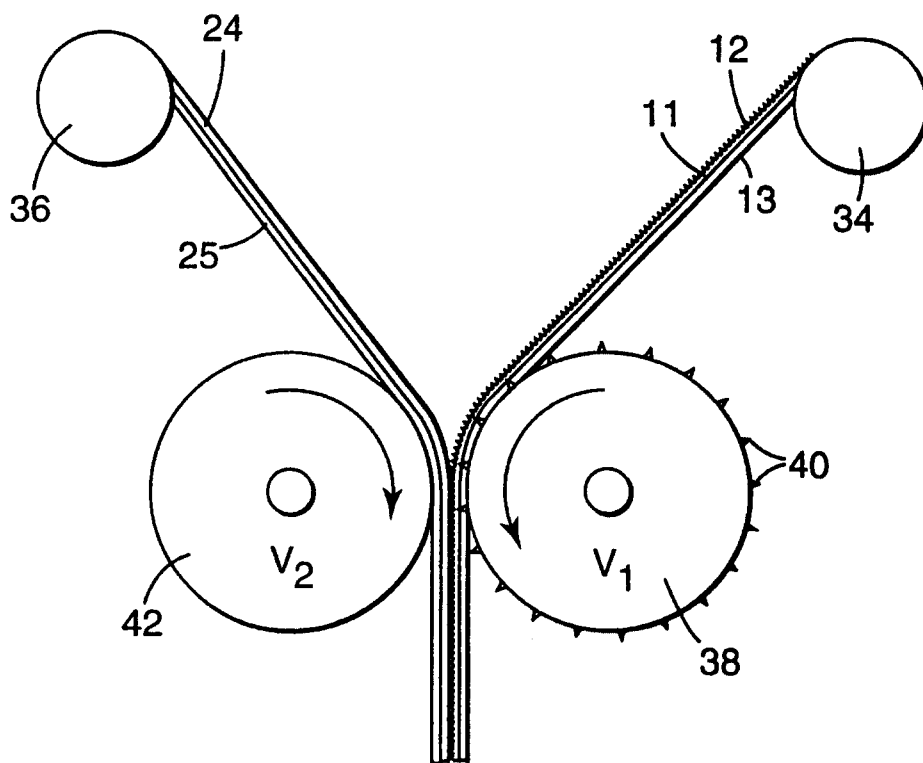

**Fig. 4**

