

Aug. 8, 1933.

W. A. ROTH

1,921,043

AIRPLANE

Filed Sept. 22, 1930

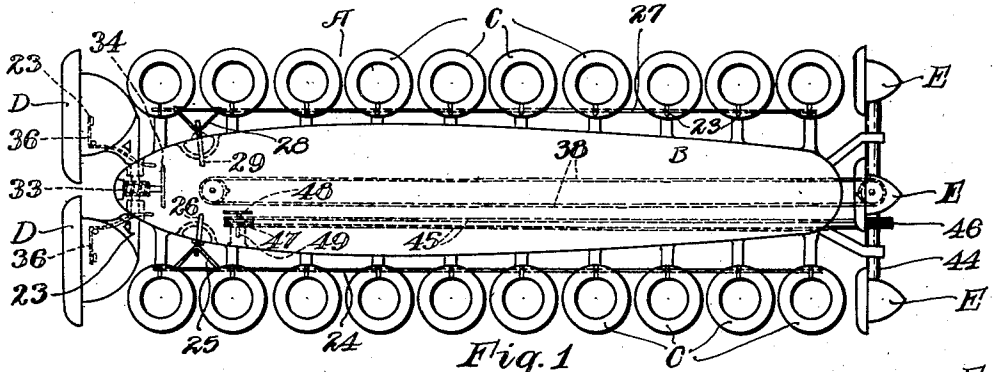

Fig. 1

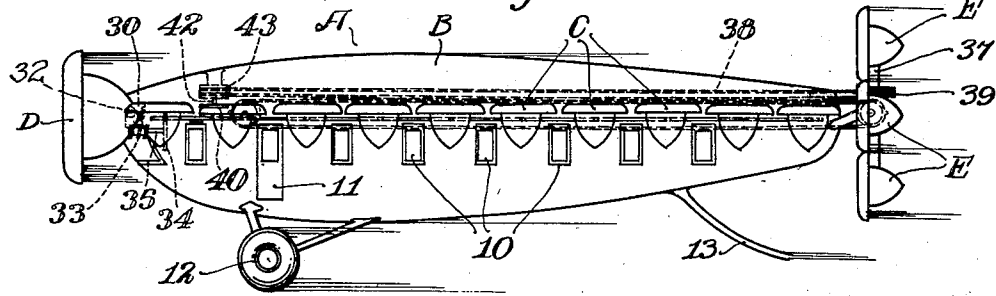

Fig. 2

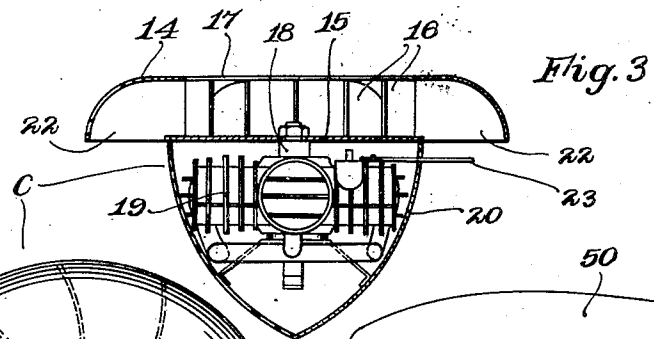

Fig. 3

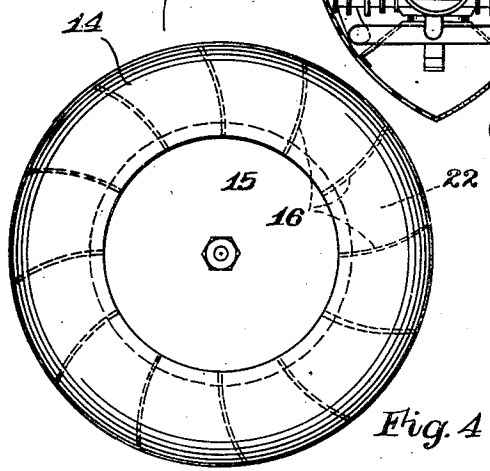

Fig. 4

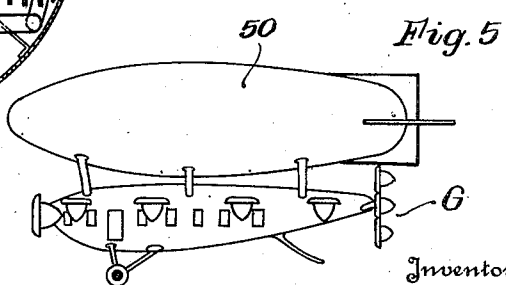

Fig. 5

Inventor  
William A. Roth

By Hon. Fischer  
Attorney

# UNITED STATES PATENT OFFICE

1,921,043

## AIRPLANE

William A. Roth, St. Paul, Minn., assignor of  
two-thirds to Trew F. Poole, St. Paul, Minn.,  
and Henry J. Roth, New London, Minn.

Application September 22, 1930  
Serial No. 483,503

9 Claims. (Cl. 244—18)

My invention relates to airplanes, of a type particularly adapted to rise vertically in the air and descend in the same manner.

It is an object of my invention to provide an airplane which may be operated to rise vertically in the air, may travel horizontally on an inclined plane, or may be operated to hold itself suspended virtually motionless with relation to the earth.

It is the object of my invention to equip the fuselage of my plane with a number of rotor planes, preferably in rows along the sides of the fuselage, and to provide means of controlling the motors within these rotor planes. Each controlling means is associated with all of the rotor planes of one row so that all of the rotor plane motors in each row are controlled as a unit. Thus, if the rotor planes are arranged with the rows extending parallel with, and oppositely disposed to, the fuselage of the airplane, the airplane may be tilted by increasing the speed of rotation of the rotor planes in the row on one side of the fuselage and decreasing the speed of the rotor planes in the row on the opposite side of the same.

It is a further object of my invention to provide a pair of rotor planes at the front end of the fuselage, which is adapted to draw the airplane in a horizontal direction. These last mentioned rotor planes are capable of being tilted, and thus, may be used for aiding the rising of the airplane in a vertical direction, may pull the airplane in a horizontal direction, or may be tilted to aid both in the rising of the plane and in the drawing of the same forwardly.

It is a further object of my invention to provide two pairs of control rotor planes secured adjacent the rear end of the airplane. One pair of these planes is secured upon a vertical axis, and is rotatable thereupon. The other pair of rotor planes is held rotatable upon a horizontal axis. These planes are capable of turning the plane or of varying the slope on which the plane is moving. By proper manipulation of these controls, the airplane may be easily maneuvered.

It is a further object of my invention to provide the rotor planes with individual motors, each capable of developing a high speed of rotation. In this manner, air may be drawn through the same, removing the resistance of the plane by removing the air from the front of the rotor plane, and forcing this air out the back of the rotor plane at a high rate of speed to impel the plane forward.

The rotor planes and their motors may be used

in combination with the dirigible type of airship. In this modification, the body of the airship may be of the dirigible type and have sufficient buoyancy to help raise the same from the ground. When used in this manner, it will not be necessary to use so many rotors.

Other objects and novel features of my invention will be more clearly and fully set forth in the following specification and claims.

In the drawing forming a part of this specification:

Figure 1 is a plan view of my airplane.

Figure 2 is a side elevation view of the same.

Figure 3 is a cross-sectional view through the center of one of the rotor planes.

Figure 4 is a plan view of one of the rotor planes.

Figure 5 shows a dirigible type of airship and rotor planes.

My airplane A is provided with a fuselage E having windows 10 through which the pilot may see to guide the airplane, and a door 11 offering a means of entrance and exit. This fuselage B may be equipped with a pair of wheels 12 by which the airplane may be wheeled from place to place upon the ground, the rear of the fuselage being supported by means of a tail skid 13. The wheels 12 are not necessary except for convenience in transporting the plane when on the ground, and when desirable may be omitted, being replaced with shock absorbing skids or legs.

Secured upon either side of the fuselage B are a number of rotor planes C. These rotor planes are formed preferably as illustrated in the drawing. An inverted saucer-like cover member 14 is integrally secured to a disc member 15 by means of a number of arcuated vanes 16. The cover member 14 is provided with an opening 17 in the center portion of the same, for the purpose of admitting air into the rotor plane. The disc-like backing plate 15 is of a diameter somewhat smaller than that of the cover member 14, and is held by the vanes 16 spaced from the cover member and on the same plane as the outer peripheral edge thereof, leaving an annular opening between the disc-like backing plate 15 and the outer edge of the cover member 14 whereby the air from the rotor plane may be emitted.

Secured to the disc-like backing plate 15 against turning, I provide the motor shaft 18 of the motor 19. A stream lined casing 20 encloses the motor 19 to prevent undue air resistance. The entire rotor plane C is rotated by means of the shaft 18, the air therein being forced through the opening 22 in the rear of the same and allow-

ing more air to enter through the opening 17 in the cover member 14. Thus, as the rotor plane attains a high rate of speed, the air is pulled with great force into the opening 17 in the front of the plane and forced swiftly out the rear thereof, tending to pull the rotor plane through the air at a high rate of speed.

As has been stated hereinbefore, the rotor planes are arranged in rows on opposite sides of the fuselage of the airplane. Each row is equipped with a means of controlling all of the rotor planes in that row. In the drawing, a lever 23 is secured to the gasoline supply line in such a manner as to act as a throttle valve for the motor. Movement of the lever 23 in one direction tends to increase the speed of the motor, and movement in the other direction tends to decrease the speed of the same. All of the levers 23 on each of the rotor planes on one side of the fuselage B are secured to a rod 24 which is secured to a bracket 25 connected to a lever 26 within the fuselage B of the plane, so that the motors 19 within the rotor planes C on that particular side may be speeded up or slowed down at will. The levers 23 of each of the rotor planes on the opposite side of the fuselage B are connected to a rod 27 which is provided with a bracket 28 connected with a lever 29 in such a manner that the lever 29 may be operated from within the fuselage B to operate the levers 23 to increase or decrease the speed of the motors 19 within the rotor planes on that side of the fuselage B.

At the front end of the plane, secured upon a horizontal shaft, I provide a pair of rotor planes D, which are similar in construction to the rotor planes C, but are preferably somewhat larger in diameter. A gear segment 30 on the shaft 32 to which the rotor planes are secured may be operated by means of a worm gear 33, and by turning the worm gear by means of the operating wheel 34 on the worm gear shaft 35, the rotor planes D may be tilted upwardly to assist in the lifting action of the planes C. Each of the rotor planes D is provided with separate mechanism 36 for operating the throttle levers 23 thereupon, so that these rotors D may be controlled individually to assist in the maneuvering of the airplane A.

In order to enable the operator of the airplane to control every movement of my airplane A, I have provided a novel rear control apparatus. A pair of rotor planes E, similar in construction to the rotor planes C and D, are secured against turning upon a vertical shaft 37. This shaft 37 is held in such a manner that the entire shaft 37 and rotor planes E secured thereto may be rotated about the axis of the shaft. The rotation of this shaft 37 is accomplished by means of a cable 38, which is wound around and fastened to a pulley 39 upon the shaft 37. The cable 38 is operated to rotate the pulley 39 by means of a hand wheel 40, secured integrally upon the shaft 42 of a pulley 43 about which the cable 38 is wound and fastened. The hand wheel is placed in a convenient position in the control room of the airplane A.

In a similar manner, two rotor planes E are secured upon a horizontal shaft 44, which may be rotated by the cable 45, stretched between the pulleys 46 and 47. The cable 45 is motivated by the hand wheel 48 attached to the shaft 49 of the pulley 47. By operating the rotor planes E in the proper manner, the direction of these rotor planes is changed to turn or elevate the airplane.

The dirigible type of my airship will operate in a very practical manner. Rotor planes are used

with this type of airship, as may be seen in Figure 5 of the drawing, and the same may be controlled in a manner similar to the method of controlling the airplane A, as described hereinbefore. In the dirigible type of airship G, the body portion 50 is of sufficient size, and contains sufficient buoyancy to aid the rotor planes in lifting the same. In this combination, fewer rotor planes are necessary, and only a number of rotors necessary for lifting the airship G from the ground and maintaining a proper level in the air are provided. It may be seen that it is possible to move the airship vertically, horizontally, or at any inclined angle, as desired.

The operation of my airplane is believed obvious from the foregoing description. The various motors in all of the rotor planes are started by any suitable means. The rotor planes C rotate at a high rate of speed to lift the airplane from the ground in a vertical direction. If it is desired, the rotor planes D may be tilted to a horizontal position to aid in lifting the airplanes from the ground. The rotor planes E upon the horizontal shaft 44 may also be turned horizontally to assist in lifting the airplane A. The airplane is stabilized by controlling the speed of rotation of the rotor planes C on each side of the fuselage B. When the desired height is reached to allow the airplane to move forwardly, the rotor planes D may be tilted to pull the airplane in a horizontal direction, the rotor planes C holding the airplane suspended in the air. The plane may be maneuvered by manipulating the various controls.

While I have described a particular method of controlling the speed and direction of the various rotor planes, I desire to have it understood that this is only illustrative of a means of carrying out my invention, and that obvious changes may be made within the scope of the following claims without departing from the spirit of the invention.

I claim:

1. An airship consisting of a fuselage, a series of rotor planes mounted about said fuselage, means for controlling said rotor planes to cause said fuselage to be raised in the air, a separate motor for each of said rotor planes, a casing for each of said motors secured to said fuselage, and means for tilting some of said rotor planes to cause the airship to be operated in the desired direction.

2. An airship including, a dirigible balloon, a cabin portion carried by said balloon, a series of rotor planes mounted in a manner in relation to said cabin and balloon to assist said balloon in lifting said cabin and balloon in the air off of the ground, means for tilting some of said rotor planes to provide motive power for moving said airship through the air and a series of rotor planes for steering said balloon.

3. An airship including, a body portion adapted to house the passengers and operators, a series of horizontally disposed rotor motor planes having self-contained motors mounted along each side of said body portion, means for controlling said series of rotor planes, said rotor planes being adapted to elevate said airship off of the ground, and propelling and guiding rotor planes having self-contained motors carried by said body portion.

4. A rotor plane for an airship including, a rotor having a series of air vanes mounted in the head thereof, a body portion depending from said rotor plane, and an operating motor for said

vanes mounted in said body portion depending below said rotor plane.

5 5. A rotor plane for airships including, a rotatable air fan made up of a series of air blades, a casing over said air fan having a central opening to receive air therethrough, and a circumferential lower opening to expel air therefrom, an operating motor for said rotor plane, a housing depending from said casing for enclosing said motor, said motor including motive means for operating said air blades in said rotor plane to cause air to be drawn in through the center of said rotor plane and expelled around the periphery of the lower side thereof.

10 15 6. A rotor plane and motor unit for airships including, a circular casing, an opening in the center of said casing at the top thereof, a peripheral opening in the bottom of said casing extending annularly thereabout, a rotating air fan within said casing, an acorn-shaped housing depending below said casing, a motor mounted within said housing for operating said air fan to provide a rotor plane for airships.

20 25 7. A rotor plane for airships of a unitary type including, a casing, a rotating fan within said casing, a unitary casing depending from said fan casing having an inverted bee-hive type forma-

tion and a motor for operating said fan contained within said depending casing, a central intake opening in the top of said fan casing, and an exhaust opening in the bottom around said motor casing.

8. A rotor plane for airships including, a rotatable air fan made up of a series of air blades, a casing over said air fan having a central opening to receive air therethrough, a circumferential lower opening to expel the air therefrom, a motor connected to said casing including motive means for operating said air blades in said rotor plane to cause air to be drawn in through said central opening and expelled through said circumferential opening.

9. A rotor plane for airships including, a casing, a rotatable fan within said casing, a central intake opening on one side of said casing, a circumferential exhaust opening through the other side of said casing, a motor and means for supporting said motor, and means for connecting said motor with said casing whereby said casing is rotated to draw air through said central opening and exhaust air through said circumferential opening.

WILLIAM A. ROTH.

30	105
35	110
40	115
45	120
50	125
55	130
60	135
65	140
70	145
75	150