

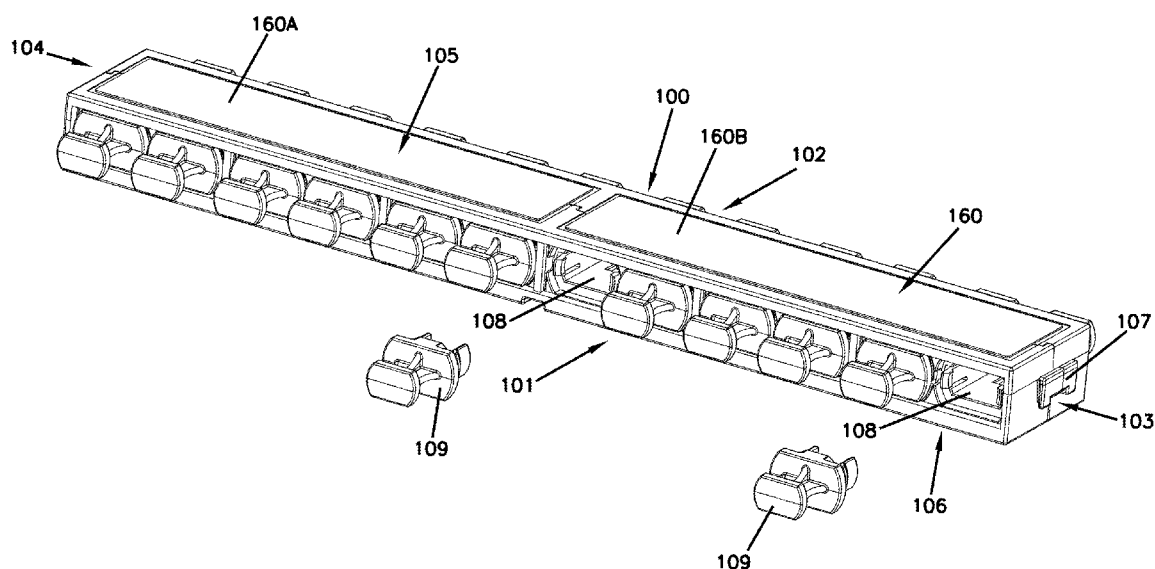

- (51) International Patent Classification:  
*G02B 6/38* (2006.01)
- (21) International Application Number:  
PCT/US2017/052501
- (22) International Filing Date:  
20 September 2017 (20.09.2017)
- (25) Filing Language: English
- (26) Publication Language: English
- (30) Priority Data:  
62/397,449 21 September 2016 (21.09.2016) US
- (71) Applicant: **COMMSCOPE TECHNOLOGIES LLC**  
[US/US]; 1100 CommScope Place SE, Hickory, North Carolina 28602 (US).
- (72) Inventors: **SIEVERS, Scott C.**; 925 Waterford Way, Jordan, Minnesota 55352 (US). **MATTSON, Loren J.**; 6609 Emerson Avenue, Richfield, Minnesota 55423 (US).
- (74) Agent: **BRUESS, Steven C.**; MERCHANT & GOULD P.C., P.O. Box 2903, Minneapolis, Minnesota 55402-0903 (US).
- (81) Designated States (*unless otherwise indicated, for every kind of national protection available*): AE, AG, AL, AM, AO, AT, AU, AZ, BA, BB, BG, BH, BN, BR, BW, BY, BZ, CA, CH, CL, CN, CO, CR, CU, CZ, DE, DJ, DK, DM, DO, DZ, EC, EE, EG, ES, FI, GB, GD, GE, GH, GM, GT, HN, HR, HU, ID, IL, IN, IR, IS, JO, JP, KE, KG, KH, KN, KP, KR, KW, KZ, LA, LC, LK, LR, LS, LU, LY, MA, MD, ME, MG, MK, MN, MW, MX, MY, MZ, NA, NG, NI, NO, NZ, OM, PA, PE, PG, PH, PL, PT, QA, RO, RS, RU, RW, SA, SC, SD, SE, SG, SK, SL, SM, ST, SV, SY, TH, TJ, TM, TN, TR, TT, TZ, UA, UG, US, UZ, VC, VN, ZA, ZM, ZW.
- (84) Designated States (*unless otherwise indicated, for every kind of regional protection available*): ARIPO (BW, GH, GM, KE, LR, LS, MW, MZ, NA, RW, SD, SL, ST, SZ, TZ, UG, ZM, ZW), Eurasian (AM, AZ, BY, KG, KZ, RU, TJ, TM), European (AL, AT, BE, BG, CH, CY, CZ, DE, DK, EE, ES, FI, FR, GB, GR, HR, HU, IE, IS, IT, LT, LU, LV, MC, MK, MT, NL, NO, PL, PT, RO, RS, SE, SI, SK, SM,

(54) Title: ADAPTER BLOCK ASSEMBLY

FIG. 1



(57) Abstract: An adapter block assembly includes two housing pieces that cooperate to hold one or more adapters therebetween. The two housing pieces are removably latched together. Labels can be placed over the latches. Certain types of adapter block assemblies are configured to receive multi-fiber plug connectors. Certain types of adapter block assemblies include securement arrangements at opposite ends thereof to aid in mounting the adapter block assemblies to frames, trays, chassis, or other such structures.



TR), OAPI (BF, BJ, CF, CG, CI, CM, GA, GN, GQ, GW,  
KM, ML, MR, NE, SN, TD, TG).

**Published:**

— *with international search report (Art. 21(3))*

## **ADAPTER BLOCK ASSEMBLY**

### **Cross-Reference to Related Application**

This application is being filed on September 20, 2017 as a PCT  
5 International Patent Application and claims the benefit of U.S. Patent Application Serial  
No. 62/397,449, filed on September 21, 2016, the disclosure of which is incorporated  
herein by reference in its entirety.

### **Background**

As demand for telecommunications increases, fiber optic networks are  
10 being extended in more and more areas. Management of the cables, ease of installation,  
and ease of accessibility for later management are important concerns. As a result, there is  
a need for fiber optic devices and methods which address these and other concerns.

### **Summary**

Some aspects of the disclosure are directed to an adapter block assembly  
15 that is elongated along a length between a first end and a second end. The adapter block  
assembly has a first port side and an opposite second port side that each extends along the  
length between the first and second ends. The adapter block assembly includes a first  
housing piece and a second housing piece. The first housing piece extends along the  
length between the first and second ends. The first housing piece defines the first port  
20 side. The first housing piece also includes a first portion of a retention arrangement. The  
second housing piece extends along the length between the first and second ends. The  
second housing piece defines the second port side. The second housing piece also  
includes a second portion of a retention arrangement. The second portion is configured to  
mate with the first portion to hold the first and second housing pieces together. The first  
25 and second housing pieces cooperate to define an interior when the first and second  
housing pieces are held together.

In certain implementations, an adapter fits within the interior.

In certain implementations, the adapter is one of a plurality of adapters that  
fit within the interior.

30 In certain implementations, the adapters fit within the interior in a row.

In certain implementations, the adapter is configured to receive and align two multi-fiber connectors.

In certain implementations, the adapter is a duplex adapter configured to receive and align two pairs of multi-fiber connectors.

5 In certain implementations, the first portion of the retention arrangement includes a latch arm and the second portion of the retention arrangement includes a latch receptacle sized to receive the latch arm.

10 In certain implementations, the first portion of the retention arrangement includes a plurality of latch arms and the second portion of the retention arrangement includes a plurality of latch receptacles. Each latch receptacle is sized to receive a corresponding one of the latch arms.

In certain implementations, the first portion of the retention arrangement includes a first latch arm and a first latch receptacle and the second portion of the retention arrangement includes a second latch arm and a second latch receptacle sized to receive the first latch arm. The first latch receptacle is sized to receive the second latch arm.

In certain implementations, each portion of the retention arrangement includes a plurality of latch arms and a plurality of latch receptacles.

In certain implementations, the first housing piece is identical to the second housing piece.

20 In certain implementations, the first and second retention walls cooperate to define first and second non-port sides of the adapter block assembly when the second housing piece is held to the first housing piece. At least one of the non-port sides defines a recessed area at which a label can be disposed.

25 In certain implementations, a label attached to the first non-port side to cover at least part of the first and second portions of the retention arrangement.

In certain implementations, a first securement arrangement disposed at the first end of the adapter block assembly and a second securement arrangement disposed at the second end of the adapter block assembly.

30 In certain implementations, each of the securement arrangements includes a first part disposed at the first housing piece and a second part disposed at the second housing pieces. The first part cooperates with the second part to form the respective securement arrangement when the first housing piece is held to the second housing piece.

In certain implementations, the first securement arrangement is fully formed by the first housing piece and the second securement arrangement is fully formed by the second housing piece.

5 In certain implementations, each securement arrangement includes a latching hook.

Other aspects of the disclosure are directed to a fixture for use in assembling an adapter block assembly. The fixture includes a body including a base that is elongated along a length between a first end and a second end; and alignment members disposed in a row along the base and extending upwardly from the base. Each alignment member is sized to fit within a port of an adapter.

10 In certain implementations, a first alignment guide extends upwardly from the base at the first end. In certain examples, a second alignment guide extends upwardly from the base at the second end.

In certain implementations, each alignment member includes a key member sized and is shaped to fit within a keyway defined by a respective port of an adapter.

In certain implementations, an adapter block assembly is mounted to the fixture.

In certain implementations, a first housing piece is mounted to the fixture.

20 In certain implementations, an adapter is mounted over the first housing piece so that one of the alignment members extends into a port defined by the adapter.

In certain implementations, sides of the fixture that extend between the first and second ends are sufficiently low to the base to enable labels to be added to the adapter block assembly without removing the adapter block assembly from the fixture.

25 In certain implementations, the fixture includes indicia that indicate a rotational orientation of the adapter block assembly.

Other aspects of the disclosure are directed to a method of assembling of adapter block assembly. The method includes mounting a first housing piece onto a fixture. The first housing piece has a first port side facing a base of the fixture. The fixture includes an alignment member that extends upwardly through an aperture defined in the first port side of the first housing piece.

In certain implementations, the method also includes mounting an adapter to the fixture over the first housing piece. The adapter defines a port. The adapter is mounted so that the alignment member of the fixture extends into the port.

In certain implementations, the method also includes mounting a second housing piece over the adapter so that the adapter is disposed within a cavity defined by the first and second housing pieces; and securing the second housing piece to the first housing piece to form an adapter block assembly.

5 In certain implementations, the alignment member includes a key that fits with a keyway defined at the port to rotationally orient the adapter relative to the fixture.

In certain implementations, the method also includes applying a label to a first non-port side of the adapter block assembly without removing the adapter block assembly from the fixture.

10 In certain implementations, the method also includes rotating the fixture and the adapter block assembly to lay an opposite second non-port side on a surface prior to applying the label to the first non-port side. The fixture is rotated based on indicia identifying the first non-port side.

In certain implementations, the method also includes rotating the fixture  
15 and the adapter block assembly to lay the first non-port side on the surface; and applying a second label to the second non-port side.

A variety of additional inventive aspects will be set forth in the description that follows. The inventive aspects can relate to individual features and to combinations of features. It is to be understood that both the forgoing general description and the  
20 following detailed description are exemplary and explanatory only and are not restrictive of the broad inventive concepts upon which the embodiments disclosed herein are based.

### **Brief Description of the Drawings**

The accompanying drawings, which are incorporated in and constitute a part of the description, illustrate several aspects of the present disclosure. A brief  
25 description of the drawings is as follows:

FIG. 1 is a first port side perspective view of an example adapter block assembly configured in accordance with the principles of the present disclosure;

FIG. 2 is a second port side perspective view of the example adapter block assembly of FIG. 1;

30 FIG. 3 is a perspective view of the adapter block assembly of FIG. 1 with the components exploded from each other;

FIGS. 4 and 5 are perspective views of an example housing piece suitable for use with the adapter block assembly of FIG. 1;

FIG. 6 is a perspective view of an example adapter suitable for use with the adapter block assembly of FIG. 1;

FIG. 7 is a cross-sectional view of the adapter block assembly of FIG. 1 with one of the adapters removed for ease in viewing interior features of the housing pieces; and

FIGS. 8-15 illustrate steps of assembling the adapter block assembly using a fixture.

### **Detailed Description**

Reference will now be made in detail to exemplary aspects of the present disclosure that are illustrated in the accompanying drawings. Wherever possible, the same reference numbers will be used throughout the drawings to refer to the same or like parts.

The present disclosure is directed to an adapter block assembly having a first port side and an opposite second port side. Each port side defines one or more ports that align with the one or more ports on the opposite side. The adapter block assembly includes first and second securement arrangements at opposite ends to facilitate mounting the adapter block assembly to a frame, tray, drawer, rack, chassis, or other such structure. The adapter block assembly is assembled so as to be handled as a unit. Any plug connectors received at the ports are carried with the adapter block assembly.

FIGS. 1 and 2 illustrate an example adapter block assembly 100 structured and configured in accordance with the principles of the present disclosure. The adapter block assembly 100 is elongated along a length between a first end 103 and a second end 104. The adapter block assembly 100 has a first port side 101 and an opposite second port side 102 that each extend along the length between the first and second ends 103, 104. One or more connection ports 108 are defined at each port side 101, 102. The ports 108 align optical plug connectors received at the opposite port sides 101, 102. Each port 108 can receive a dust cap 109 when not in use (i.e., when a plug connector is not received at the port 108).

Opposite non-port sides 105, 106 extend between the port sides 101, 102 and between the first and second ends 103, 104. In certain examples, the non-port sides 105, 106 have more surface area than the port sides 101, 102. In certain examples, labels or other indicia can be provided at one or both of the non-port sides 105, 106. In certain examples, portions of the non-port sides 105, 106 are recessed (see 115) to accommodate the labels without increasing a footprint of the adapter block assembly 100.

In certain examples, indicia can be provided on the first non-port side 105 in alignment with the ports 108 to provide port identification. In the example shown in FIG. 1, a first adhesive port label 160A is disposed on the first non-port side 105 across a first set of ports 108 and a second adhesive port label 160B is disposed on the first non-port side 105 across a second set of ports 108. In other examples, however, the port labels 160 can be held by a transparent cover, molded into, silk screened onto, or otherwise disposed at the non-port side 105. As shown in FIG. 2, a block label 165 can be disposed elsewhere on the adapter block assembly 100, such as on the second non-port side 106. The block label 165 can provide identification for the adapter block 100. As with the first label 160, the block label 165 can be held by adhesive, a transparent cover, or can be silk screened or molded onto the adapter block 100.

In certain implementations, a securement arrangement 107 can be disposed at the first end 103. The securement arrangement 107 is configured to engage mounting structure on a tray, drawer, frame, chassis, blade, or other retention structure to hold the adapter block assembly 100 at the retention structure. In certain examples, the securement arrangement 107 is a first securement arrangement and a second securement arrangement 107 can be provided at the second end 104. In the example shown, the first securement arrangement 107 is identical to the second securement arrangement 107. In certain examples, each securement arrangement 107 includes a hook. In certain examples, each securement arrangement 107 includes a latching shoulder. In certain examples, each securement arrangement 107 includes rails extending outwardly from opposite sides of a ramp.

In certain examples, the adapter block assembly 100 defines recesses, channels, or other such features that provide clearance and/or alignment with the retention structure to which the adapter block assembly 100 is to be mounted. For example, the second non-port surface 106 defines a channel 106A that extends across the second non-port side 106 between the two port sides 101, 102. In certain examples, the channel 106A accommodates a raised portion of the retention structure. In an example, the channel 106A aligns with the raised portion to properly position the adapter block assembly 100 at the retention structure.

Referring to FIG. 3, the adapter block assembly 100 includes a first housing piece 110A that mates with a second housing piece 110B. Each housing piece 110A, 110B defines one of the port sides 101, 102. In certain examples, one or more adapters 130 are disposed between the first and second housing pieces 110A, 110B. Each adapter

130 includes the alignment structures that hold the plug connectors at the ports 108. In some examples, the first housing piece 110A is identical to the second housing piece 110B. In other examples, however, the first and second housing pieces 110A, 110B can be distinct from each other.

5                   FIGS. 4 and 5 illustrate an example housing piece 110 that is suitable for use as the first housing piece 110A and/or the second housing piece 110B. The housing piece 110 extends along the length of the adapter block 100 between the first and second sides 103, 104. The housing piece 110 includes a first surface 111 that defines one of the port sides 101, 102. The first surface 111 extends between opposite ends 112 of the  
10 housing piece 110. The ends 112 of two housing pieces 110 cooperate to form one of the adapter block assembly ends 103, 104 (see FIG. 1). One or more apertures 113 are defined in the first surface 111 to provide access to the ports. In some examples, each aperture 113 provides access to one port 108. In other examples, however, each aperture 113 can provide access to multiple ports 108. In other examples, the first surface 111  
15 defines a single aperture 113 that provides access to all ports 108 at the respective port side 101, 102.

The housing piece 110 includes retention walls 114 that extend between the first and second ends 112 and away from the first surface 111. The retention walls 114 extend from opposite sides of the first surface 111 so that the retention walls 114  
20 cooperate with the ends 112 and the first surface 111 to define an interior cavity 116. When the first and second housing pieces 110A, 110B are held together, the respective interior cavities 116 cooperate to define an interior in which one or more adapters 130 can be disposed as will be discussed in more detail herein.

A retention arrangement 120 (FIG. 2) holds together the first and second  
25 housing pieces 110. In certain examples, the retention arrangement 120 is disposed along the seam 121 (FIG. 2) between the two housing pieces 110A, 110B. In certain implementations, the retention arrangement 120 includes a first portion that is disposed at the first housing piece 110A and a second portion that is disposed at the second housing piece 110B. In certain examples, the retention arrangement 120 includes multiple  
30 retaining features that are disposed at each housing piece 110. The retaining features mate together to hold the housing pieces 110A, 110B together.

In some implementations, the first portion of the retention arrangement 120 includes a latch arm 122 and the second portion of the retention arrangement 120 defines a recess 123 in which the latch arm 122 is received. In other implementations, the first

portion of the retention arrangement 120 includes a recess 123 and the second portion of the retention arrangement 120 defines a latch arm 122 sized to be received in the recess 123. In still other implementations, each portion of the retention arrangement 120 includes both a latch arm 122 and a recess 123. The recess 123 of each portion of the retention arrangement 120 is sized and shaped to receive the latch arm 122 of the other portion. In certain examples, each portion of the retention arrangement 120 includes multiple latch arms 122 and multiple recesses 123.

In certain examples, each latch arm 122 includes engagement shoulders 125 disposed at a distal end of a flexible beam 124 so that the engagement shoulders 125 are cantilevered off the retention wall 114. In an example, a distal end of the latch arm 122 defines a ramp 126. In certain examples, each recess 123 defines engagement shoulders 127 that align with and abut engagement shoulders 125 of the latch arm 122 when the latch arm 122 is received at the recess 123 (see FIG. 7). In certain examples, one or more ramped surfaces 128A lead to each recess 123 so that the ramp 126 of the latch arm 122 cams over the ramped surface 128A until the engagement shoulders 125 of the latch arm 122 snap into the recess behind the engagement shoulders 127 of the recess 123.

In an example, another ramped surface 128B may be provided at the opposite end of the recess 123 from the ramped surface(s) 128A. The ramped surface 128B accommodates the ramp 126 of the latch arm 122. In certain examples, the ramped surface 128B facilitates separation of the first and second portions of the retention arrangement 120. For example, a tool can be wedge between the ramp 126 and the ramped surface 128B to pry the latch arm 122 out of the recess 123.

In certain implementations, the housing pieces 110A, 110B only fit together in a specific rotational orientation of each housing piece 110A, 110B. Accordingly, each housing piece 110 may include alignment structures 129 that are disposed on one non-port side 105, 106 and not on the other non-port side 106, 105. In the example shown in FIG. 5, one end of the first non-port side 105 of the housing piece 110 includes a protrusion 129A and the opposite end of the first non-port side 105 defines a notch 129B sized to receive the protrusion 129A. The second non-port side 106 does not include either the protrusion 129A or the notch 129B. In certain examples, the protrusion 129A fits in the notch 129B without forming an attachment thereto (in contrast to latch arms 122 and recesses 123).

In the example shown, each housing piece 110 includes part 107A, 107B of the securement arrangement 107 at each end 112. The securement arrangement parts

107A, 107B of adjoining ends 112 cooperate to define a single securement arrangement 107 when two housing pieces 110A, 110B are joined together. In other examples, however, each housing piece 110 can include a full securement part 107 at one end 112 and no securement part at the other end 112. In still other examples, one of the housing  
5 pieces 110A, 110B can include both securement arrangements 107 and the other housing piece 110A, 110B can be devoid of securement arrangements 107 or parts thereof.

Each housing piece 110 includes structure that retains the adapter(s) 130 within the interior formed by the combined cavities 116 of the housing pieces 110. In certain examples, each adapter block assembly 100 holds multiple adapters 130. In some  
10 such implementations, each housing piece 110 includes dividing walls 117 that separate the adapters 130. In certain examples, each dividing wall can include features that aid in retaining the adapter 130 at a specific location within the housing piece 110 as will be discussed in more detail herein.

FIG. 6 illustrates an example adapter 130 suitable for use in the adapter  
15 block assembly 100. In the example shown, the adapter 130 is a multi-fiber adapter that is configured to receive a multi-fiber plug connector (e.g., an MPO connector) at each port 134. In other examples, however, the adapter 130 can be configured to receive any desired type of plug connector (e.g., a single fiber connector, an electrical connector, etc.) at each port 134.

20 The adapter 130 includes opposing major surfaces 131 extending between opposite end surfaces 132. Opposite port surfaces 133 extend between the opposite major surfaces 131 and between the opposite end surfaces 132. Each port surface 133 defines one or more adapter ports 134 leading to alignment structure for a plug connector received at the port 134. In certain examples, each adapter port 134 defines a keyway 135  
25 configured to align with a key disposed on the plug connector to indicate a proper rotational orientation of the plug connector at the port 134. In various examples, the keyway orientation can be configured as either Method A (i.e., key-up/key-down) or Method B (key-up/key-up). In certain examples, retention structure (e.g., latch arms, inward-facing shoulders, bayonet lugs, etc.) for engaging the plug connector is disposed at  
30 each port 134.

In some implementations, each adapter 130 is configured to receive a single plug connector at each port side 133. In other examples, however, each adapter 130 is configured to receive multiple plug connectors at each port side 133. In the example shown, each adapter 130 is configured to receive two plug connectors at each port side

133. In certain examples, the adapter 130 is elongated along a length between the opposite ends 132 and the ports 134 of one port side 133 are disposed in a row along the elongated length.

5 In the example shown, the adapter 130 defines a recessed band 137 extending circumferentially or partially circumferentially around the major side(s) 131 and ends 132 of the adapter 130. In certain examples, a rib 138 can be disposed in the recessed band 137.

10 In certain examples, each adapter 130 fits within the interior of the adapter block assembly 100 so that the ports 134 of the adapter 130 align with the port holes 113 defined in the first side 111 of each housing piece 110. In some examples, multiple adapters 130 are disposed within the adapter block assembly interior in a row. In certain examples, dividing walls separate the adapters 130 from each other. In certain examples, each adapter 130 includes a first engagement feature that interacts with a second engagement feature of the dividing wall 117.

15 In the example shown in FIG. 6, the adapter 130 includes a protrusion 136 that functions as an engagement feature of the adapter 130. In other examples, however, the engagement feature could be a recess, a latch, a ramp, etc. In the example housing piece 110 shown in FIGS. 4 and 5, each housing piece 110 includes a dividing wall section 117 that is shaped to cooperate with a dividing wall section 117 of the other housing piece 110 to form the dividing wall 117. In certain examples, each dividing wall section 117 defines a notch 118 that cooperates with a notch 118 of the corresponding dividing wall section 117 of the other housing piece 110 to provide an aperture in which the protrusion 136 is captured (see FIG. 7). Accordingly, the notched dividing wall sections 117 cooperate to hold the adapter 130 in a particular position within the housing pieces 110.

20 In certain implementations, each housing piece 110 also can include positioning structures (e.g., ribs 119) that aid in properly positioning the adapter 130 within the housing piece 110. In certain examples, the ribs 119 hold the adapter 130 away from the retention wall 114 enough to enable sufficient flexing of the retention wall 114 relative to the adapter to secure the two portions of the retention arrangement 120 together.

25 Referring to FIGS. 8-15, a fixture 140 can be provided to aid in assembling the adapter block assembly 100. The fixture 140 holds the components in place during assembly. The fixture 140 also aids in rotationally aligning the components.

30 An example fixture 140 suitable for use in assembling the adapter block assembly 100 disclosed herein is shown in FIGS. 8 and 9. The fixture 140 includes a base

141 elongated along a length between a first end and a second end. One or more alignment members 142 are disposed in a row along the base 141. Each alignment member 142 extends upwardly from the base 141. Each alignment member 142 is sized to fit within a port 134 of an adapter 130. In certain examples, each alignment member 142 includes a key 143 that is sized and shaped to fit within the keyway 135 defined at the adapter port 134.

A first alignment guide 144 extends upwardly from the base 141 at the first end and a second alignment guide 144 extends upwardly from the base 141 at the second end. Each alignment guide 144 defines a channel or other guide 145 sized and shaped to accommodate a securement arrangement 107 of the adapter block assembly 100. Each guide channel 145 is open at a top of each alignment guide 144.

First and second sides 146, 147 of the fixture 141 extend along the base 141 between the first and second ends. The keys 143 of the alignment members 142 extend towards the first side 146. The opposite side of the alignment members 142 from the keys 143 faces the second side 147. In certain examples, indicia 148A are provided at the first side 146 and not at the second side 147 to distinguish between the first and second sides 146, 147. In certain examples, a flange 148B or notch can be provided at the first side 146 and not at the second side 147 to distinguish between the first and second sides 146, 147.

As shown in FIGS. 8 and 9, a user begins to assemble the adapter block 100 by inserting a first housing piece 110, 110A onto the fixture 140. The housing piece 110, 110A is oriented so that the first surface 111 is facing towards the base 141 of the fixture 140. A first portion of the retention arrangement faces away from the fixture 140. During insertion, the securement arrangement parts 107A at opposite ends of the housing piece 110A ride along the guide channels 145 defined in the first and second alignment guides 144 of the fixture 140. The alignment members 142 of the fixture 140 pass through openings 113 defined by the first surface 111 of the housing piece 110, 110A. In certain examples, the housing piece 110, 110A is inserted until the housing piece 110, 110A bottoms out on the base 141.

In certain examples, the user can use the alignment structures 129 to properly rotationally orient the housing piece 110, 110A relative to the fixture 140. In certain examples, the housing piece 110 can be rotationally oriented relative to the fixture 140 so that the alignment structures 129A, 129B of the housing 110 face the alignment flange 148B of the fixture 140. In certain examples, the housing piece 110 can be

rotationally oriented relative to the fixture 140 so that the alignment structures 129A, 129B of the housing 110 face the indicia 146A of the fixture 140.

As shown in FIG. 10, one or more adapters 130 are inserted into the cavities defined by the first housing piece 110, 110A. As the adapters 130 are slid onto  
5 the fixture 140, the alignment members 142 of the fixture 140 slide into the ports 134 at one port side 133 of the adapter 130. The keys 143 of the alignment members 142 slide along the keyways 135 of the ports 134. Accordingly, the keys 143 of the alignment members 142 inhibit insertion of an adapter 130 that is not properly rotationally oriented to align the keys 143 and the keyways 135.

10 The keys 143 of the fixture 140 ensure that the ports 134 of the adapters 130 are rotationally oriented in a predetermined manner relative to the adapter block assembly 100. In some examples, the fixture 140 includes keys 143 that all face the first side 146 of the fixture 140. Such a fixture 140 ensures the formation of an adapter block assembly 100 having all ports 108 with a common rotational orientation (i.e., all plug  
15 connectors received at the ports 108 will have a common rotational orientation). In other examples, however, the keys 143 can be arranged on the alignment members 142 to rotationally orient each adapter 130 in any desired position. For example, the keys 143 can be disposed at alternating sides of the fixture 140 to provide ports having alternating rotational alignment (i.e., a row of ports 134 having keyways 135 on alternate sides along  
20 the row).

In certain examples, the indicia 148A and/or flange 148B may aid a user in properly orienting the adapter 130 relative to the fixture 140 and first housing piece 110, 110A. In the example shown, the user can align the adapter 130 so that the keyway 135 faces away from the indicia 148A and flange 148B.

25 In some examples, the adapters 130 are inserted until the protrusions 136 abut the notches 118 of the dividing wall sections 117. In other examples, the adapters 130 are inserted until one of the port sides 133 bottoms out against the first side 111 of the housing piece 110, 110A.

As shown in FIG. 11, a second housing piece 110, 110B is mounted to the  
30 fixture 140 over the adapters 130 so that the adapters 130 are sandwiched between the first and second housing pieces 110A, 110B. The housing piece 110, 110B is oriented so that the first surface 111 is facing away from the base 141 of the fixture 140. The second portion of the retention arrangement 120 faces the fixture 140. During insertion, the securement arrangement parts 107B at opposite ends of the housing piece 110B ride along

the guide channels 145 defined in the first and second alignment guides 144 of the fixture 140.

As the second housing piece 110, 110B is mounted onto the fixture 140, the second portion of the retention arrangement 120 moves towards and then mates with the first portion of the retention arrangement 120. In certain examples, latch arms 122 of each portion cam over corresponding ramped surfaces 128A and then snap into corresponding recesses 123 (see FIG. 12). In certain examples, the protrusion 129A of the second housing piece 110, 110B fits into the notch 129B of the first housing piece 110, 110A. The protrusion 129A of the first housing piece 110, 110A fits into the notch 129B of the second housing piece 110, 110B.

As shown in FIG. 12, the fixture 140 holds the assembled adapter block assembly 100 when the second housing piece 110B is attached to the first housing piece 110A. The indicia 148A, 148B of the fixture 140 identify a rotational orientation of the adapter block assembly 100. For example, the indicia 148A, 148B indicate which non-port side 105, 106 of the adapter block assembly 100 the keyways 135 of the adapter ports 134 face.

As shown in FIGS. 13 and 14, the fixture 140 can be utilized to attach labels to the adapter block assembly 100. For example, the fixture 140 can be laid on the non-port side that does not include the indicia 148A, 148B. A user can apply one or more port labels 160 to this non-port side 105 of the adapter block assembly 100. In certain implementations, a sidewall 149 of the fixture 140 is sufficiently short to provide access to a majority of the non-port side 105. In an example, the port labels are adhesively fixed to the non-port side 105.

In certain examples, the port labels 160 extend over at least part of the seam 121 between the first and second housing pieces 110A, 110B. In certain examples, the port labels 160 extend over at least part of the retention arrangement 120. In the example shown, the port labels 160 fully cover the latch arms 122 and recesses 123. Accordingly, the port labels 160 can provide anti-tamper functionality (by inhibiting manual separation of the housing pieces or showing damage to alert a user to tampering by others).

As shown in FIG. 14, the fixture 140 can be flipped over 180° so that the indicia 148A, 148B face the surface on which the fixture 140 is seated. A block label 165 can be added to the second non-port side 106 of the adapter block assembly 100. In certain examples, the block label 165 extends over at least part of the seam 121 between the first and second housing pieces 110A, 110B. In certain examples, the block label 165

extends over at least part of the retention arrangement 120. In the example shown, the block label 165 fully covers two of the latch arms 122 and recesses 123 of the retention arrangement 120.

5 As shown in FIG. 15, the adapter block assembly 100 can be removed from the fixture 140. In certain examples, the adapter block assembly 100 is removed by sliding the adapter block assembly 100 away from the base 141 so that the securement arrangements 107 slide along the guide channels 145 and through the open tops of the guide channels 145.

10 Having described the preferred aspects and implementations of the present disclosure, modifications and equivalents of the disclosed concepts may readily occur to one skilled in the art. However, it is intended that such modifications and equivalents be included within the scope of the claims which are appended hereto.

**What is claimed is:**

1. An adapter block assembly having a length extending between a first end and a second end, the adapter block assembly having a first port side and an opposite second port side that each extend along the length between the first and second ends, the adapter block assembly comprising:
  - a first housing piece that extends along the length between the first and second ends, the first housing piece defining the first port side, the first housing piece also including a first portion of a retention arrangement;
  - a second housing piece that extends along the length between the first and second ends, the second housing piece defining the second port side, the second housing piece also including a second portion of a retention arrangement, the second portion being configured to mate with the first portion to hold the first and second housing pieces together, wherein the first and second cavities cooperate to define an interior when the first and second housing pieces are held together; and
  - an adapter disposed within the interior, the adapter including a body extending between a first port and a second port, wherein an intermediate portion of the body engages at least one of the first and second housing pieces.
2. The adapter block assembly of claim 1, wherein the adapter is one of a plurality of adapters that fit within the interior.
3. The adapter block assembly of claim 2, wherein the adapters fit within the interior in a row.
4. The adapter block assembly of any preceding claim, wherein the adapter is configured to receive and align two multi-fiber connectors.
5. The adapter block assembly of claim 4, wherein the adapter is a duplex adapter configured to receive and align two pairs of multi-fiber connectors.
6. The adapter block assembly of any preceding claim, and preferably claim 2, wherein dividing walls are disposed within the interior between the adapters, each adapter

being engaged to at least one of the dividing walls to hold the adapter in a particular position within the interior.

7. The adapter block assembly of claim 6, wherein the dividing walls each define a notch; and wherein each adapter includes a protrusion sized to fit in the notch.
8. The adapter block assembly of claim 7, wherein each dividing wall includes a first portion carried by the first housing piece and a second portion carried by the second housing piece, wherein the first and second portions of the dividing walls cooperate to define the respective notch when the first and second housing pieces are held together.
9. The adapter block assembly of any preceding claim, wherein the first portion of the retention arrangement includes a latch arm and the second portion of the retention arrangement includes a latch receptacle sized to receive the latch arm.
10. The adapter block assembly of any preceding claim, and in particular claim 9, wherein the first portion of the retention arrangement includes a plurality of latch arms and the second portion of the retention arrangement includes a plurality of latch receptacles, each latch receptacle sized to receive a corresponding one of the latch arms.
11. The adapter block assembly of any preceding claim, wherein the first portion of the retention arrangement includes a first latch arm and a first latch receptacle and the second portion of the retention arrangement includes a second latch arm and a second latch receptacle sized to receive the first latch arm, wherein the first latch receptacle is sized to receive the second latch arm.
12. The adapter block assembly of claim 11, wherein each portion of the retention arrangement includes a plurality of latch arms and a plurality of latch receptacles.
13. The adapter block assembly of any preceding claim, wherein the first housing piece is identical to the second housing piece.
14. The adapter block assembly of any preceding claim, wherein the first housing piece includes a first retention wall that extends around the first port side to define a first

cavity and the second housing piece includes a second retention wall that extends around the second port side to define a second cavity that aligns with the first cavity to form the interior when the first and second housing pieces are joined together, wherein the first and second retention walls cooperate to define first and second non-port sides of the adapter block assembly when the second housing piece is held to the first housing piece, at least one of the non-port sides defining a recessed area at which a label can be disposed.

15. The adapter block assembly of any preceding claim, and in particular claim 14, further comprising a label attached to the first non-port side to cover at least part of the first and second portions of the retention arrangement.

16. The adapter block assembly of any preceding claim, further comprising a first securement arrangement disposed at the first end of the adapter block assembly and a second securement arrangement disposed at the second end of the adapter block assembly, wherein each of the securement arrangements includes a first part disposed at the first housing piece and a second part disposed at the second housing pieces, the first part cooperating with the second part to form the respective securement arrangement when the first housing piece is held to the second housing piece.

17. The adapter block assembly of claim 16, wherein the first securement arrangement is fully formed by the first housing piece and the second securement arrangement is fully formed by the second housing piece, wherein each securement arrangement includes a latching hook.

18. The adapter block assembly of any preceding claim, and in particular any of claim 12, wherein the first housing piece includes alignment structures disposed on one of the non-port sides and not on the other non-port side.

19. A fixture for use in assembling an adapter block assembly, the fixture comprising:  
a body including a base that is elongated along a length between a first end and a second end; and

a plurality of alignment members disposed in a row along the base and extending upwardly from the base, each alignment member being sized to fit within a port of an adapter.

20. The fixture of claim 19, further comprising:  
a first alignment guide extending upwardly from the base at the first end; and  
a second alignment guide extending upwardly from the base at the second end;.
21. The fixture of any of claims 19-20, wherein each alignment member includes a key member sized and shaped to fit within a keyway defined by a respective port of an adapter.
22. The fixture of any of claims 19-21, further comprising the adapter block assembly of any of claims 1-17 mounted thereto.
23. The fixture of any of claims 19-21, further comprising a first housing piece mounted thereto.
24. The fixture of claim 23, further comprising an adapter mounted over the first housing piece so that one of the alignment members extends into a port defined by the adapter.
25. The fixture of any of claims 19-24, and in particular to claim 22, wherein sides of the fixture that extend between the first and second ends are sufficiently low to the base to enable labels to be added to the adapter block assembly without removing the adapter block assembly from the fixture.
26. The fixture of any of claims 19-25, and in particular to claim 22, wherein the fixture includes indicia that indicate a rotational orientation of the adapter block assembly.
27. A method of assembling of adapter block assembly, the method comprising:  
mounting a first housing piece onto a fixture, the first housing piece having a first port side facing a base of the fixture, the fixture including an alignment member that extends upwardly through an aperture defined in the first port side of the first housing piece.

28. The method of claim 27, further comprising mounting an adapter to the fixture over the first housing piece, the adapter defining a port, the adapter being mounted so that the alignment member extends into the port.

29. The method of any of claims 27 and 28, further comprising:  
mounting a second housing piece over the adapter so that the adapter is disposed within a cavity defined by the first and second housing pieces; and  
securing the second housing piece to the first housing piece to form an adapter block assembly.

30. The method of any of claims 27-29, wherein the alignment member includes a key that fits with a keyway defined at the port to rotationally orient the adapter relative to the fixture.

31. The method of any of claims 27-30, and in particular to claim 28, further comprising applying a label to a first non-port side of the adapter block assembly without removing the adapter block assembly from the fixture.

32. The method of claim 31, further comprising rotating the fixture and the adapter block assembly to lay an opposite second non-port side on a surface prior to applying the label to the first non-port side, wherein the fixture is rotated based on indicia identifying the first non-port side.

33. The method of claim 32, further comprising:  
rotating the fixture and the adapter block assembly to lay the first non-port side on the surface; and  
applying a second label to the second non-port side.

FIG. 1

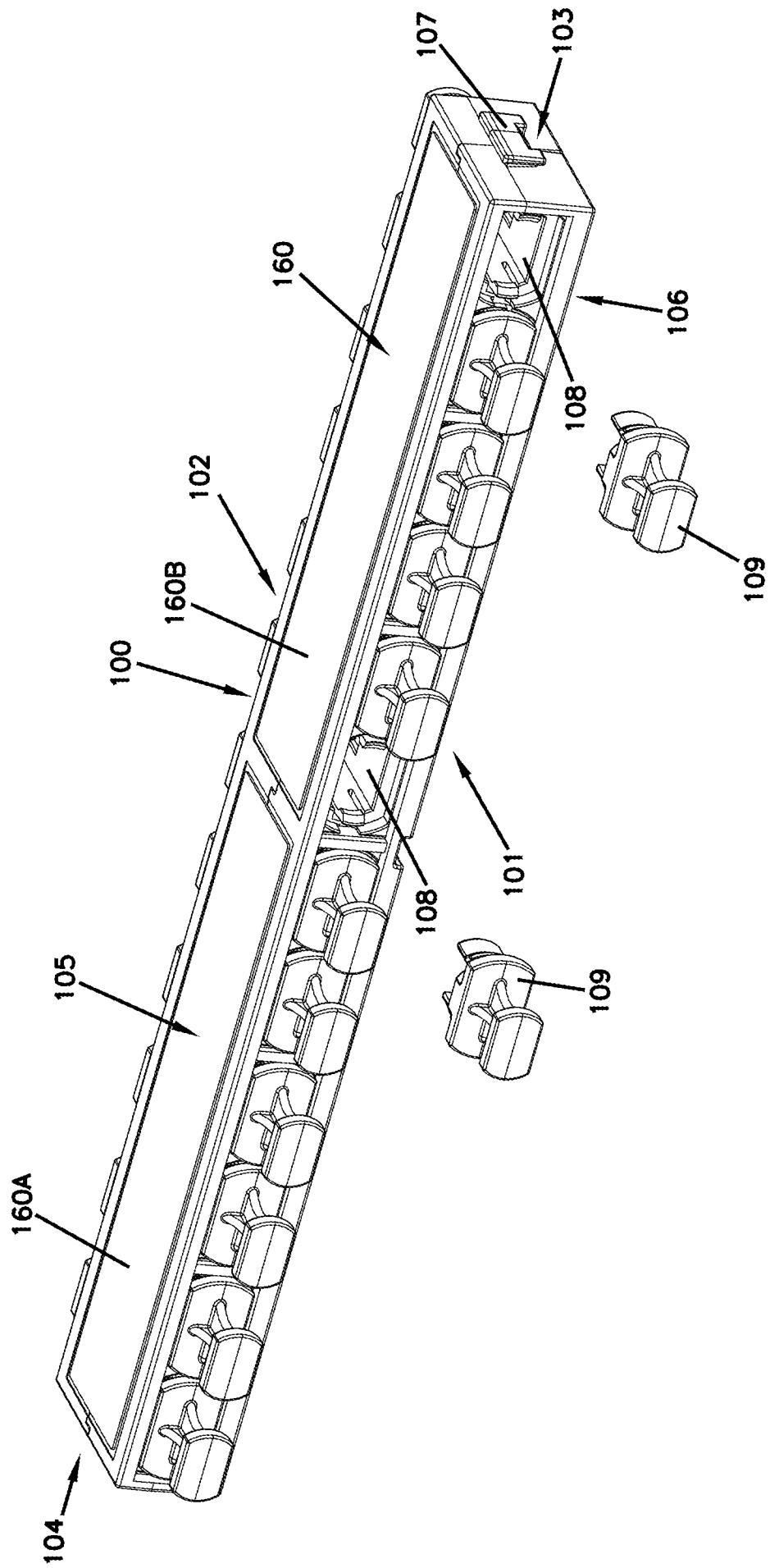

FIG. 2

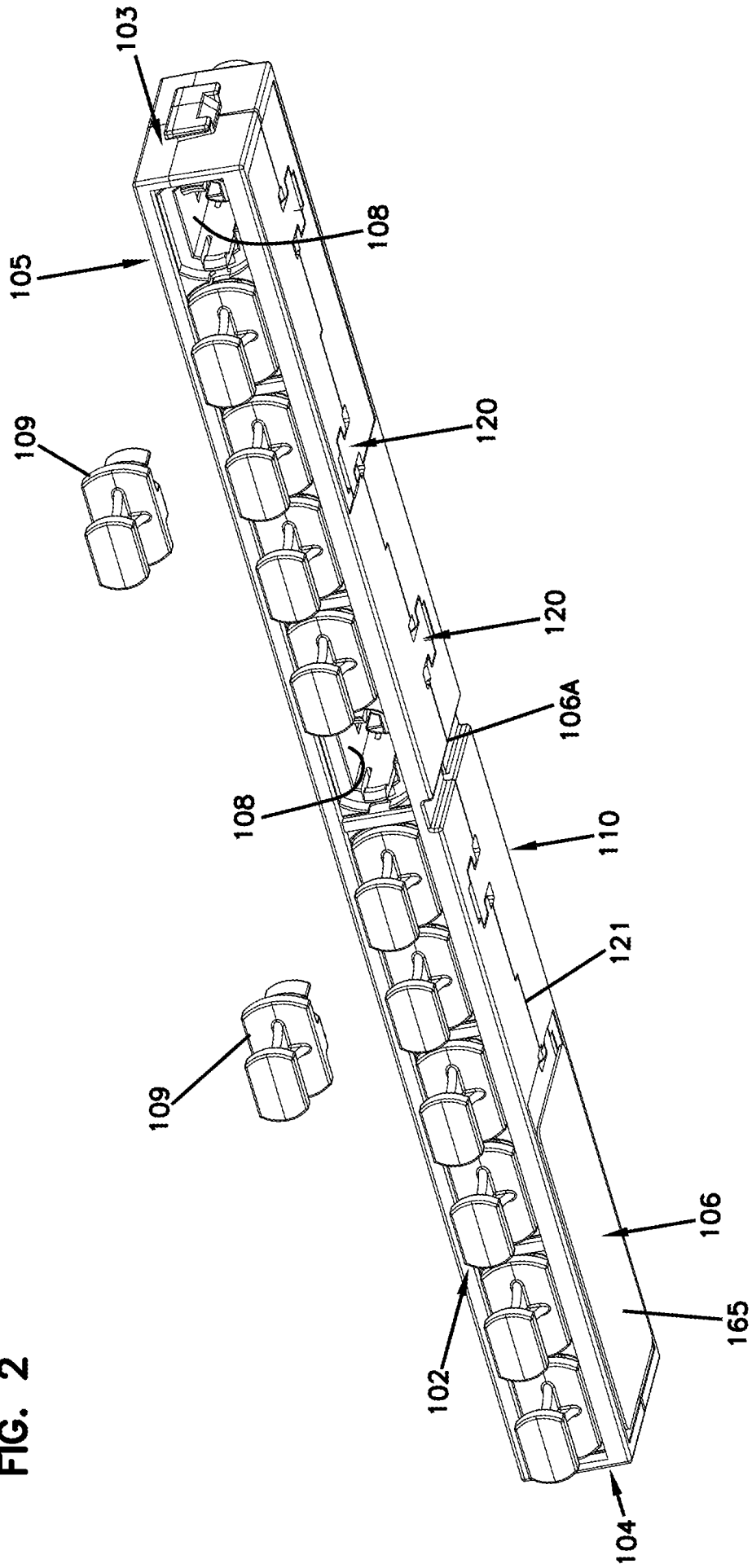

FIG. 3

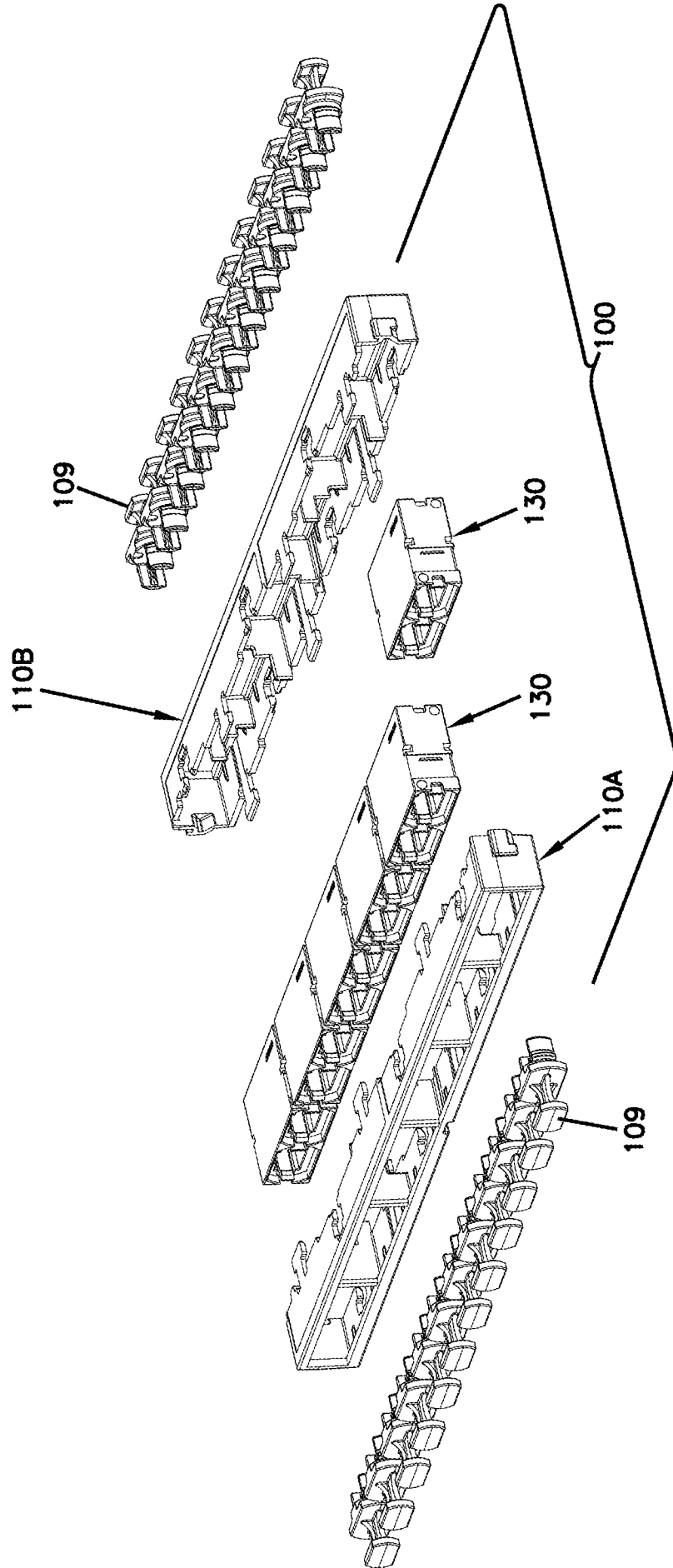



FIG. 5

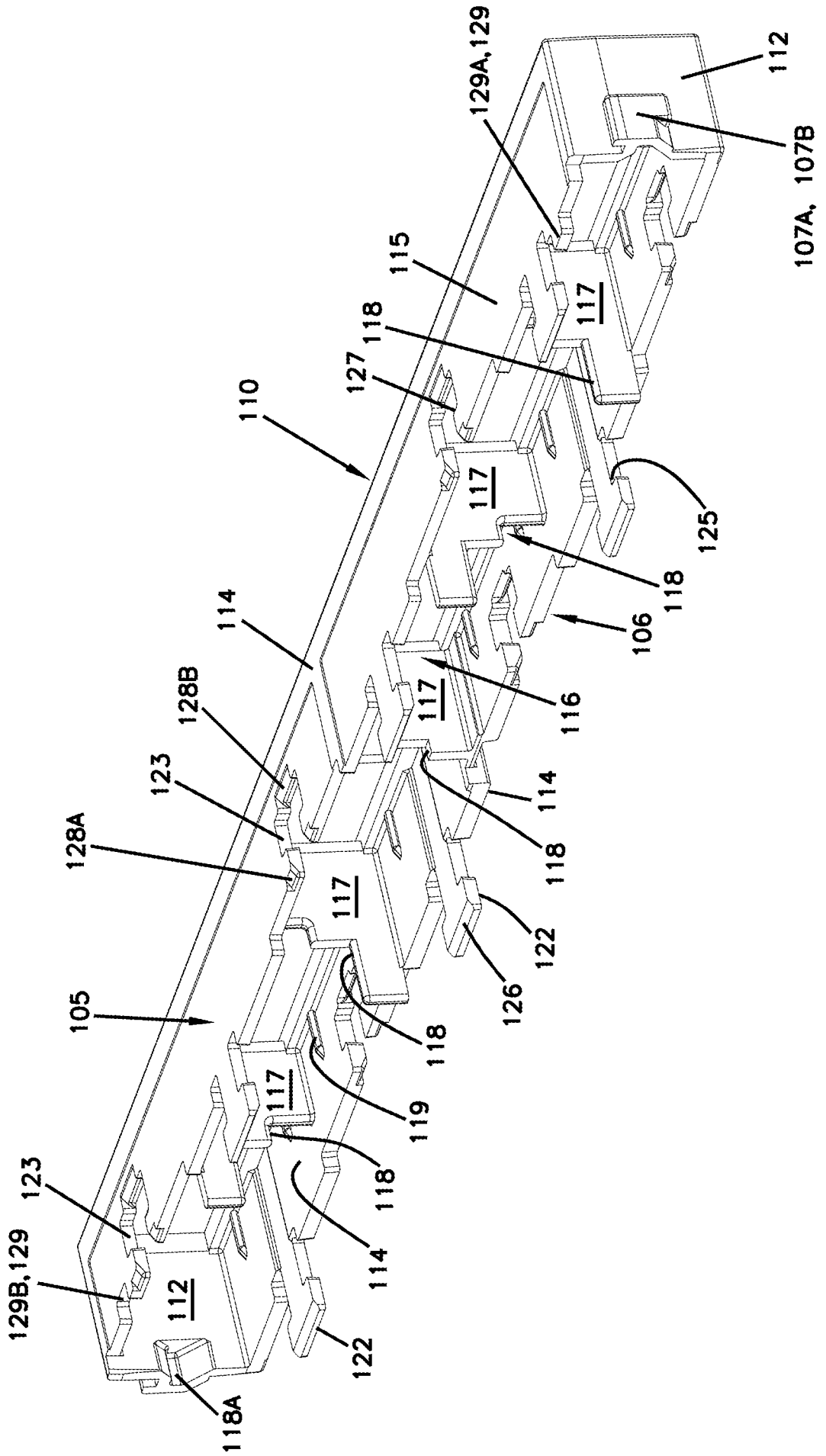

FIG. 6

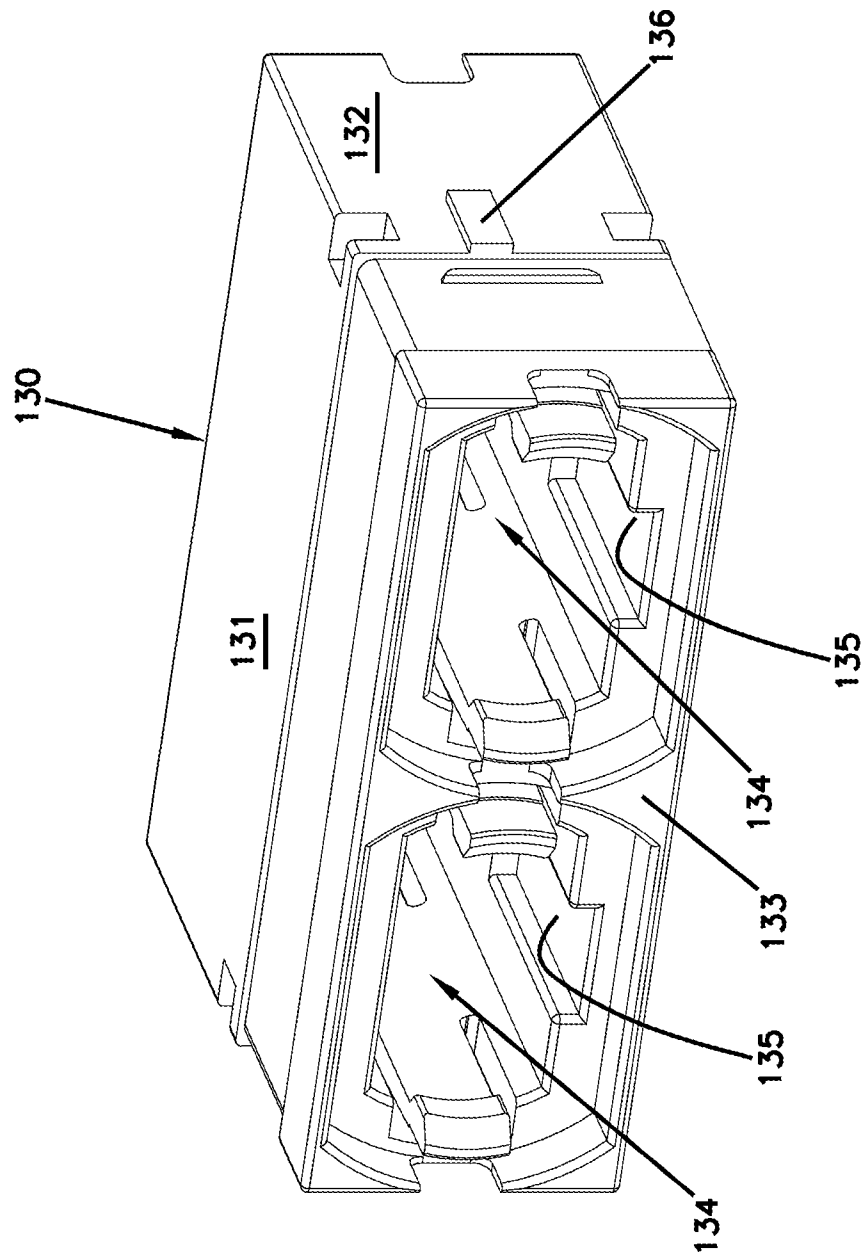

FIG. 7

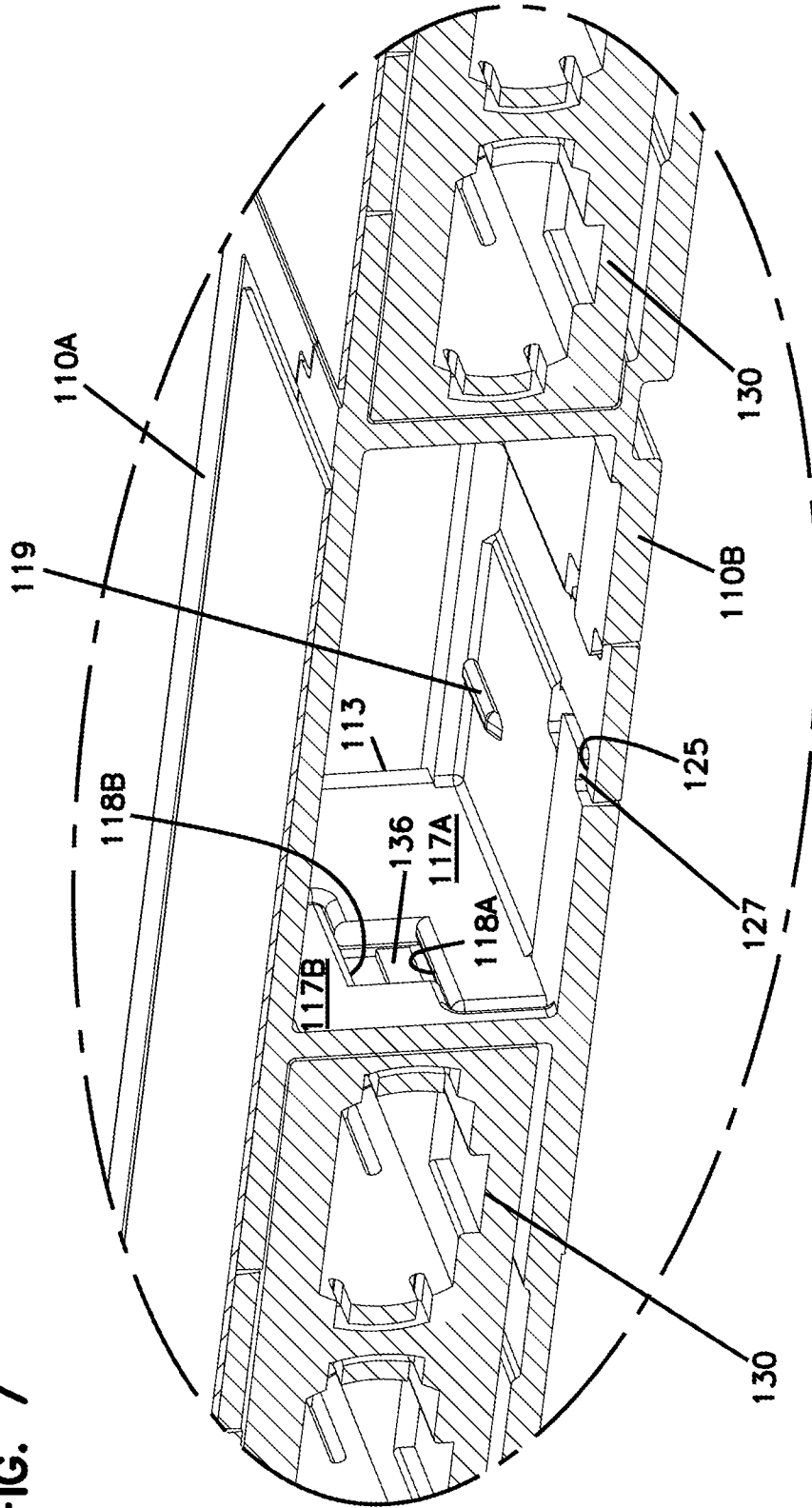

FIG. 8

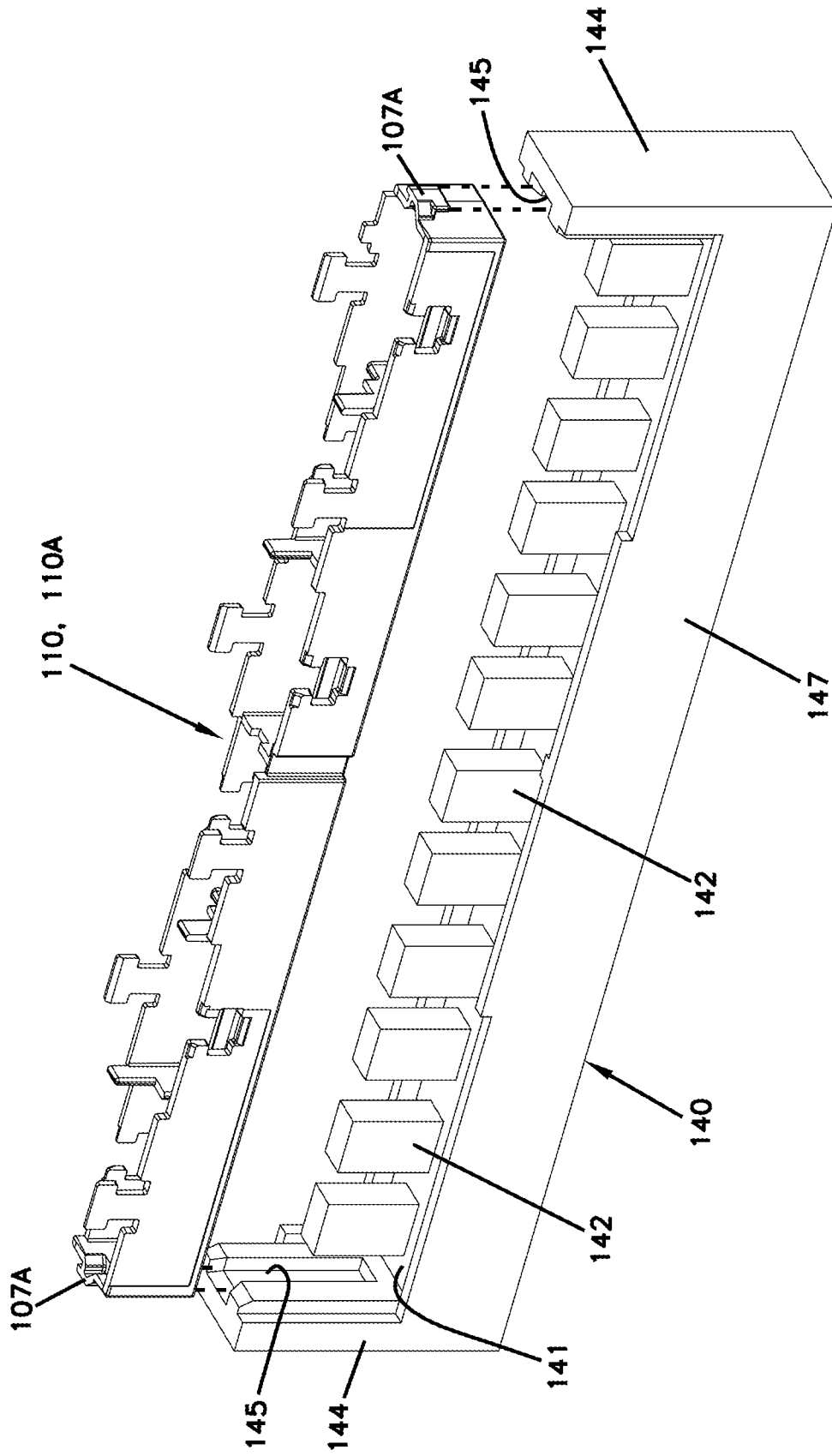
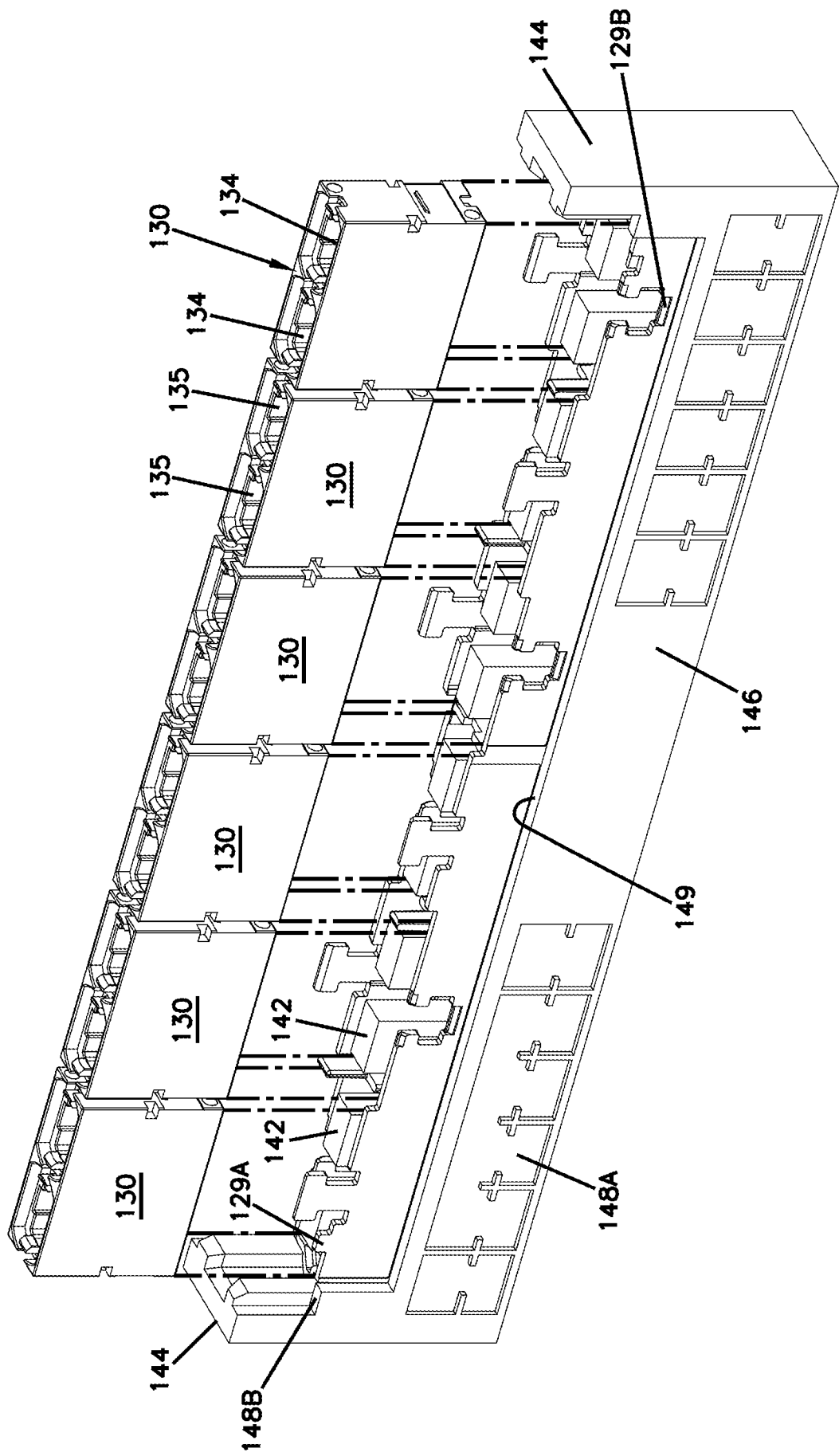



FIG. 10



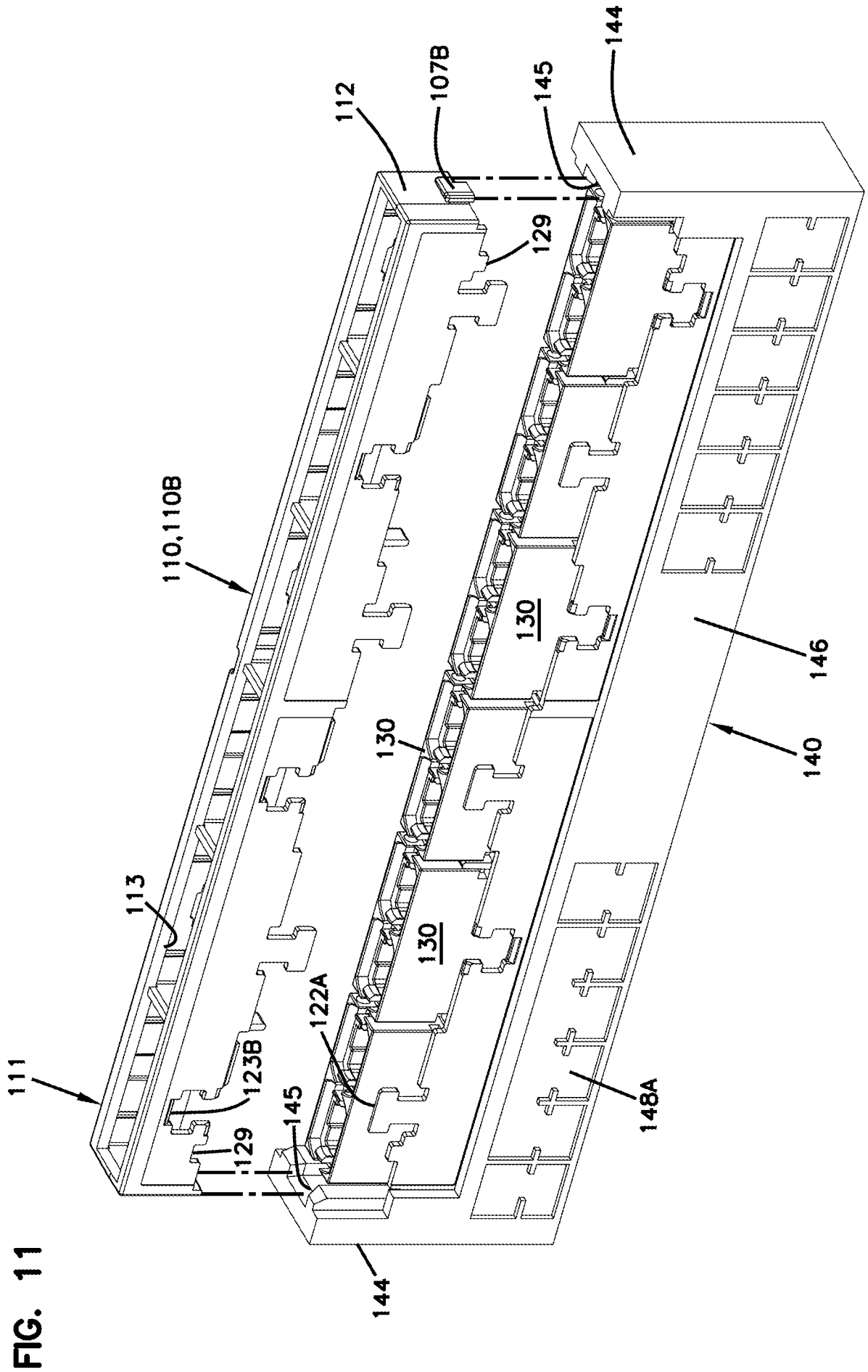

FIG. 12

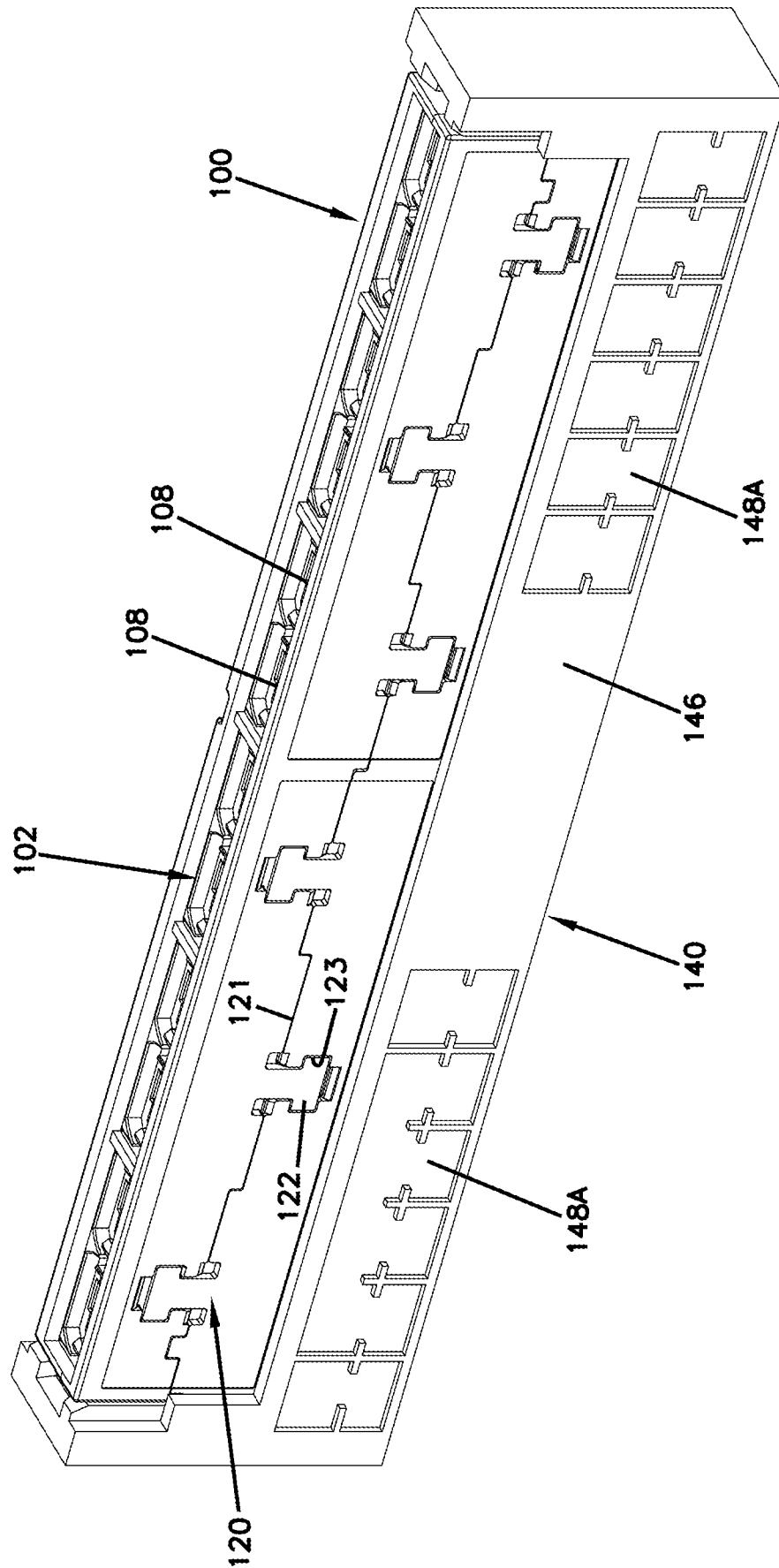

FIG. 13

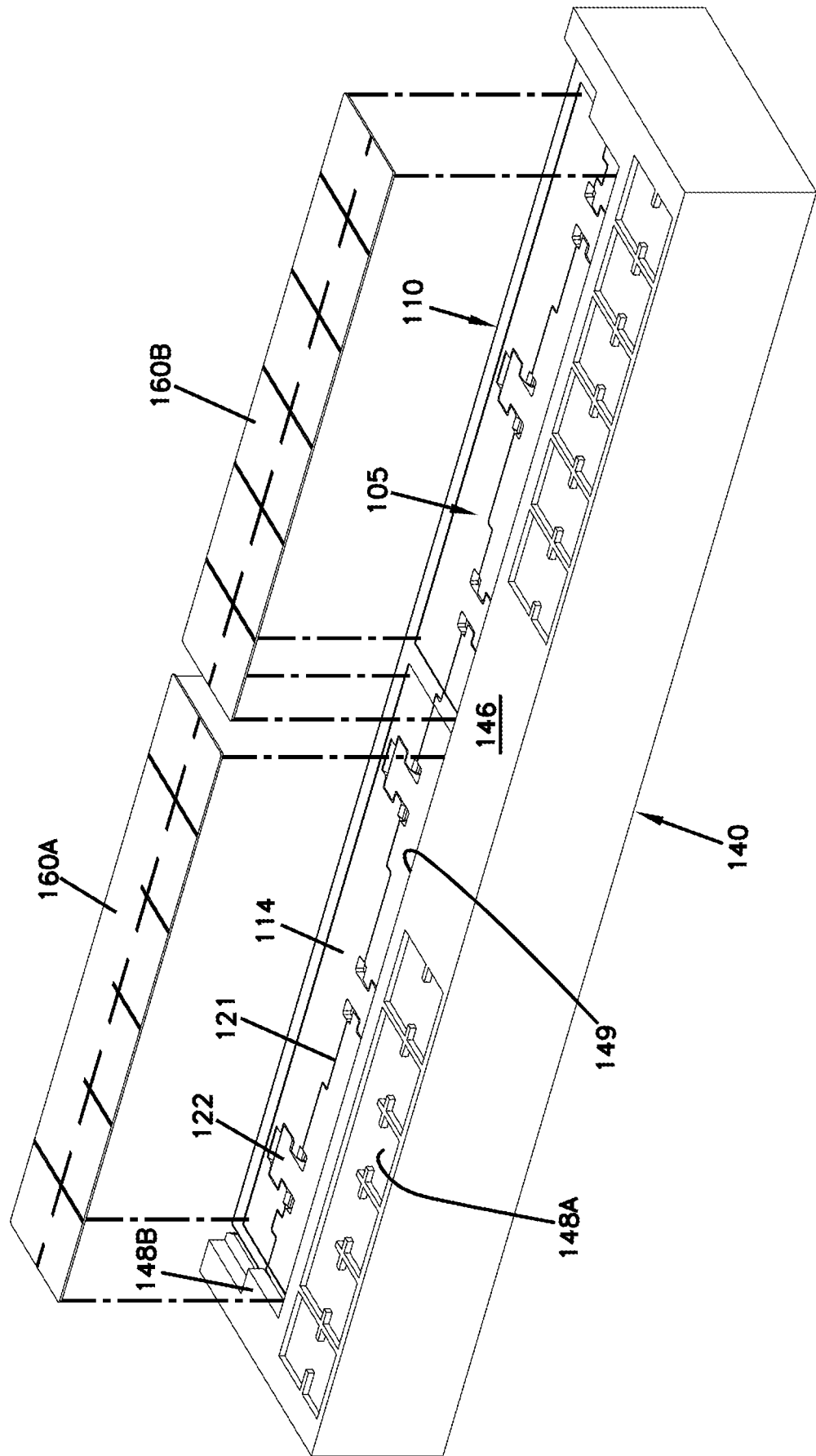

FIG. 14

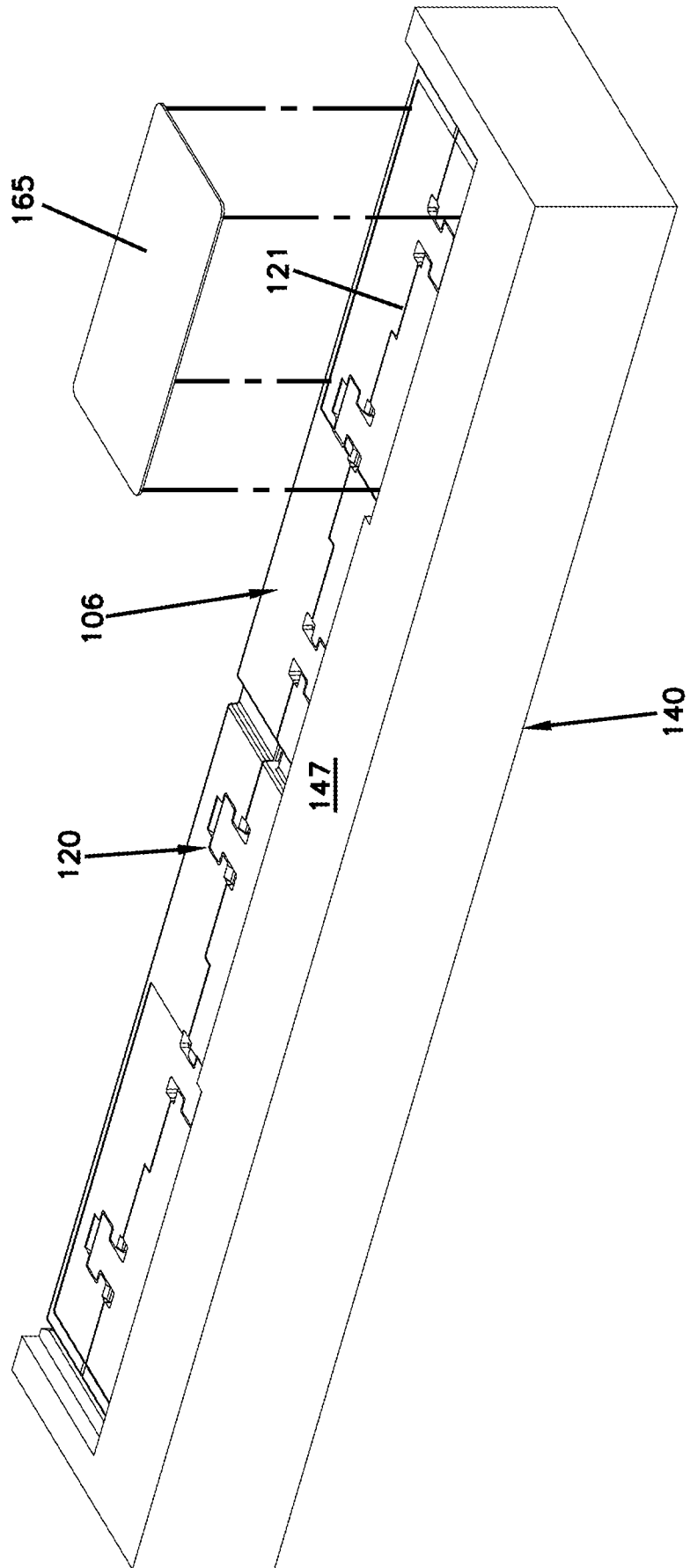
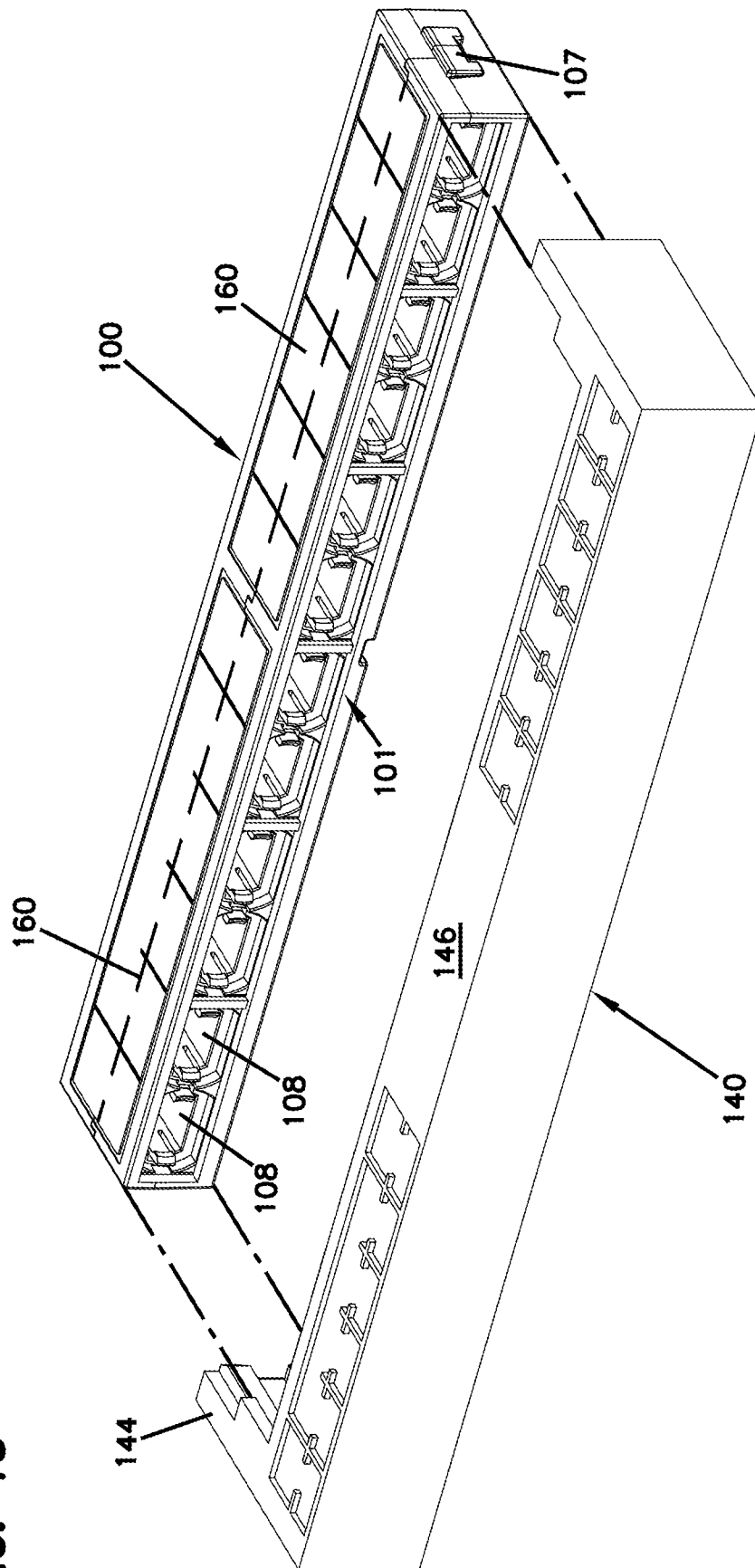

FIG. 15



**A. CLASSIFICATION OF SUBJECT MATTER****G02B 6/38(2006.01)i**

According to International Patent Classification (IPC) or to both national classification and IPC

**B. FIELDS SEARCHED**Minimum documentation searched (classification system followed by classification symbols)  
G02B 6/38; H01R 13/648; G02B 6/42; G02B 6/00; G02B 6/36; H01R 13/627Documentation searched other than minimum documentation to the extent that such documents are included in the fields searched  
Korean utility models and applications for utility models  
Japanese utility models and applications for utility modelsElectronic data base consulted during the international search (name of data base and, where practicable, search terms used)  
eKOMPASS(KIPO internal) & Keywords: adapter, first and second housing pieces, retention arrangement, fixture, alignment**C. DOCUMENTS CONSIDERED TO BE RELEVANT**

Category*	Citation of document, with indication, where appropriate, of the relevant passages	Relevant to claim No.
Y	US 2016-0187594 A1 (COMMSCOPE TECHNOLOGIES LLC. et al.) 30 June 2016 See paragraphs [0077], [0093], [0098] and figures 1, 6, 19-20.	1-5, 19-21, 27-29
Y	US 5688145 A (LIU) 18 November 1997 See column 4, lines 21-26 and figure 1.	1-5, 29
Y	US 2012-0020634 A1 (SMRHA et al.) 26 January 2012 See paragraph [0025] and figure 1.	19-21, 27-29
A	WO 2013-109469 A1 (ADC TELECOMMUNICATIONS, INC.) 25 July 2013 See claim 1 and figures 1-2.	1-5, 19-21, 27-29
A	EP 2922147 A1 (JAPAN AVIATION ELECTRONICS INDUSTRY LIMITED et al.) 23 September 2015 See claim 1 and figure 1.	1-5, 19-21, 27-29

 Further documents are listed in the continuation of Box C. See patent family annex.

\* Special categories of cited documents:

"A" document defining the general state of the art which is not considered to be of particular relevance

"E" earlier application or patent but published on or after the international filing date

"L" document which may throw doubts on priority claim(s) or which is cited to establish the publication date of another citation or other special reason (as specified)

"O" document referring to an oral disclosure, use, exhibition or other means

"P" document published prior to the international filing date but later than the priority date claimed

"T" later document published after the international filing date or priority date and not in conflict with the application but cited to understand the principle or theory underlying the invention

"X" document of particular relevance; the claimed invention cannot be considered novel or cannot be considered to involve an inventive step when the document is taken alone

"Y" document of particular relevance; the claimed invention cannot be considered to involve an inventive step when the document is combined with one or more other such documents, such combination being obvious to a person skilled in the art

"&amp;" document member of the same patent family

Date of the actual completion of the international search

10 January 2018 (10.01.2018)

Date of mailing of the international search report

**10 January 2018 (10.01.2018)**

Name and mailing address of the ISA/KR

International Application Division  
Korean Intellectual Property Office  
189 Cheongsa-ro, Seo-gu, Daejeon, 35208, Republic of Korea

Facsimile No. +82-42-481-8578

Authorized officer

Kim, Yeonkyung

Telephone No. +82-42-481-3325



**Box No. II Observations where certain claims were found unsearchable (Continuation of item 2 of first sheet)**

This international search report has not been established in respect of certain claims under Article 17(2)(a) for the following reasons:

1.  Claims Nos.:  
because they relate to subject matter not required to be searched by this Authority, namely:
  
2.  Claims Nos.: 7-8, 12, 17, 24, 32-33  
because they relate to parts of the international application that do not comply with the prescribed requirements to such an extent that no meaningful international search can be carried out, specifically:  
Claims 7-8, 12, 17, 24 and 32-33 are regarded to be unclear because the claims refer to multiple dependent claims which do not comply with PCT Rule 6.4(a).
  
3.  Claims Nos.: 6, 9-11, 13-16, 18, 22-23, 25-26, 30-31  
because they are dependent claims and are not drafted in accordance with the second and third sentences of Rule 6.4(a).

**Box No. III Observations where unity of invention is lacking (Continuation of item 3 of first sheet)**

This International Searching Authority found multiple inventions in this international application, as follows:

1.  As all required additional search fees were timely paid by the applicant, this international search report covers all searchable claims.
  
2.  As all searchable claims could be searched without effort justifying an additional fees, this Authority did not invite payment of any additional fees.
  
3.  As only some of the required additional search fees were timely paid by the applicant, this international search report covers only those claims for which fees were paid, specifically claims Nos.:
  
  
  
  
  
  
  
  
  
  
4.  No required additional search fees were timely paid by the applicant. Consequently, this international search report is restricted to the invention first mentioned in the claims; it is covered by claims Nos.:

**Remark on Protest**

- The additional search fees were accompanied by the applicant's protest and, where applicable, the payment of a protest fee.
- The additional search fees were accompanied by the applicant's protest but the applicable protest fee was not paid within the time limit specified in the invitation.
- No protest accompanied the payment of additional search fees.

## INTERNATIONAL SEARCH REPORT

Information on patent family members

International application No.

PCT/US2017/052501

Patent document cited in search report	Publication date	Patent family member(s)	Publication date
US 2016-0187594 A1	30/06/2016	AU 2014-215062 A1 CL 2015002179 A1 CN 104969107 A CN 104969107 B EP 2954358 A1 JP 2016-513275 A KR 10-2015-0132107 A MX 2015009915 A US 2014-0219614 A1 US 9285552 B2 US 9778424 B2 WO 2014-124004 A1	14/08/2014 22/04/2016 07/10/2015 03/10/2017 16/12/2015 12/05/2016 25/11/2015 25/09/2015 07/08/2014 15/03/2016 03/10/2017 14/08/2014
US 5688145 A	18/11/1997	None	
US 2012-0020634 A1	26/01/2012	CA 2675791 A1 CA 2675791 C CA 2944673 A1 CN 101617541 A CN 101617541 B CN 103281596 A CN 103281596 B MX 2009007633 A TW 200847802 A US 2008-0175551 A1 US 2008-0175552 A1 US 2010-0111482 A1 US 2010-0119201 A1 US 2012-0020633 A1 US 2014-0003783 A1 US 2014-0010511 A1 US 2015-0131958 A1 US 2015-0286021 A1 US 2015-0331214 A1 US 2015-0331215 A1 US 2015-0331216 A1 US 2015-0338593 A1 US 2015-0338594 A1 US 2015-0338595 A1 US 2015-0338597 A1 US 2015-0338598 A1 US 2015-0338599 A1 US 2017-0038549 A1 US 2017-0227727 A1 US 7570860 B2 US 7570861 B2 US 7873252 B2 US 7873253 B2 US 8340490 B2	24/07/2008 16/05/2017 24/07/2008 30/12/2009 01/05/2013 04/09/2013 16/03/2016 04/09/2009 01/12/2008 24/07/2008 24/07/2008 06/05/2010 13/05/2010 26/01/2012 02/01/2014 09/01/2014 14/05/2015 08/10/2015 19/11/2015 19/11/2015 19/11/2015 26/11/2015 26/11/2015 26/11/2015 26/11/2015 26/11/2015 26/11/2015 26/11/2015 26/11/2015 09/02/2017 10/08/2017 04/08/2009 04/08/2009 18/01/2011 18/01/2011 25/12/2012

## INTERNATIONAL SEARCH REPORT

Information on patent family members

International application No.

PCT/US2017/052501

Patent document cited in search report	Publication date	Patent family member(s)	Publication date
		US 8346044 B2	01/01/2013
		US 8867884 B2	21/10/2014
		US 8953921 B2	10/02/2015
		US 9097871 B2	04/08/2015
		US 9435974 B2	06/09/2016
		US 9435976 B2	06/09/2016
		US 9448378 B2	20/09/2016
		US 9448379 B2	20/09/2016
		US 9488796 B2	08/11/2016
		US 9638879 B2	02/05/2017
		US 9638880 B2	02/05/2017
		US 9645342 B2	09/05/2017
		US 9690066 B2	27/06/2017
		US 9703059 B2	11/07/2017
		US 9709764 B2	18/07/2017
		WO 2008-089190 A2	24/07/2008
		WO 2008-089190 A3	18/09/2008
WO 2013-109469 A1	25/07/2013	AU 2013-203864 A1	01/08/2013
		AU 2013-203864 B2	23/10/2014
		AU 2015-200320 A1	19/02/2015
		AU 2015-200320 B2	20/10/2016
		CN 104081241 A	01/10/2014
		CN 104081241 B	24/08/2016
		CN 106125204 A	16/11/2016
		EP 2805194 A1	26/11/2014
		IL 233673 D0	31/08/2014
		KR 10-2014-0112083 A	22/09/2014
		MX 2014008633 A	24/10/2014
		MX 341190 B	10/08/2016
		RU 2014133534 A	20/03/2016
		UA 114616 C2	10/07/2017
		US 2013-0183018 A1	18/07/2013
		US 2014-0191297 A1	10/07/2014
		US 2014-0377924 A1	25/12/2014
		US 2015-0277060 A1	01/10/2015
		US 2017-0131482 A1	11/05/2017
		US 8928086 B2	06/01/2015
		US 9075203 B2	07/07/2015
		US 9190520 B2	17/11/2015
		US 9429714 B2	30/08/2016
		US 9784923 B2	10/10/2017
		WO 2014-110005 A1	17/07/2014
EP 2922147 A1	23/09/2015	CN 104934772 A	23/09/2015
		JP 2015-185541 A	22/10/2015
		KR 10-1687475 B1	19/12/2016
		KR 10-2015-0110313 A	02/10/2015
		TW 201537834 A	01/10/2015
		TW I587581 B	11/06/2017

**INTERNATIONAL SEARCH REPORT**

Information on patent family members

International application No.

**PCT/US2017/052501**

Patent document cited in search report	Publication date	Patent family member(s)	Publication date
		US 2015-0270641 A1	24/09/2015
		US 9391398 B2	12/07/2016