



(11) **EP 3 564 460 B1**

(12) **EUROPEAN PATENT SPECIFICATION**

(45) Date of publication and mention of the grant of the patent:
26.05.2021 Bulletin 2021/21

(51) Int Cl.:
E04D 13/03^(2006.01)

(21) Application number: **19171526.7**

(22) Date of filing: **29.04.2019**

(54) **ROOF WINDOW WITH REINFORCEMENT IN FRAME TOP MEMBER**

DACHFENSTER MIT VERSTÄRKUNG IM RAHMENOBEBERTEIL

FENÊTRE DE TOIT AVEC RENFORCEMENT DANS L'ÉLÉMENT CHÂSSIS SUPÉRIEUR

(84) Designated Contracting States:
AL AT BE BG CH CY CZ DE DK EE ES FI FR GB GR HR HU IE IS IT LI LT LU LV MC MK MT NL NO PL PT RO RS SE SI SK SM TR

(30) Priority: **30.04.2018 DK PA201870253**

(43) Date of publication of application:
06.11.2019 Bulletin 2019/45

(73) Proprietor: **VKR Holding A/S**
2970 Hørsholm (DK)

(72) Inventor: **Haargaard, Pernille**
2970 Hørsholm (DK)

(74) Representative: **AWA Denmark A/S**
Strandgade 56
1401 Copenhagen K (DK)

(56) References cited:
EP-A1- 0 962 606 EP-A1- 3 128 097
WO-A1-2007/034171 DE-B1- 2 752 414
US-A- 5 553 425

EP 3 564 460 B1

Note: Within nine months of the publication of the mention of the grant of the European patent in the European Patent Bulletin, any person may give notice to the European Patent Office of opposition to that patent, in accordance with the Implementing Regulations. Notice of opposition shall not be deemed to have been filed until the opposition fee has been paid. (Art. 99(1) European Patent Convention).

Description**Title of Invention**

[0001] Roof window with reinforcement in frame top member.

Technical Field

[0002] The present invention relates to a roof window, particularly for installation in an inclined roof surface, comprising a frame having a plurality of frame members including a frame top member with an outer surface, and a reinforcement member formed as a separate element and connected to the outer surface of the frame top member in a mounted condition, the reinforcement member having a length dimension and a width dimension configured to cover a substantial part of the outer surface of the frame top member.

Background Art

[0003] When installing roof windows in a roof, the stationary frame is often mounted at a relatively early point in time relative to the finishing work including the subsequent connection of the sash and other components. The reasons for this are many, including the need for adapting the surrounding roofing on the external side and fitting lining panels on the internal side. During this period, the frame sits unprotected on the roof, and while the aperture which will later accommodate the sash is typically covered by a tarpaulin or the like, the frame itself is exposed in the roof surface. Installers, roofers, construction workers, architects and other people walk on the roof, and it sometimes happens that the top of the roof window is stepped upon, either involuntarily or in the belief that this is unproblematic. This applies in particular to the top member of the frame. As the frame top member is an element with some longitudinal extension but of a relatively slender thickness, and the sash is still not present to provide a counter force, the load from the weight leads to a bending moment that may be quite substantial, in addition to smudging the outer surface of the frame, which is less critical, the bending moment can at worst lead to cracks in the material of the frame top member and/or in the inner surface which will be visible in the mounted condition. To this end, it is customary to provide a separate reinforcement member fastened to the frame top member to prevent damaging. Typically, the reinforcement member is made of a piece of metal having such length, thickness and width dimensions that the reinforcement member covers a substantial part of the outer side of the corresponding frame top member. While metal is a well-known material with excellent strength properties, and which may furthermore be re-cycled after the life-span of the roof window, such a reinforcement member is most often fastened to the frame top member at the manufacturing site and hence adds to the weight

of the overall roof window. Furthermore, and more problematic, the metal reinforcement member constitutes a cold bridge in the mounted condition, thus detracting from the thermal properties of the roof window

[0004] EP0962606 A1 discloses a roof window with a capping strip having on its lower surface an insulation layer.

Summary of Invention

[0005] It is therefore the object of the invention to provide a roof window, in which the reinforcement of the frame top member is satisfactory but which at the same time makes it possible to provide improved insulating properties.

[0006] This is achieved with a roof window according to claim 1. The reinforcement member of such a roof window comprises at least a first profile of a metal material and a second profile of a plastic material releasably connected to each other. In addition to providing protection against smudging of the outer surface of the frame top member and elementary strength properties, the plastic second profile contributes to improving the insulating properties of the reinforcement member, while the metal first profile ensures that in particular resistance to bending is achieved. By forming the reinforcement member as a composite member which may be assembled and disassembled in a releasable manner, it is at the same time ascertained that the reinforcement member may be disposed of in an environmentally responsible manner.

[0007] Based on the recognition that the full-metal reinforcement member of the prior art was actually overdimensioned, the respective dimensions of the first profile and the second profile may be chosen appropriately. In a presently preferred embodiment, the length of the first and second profile is substantially identical, and the width of the second profile is larger than the width of the first profile by a factor in the range 2 to 10, preferably 4 to 8. Thus, letting the plastic second profile form the majority of the area of the reinforcement member ensures adequate insulating properties while retaining satisfactory strength. Even in such cases where the metal first profile only constitutes 10-20% of the total width of the reinforcement member, the mechanical properties have proven sufficient for normally occurring incidents.

[0008] According to the invention, the first profile comprises a base portion configured to extend substantially in parallel with the outer surface of the frame top member in the mounted condition and a leg portion extending substantially perpendicular to the base portion and comprising a first flange portion and a second flange portion, the first flange portion extending between the base portion and an upper edge and the second flange portion extending between the upper edge and a lower edge. By doubling the material of the first profile in this manner, a vast improvement in the strength of the reinforcement member is achieved in a simple manner.

[0009] In a further presently preferred embodiment, the

first profile is provided with engagement means to cooperate with receiving means in the second profile. In principle, such engagement means may be placed also on the second profile and the receiving means in the first profile, as long as the required releasable connection is formed in an operative manner. In a preferred development of this further preferred embodiment, the engagement means of the first profile comprises at least one perpendicular leg section extending from the base portion and at least one protruding leg section in conjunction with the perpendicular leg section and extending substantially in parallel with the base portion, preferably two perpendicular leg sections and two protruding leg sections are provided, the protruding leg sections preferably extending away from each other. In this manner, a form-locking engagement is achieved between the first and second profile, thus eliminating the risk of untimely release of the engagement.

[0010] In another presently preferred embodiment, the reinforcement member comprises a third profile in the form of a foam plate, preferably of an elastic polymer foam material having a thickness of 2 to 5 mm. This provides for additional insulation and protection of the frame top member. It is preferred that the foam plate is positioned on the side of the second profile opposite to the first profile and faces the outer surface of the frame top member in the mounted condition.

[0011] The material of the metal first profile may in principle be chosen in any suitable manner. It is preferred that the material is steel, preferably having a thickness of 0.5 to 1.5 mm, preferably coated with an alloy such as Al-Zn, and preferably formed by rolling. This provides for a durable component having excellent manufacturing and wear-resistant properties.

[0012] Correspondingly, the plastic material of the second profile may in principle be any material able to fulfil the requirements to durability, UV resistance etc. A suitable material and dimension has been found in Acrylonitrile butadiene styrene (ABS), preferably having a thickness of 2 to 5 mm, preferably reinforced by glass fibre, preferably having an E-modulus of at least 4 GPa and a tensile strength of at least 50 MPa as tested according to EN / ISO 527-2.

[0013] Other presently preferred embodiments and further advantages will be apparent from the subsequent appended claims, detailed description and drawings.

Brief Description of Drawings

[0014] In the following description embodiments of the invention will be described with reference to the schematic drawings, in which

Fig. 1 is a perspective view of a roof window, seen from the interior side and in an open position, including a prior art reinforcement member;

Fig. 2 is a perspective view, on a larger scale, of a prior art reinforcement member;

Fig. 3 is a perspective view of an embodiment of the reinforcement member of a roof window according to the invention;

Fig. 4 is an exploded plan view of the first profile and the second profile of the embodiment of the reinforcement member shown in Fig. 3;

Figs 5 and 6 are partial perspective views, seen from different angles, of an embodiment of the reinforcement member of the roof window according to the invention;

Fig. 7 is a partial perspective view of the first profile of the reinforcement member shown in Figs 5 and 6; and

Fig. 8 is a partial perspective sectional view of the reinforcement member of Figs 5 and 6.

Description of Embodiments

[0015] Referring initially to Fig. 1, the general configuration of a roof window which is top-hinged during normal operation and which pivots for cleaning is shown. Such a window is shown and described in further detail in Applicant's European patent No. 0 733 146 B1, the contents of which are hereby incorporated by reference.

[0016] The roof window here comprises a primary frame in the form of a stationary frame 1 configured for installation in an inclined roof surface. At least one secondary frame is connected to the stationary frame 1, in the embodiment shown a first secondary frame in the form of a sash 2 carrying a pane 4, and a second secondary frame in the form of an intermediate frame 3. The intermediate frame 3 is fastened to the stationary frame at a top mounting fitting 5, and the sash 2 is hinged at the top of the roof window, via the intermediate frame 3 to the stationary frame 1, to render the roof window top-hung during normal operation. The sash 2 is also pivotally connected to the intermediate frame 3 in order to be able to rotate the sash 2 to provide access to the outside of the pane 4, for instance for cleaning purposes. To that end, the intermediate frame 3 is provided with a frame hinge part 6 of pivot hinge fitting. Although not shown in detail, it is clear to the skilled person that the sash 2 is provided with the counterpart sash hinge part of the pivot hinge fitting. A lifting device 9 is provided to assist in the opening of the window, that is, bringing the secondary frame or frames to an angled position relative to the primary frame. Here, from a closed position, the user operates the operating device of the window in the form of a handle 7 at the bottom member of the sash 2. Finally, the roof window is provided with a ventilation device 8 acting to allow passage of air also in the closed position of the window.

[0017] Although a top-hung roof window is shown and described, the principles underlying the invention are generally applicable to all types of roof windows though, including roof windows pivoting about a central axis, about an axis offset from the centre, and top-hung skylights which do not pivot for cleaning, and fixed, i.e. non-

openable skylights.

[0018] In Fig. 1, a prior art reinforcement member 10' is indicated on the top member of the frame 1. As is customary in the art, the reinforcement member 10' is made fully of metal.

[0019] In the following, embodiments of a reinforcement member 10 of a roof window according to the invention will be described with reference to Figs 3 to 8. It is understood that the reinforcement member 10 in its mounted condition is connected to the outer surface of the frame top member of a roof window as the one shown in Fig. 1, and that the drawing figures referred to show the reinforcement members for reasons of easy readability. Furthermore, it is recognised that the reinforcement member 10 has a length dimension and a width dimension configured to cover a substantial part of the outer surface of the frame top member. As roof windows come in different sizes, it is understood that the person skilled in the art will be able to select such suitable length and width dimensions without undue burden.

[0020] Referring first to Figs 3 and 4, it is shown how the reinforcement member 10 comprises at least a first profile 20 of a metal material and a second profile 30 of a plastic material releasably connected to each other.

[0021] In the embodiment shown, the length L of the first profile 20 and the second profile 30 is substantially identical, thus corresponding to a major part of the length of the frame top member. The width W2 of the second profile 30 is larger than the width W1 of the first profile 20 by a factor in the range 2 to 10, preferably 4 to 8. As the first profile 20 and the second profile overlap somewhat in the assembled condition, the combined width of the respective width dimensions W1 and W2 is larger than the resultant width of the assembled reinforcement member. Again, it is recognised that the person skilled in the art will choose suitable values of the width dimensions to fit the outer side of the frame top member.

[0022] Turning now to Figs 5 to 8, the configurations of the first and second profiles in a specific embodiment will be described in more detail. Thus, the first profile 20 comprises a base portion 21 configured to extend substantially in parallel with the outer surface of the frame top member in the mounted condition and a leg portion extending substantially perpendicular to the base portion 21 and comprising a first flange portion 22 and a second flange portion 24, the first flange portion 22 extending between the base portion 21 and an upper edge 23a and the second flange portion 24 extending between the upper edge 23a and a lower edge 23b. Another advantageous feature of this embodiment is that the transitions between the individual portions of the first profile are rounded to increase the strength properties even further, but also to provide better handling characteristics, as the lack of sharp edges will reduce the risk of damage to people and property. Also from a manufacturing point of view, the rounded edges are an advantage, since metal forming techniques such as rolling may be used. The metal material of the first profile 20 is here steel, for in-

stance in the form of sheet metal with a suitable thickness of for instance 0.5 to 1.5 mm. The sheet metal is preferably coated with an alloy such as Al-Zn to increase durability and resistance to corrosion.

[0023] As shown, the distance between the upper edge 23a and the lower edge 23b is larger than the distance between the upper edge 23a and the base portion 21 such that the second flange portion 24 protrudes below the base portion 21. In turn, this entails that the second flange portion 24 may be positioned around the transition between the outer surface of the frame top member and an inner surface of the frame top member.

[0024] Shown most clearly in Fig. 7, a third flange portion 26 is provided in conjunction with the second flange portion 24, extending from the lower edge 23b up to substantially an underside of the base portion 21. This increases the strength of the first profile 20 even further.

[0025] Furthermore, a hook portion 25 is in the embodiment shown formed in conjunction with the second flange portion 24 and also the third flange portion 26, in at least one longitudinal end, here both ends, of the first profile 20 to extend beyond the length L of the first profile 20, measured on the parts other than the hook portion or portions 25.

[0026] In order to ensure that the releasable connection between the first profile and the second profile is able to be carried out in a reliable manner, the first profile 20 is provided with engagement means 27 to cooperate with receiving means 37 in the second profile 30. This will be described in further detail below.

[0027] Turning again specifically to Fig. 7, it is seen how in the embodiment shown, the engagement means 27 of the first profile 20 comprises at least one perpendicular leg section 28a extending from the base portion 21 and at least one protruding leg section 29a in conjunction with the perpendicular leg section 28a and extending substantially in parallel with the base portion 21. Here, there are two perpendicular leg sections 28a, 28b and two protruding leg sections 29a, 29b are provided, the protruding leg sections 29a, 29b extending away from each other. In the specific embodiment shown, the leg sections have been formed by cut-out and bent sections of the base portion 21, confer the presence of openings 21a and 21b in the base portion 21.

[0028] The second profile 30 comprises, in the embodiment shown, a substantially plane base portion 31 in which a number of apertures are provided, including at least a plurality of holes 34, 35 for receiving fastening means, said plurality preferably including openings and/or cut-outs 32, 33 for accommodating parts of the roof window. Although not shown in detail, it is apparent that such fastening means may include screws with appropriate head size to fasten the reinforcement member 10 to the outer surface of the frame top member. The plastic material of the second profile 30 is here chosen as an Acrylonitrile butadiene styrene (ABS). The thickness of the second profile is chosen in accordance with the material parameters and the desired properties. It

could have also have a density in the range of 1100-1220 g/cm³ and a thermal conductivity in the range of $\lambda=0,1-0,26$ W/mK. The second profile 30 may be reinforced by glass fibre, and should preferably show an E-modulus of at least 4 GPa and a tensile strength of at least 50 MPa as tested according to EN / ISO 527-2. Typically, a thickness in the range 2 to 5 mm will be suitable.

[0029] One of the plurality of apertures here includes an aperture 37 forming the receiving means cooperating with the engagement means 27 of the first profile 20. As indicated in Fig. 7, the aperture 37 forming the receiving means has such dimensions that at least one perpendicular leg section 28a, 28b fits in the aperture but the at least one protruding leg section 29a, 29b at least partly protrudes beyond the aperture 37.

[0030] Eventually, the reinforcement member 10 comprises, as shown in Figs 5 to 6 and 8, a third profile in the form of a foam plate 40, preferably of an elastic polymer foam material such as a polyethylene foam, with a density in the range of $m=15-100$ g/cm³ and a thermal conductivity in the range of $\lambda=0,02-0,06$ W/mK, having a thickness of 2 to 5 mm.

[0031] In the embodiment shown, the foam plate 40 is positioned on the side of the second profile 30 opposite to first profile 20 and faces the outer surface of the frame top member in the mounted condition. The foam plate 40 also covers the protruding leg sections 29a, 29b in the mounted condition. The connection between the foam plate 40 and the second profile 30 may be carried out in any suitable manner, for instance by an adhesive; however, the entire reinforcement member 10 is fastened to the outer surface of the frame top member, and the foam plate 40 is placed entirely below the second profile 30 in the mounted condition.

[0032] The reinforcement member 10 is provided on the roof window according to the invention by first forming the first profile 20, the second profile 30 and optionally the third profile or foam plate 40 individually. Subsequently, the first profile 20 is releasably connected to the second profile 30, in the embodiment shown by engaging the engagement means 27 of the first profile with the receiving means of the second profile by inserting the leg sections 28a, 28b, 29a, 29b into the aperture 37 in the second profile 30. The foam plate 40 is either attached to the second profile before or after the engagement. Thus, the reinforcement member 10 is now in the form of a separate element and will be fastened to the frame top member to provide the finished roof window.

[0033] In the following, various configurations of the reinforcement member will be described by comparative examples, taking their outset in a reinforcement member with a length L of 980 mm and a total width of 80 mm and material properties within the ranges described above for the various materials.

[0034] The properties of the reinforcement member 10 in respect of its insulating properties vary depending of the actual dimensions, but improvements in the overall

U-value for the member falls within a range of 0.005 to 0.03 W/m²K as described in more detail in the following examples I-III.

5 Example I

[0035] By reducing the cross sectional area of the metal first profile from 120 mm² as in the prior art constructions to 40 mm² and having inserted a plastic second profile with a cross sectional area of approximately 300 mm², and having the foam third profile with an area of 100 mm² calculations show that an improvement in the overall U-value ranging from 0.005 to 0.01 W/m²K could be obtained.

10 Example II

[0036] Having a metal first profile and a plastic second profile as described in Example I and a foam third profile with a cross sectional area of approximately 200 mm², an improvement in the U-value could be calculated to fall within the range of 0.009 to 0.018 W/m²K.

15 Example III

[0037] Having a metal first profile as described in Example I and a foam third profile as described in Example II and a plastic second profile with a thickness of 5 mm, an improvement in the U-value could be calculated to fall within the range of 0.01 to 0.026 W/m²K.

[0038] The invention is not limited to the embodiments shown and described in the above, but various modifications and combinations may be carried out within the scope of the appended claims.

20 List of reference numerals

[0039]

40	1	primary frame (stationary frame)
	2	first secondary frame (sash)
	3	second secondary frame (intemediate frame)
	4	pane
	5	top mounting fitting
45	6	frame hinge part of pivot hinge fitting
	7	handle
	8	ventilation device
	9	lifting device
	10	reinforcement member
50	20	first profile
	21	base portion
	21a	opening
	21b	opening
	22	first flange portion
55	23a	upper edge
	23b	lower edge
	24	second flange portion
	25	hook portion

26	third flange portion
27	engagement means
28a	perpendicular leg section
29a	protruding leg section
28b	perpendicular leg section
29b	protruding leg section
30	second profile
31	base portion
32	cut-out
33	opening
34	hole
35	hole
37	receiving means / aperture
40	third profile / foam plate

Claims

1. A roof window, particularly for installation in an inclined roof surface, comprising a frame (1) having a plurality of frame members including a frame top member with an outer surface, and a reinforcement member (10) formed as a separate element and connected to the outer surface of the frame top member, the reinforcement member (10) having a length dimension (L) and a width dimension covering a substantial part of the outer surface of the frame top member,

characterised in that

the reinforcement member (10) comprises at least a first profile (20) of a metal material and a second profile (30) of a plastic material releasably connected to each other, wherein the first profile (20) comprises a base portion (21) configured to extend substantially in parallel with the outer surface of the frame top member in the mounted condition and a leg portion extending substantially perpendicular to the base portion (21) and said leg portion comprising a first flange portion (22) and a second flange portion (24), the first flange portion (22) extending between the base portion (21) and an upper edge (23a) and the second flange portion (24) extending between the upper edge (23a) and a lower edge (23b).

2. A roof window according to claim 1, wherein the length (L) of the first profile (20) and the second profile (30) is substantially identical, and wherein the width (W2) of the second profile (30) is larger than the width (W1) of the first profile (20) by a factor in the range 2 to 10, preferably 4 to 8.
3. A roof window according to claim 2, wherein the distance between the upper edge (23a) and the lower edge (23b) is larger than the distance between the upper edge (23a) and the base portion (21) such that the second flange portion (24) protrudes below the base portion (21).

4. A roof window according to claim 3, wherein a third flange portion (26) is provided in conjunction with the second flange portion (24), extending from the lower edge (23b) up to substantially an underside of the base portion (21).

5. A roof window according to any one of claims 3 and 4, wherein a hook portion (25) is formed in conjunction with at least the second flange portion (24), optionally also the third flange portion (26), in at least one longitudinal end of the first profile (20) to extend beyond the length (L) of the first profile (20), measured on the parts other than the hook portion or portions (25).

6. A roof window according to any one of the preceding claims, wherein at least the first profile (20) is provided with engagement means (27) to cooperate with receiving means (37) in the second profile (30).

7. A roof window according to claim 6, wherein the engagement means (27) of the first profile (20) comprises at least one perpendicular leg section (28a) extending from the base portion (21) and at least one protruding leg section (29a) in conjunction with the perpendicular leg section (28a) and extending substantially in parallel with the base portion (21), preferably two perpendicular leg sections (28a, 28b) and two protruding leg sections (29a, 29b) are provided, the protruding leg sections (29a, 29b) preferably extending away from each other.

8. A roof window according to any one of the preceding claims, wherein the second profile (30) comprises a substantially plane base portion (31) in which a number of apertures are provided, including at least a plurality of holes (34, 35) for receiving fastening means, said plurality preferably including openings and/or cut-outs (32, 33) for accommodating parts of the roof window.

9. A roof window according to claim 6 and 8, wherein said plurality of apertures includes an aperture (37) forming the receiving means cooperating with the engagement means (27) of the first profile (20).

10. A roof window according to claim 7 and 9, wherein the aperture (37) forming the receiving means has such dimensions that the at least one perpendicular leg section (28a, 28b) fits in the aperture but the at least one protruding leg section (29a, 29b) at least partly protrudes beyond the aperture (37).

11. A roof window according to any one of the preceding claims, wherein the reinforcement member (10) comprises a third profile in the form of a foam plate (40), preferably of an elastic polymer foam material having a thickness of 2 to 5 mm.

12. A roof window according to claim 11, wherein the foam plate (40) is positioned on the side of the second profile (30) opposite to first profile (20) and faces the outer surface of the frame top member in the mounted condition.
13. A roof window according to claim 10 and 12, wherein the foam plate (40) covers the at least one protruding leg section (29a, 29b) in the mounted condition.
14. A roof window according to any one of preceding claims, wherein the metal material of the first profile (20) is steel, preferably having a thickness of 0.5 to 1.5 mm, preferably coated with an alloy such as Al-Zn, and preferably formed by rolling.
15. A roof window according to any one of the preceding claims, wherein the plastic material of the second profile (30) is Acrylonitrile butadiene styrene (ABS), preferably having a thickness of 2 to 5 mm, preferably reinforced by glass fibre, preferably having an E-modulus of at least 4 GPa and a tensile strength of at least 50 MPa as tested according to EN /ISO 527-2.

Patentansprüche

1. Dachfenster, insbesondere zum Einbau in eine geneigte Dachfläche, umfassend einen Rahmen (1) mit einer Vielzahl von Rahmenelementen, einschließlich eines Rahmenoberteils mit einer Außenfläche, und ein Verstärkungselement (10), das als separates Element ausgebildet und mit der Außenfläche des Rahmenoberteils verbunden ist, wobei das Verstärkungselement (10) eine Längenabmessung (L) und eine Breitenabmessung aufweist, die einen wesentlichen Teil der Außenfläche des Rahmenoberteils abdeckt,
dadurch gekennzeichnet, dass
das Verstärkungselement (10) mindestens ein erstes Profil (20) aus einem Metallmaterial und ein zweites Profil (30) aus einem Kunststoffmaterial umfasst, die lösbar miteinander verbunden sind, wobei das erste Profil (20) einen Basisabschnitt (21), der dazu ausgelegt ist, sich im montierten Zustand im Wesentlichen parallel zur Außenfläche des Rahmenoberteils zu erstrecken, und einen Schenkelabschnitt umfasst, der sich im Wesentlichen rechtwinklig zum Basisabschnitt (21) erstreckt, wobei der Schenkelabschnitt umfasst:
einen ersten Flanschabschnitt (22) und einen zweiten Flanschabschnitt (24), wobei sich der erste Flanschabschnitt (22) zwischen dem Basisabschnitt (21) und einer Oberkante (23a) und der zweite Flanschabschnitt (24) zwischen der Oberkante (23a) und einer Unterkante (23b) erstreckt.
2. Dachfenster gemäß Anspruch 1, wobei die Länge (L) des ersten Profils (20) und des zweiten Profils (30) im Wesentlichen identisch ist, und wobei die Breite (W2) des zweiten Profils (30) um einen Faktor im Bereich von 2 bis 10, vorzugsweise 4 bis 8, größer als die Breite (W1) des ersten Profils (20) ist.
3. Dachfenster gemäß Anspruch 2, wobei der Abstand zwischen der Oberkante (23a) und der Unterkante (23b) größer als der Abstand zwischen der Oberkante (23a) und dem Basisabschnitt (21) ist, sodass der zweite Flanschabschnitt (24) unter den Basisabschnitt (21) ragt.
4. Dachfenster gemäß Anspruch 3, wobei ein dritter Flanschabschnitt (26) in Verbindung mit dem zweiten Flanschabschnitt (24) vorgesehen ist, der sich von der Unterkante (23b) bis im Wesentlichen zu einer Unterseite des Basisabschnitts (21) erstreckt.
5. Dachfenster gemäß einem der Ansprüche 3 und 4, wobei ein Hakenabschnitt (25) in Verbindung mit mindestens dem zweiten Flanschabschnitt (24), gegebenenfalls auch dem dritten Flanschabschnitt (26), in mindestens einem Längsende des ersten Profils (20) ausgebildet ist, um sich über die Länge (L) des ersten Profils (20), gemessen an den anderen Teilen als dem Hakenabschnitt oder den Hakenabschnitten (25), zu erstrecken.
6. Dachfenster gemäß einem der vorhergehenden Ansprüche, wobei mindestens das erste Profil (20) mit Eingriffsmitteln (27) versehen ist, um mit Aufnahmemitteln (37) im zweiten Profil (30) zusammenzuwirken.
7. Dachfenster gemäß Anspruch 6, wobei die Eingriffsmittel (27) des ersten Profils (20) mindestens einen rechtwinkligen Schenkelabschnitt (28a), der sich vom Basisabschnitt (21) aus erstreckt, und mindestens einen vorstehenden Schenkelabschnitt (29a) in Verbindung mit dem senkrechten Schenkelabschnitt (28a), der sich im wesentlichen parallel zum Basisteil (21) erstreckt, umfassen, wobei vorzugsweise zwei rechtwinklige Schenkelabschnitte (28a, 28b) und zwei vorstehende Schenkelabschnitte (29a, 29b) vorgesehen sind, wobei sich die vorstehenden Schenkelabschnitte (29a, 29b) vorzugsweise voneinander weg erstrecken.
8. Dachfenster gemäß einem der vorhergehenden Ansprüche, wobei das zweite Profil (30) einen im Wesentlichen ebenen Basisabschnitt (31) umfasst, in dem eine Anzahl von Öffnungen vorgesehen ist, einschließlich mindestens einer Vielzahl von Löchern (34, 35) zum Aufnehmen von Befestigungsmitteln, wobei die Vielzahl vorzugsweise Öffnungen und/oder Ausschnitte (32, 33) zum Aufnehmen von

Teilen des Dachfensters enthält.

9. Dachfenster gemäß Anspruch 6 und 8, wobei die Vielzahl von Öffnungen eine Öffnung (37) umfasst, die das Aufnahmemittel bildet, das mit dem Eingriffsmittel (27) des ersten Profils (20) zusammenwirkt. 5
10. Dachfenster gemäß Anspruch 7 und 9, wobei die das Aufnahmemittel bildende Öffnung (37) so dimensioniert ist, dass der mindestens eine rechteckige Schenkelabschnitt (28a, 28b) in die Öffnung passt, der mindestens eine vorstehende Schenkelabschnitt (29a, 29b) aber mindestens teilweise über die Öffnung (37) hinausragt. 10
11. Dachfenster gemäß einem der vorhergehenden Ansprüche, wobei das Verstärkungselement (10) ein drittes Profil in Form einer Schaumplatte (40), vorzugsweise aus einem elastischen Polymerschaumstoffmaterial mit einer Dicke von 2 bis 5 mm, aufweist. 15
12. Dachfenster gemäß Anspruch 11, wobei die Schaumstoffplatte (40) auf der dem ersten Profil (20) gegenüberliegenden Seite des zweiten Profils (30) angeordnet ist und im montierten Zustand der Außenfläche des Rahmenoberteils zugewandt ist. 20
13. Dachfenster gemäß Anspruch 10 und 12, wobei die Schaumstoffplatte (40) im montierten Zustand den mindestens einen vorstehenden Schenkelabschnitt (29a, 29b) abdeckt. 25
14. Dachfenster gemäß einem der vorhergehenden Ansprüche, wobei das Metallmaterial des ersten Profils (20) Stahl ist, vorzugsweise mit einer Dicke von 0,5 bis 1,5 mm, vorzugsweise mit einer Legierung wie Al-Zn beschichtet und vorzugsweise durch Walzen geformt. 30
15. Dachfenster gemäß einem der vorhergehenden Ansprüche, wobei das Kunststoffmaterial des zweiten Profils (30) Acrylnitril-Butadien-Styrol (ABS) ist, vorzugsweise mit einer Dicke von 2 bis 5 mm, vorzugsweise mit Glasfaser verstärkt, vorzugsweise mit einem E-Modul von mindestens 4 GPa und einer Zugfestigkeit von mindestens 50 MPa laut Prüfung gemäß EN/ISO 527-2. 35

Revendications

1. Fenêtre de toit, en particulier pour une installation dans une surface de toit inclinée, comprenant un châssis (1) ayant une pluralité d'éléments châssis comprenant un élément châssis supérieur avec une surface extérieure, et un élément renforcement (10) formé comme un élément séparé et relié à la surface 40

extérieure de l'élément châssis supérieur, l'élément renforcement (10) ayant une dimension en longueur (L) et une dimension en largeur couvrant une partie substantielle de la surface extérieure de l'élément châssis supérieur, **caractérisé en ce que** l'élément renforcement (10) comprend au moins un premier profilé (20) en matériau métallique et un deuxième profilé (30) en matière plastique reliés l'un à l'autre de manière amovible, le premier profilé (20) comprenant une partie de base (21) conçue pour s'étendre sensiblement parallèlement à la surface extérieure de l'élément châssis supérieur dans l'état monté et une partie de jambe s'étendant sensiblement perpendiculairement à la partie de base (21) et ladite partie de jambe comprenant une première partie de bride (22) et une deuxième partie de bride (24), la première partie de bride (22) s'étendant entre la partie de base (21) et un bord supérieur (23a) et la deuxième partie de bride (24) s'étendant entre le bord supérieur (23a) et un bord inférieur (23b). 5

2. Fenêtre de toit selon la revendication 1, la longueur (L) du premier profilé (20) et du second profilé (30) étant sensiblement identique, et la largeur (W2) du second profilé (30) étant supérieure à la largeur (W1) du premier profilé (20) d'un facteur dans la plage de 2 à 10, de préférence de 4 à 8. 10

3. Fenêtre de toit selon la revendication 2, la distance entre le bord supérieur (23a) et le bord inférieur (23b) étant plus grande que la distance entre le bord supérieur (23a) et la partie de base (21) de sorte que la deuxième partie de bride (24) fasse saillie en dessous de la partie de base (21). 15

4. Fenêtre de toit selon la revendication 3, une troisième partie de bride (26) étant fournie conjointement avec la deuxième partie de bride (24), s'étendant depuis le bord inférieur (23b) jusqu'à sensiblement un côté inférieur de la partie de base (21). 20

5. Fenêtre de toit selon l'une quelconque des revendications 3 et 4, une partie de crochet (25) étant formée conjointement avec au moins la deuxième partie de bride (24), éventuellement aussi avec la troisième partie de bride (26), dans au moins une extrémité longitudinale du premier profilé (20) pour s'étendre au-delà de la longueur (L) du premier profilé (20), mesurée sur les parties autres que la partie ou les parties de crochet (25). 25

6. Fenêtre de toit selon l'une quelconque des revendications précédentes, au moins le premier profilé (20) étant muni d'un moyen de mise en prise (27) pour coopérer avec un moyen de réception (37) dans le deuxième profilé (30). 30

7. Fenêtre de toit selon la revendication 6, le moyen de 35

- mise en prise (27) du premier profilé (20) comprenant au moins une section de jambe perpendiculaire (28a) s'étendant depuis la partie de base (21) et au moins une section de jambe en saillie (29a) conjointement avec la section de jambe perpendiculaire (28a) et s'étendant sensiblement parallèlement à la partie de base (21), de préférence deux sections de jambe perpendiculaire (28a, 28b) et deux sections de jambe en saillie (29a, 29b) étant fournies, les sections de jambe en saillie (29a, 29b) s'étendant de préférence à l'opposé l'une de l'autre.
8. Fenêtre de toit selon l'une quelconque des revendications précédentes, le deuxième profilé (30) comprenant une partie de base (31) sensiblement plane dans laquelle un certain nombre d'ouvertures sont pratiquées, comprenant au moins une pluralité de trous (34, 35) pour recevoir un moyen de fixation, ladite pluralité comprenant de préférence des ouvertures et/ou des découpes (32, 33) pour recevoir des parties de la fenêtre de toit.
9. Fenêtre de toit selon la revendication 6 et 8, ladite pluralité d'ouvertures comprenant une ouverture (37) formant le moyen de réception coopérant avec le moyen de mise en prise (27) du premier profilé (20).
10. Fenêtre de toit selon la revendication 7 et 9, l'ouverture (37) formant le moyen de réception ayant des dimensions telles que l'au moins une section de jambe perpendiculaire (28a, 28b) s'insère dans l'ouverture mais l'au moins une section de jambe en saillie (29a, 29b) fasse au moins partiellement saillie au-delà de l'ouverture (37).
11. Fenêtre de toit selon l'une quelconque des revendications précédentes, l'élément renforcement (10) comprenant un troisième profilé sous la forme d'une plaque de mousse (40), de préférence en matériau de mousse polymère élastique ayant une épaisseur de 2 à 5 mm.
12. Fenêtre de toit selon la revendication 11, la plaque de mousse (40) étant positionnée sur le côté du deuxième profilé (30) opposé au premier profilé (20) et faisant face à la surface extérieure de l'élément de châssis supérieur dans l'état monté.
13. Fenêtre de toit selon la revendication 10 et 12, la plaque de mousse (40) recouvrant l'au moins une section de jambe en saillie (29a, 29b) dans l'état monté.
14. Fenêtre de toit selon l'une quelconque des revendications précédentes, le matériau métallique du premier profilé (20) étant de l'acier, ayant de préférence une épaisseur de 0,5 à 1,5 mm, de préférence revêtu d'un alliage tel que Al-Zn, et de préférence formé par laminage.
15. Fenêtre de toit selon l'une quelconque des revendications précédentes, la matière plastique du deuxième profilé (30) étant de l'Acrylonitrile butadiène styrène (ABS), ayant de préférence une épaisseur de 2 à 5 mm, de préférence renforcé de fibre de verre, ayant de préférence un module E d'au moins 4 GPa et une résistance à la traction d'au moins 50 MPa testée selon la norme EN / ISO 527-2.

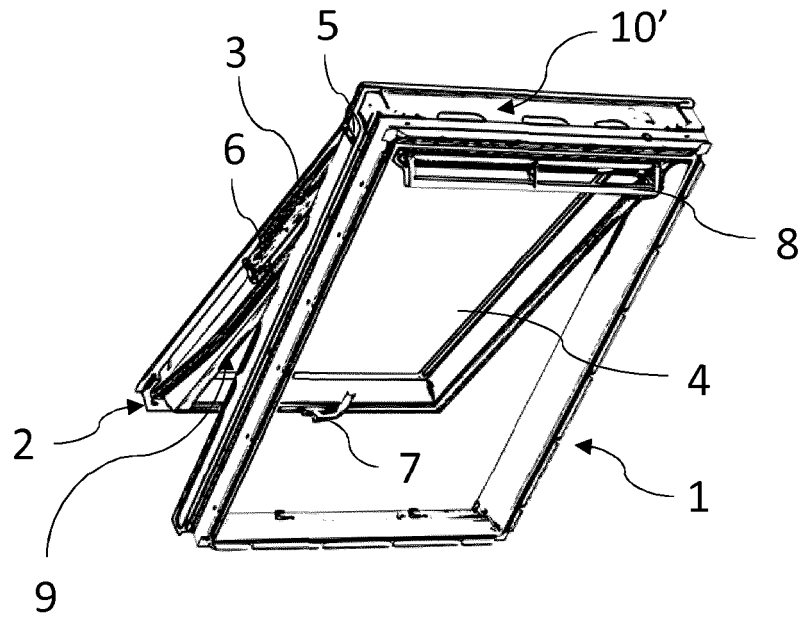

Fig. 1 (PRIOR ART)

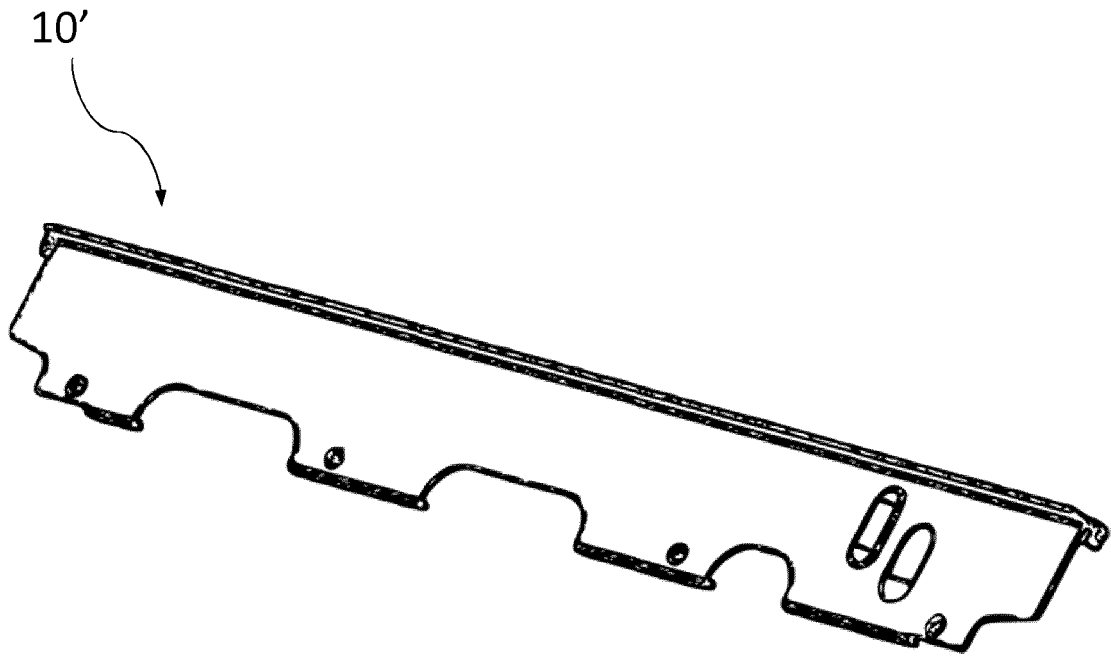

Fig. 2 (PRIOR ART)

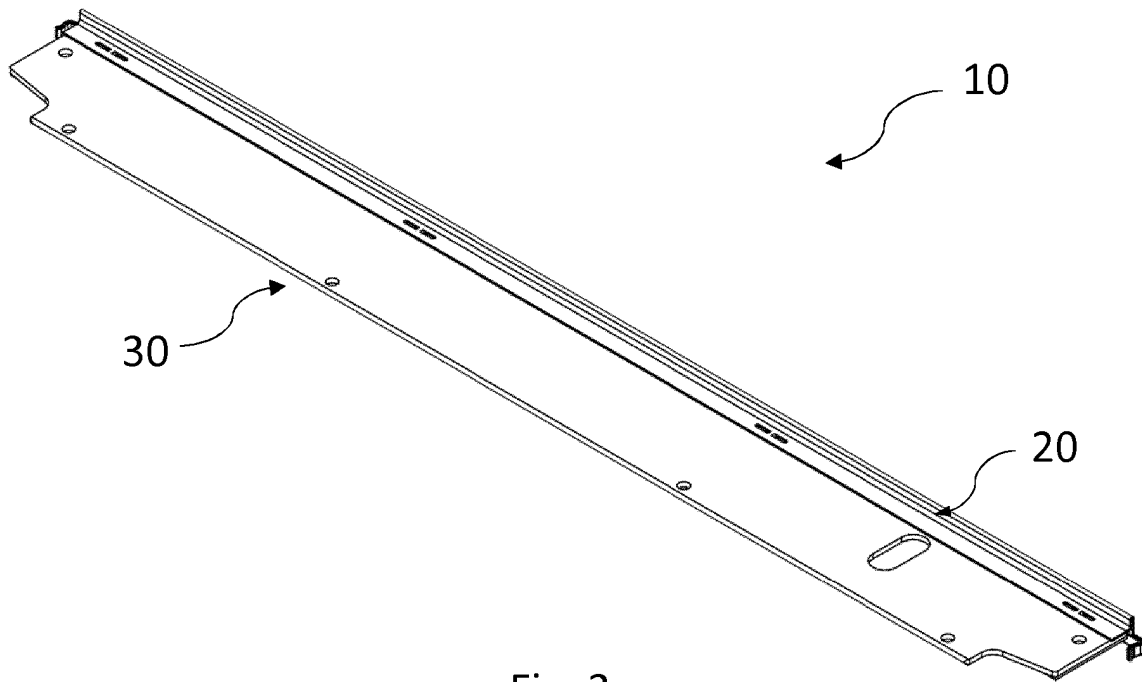

Fig. 3

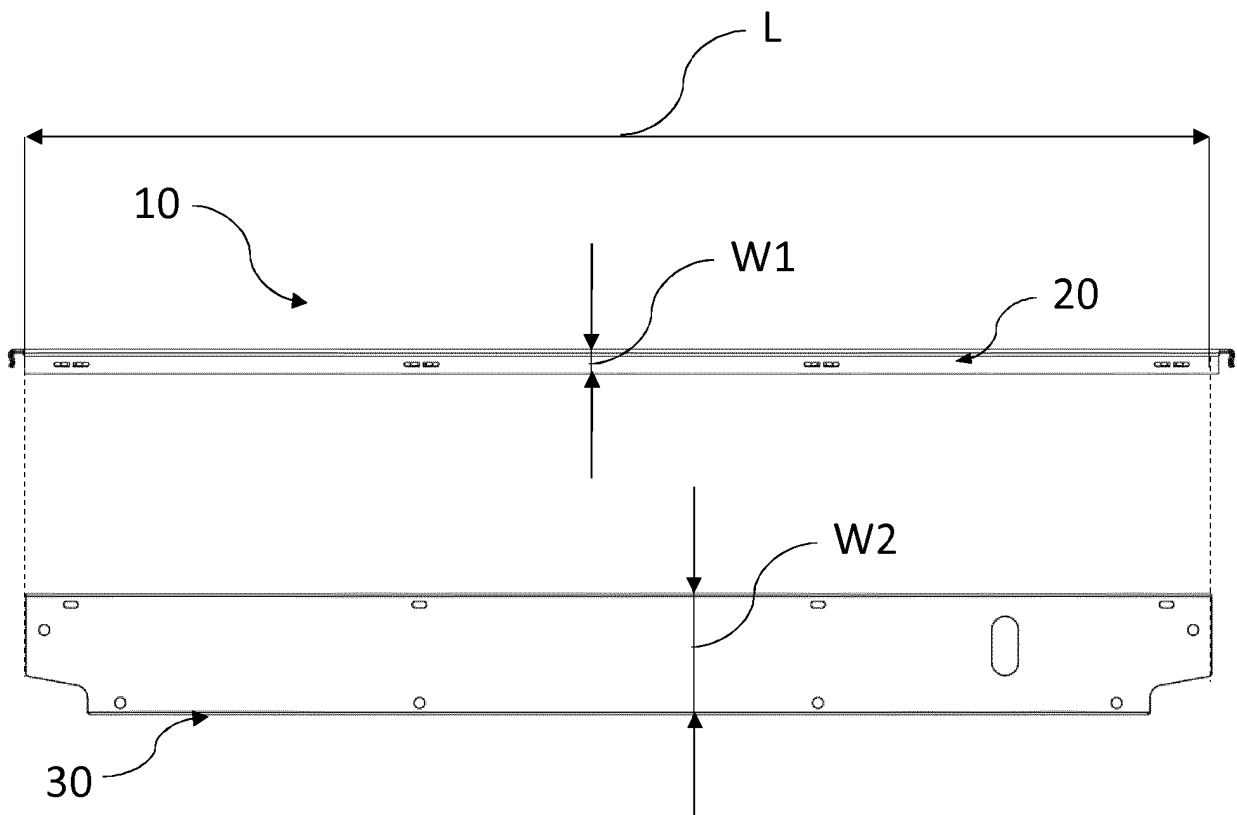

Fig. 4

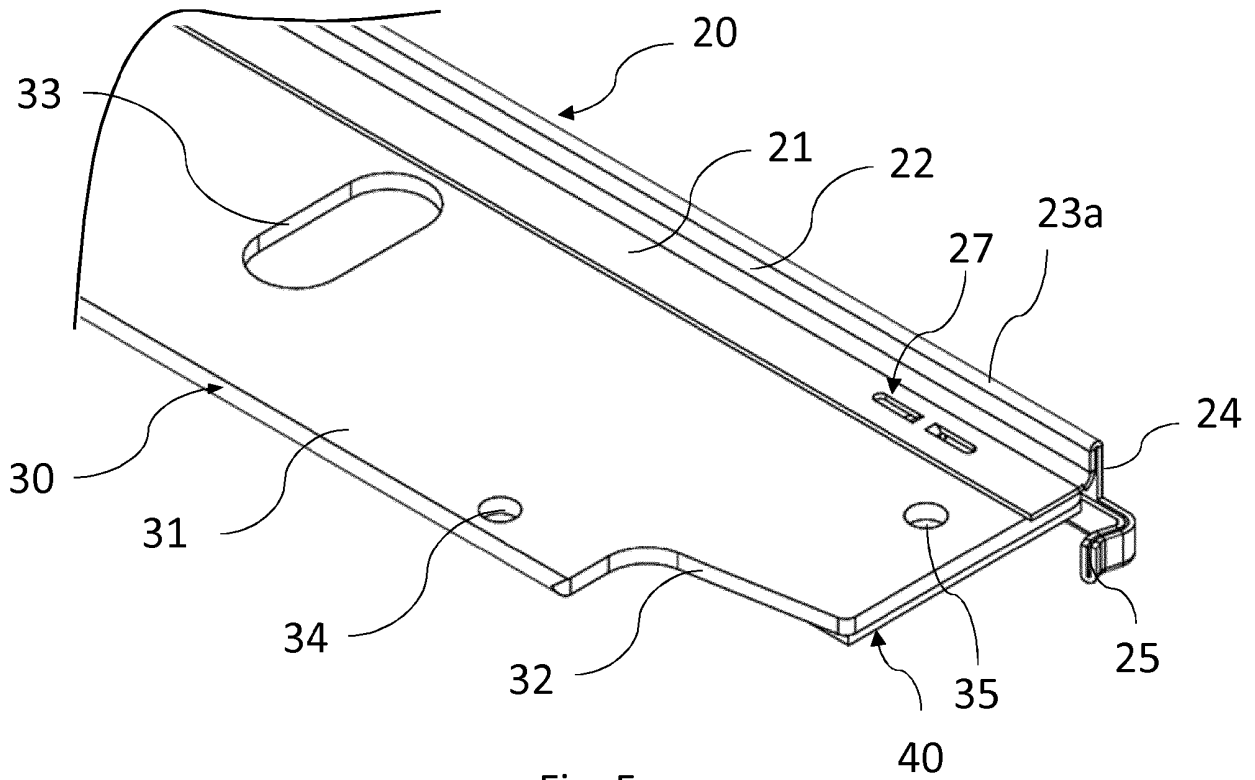

Fig. 5

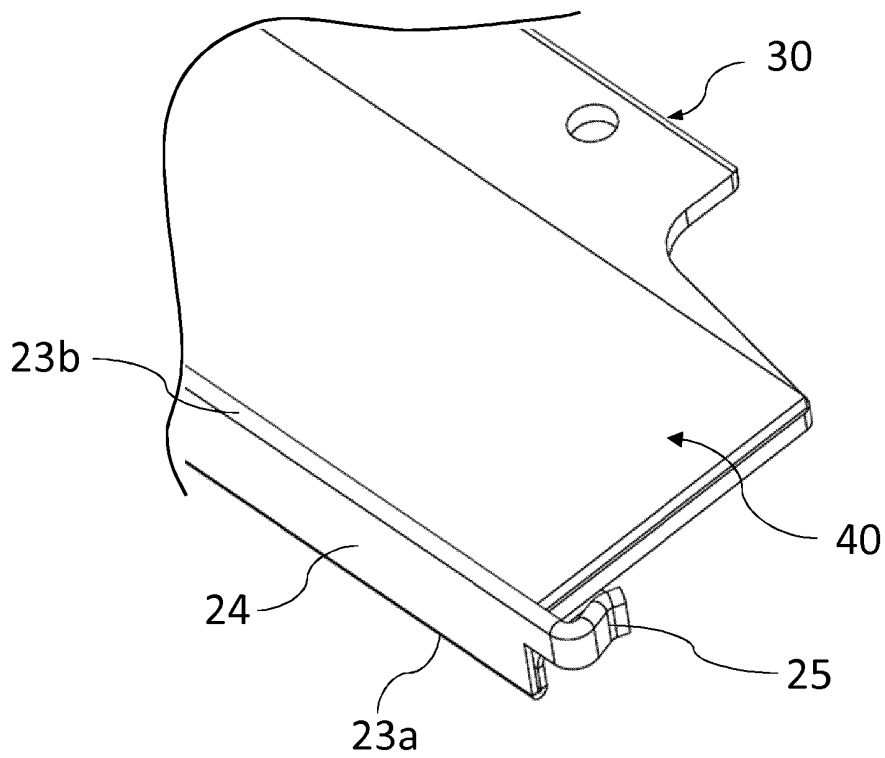

Fig. 6

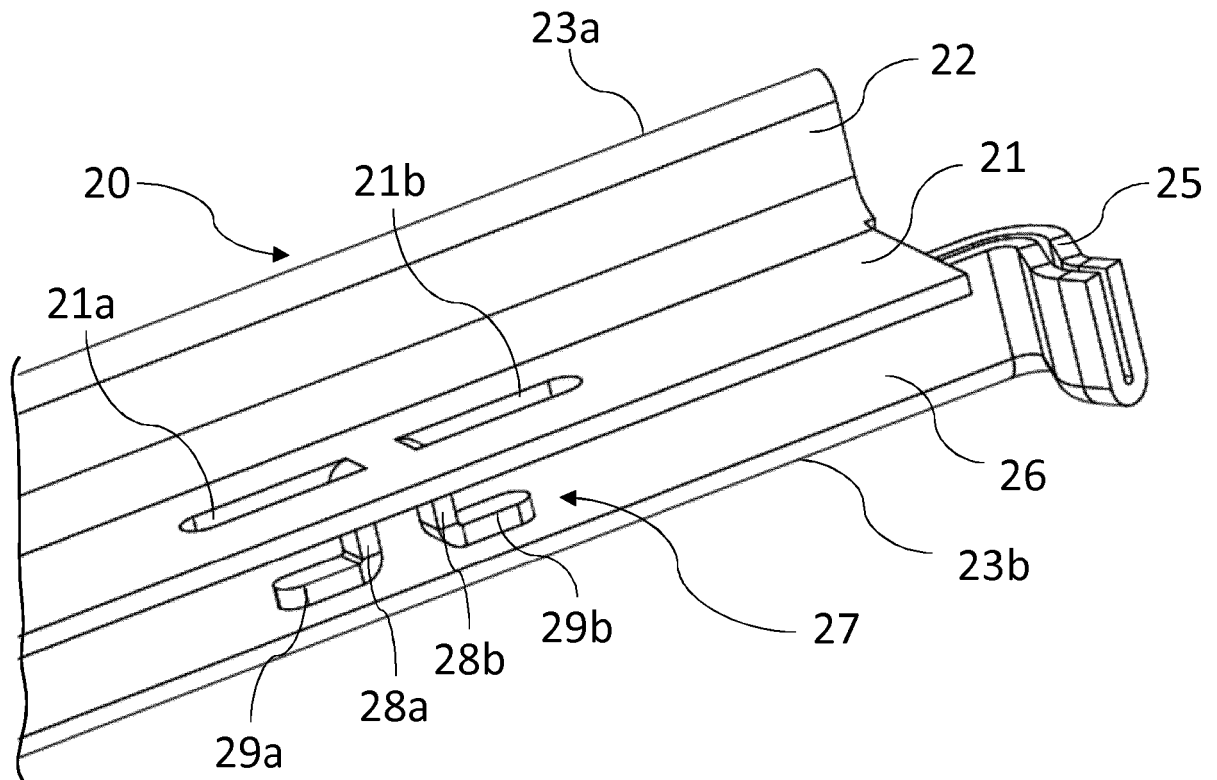

Fig. 7

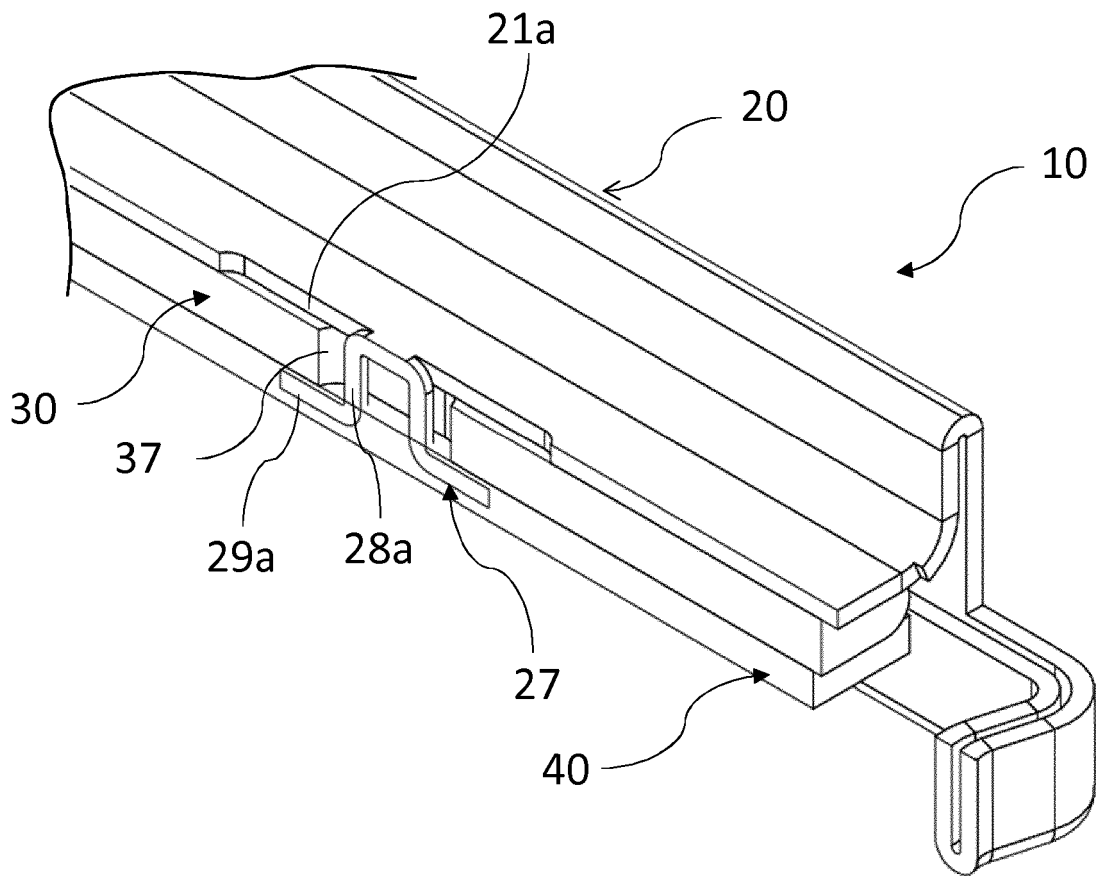

Fig. 8

REFERENCES CITED IN THE DESCRIPTION

This list of references cited by the applicant is for the reader's convenience only. It does not form part of the European patent document. Even though great care has been taken in compiling the references, errors or omissions cannot be excluded and the EPO disclaims all liability in this regard.

Patent documents cited in the description

- EP 0962606 A1 **[0004]**
- EP 0733146 B1 **[0015]**