

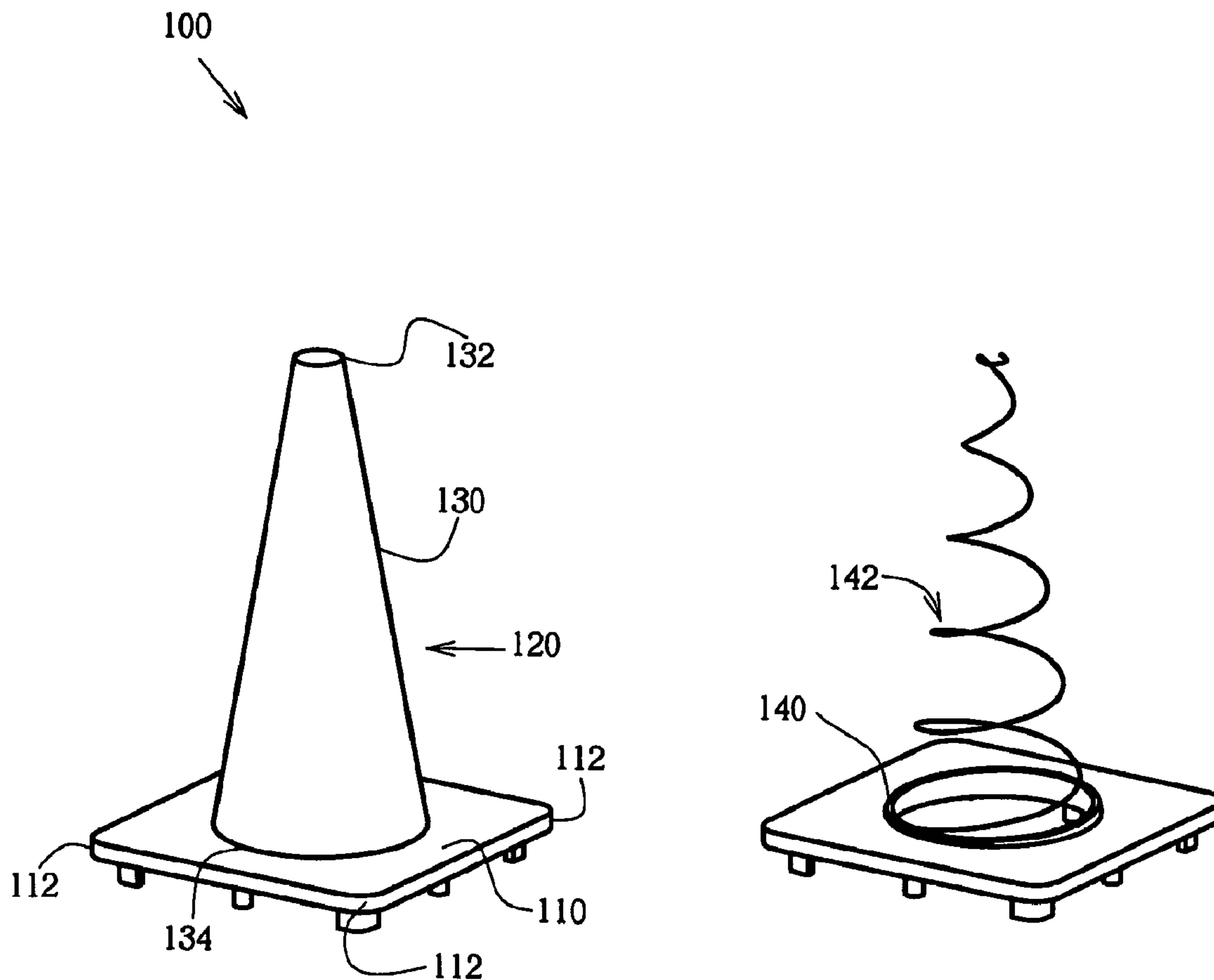

(86) Date de dépôt PCT/PCT Filing Date: 2003/01/23  
 (87) Date publication PCT/PCT Publication Date: 2003/07/31  
 (45) Date de délivrance/Issue Date: 2010/03/23  
 (85) Entrée phase nationale/National Entry: 2004/07/16  
 (86) N° demande PCT/PCT Application No.: US 2003/002116  
 (87) N° publication PCT/PCT Publication No.: 2003/063108  
 (30) Priorités/Priorities: 2002/01/23 (US60/351,557);  
 2002/02/22 (US60/360,141); 2002/04/23 (US10/131,316)

(51) Cl.Int./Int.Cl. *E01F 9/012* (2006.01),  
*E01F 9/017* (2006.01)  
 (72) Inventeur/Inventor:  
 GARCIA, GUADALUPE C., US  
 (73) Propriétaires/Owners:  
 WORLDWIDE SAFETY, LLC, US;  
 TTB PRODUCTS, INC., US;  
 TRAFFIX DEVICES, INC., US  
 (74) Agent: BERESKIN & PARR LLP/S.E.N.C.R.L.,S.R.L.

(54) Titre : DISPOSITIF DE SIGNALISATION FLEXIBLE  
 (54) Title: A FLEXIBLE MARKER DEVICE



(57) Abrégé/Abstract:

A new marker device (100) is provided for increased safety due to a flexible design. The marker device (100) includes a base (110) and a flexible means (142) that is positioned over the base (110). The bottom part (140) of the flexible means is attached to the

(57) **Abrégé(suite)/Abstract(continued):**

base (110). The flexible means (142) maintains in an original position in absence of a natural or traffic perturbation. However, flexible means (142) deviates from this original position in presence of a natural or traffic perturbation. Moreover, the flexible means (142) restores from this deviated position back to the original position after the perturbation disappears or is removed. Furthermore, the marker device (1001) includes a cover (130) to cover the flexible means (142).

## (12) INTERNATIONAL APPLICATION PUBLISHED UNDER THE PATENT COOPERATION TREATY (PCT)

(19) World Intellectual Property Organization  
International Bureau



(43) International Publication Date  
31 July 2003 (31.07.2003)

PCT

(10) International Publication Number  
WO 03/063108 A3

- (51) International Patent Classification<sup>7</sup>: E01F 9/012
- (21) International Application Number: PCT/US03/02116
- (22) International Filing Date: 23 January 2003 (23.01.2003)
- (25) Filing Language: English
- (26) Publication Language: English
- (30) Priority Data:  
60/351,557 23 January 2002 (23.01.2002) US  
60/360,141 22 February 2002 (22.02.2002) US  
10/131,316 23 April 2002 (23.04.2002) US
- (71) Applicant: WORLDWIDE SAFETY, LLC [US/US];  
648 46th Street, Sacramento, CA 95819 (US).
- (72) Inventor: GARCIA, Guadalupe, C.; 4336 Peninsula  
Drive, Modesto, CA 95356 (US).
- (74) Agents: ALBOSZTA, Marek. et al.; Lumen Intellectual  
Property Services, Inc., 2345 Yale Street, Suite 200, Palo  
Alto, CA 94306 (US).
- (81) Designated States (*national*): AE, AG, AL, AM, AT, AU, AZ, BA, BB, BG, BR, BY, BZ, CA, CH, CN, CO, CR, CU, CZ, DE, DK, DM, DZ, EC, EE, ES, FI, GB, GD, GE, GH, GM, HR, HU, ID, IL, IN, IS, JP, KE, KG, KP, KR, KZ, LC, LK, LR, LS, LT, LU, LV, MA, MD, MG, MK, MN, MW, MX, MZ, NO, NZ, OM, PH, PL, PT, RO, RU, SD, SE, SG, SK, SL, TJ, TM, TN, TR, TT, TZ, UA, UG, UZ, VN, YU, ZA, ZM, ZW.
- (84) Designated States (*regional*): ARIPO patent (GH, GM, KE, LS, MW, MZ, SD, SL, SZ, TZ, UG, ZM, ZW), Eurasian patent (AM, AZ, BY, KG, KZ, MD, RU, TJ, TM), European patent (AT, BE, BG, CH, CY, CZ, DE, DK, EE, ES, FI, FR, GB, GR, HU, IE, IT, LU, MC, NL, PT, SE, SI, SK, TR), OAPI patent (BF, BJ, CF, CG, CI, CM, GA, GN, GQ, GW, ML, MR, NE, SN, TD, TG).
- Published:  
— with international search report
- (88) Date of publication of the international search report:  
6 November 2003
- For two-letter codes and other abbreviations, refer to the "Guidance Notes on Codes and Abbreviations" appearing at the beginning of each regular issue of the PCT Gazette.

(54) Title: A FLEXIBLE MARKER DEVICE

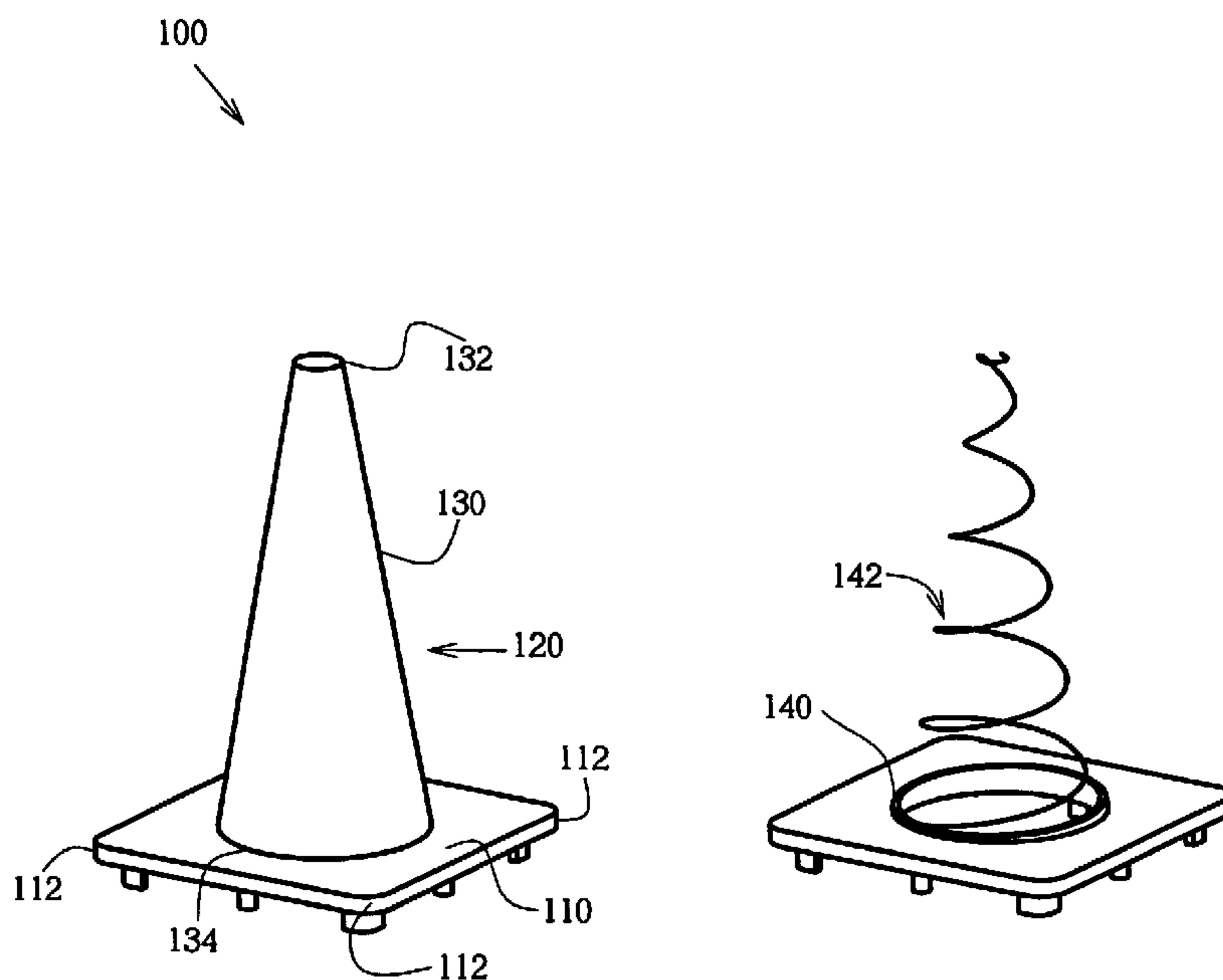

(57) Abstract: A new marker device (100) is provided for increased safety due to a flexible design. The marker device (100) includes a base (110) and a flexible means (142) that is positioned over the base (110). The bottom part (140) of the flexible means is attached to the base (110). The flexible means (142) maintains in an original position in absence of a natural or traffic perturbation. However, flexible means (142) deviates from this original position in presence of a natural or traffic perturbation. Moreover, the flexible means (142) restores from this deviated position back to the original position after the perturbation disappears or is removed. Furthermore, the marker device (1001) includes a cover (130) to cover the flexible means (142).



WO 03/063108 A3

## A FLEXIBLE MARKER DEVICE

### FIELD OF THE INVENTION

5 The present invention relates generally to traffic marker devices or safety cones that are used to alert or divert vehicles, watercrafts, aircrafts and pedestrians to pass safely around hazards, obstacles or other areas. More particularly, the present invention relates to a flexible safety marker device, which self-positions to its original position, deviates from its original position due to natural or traffic perturbations, and restores to its original position  
10 from a deviated position in case such perturbations disappear or are removed.

### BACKGROUND

Traffic or safety cones, are routinely used to direct motorists and pedestrians away from obstacles or dangerous area. These cones are usually brightly colored, hollow conical  
15 shaped devices made of a synthetic, rubber or other plastic (See for example Patent No. 2,333,273 to Scanlon et al.). Traffic and safety cones are meant to minimize damage to persons or vehicles which may collide with the cones. However, safety cones are still of significant danger to the public. One reason is that, although the traffic cones are made out of a synthetic, rubber or other plastic, they are still relatively rigid and tend to fall over  
20 easily when the cones are subject to natural or traffic wind, perturbations by passing traffic or violence. Furthermore, safety cones that are, for instance, run over or hit by a vehicle, could become dangerous objects or obstacles by being airborne or simply laying on the road, in particular to following traffic or surrounding people.

A variety of different self-righting traffic cones have been proposed. For instance, Patent No. 3,386,409 to Dietz Company describes to shape the base of the cone in such a manner that the cone is nestable or stackable self-righting in the manner of a self-righting top. The objective of Patent No. 3,386,409 is to provide a nestable cone which, when it has been  
5 toppled over, will not roll away but will right itself and stand erect near to the position in which it was originally placed. This was accomplished by a hollow molded plastic traffic cone that has a base portion weighted to give a low center of gravity to the cone. The annular bottom of the base is gradually curved outward and upward to provide rockers so the cone is self-righting and is divided into six angularly spaced triangular legs to prevent  
10 rolling when the cone is knocked over.

Patent No. 5,888,016 to Eui Sig Ahn et al. describes a traffic collar cone that has a delineator having a reflection sheet attached on its upper part. A plug is placed under the sheet having an  
15 air inlet and outlet extending upwardly and downwardly there-through. A conical body member is provided, having in its upper end wall an insertion hole in which the plug is mounted. A support panel is provided at the bottom of the body and cone collars are attached on the outer surface of the body member, with vertical spacing between them. The traffic collar cone is made of flexible material and designed to recover its original shape  
20 after being impacted, so that injury to collar cone is eliminated or minimized.

Patent No. 5,993,105 to Chan describes a safety marker that includes a hollow frusto-conical body and a base having a bowl-shaped main portion and a resiliently flexible skirt for yieldably stabilizing the marker against tipping relative to a supportive surface.

So far the solutions have focused on self-righting of the traffic cone. However, these solutions are still not satisfactory from a safety standpoint since they still are either too rigid or can still relatively easy fall over. Accordingly, there is a need to develop a better traffic cone or marker device that further improves road and traffic safety.

### SUMMARY OF THE INVENTION

The present invention provides a new marker device for increased safety due to a flexible design. The marker device of the present invention includes a base and a flexible means that is positioned over the base. The bottom part of the flexible means is attached to the base. The flexible means is, for instance, but not limited to, a coil and maintains in an original position in absence of a natural or traffic perturbation. However, flexible means deviates from this original position in presence of a natural or traffic perturbation. Moreover, the flexible means restores from this deviated position back to the original position after the perturbation disappears or is removed. Furthermore, the marker device of the present invention includes a cover to cover the flexible means. The outside of the cover could include one or more bands of reflective material. In addition, the present invention could include one or more light sources to illuminate the marker device. The light source(s) could be placed inside and/or outside the cover and/or attached to the flexible means and/or the base.

20

In view of that which is stated above, it is the objective of the present invention to provide a flexible marker device or cone to improve safety.

It is still another objective of the present invention to provide a marker device with a flexible means that positions itself to an original position.

5 It is still another objective of the present invention to provide a marker device with a flexible means that deviates from its original position to a new position and wherein the deviation is dependent on the type of perturbation.

10 It is still another objective of the present invention to provide a marker device with a flexible means that restores from the deviated position back to its original position, whereby the restoring mechanism is an inherent property of the flexible means.

It is yet another objective of the present invention to provide a marker device with a base that has a significantly less likelihood to fall over as a result of a perturbation.

15 It is yet another objective of the present invention to provide a marker device with a low center of gravity close to its supporting surface or ground.

20 It is yet another objective of the present invention to provide a marker device with a cover that includes reflective material.

It is yet another objective of the present invention to provide a marker device with a light source to illuminate the marker device.

The advantage of the present invention over previous devices is that the present marker device can more easily resist various types of perturbations without falling over. Yet another advantage is that the marker device of the present invention significantly reduces the damage to persons or vehicles. These advantages are accomplished by a marker device  
5 with a base that remains on the ground and a flexible part that deviates from its original position due to a perturbation in any direction and in any type of way irrespective of the type of perturbation.

### BRIEF DESCRIPTION OF THE FIGURES

10 The objectives and advantages of the present invention will be understood by reading the following detailed description in conjunction with the drawings, in which:

**FIG. 1** shows an exemplary embodiment of a marker device according to the present invention;

15 **FIG. 2** shows an example of a top view of a marker device according to the present invention;

**FIGS. 3-4** show exemplary embodiments of the flexibility of a marker device according to the present invention;

**FIG. 5** shows an example of a position of a marker device due to a perturbation according to the present invention;

20 **FIG. 6** shows an example of a marker device when a marker device is hit or run over by a car according to the present invention;

**FIG. 7** shows an example of a light source inside of a marker device according to the present invention;

- FIG. 8** shows an example of a marker device with one rod as flexible means according to the present invention;
- FIG. 9** shows an example of a position of the marker device shown in **FIG. 8** due to a perturbation according to the present invention;
- 5 **FIG. 10** shows an example of a marker device with three rods as flexible means according to the present invention;
- FIG. 11** shows an example of a position of the marker device shown in **FIG. 10** due to a perturbation according to the present invention;
- FIG. 12** shows an example of a cover with reflective material according to the present  
10 invention;
- FIG. 13** shows a cross section view of an exemplary marker device assembly according to the present invention;
- FIG. 14** shows an example of a rod with a spring to enhance the flexibility of the rod, i.e. flexible means, according to the present invention; and
- 15 **FIG. 15** shows an example of a marker device with two or more flexible means according to the present invention.

## DETAILED DESCRIPTION OF THE INVENTION

Although the following detailed description contains many specifics for the purposes of  
20 illustration, anyone of ordinary skill in the art will readily appreciate that many variations and alterations to the following exemplary details are within the scope of the invention. Accordingly, the following preferred embodiment of the invention is set forth without any loss of generality to, and without imposing limitations upon, the claimed invention.

The marker device of the present invention could be used to alert or divert vehicles, watercrafts, aircrafts and pedestrians to pass safely around hazards, obstacles or other areas.

However, the marker device of the present invention is not limited to any particular use and could also be used for recreational or sporting events. Furthermore, the marker device is

5 usually recognized as a cone and is therefore called safety cone. However, the marker device of the present invention is not limited to any particular shape and could also be straight, curved, circular, cylindrical, square or any type of shape that is needed or required to alert or divert someone, or mark-off a particular space or area. Therefore, the device of the present invention is referred to as a marker device. Furthermore, there is also no  
10 restriction to the size of the particular marker device or safety cone of the present invention.

**FIG. 1** shows an exemplary embodiment of the marker device **100** according to the present invention. Marker device **100** includes a base **110** and a cone **120**. Base **100** provides the support of marker device **100** and keeps the marker device on the ground or surface. Base  
15 **110** is shown as a square with round edges **112**. However, base **110** could take any type of shape and could also be made out of any material as long as it provides the required support. The measurement (length and width) of base **110** could be, but is not limited to, about 14" by about 14", which is the standard base size for conventional safety cones in the U.S.A. (e.g. 18" and 28" high cones). Cone **120** includes a flexible cover **130** that covers a  
20 flexible means **140**. Preferably, cover **130** is made out of a flexible material that allows cone **120** to easily flex, bend or fold. Cover **130** should not resist, or at least have minimal resistance to, any movement of flexible means **140**. The top **132** and bottom **134** of cover **130** could be attached to flexible means **140**. Instead of attaching bottom **134** of cover **130** to flexible means **140**, bottom **134** could be attached to base **110**. The type of means for

connecting cover **130** is, for instance, but not limited to, stitches, clamp(s), glue, Velcro, a ring (See **FIG. 13**) or the like. However, cover **130** could also fit tight over flexible means **140** and in this case there is no need for a connecting means to connect cover **130**.

5 **FIG. 1** shows cone **120** in a cone shape. However, as discussed above, cone **120** could take any type of shape and the shape is mostly dependent on the type of marked device. Cone **120** could, for instance, be shaped as an inverted cone, a cylindrical marker, a circular marker, a square marker, a hexagonal, a tubular marker or any three-dimensional shape type marker.

10

**FIG. 2** shows a top view of base **110**. In some embodiments, base **110** provides a circular opening **200**, however, such an opening is not necessary. Opening **200** is, however, preferred so that the marker devices of the present invention can be stacked as is common in the prior art. **FIG. 2** also shows a top view of flexible means **140** without cover. The  
15 bottom part **142** of flexible means **140** is attached to base **110**, preferably centered over base **110**. In case base **110** has opening **200**, flexible means **140** is attached close to the edge **210** of opening **200**, either at the inside of opening **200** or at the top of base **110**.

Flexible means **140** is, for instance, a coil that is shaped as a cone when marker device **100**  
20 is meant to be safety cone. Flexible means **140** provides for the flexibility of marker device **100**. The key idea of the present invention is that the base remains on the ground or surface, and the flexible means is in either its original position or a deviated position from the original position. Flexible means **140** flexes, bends or folds to any direction as shown in **FIGS. 3-4** and could, for instance, bend sideways, downward or even flex/extend

upward. In other words, flexible means deviates from its original position (i.e. natural or neutral position in case flexible means is a coil or a spring). The direction and amount of deviation from the original position depends on the type of perturbation force (i.e. the amount and direction of the perturbation force at the marker device). Once the perturbation is removed or disappears, flexible means restores from the deviated position to its original position. The present invention is not limited to an indirect or direct contact or perturbation. Examples of different types of perturbations are, for instance, but not limited to, natural wind (indirect), traffic wind (indirect), perturbations from passing traffic (indirect and/or direct) kicking (direct), pushing (sideways, upwards and/or downwards, direct), violence (indirect and/or direct) or the like.

**FIG. 5** shows marker device **500** subject to an indirect or direct perturbation force **510** that makes flexible means (not visible in **FIG. 5** since it is covered by the cover) flex, bend or fold away from its original (upright) position as it is shown in **FIG. 1**. Consequently and due to the flexible material of the cone, cone **520** flexes, folds or bends according to the new position of flexible means as a result of perturbation force **510**. **FIG. 6** shows a situation where a car **600** runs into and over a marker device of the present invention, i.e. direct perturbation force. When car **600** hits marker device **610** with bumper **620**, base **630** remains on the ground and only the flexible means and cover bend as indicated by **640**. In the example of **640**, the impact between the car and flexible means causes the original position of the flexible means (see e.g. **FIG. 1**) to change to a deviated position **640**. To sustain such a deviation, the flexible means has an impulse response to the direct perturbation force as shown in **FIG. 6**. When marker device **650** is under the car, base **630** again remains on the ground and only the flexible means and cover bend as indicated by **660**. The marker device re-positions itself to the original (upright) position when the car is no longer on top of the marker device as indicated by **670**. During the perturbation, the base of the marker device of the present invention might undergo some rocking motion(s), however, once the perturbation disappear the base of the maker device will return to its original and stable position. Another example (not shown) is that the

marker device of the present invention could be dropped down to the ground (which results in an indirect perturbation to the flexible means), for instance, but not limited to, from a car or a truck that is delivering several marker devices to an area to, for instance, block an obstacle. After landing on the ground, the marker devices of the present invention might initially rock but will come to their original and stable position once the rocking motions oscillate out. The impact of the landing of the marker device on the ground also causes sudden perturbations to the flexible means. However, as discussed *supra*, these perturbations do not disturb the stability of the marker device due to the fact that flexible means has the ability to deviate from one position to another in response to the perturbation force that acts on the flexible means (i.e. the flexible means has an impulse response to the perturbation force(s)). The likelihood that the marker device of the present invention remains in that position is also facilitated by the marker device of the present invention having a very low center of gravity (close to the ground or supporting surface). The low center of gravity is mainly due to a relatively heavier base compared to the combined weight of the flexible means and cover that over positioned over the base (flexible means and cover are preferably made of lightweight material(s)). The center of gravity of the marker device could virtually be close to the top of the base or somewhere in the base in case the difference between the weight of the base and combined weight of the flexible means and cover that are positioned over the base is large as a person of average skill would readily appreciate. Furthermore, the fact that the flexible means (and cover) bends due to perturbation(s), significantly reduces the torque that the perturbed flexible means produces onto the base (this in contrast to existing traffic safety cones or marker devices which have a relatively stiff top/cone part). The reduced torque improves the stability of the base and therewith the stability of the marker device of the present invention.

Important to note is that despite any type of perturbation, the base of the marker device remains on the ground or surface and it is the flexible means and cover that deviates from the original position to a new position depending on the perturbation force. In addition, when the perturbation is removed, the flexible means and cover re-positions itself to its original position. However, it would be possible that as a result of a perturbation the base

initially starts to rock, however, the rocking of the base will oscillate out and the base will come back to its original stable position on the ground or surface. In practice, though note this is not directly necessary, safety cones or marker devices could also be glued to the ground or surface which makes the advantages of the present invention even clearer since  
5 the flexible cone (i.e. flexible means and cover) then easily deviates from its original position in a safe manner and the base remains on the ground. The base could therefore include a securing means to temporarily secure the base to a surface or ground. Examples of securing means could be glue, nail(s), screw(s), hook(s), spike(s), anchor(s), or the like.

10 Furthermore, the marker device of the present invention could include one or more light sources such as light source **710** shown in marker device **700** in **FIG. 7**. Light source **710** could be positioned anywhere inside cover **720** to illuminate the inside of cover **720**. However, light source **710** could also be positioned to the base or flexible means. In case a light source is included inside cover **710**, it would be preferred that the material of the  
15 cover is transparent to light so that the marker device becomes visible in the dark or in situations of poor visibility. Light source **710** could be any type of light source and is not limited to a particular type or mechanism. Light source **710** is preferably lightweight and small. Light source **710** could be positioned by or near opening **200** of base **110**, but could also be positioned near the top **730** of the flexible means **740**. In general, the light  
20 source(s) could be placed at the base, flexible means or cover (inside or outside). The marker device of the present invention could also have a sensor to turn on the light source. The sensor could, for instance, be positioned at the bottom of the base. Once the marker device is placed on the ground or surface, the sensor turns on the light source and the marker device becomes lit. The sensor could, for instance, be a mechanical switch.

However, the sensor is not limited to a mechanical switch since it could also be a light-sensitive sensor that turns on the light source depending on whether it is, for instance, daytime or nighttime. In addition, the sensitivity of the sensor can also be set so that it will be turned on when the visibility becomes less.

5

The present invention has now been described in accordance with several exemplary embodiments, which are intended to be illustrative in all aspects, rather than restrictive. Thus, the present invention is capable of many variations in detailed implementation, which may be derived from the description contained herein by a person of ordinary skill in the art. For instance, in order to meet the stated (explicit or implied) objectives and advantages of the present invention, the marker device and its components could be designed, manufactured and assembled in a variety of different ways with a variety of compatible different of materials and dimensions. The discussion *infra* provides some examples of the different materials, dimensions as well as possible assemblies and variations.

15

Generally speaking, the height of the marker device of the present invention is not restricted. However, the art as well as Government (Federal, State/Province or Local) regulations teach several specific dimensions/heights for safety traffic cones. Examples of such dimensions in the U.S.A. are, for instance, but not limited to, a 14-inch high cone, 18-inch high cone, 28-inch high cone or a 36-inch high cone. As a person of average skill in the art would readily appreciate, the height of the marker device is mostly dependent on the type of use or application as well as on any type of Government regulations or requirements (Federal, State/Province or Local), which (may) vary in different countries/parts around the World.

20

The base of the marker device plays an important role in the stability of the marker device. As it is discussed *supra*, the weight of the base should be significantly larger than the combined weight of all the components that are positioned above the base.

Furthermore, the dimensions of the base should be large enough to support, in a stable fashion, the entire marker device with or without perturbations. Again, the art as well as e.g. U.S. Government regulations teach several specific dimensions for the base of the marker device (e.g. about 14" by about 14", which is the standard base size for conventional safety cones (e.g. 18" and 28" high cones). The materials that could be used for the base are, for instance, but not limited to, rubber, soft/hard plastic, PVC, any type of wood including bamboo or wood compositions, metal, or the like.

The flexible means could be any type of flexible material and is also not limited to a coil as long as the material provides the necessary flexibility to meet the objectives and advantages of the present invention as discussed *supra*. As a person of average skill in the art would readily appreciate, the physical dimensions of the flexible means determine the behavior of the flexible means, such as, for instance the type of material (therewith the elasticity of the material), the shape and dimensions of the material (e.g. a 36" spiral cone shape with a certain number of spirals) and the diameter of the material. Examples of a type of material for the flexible means are, for example, but not limited to, a metal (e.g. aluminum, steel, etc.), a carbon, a graphite, a wood (including bamboo), a fiberglass, a plastic, a rubber or the like. As a person of average skill in the mechanical engineering art would readily appreciate, there are different ways to determine the physical dimensions of the flexible means.

The process for determining the physical dimensions of the flexible means is usually simplified by some economical constraints and/or regulatory constraints/requirements; i.e. a material might be chosen since it is cheaper and easier to handle in manufacturing, easier to assemble, better recyclable, and/or required by Government standards (Federal, State/Province or Local). In case of a person using a computer model of a marker device or one or more of its components, the person could optimize the simulated marker device or component(s) according to a particular force that simulates a type of perturbation, force range that simulates different types of perturbations, and/or parameters that describe/analyze the linear or angular dynamics of the marker device or its component(s) (e.g. how much deviation is allowed and how quickly does the flexible means return from the perturbed position back to the original position).

The flexible means could also include one or more rods as long as the physical characteristics of the rod(s) meet the objectives and advantages of the present invention as they are discussed *supra*. **FIG. 8** shows an example of a safety cone **800** in which the flexible means is based on one rod **810** that is positioned over base **820**. Rod **810** could, for example, be attached with its bottom end to base **820** and with its top end to the top of cover **830** (e.g. a ring). The cone shape of exemplary safety cones as it is discussed *supra*, is defined and determined predominantly by the flexible means. However, in case of marker device **800**, the cone shape has to be determined by cover **830** that is placed over rod **810**. **FIG. 9** shows safety cone **800** subject to a perturbation **900**, whereby rod **810** is bend due to perturbation **900**. **FIG. 10** shows examples of a safety cone **1000** in which the flexible means is based on three rods **1010**, **1020**, and **1030** that are positioned over base

**1040.** Rods **1010**, **1020**, and **1030** could, for example, be attached with their bottom ends to base **1040** and with their top ends to the top of cover **1050** (e.g. a ring). **FIG. 11** shows safety cone **1000** subject to a perturbation **1100**, whereby rods **1010**, **1020**, and **1030** are bend due to perturbation **1100**.

5

In a preferred embodiment, the cover should have air-passing capabilities to make it less wind resistant. Furthermore, the cover should be lightweight, transparent to light and preferably should not resist, or at least minimize, the movements of the flexible means as discussed *supra*. Examples of such a material are for instance, but not limited to, a mesh type material, a vinyl, a canvas, a polyester, or the like. Furthermore, the outside of the cover could include all kinds of shapes and/or reflective material. Preferred shapes (reflective collar(s), stripes, or other types of regulatory shapes or signs) are the ones recommended by the Government (Federal, State/Province or Local; e.g. the U.S. Department of Transportation including the FAA and/or the Federal Highway Administration) and include common traffic control or warning signs. **FIG. 12** shows an example of a cone **1200** with a cover **1210**. Cover **1210** includes two bands of reflective material that are positioned at two distinct positions on cover **1210** according to U.S. Government regulations. **FIG. 12** shows the first reflective band (shaded) positioned at about 3" (inches) from the top of cover **1210** and this first band is about 6" (inches) in height. **FIG. 12** shows the second reflective band (shaded) positioned at about 2" (inches) from the bottom of the first reflective band and this second band is about 4" (inches) in height. Any other type of shape or sign can be included and is depended on the type of application. It is possible to use a reflective material that can be attached/assembled to the cover using heat, glue, tape, Velcro, sewing or the like. An example of such a reflective

10

15

20

material is, for instance, but not limited to, the 3M 8710 reflective material (from the 3M Corp.) that also has the benefit of about 500 candlelight power. As a person of average skill in the art would readily appreciate, the present invention is not limited to 3M 8710 reflective material or to a reflective material with about 500 candlelight power, since any  
5 type of reflective material could be used each with a different amount of reflective intensity (higher or lower), (see e. g. Reflecto-Lite Inc.).

**FIG. 13** shows an example of a marker device assembly **1300** with a base **1310**, a spiral **1320**, a cover **1330** and a ring **1340** using a cross sectional view of marker device assembly  
10 **1300**. Ring **1340** is used as a sort of quick-connector for the modular components (i.e. base **1310**, spiral **1320** and cover **1330**) of the marker device. Note that for clarity purposes in the inset figure, only part of the bottom ring of spiral **1320** is shown and spiral **1320** should in fact extend upward as shown by **1300**. The key idea of ring **1340** is to position spiral **1320** and cover **1330** against the inner edge **1315** of base **1310**. Ring **1340** could be made  
15 out of any type of material (e.g. a plastic, rubber or polyester) as long as it has enough strength to hold together base **1310**, spiral **1320** and cover **1330** as well as enough flexibility to assemble (de-assemble) these three parts together (apart).

**FIG. 14** shows an example of how base **1410** and flexible means could be connected in  
20 case the flexible means includes one or more rods **1420** and **1430**. For example, rod **1420** includes an end part **1422** that could be positioned more or less parallel to the bottom **1415** of base **1410**. Rod **1420** could include a spring **1424** as an integral part of rod **1420** to ensure the necessary flexibility of the flexible means. However, the question whether

spring 1424 is necessary depends on the physical characteristics (e.g. flexibility) of rod 1420.

The present invention is also not limited to a marker device with one flexible means since it could also include two or more flexible means. FIG. 15 shows an exemplary embodiment of a marker device 1500 in the form of a barricade that includes two or more flexible means 1520 and 1530 that are positioned over base 1510. In case of a barricade, base 1510 typically has a rectangular shape. Base 1510 could have opening that could be advantageous for stacking purpose, however, this is not necessary. The two or more flexible means 1520 and 1530 could be positioned to base 1510 in a similar manner as discussed *supra* for a single flexible means. Marker device 1500 could also include: (1) a cover 1540 that covers the two or more flexible means, (2) one or more shapes and/or reflective materials 1550 and 1552, and/or (3) one or more light sources placed on the outside (e.g. 1560 and 1562) of cover 1540 or at the inside of cover 1540 (not shown in FIG. 15, but discussed *supra*). It should be clear to a person of average skill in the art that the teachings for a marker device with one flexible means, as discussed *supra*, also apply to a marker device with two or more flexible means. Furthermore, it should be clear to a person of average skill in the art that a marker with two or more flexible means is not limited to a barricade, since such a marker device could also be a fence-like structure as long as all these variations include the advantages and objective as stated and discussed *supra* in terms of safety, flexibility when subject to direct or indirect perturbations. A fence-like marker device according to the present invention could be small but also significantly wide, for instance to fence-off a yard, a street part etc. Imagine that a car runs into such a wide fence, then the part of the fence where the car runs into flexes, bends etc.

according to the teaching *supra* and restores to its natural original position when the car  
(read perturbation) has disappeared.

All such variations are considered to be within the scope and spirit of the present invention  
5 as defined by the following claims and their legal equivalents.

**What is claimed is:**

1. A safety marker device, comprising:

(a) a base having an opening for stacking with another safety marker device;

5 (b) a flexible means having an impulse response to indirect and direct perturbations caused by a moving vehicle or caused by being dropped from a vehicle, said flexible means is positioned over said base, wherein said base supports said flexible means; and

10 (c) a cover to cover said flexible means, wherein said cover is made of a flexible material and allows said impulse response to said indirect and direct perturbations;

wherein said base being heavier than the combined weight of said flexible means and said cover,

15 wherein said flexible means maintains in an original position in absence of said indirect and direct perturbations, and flexes from said original position to a bent position in presence of any of said indirect and direct perturbations, wherein said bent position is characterized by having part of said flexible means bent up to a substantially horizontal position with respect to said base, and

20 wherein said safety marker device has a low center of gravity mainly due to said heavier base, whereby said low center of gravity facilitates in restoring said original position and whereby said heavier base facilitates said flexing.

2. The device as set forth in claim 1, wherein said flexible means is a coil and said coil is shaped as a cone.

25

3. The device as set forth in claim 1, wherein said base is square.

4. The device as set forth in claim 1, wherein said base further comprises securing means to temporarily secure said base to a surface.

30

5. The device as set forth in claim 1, further comprising a light source.

6. The device as set forth in claim 5, wherein said light source is attached to said base.
- 5 7. The device as set forth in claim 1, wherein said cover comprises a reflective material.
8. A safety cone, comprising:
- 10 (a) a base having opening for stacking with another safety cone;
- (b) a coil having an impulse response to indirect and direct perturbations caused by a moving vehicle or caused by being dropped from a vehicle, said coil has a cone shape and is positioned over said base, wherein said base supports said coil; and
- 15 (c) a cover to cover said coil, wherein said cover is made of a flexible material and allows said impulse response to said indirect and direct perturbations;
- wherein said base being heavier than the combined weight of said coil and said cover,
- wherein said coil maintains in an original position in absence of said indirect and direct perturbations, and flexes from said original position to a bent position in presence of any of said indirect and direct perturbations, wherein said bent position is characterized by having part of said coil bent up to a substantially horizontal position with respect to said base, and
- 20 wherein said safety cone has a low center of gravity mainly due to said heavier base, whereby said low center of gravity facilitates in restoring said original position and whereby said heavier base facilitates said flexing.
- 25
9. The safety cone as set forth in claim 8, wherein said base is square.
- 30 10. The safety cone as set forth in claim 8, wherein said base further comprises securing means to temporarily secure said base to a surface.

11. The safety cone as set forth in claim 8, further comprising a light source.
12. The safety cone as set forth in claim 11, wherein said light source is attached to  
5 said base.
13. The safety cone as set forth in claim 8, wherein said cover comprises a reflective material.

1/13

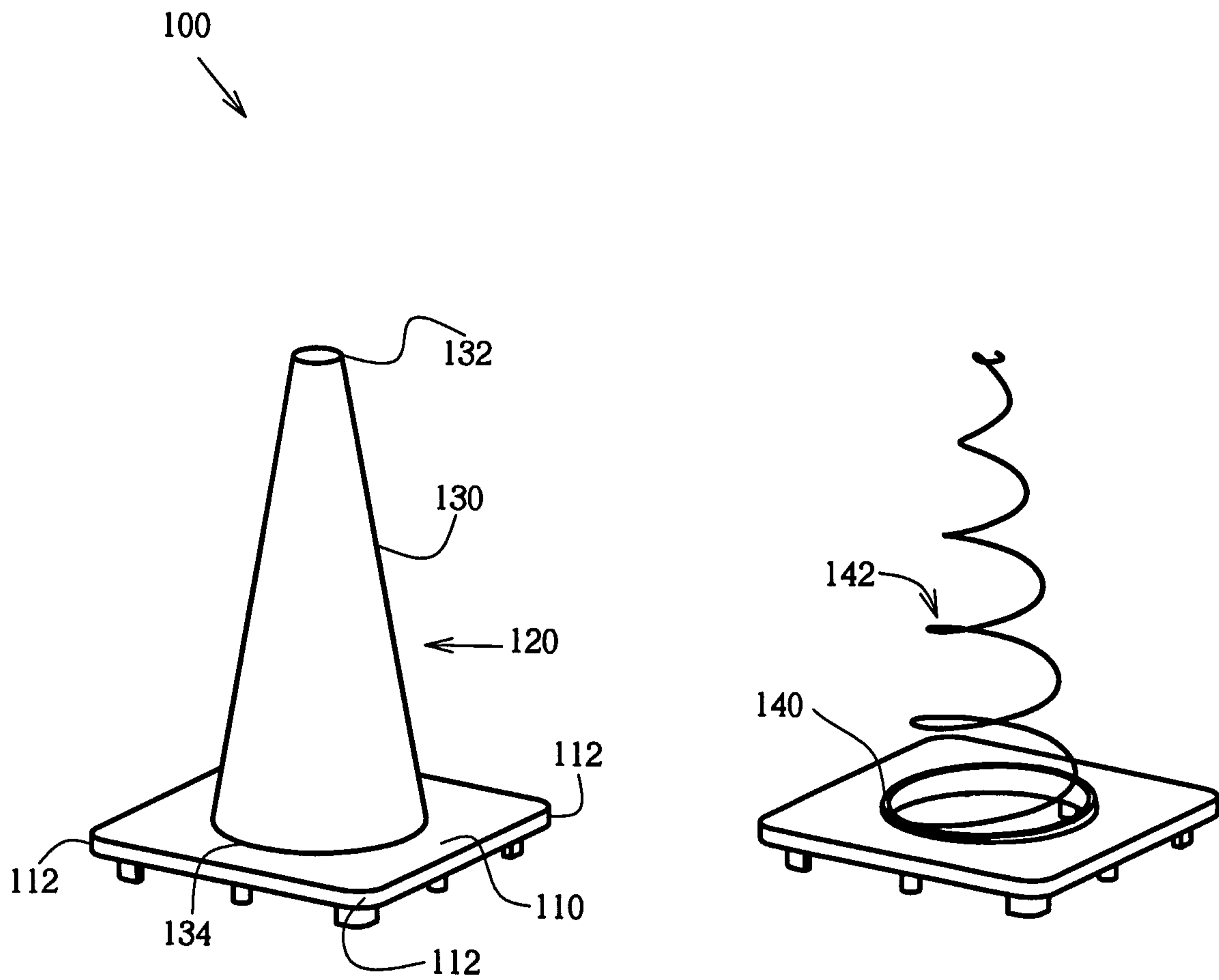

Fig . 1

2/13

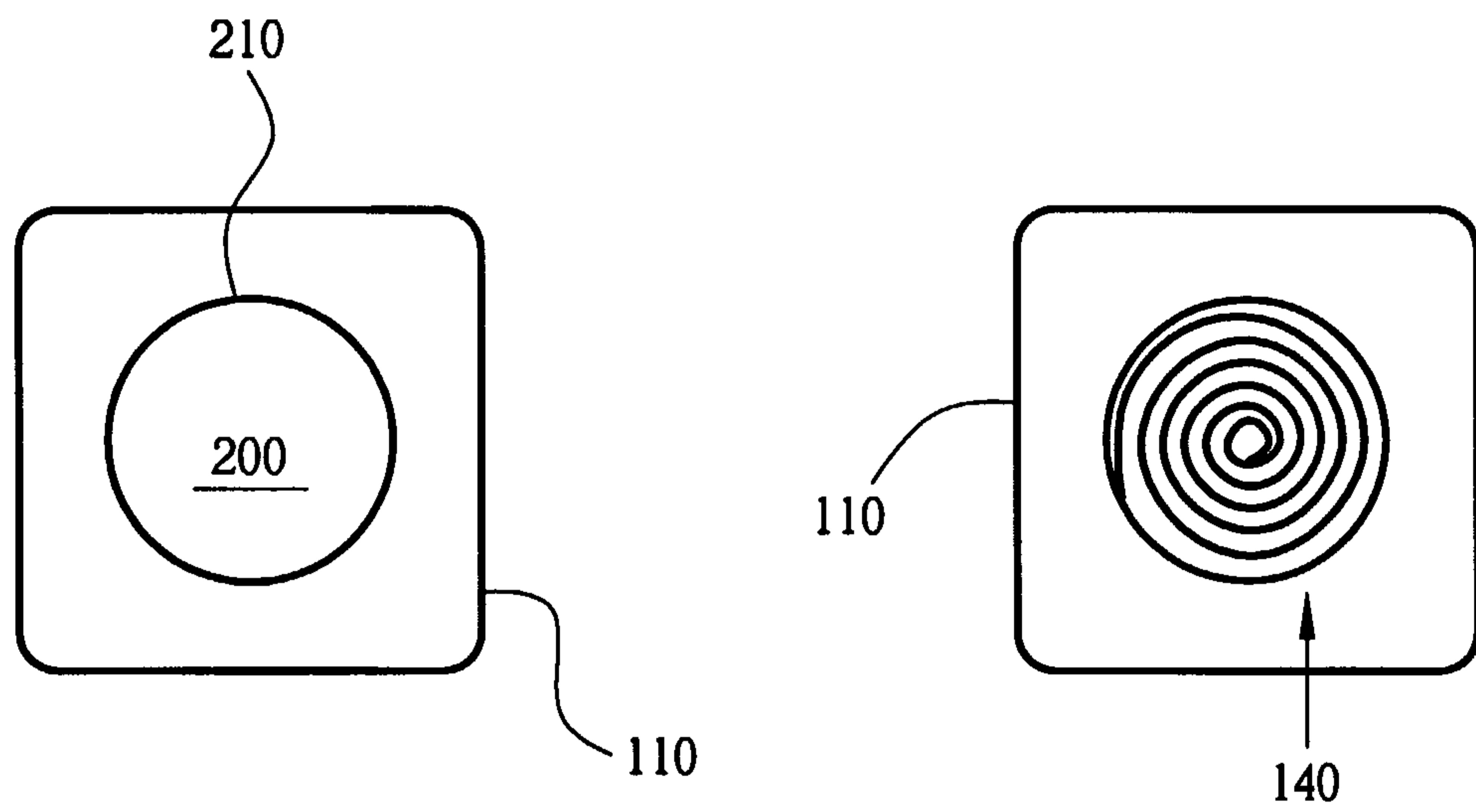

Fig. 2

3/13

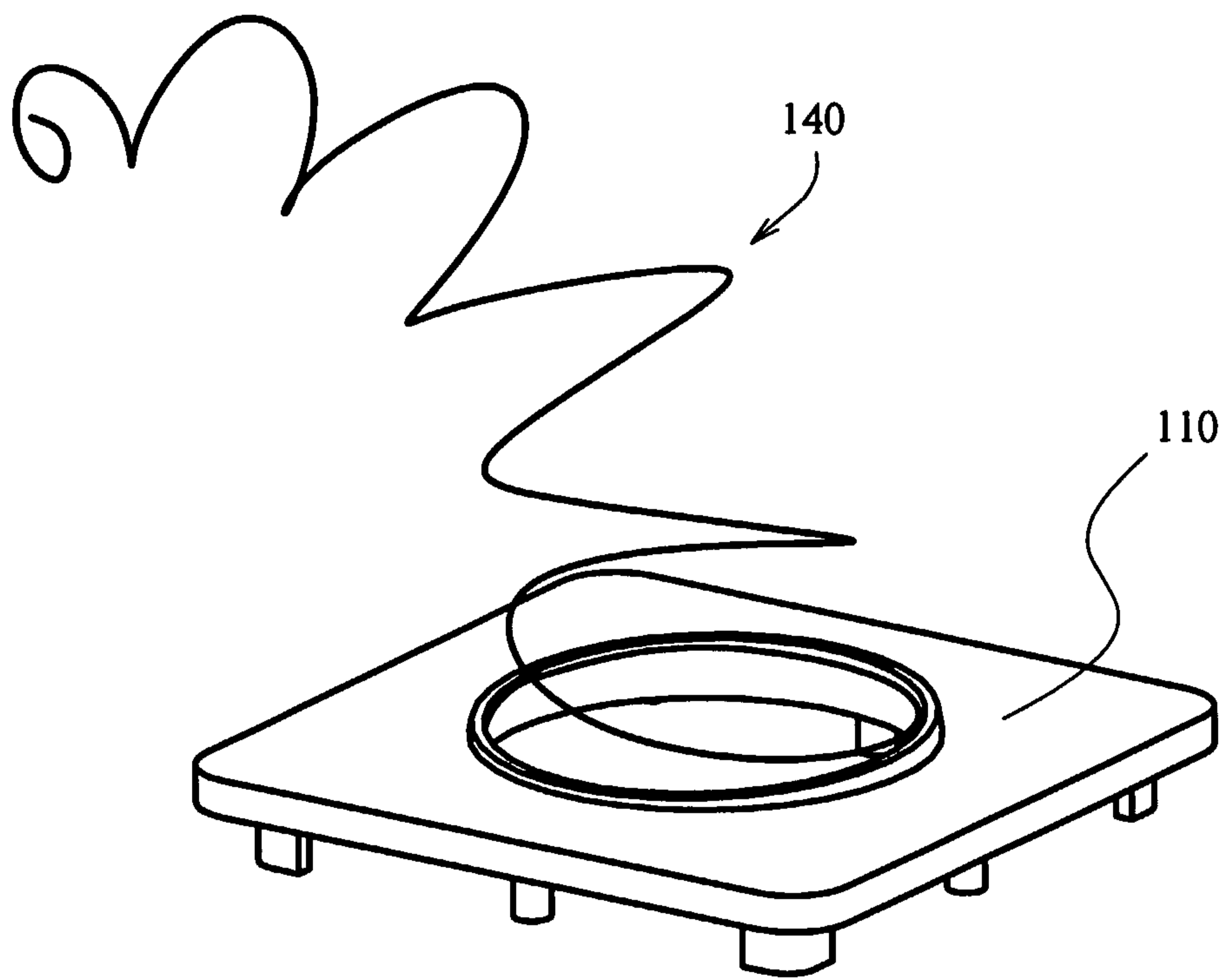

Fig . 3

4/13

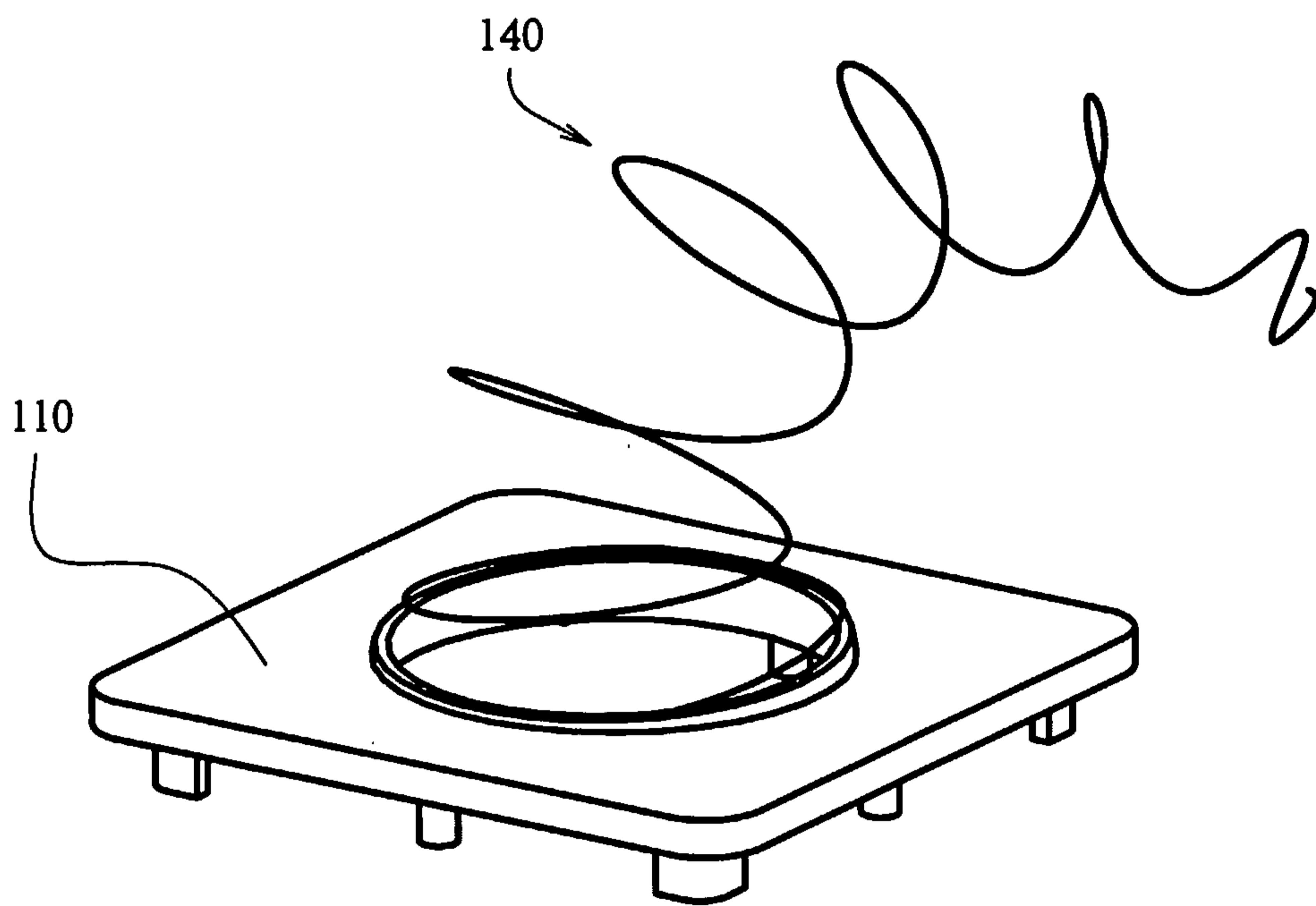

Fig . 4

5/13

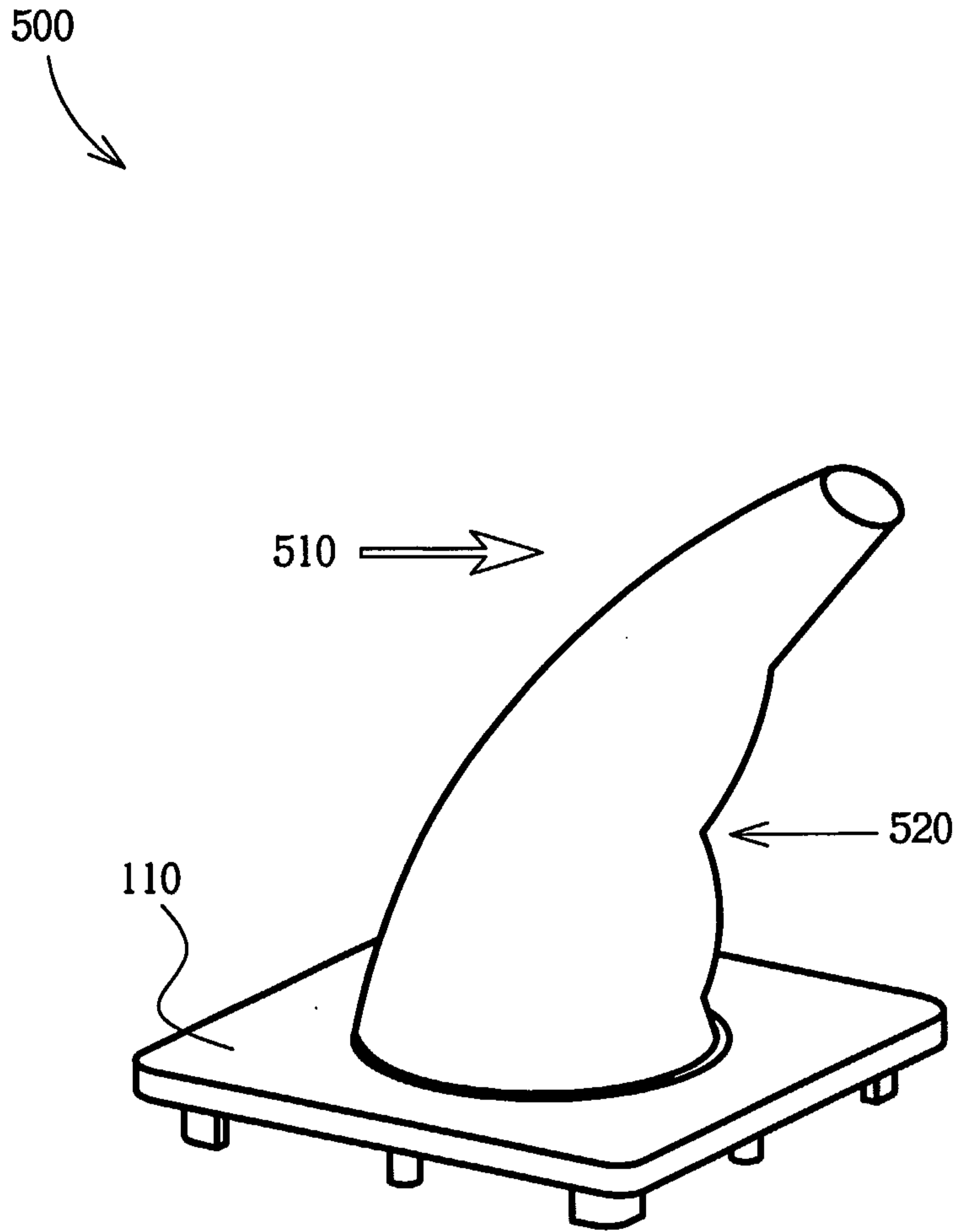

Fig . 5

6/13

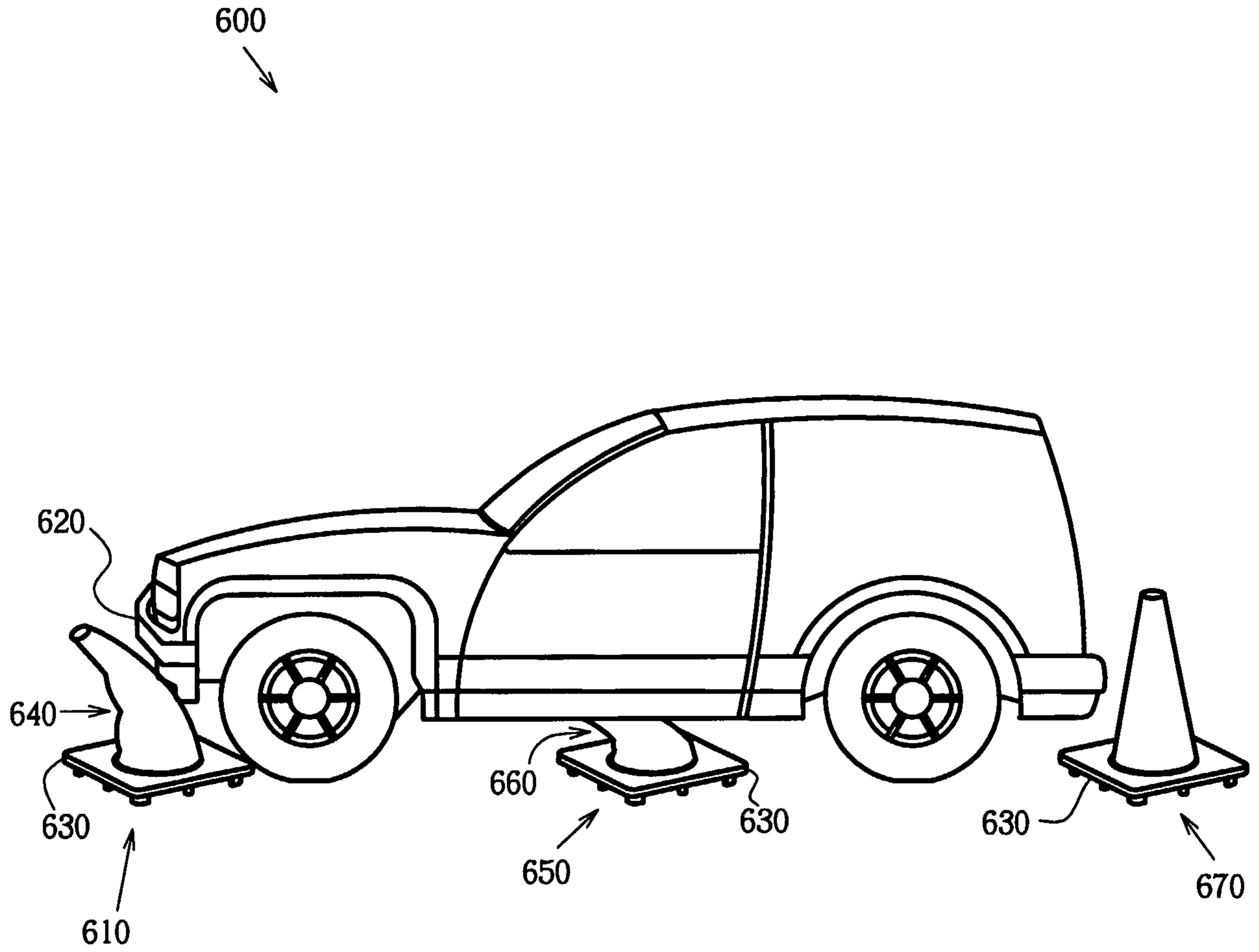

Fig . 6

7/13

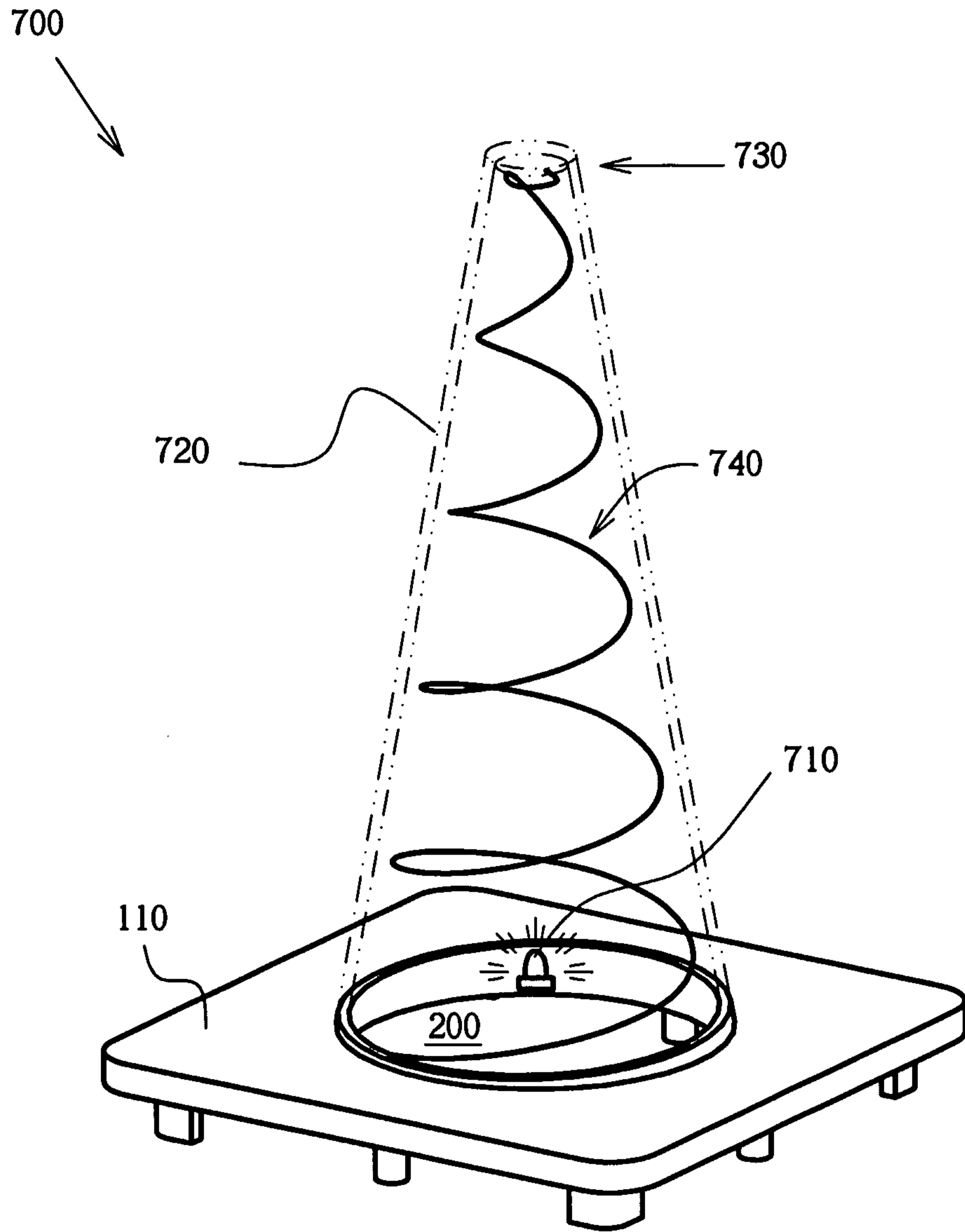
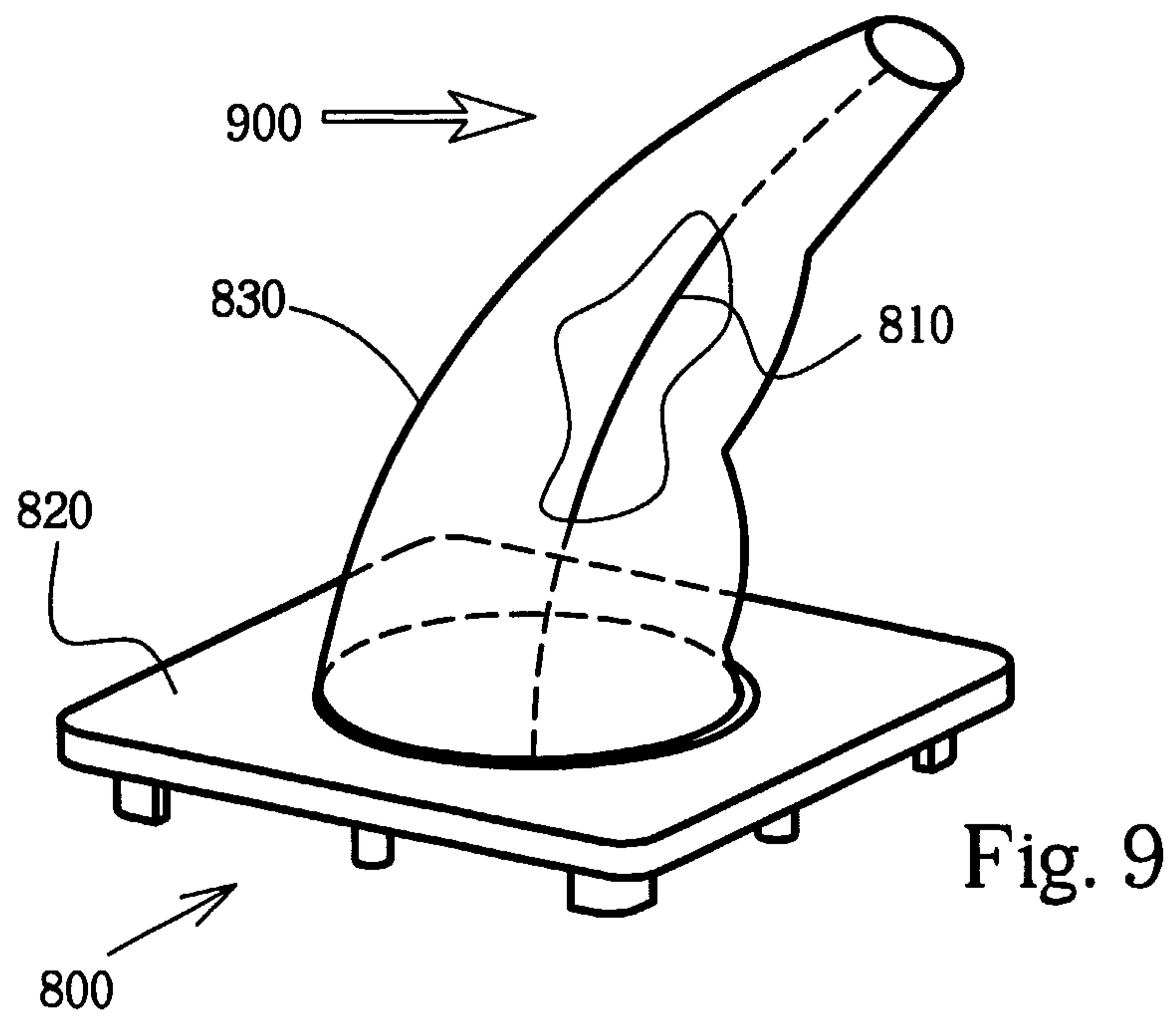
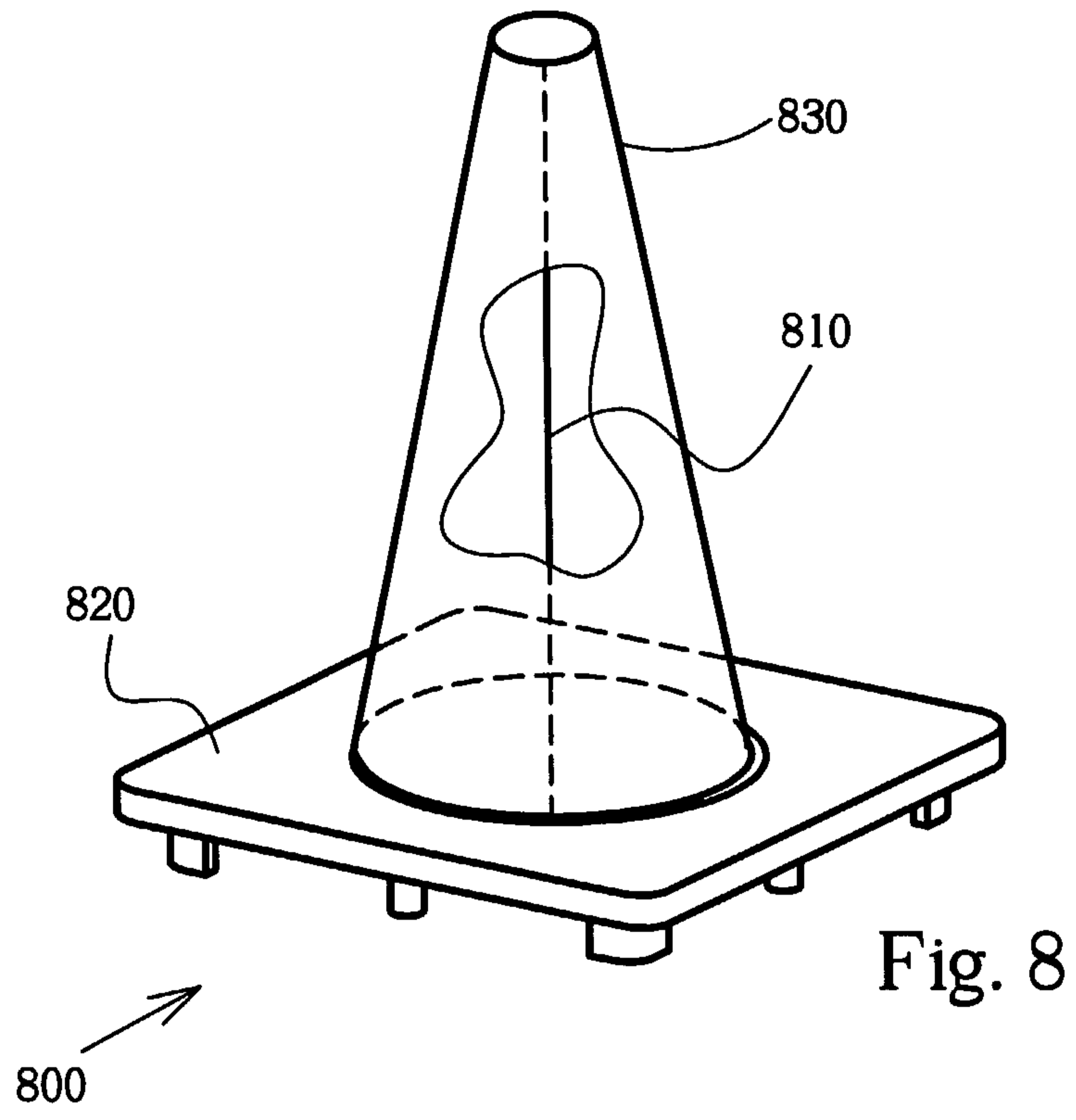
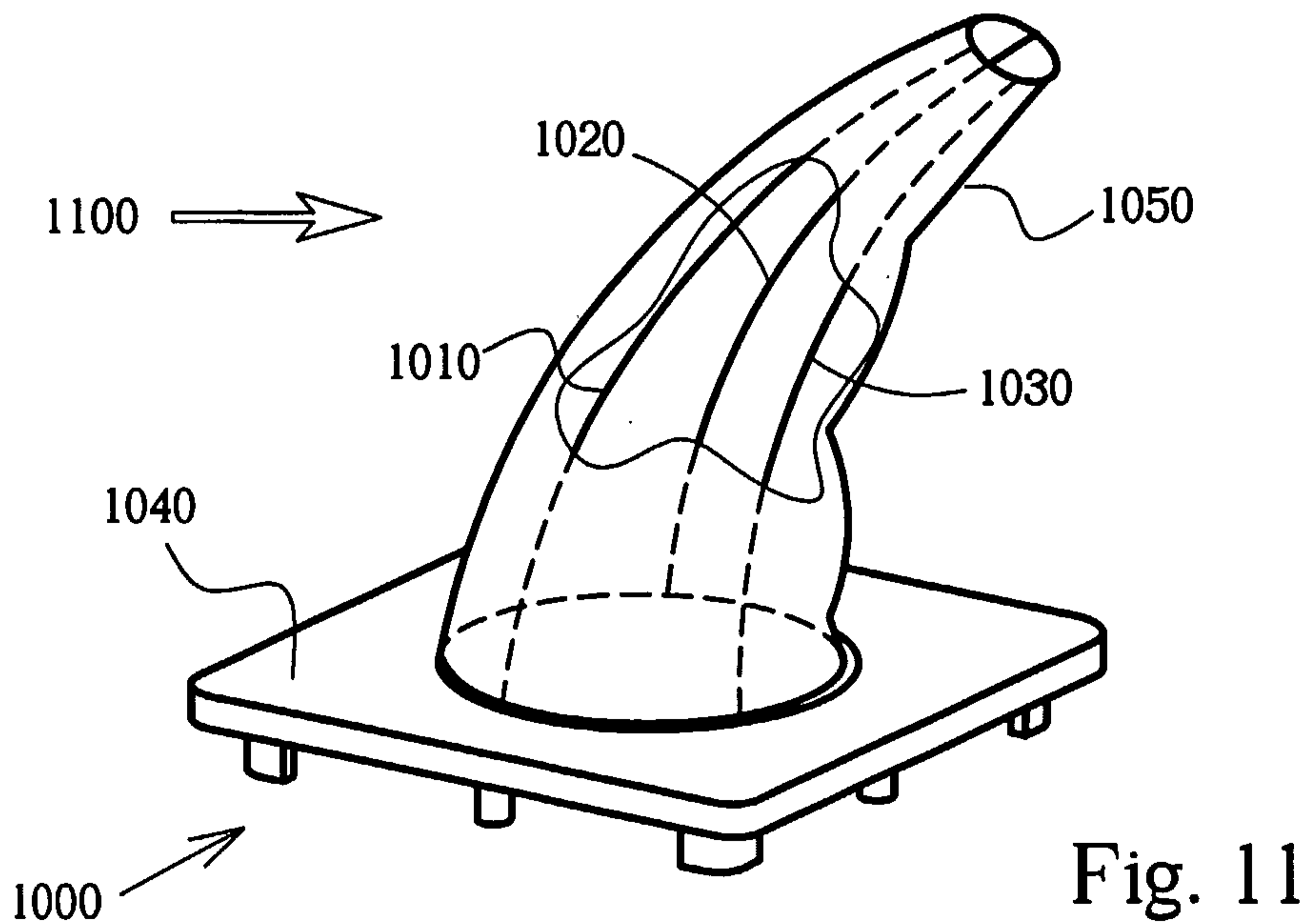
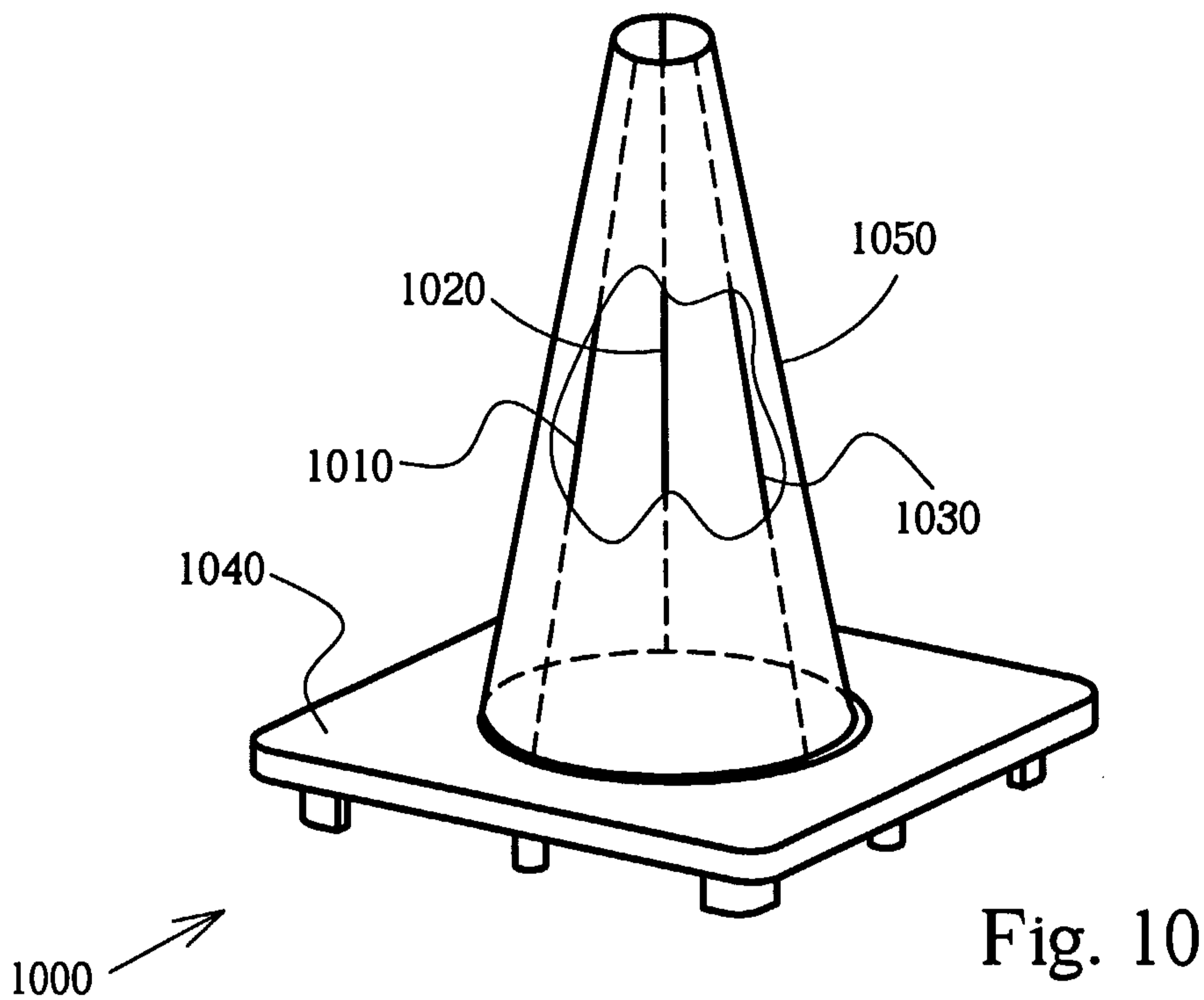

Fig . 7

8/13



9/13



10/13

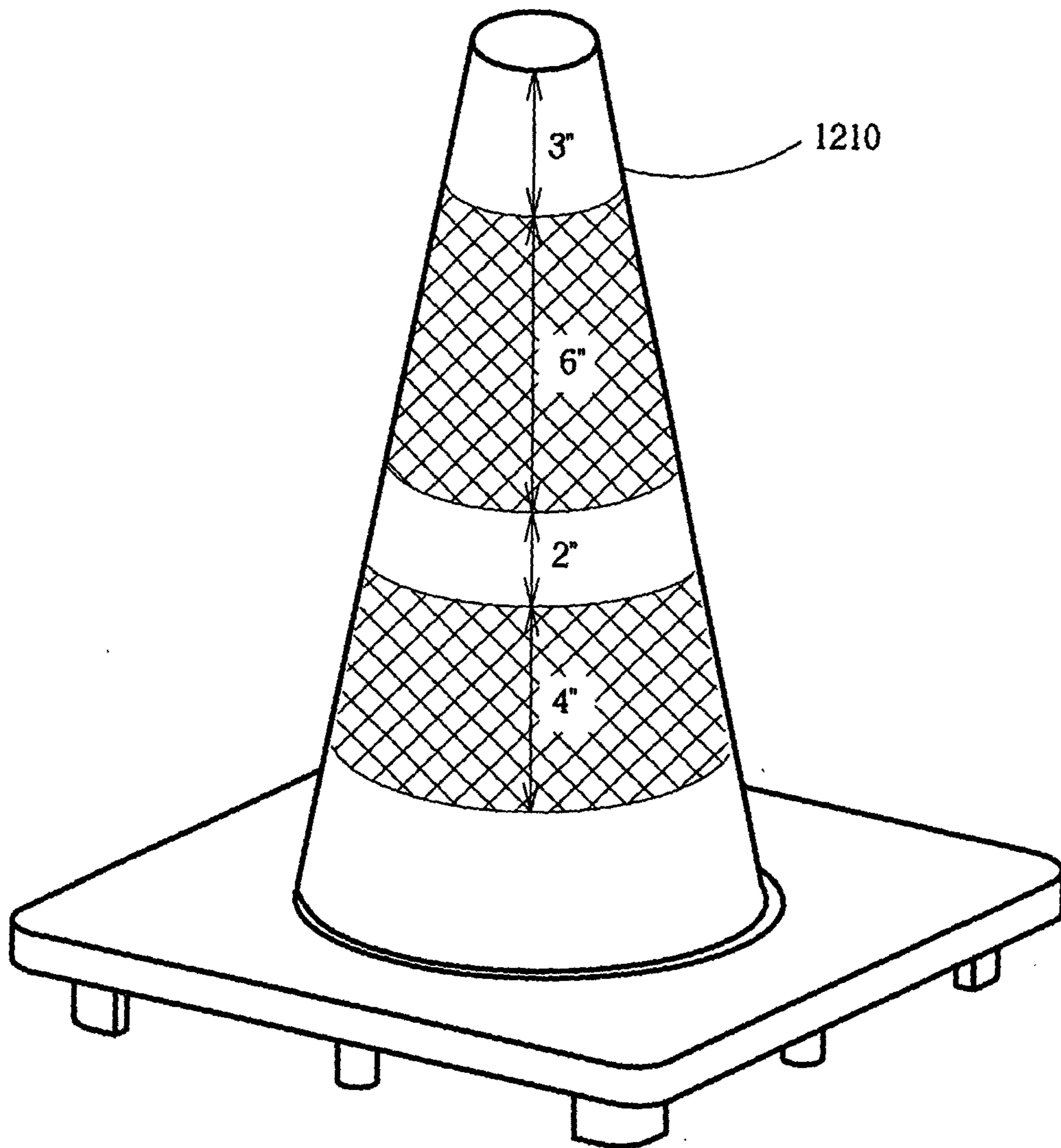

1200 →

Fig. 12

11/13

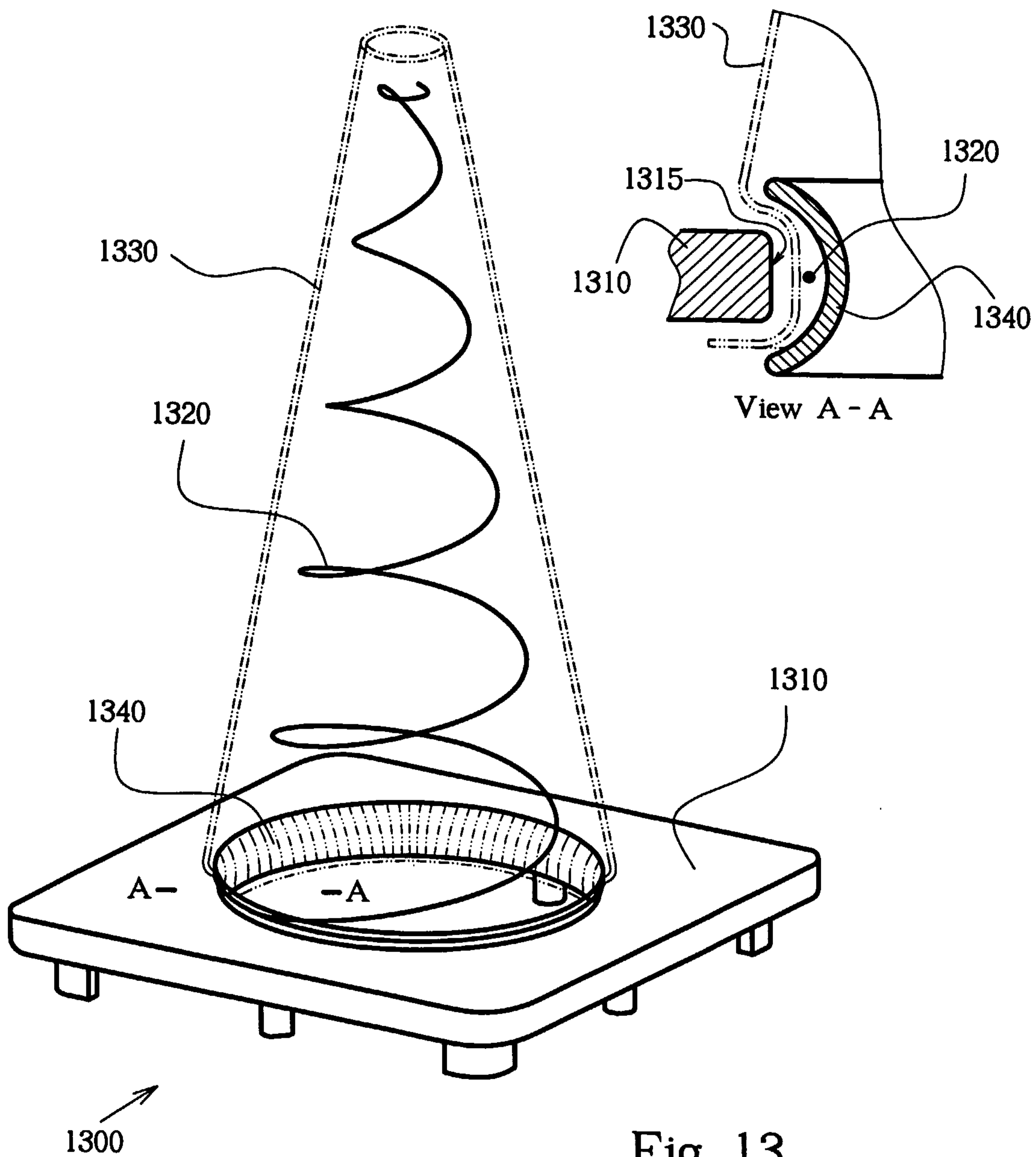

Fig. 13

12/13

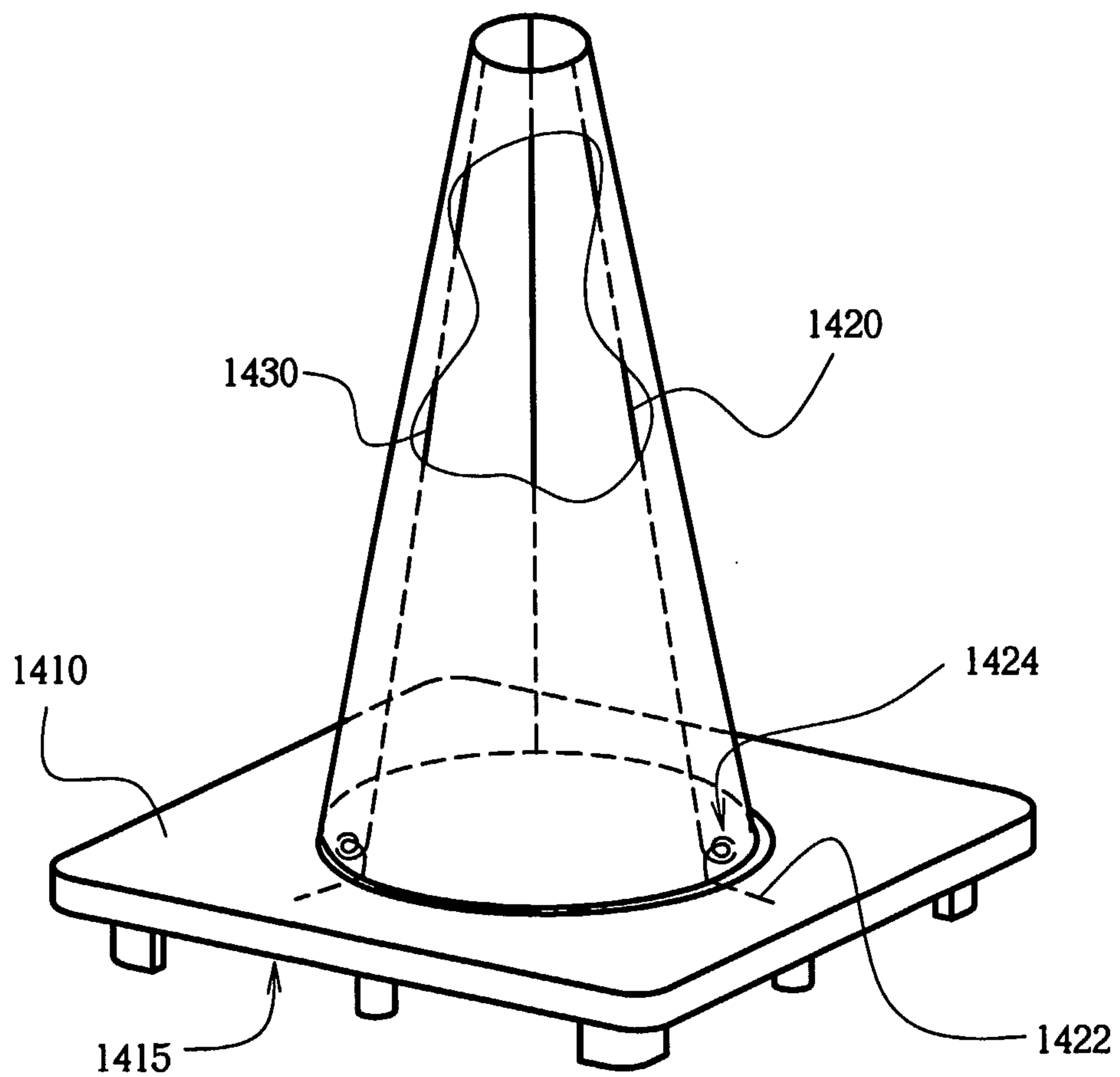

Fig. 14

13/13

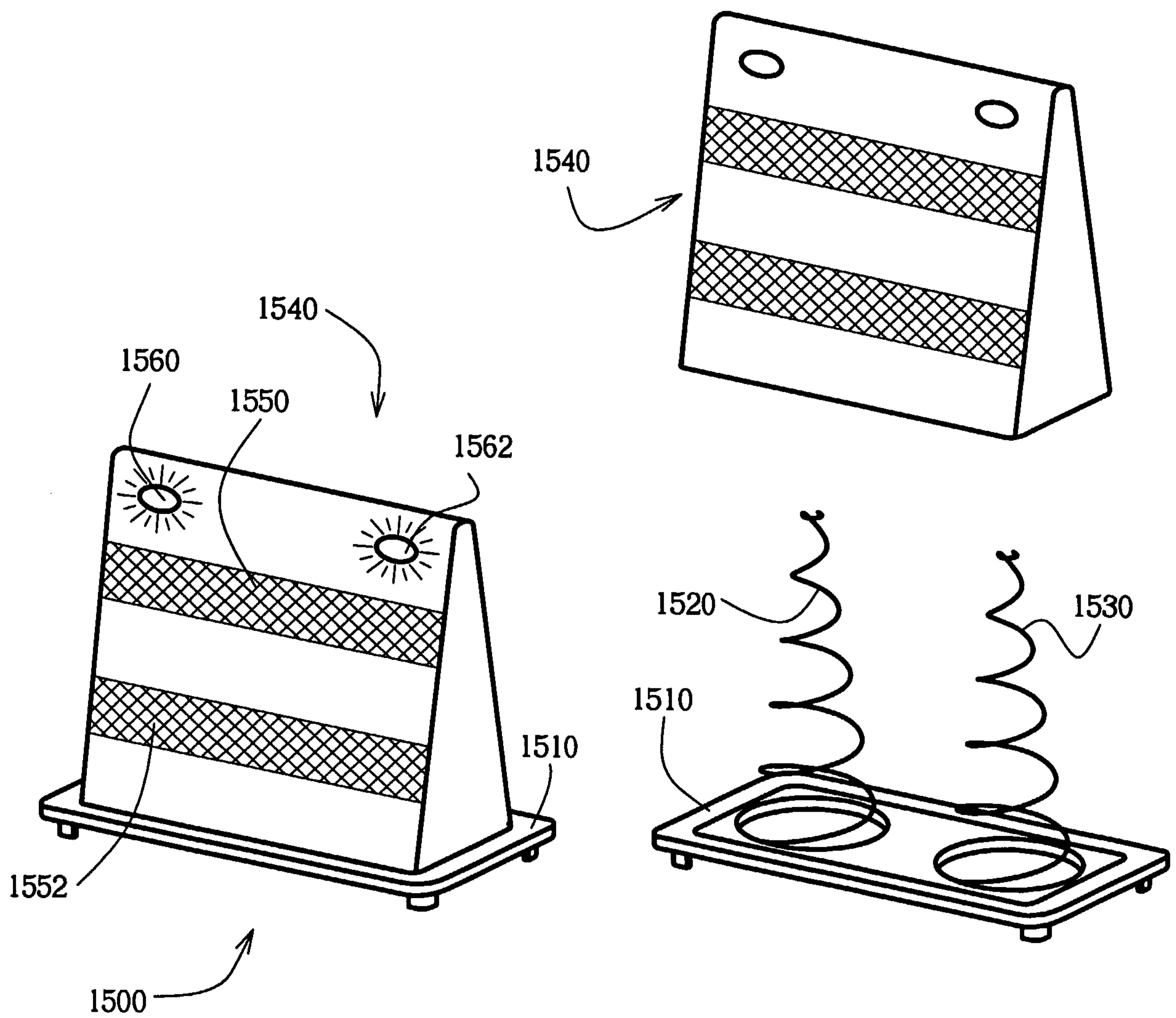

Fig. 15

