



US 20100107531A1

(19) **United States**  
(12) **Patent Application Publication**  
**Hunsaker**

(10) **Pub. No.: US 2010/0107531 A1**  
(43) **Pub. Date: May 6, 2010**

(54) **THIN BRICK MATRIX PANEL AND RELATED METHODS AND SYSTEMS**

**Publication Classification**

(76) Inventor: **Garrick Hunsaker**, Herriman, UT (US)

(51) **Int. Cl.**  
**E04C 1/00** (2006.01)  
(52) **U.S. Cl.** ..... **52/314; 52/434; 52/747.1; 52/745.19**

Correspondence Address:  
**STOEL RIVES LLP - SLC**  
**201 SOUTH MAIN STREET, SUITE 1100, ONE**  
**UTAH CENTER**  
**SALT LAKE CITY, UT 84111 (US)**

(57) **ABSTRACT**

A thin brick system and method for forming a thin brick wall includes a matrix in which channels are formed for receiving a plurality of thin brick units. The thin brick units are bonded to the matrix using mortar and the same mortar can be used to fill spaces between adjacent bricks. The matrix may be attached to a substrate using fasteners. The channels can be formed in the matrix on-site.

(21) Appl. No.: **12/266,416**

(22) Filed: **Nov. 6, 2008**

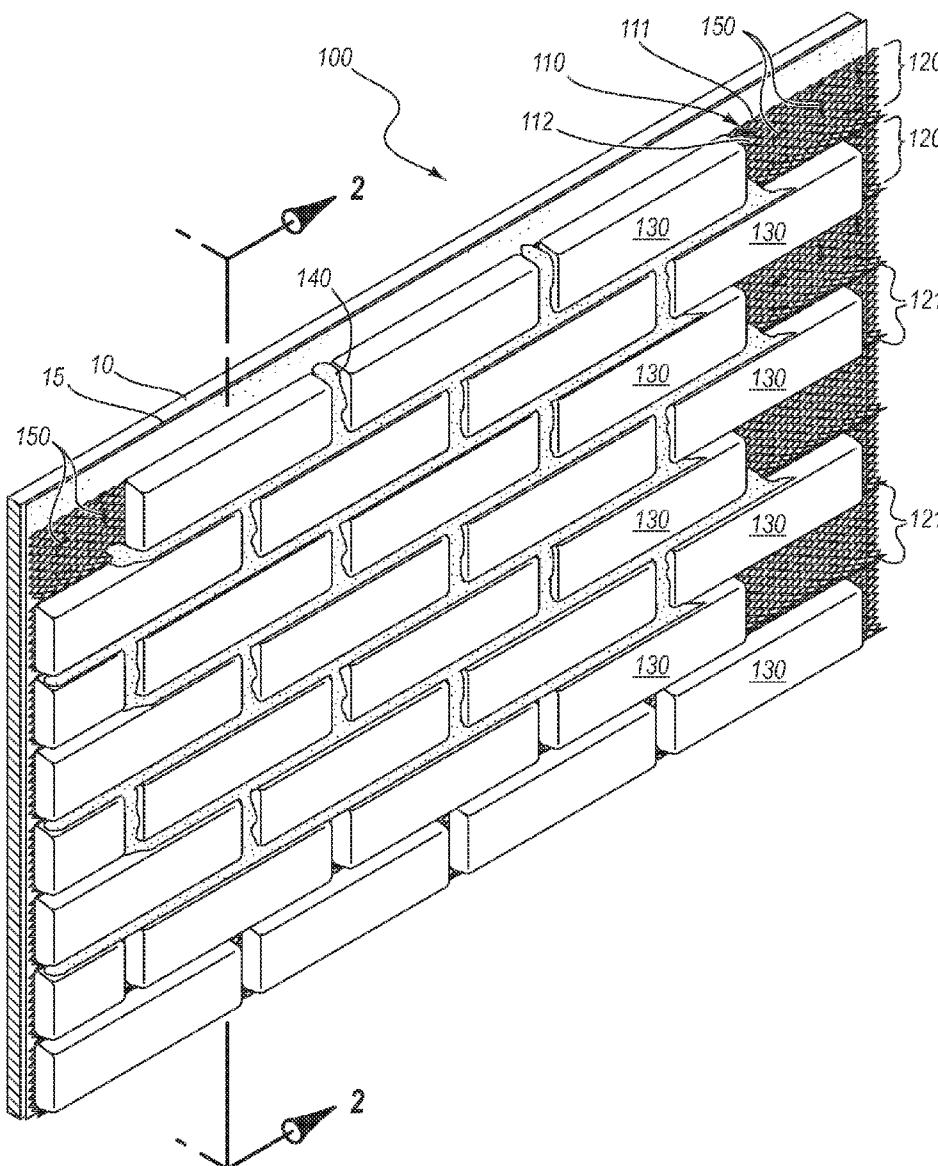

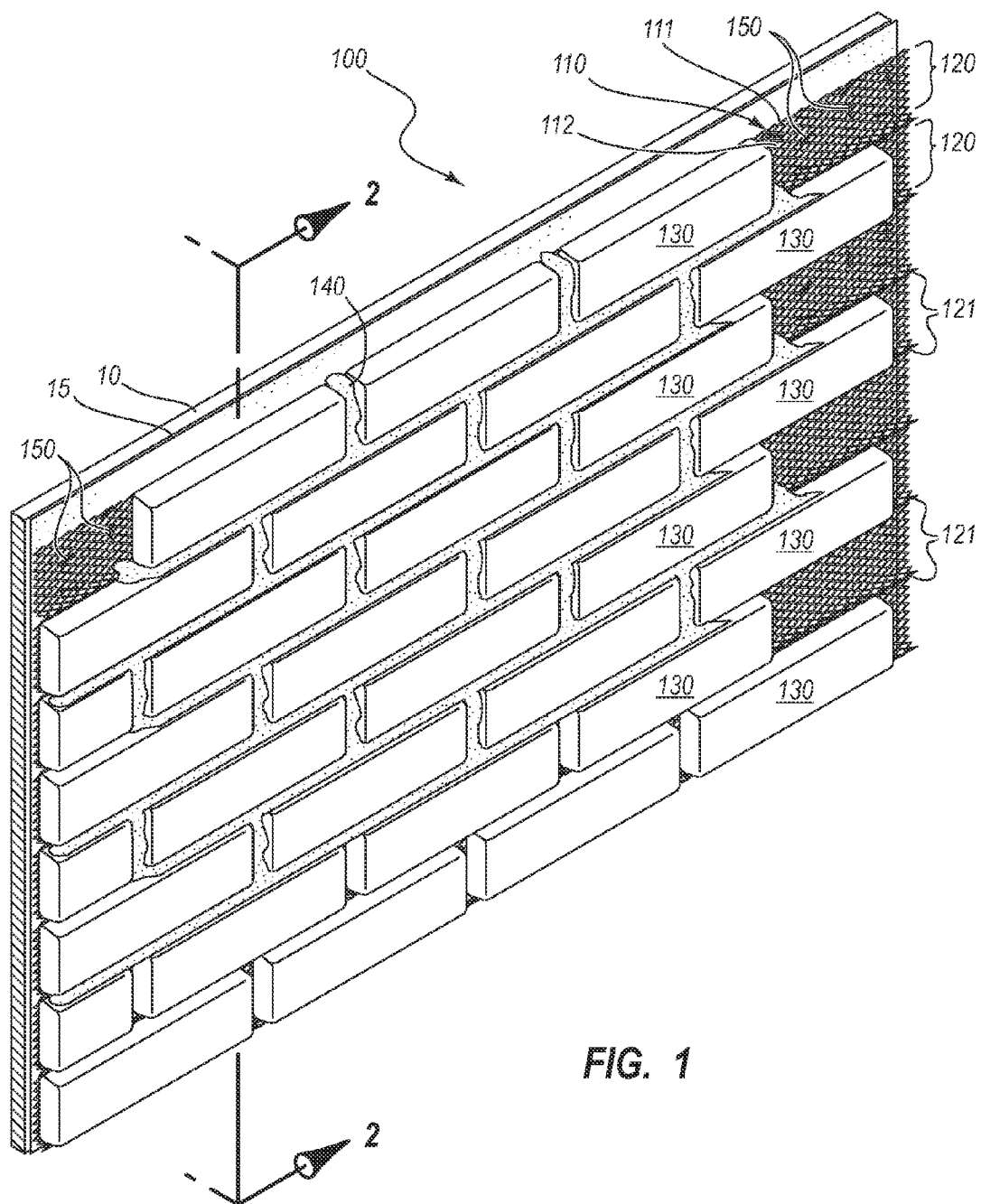

FIG. 1

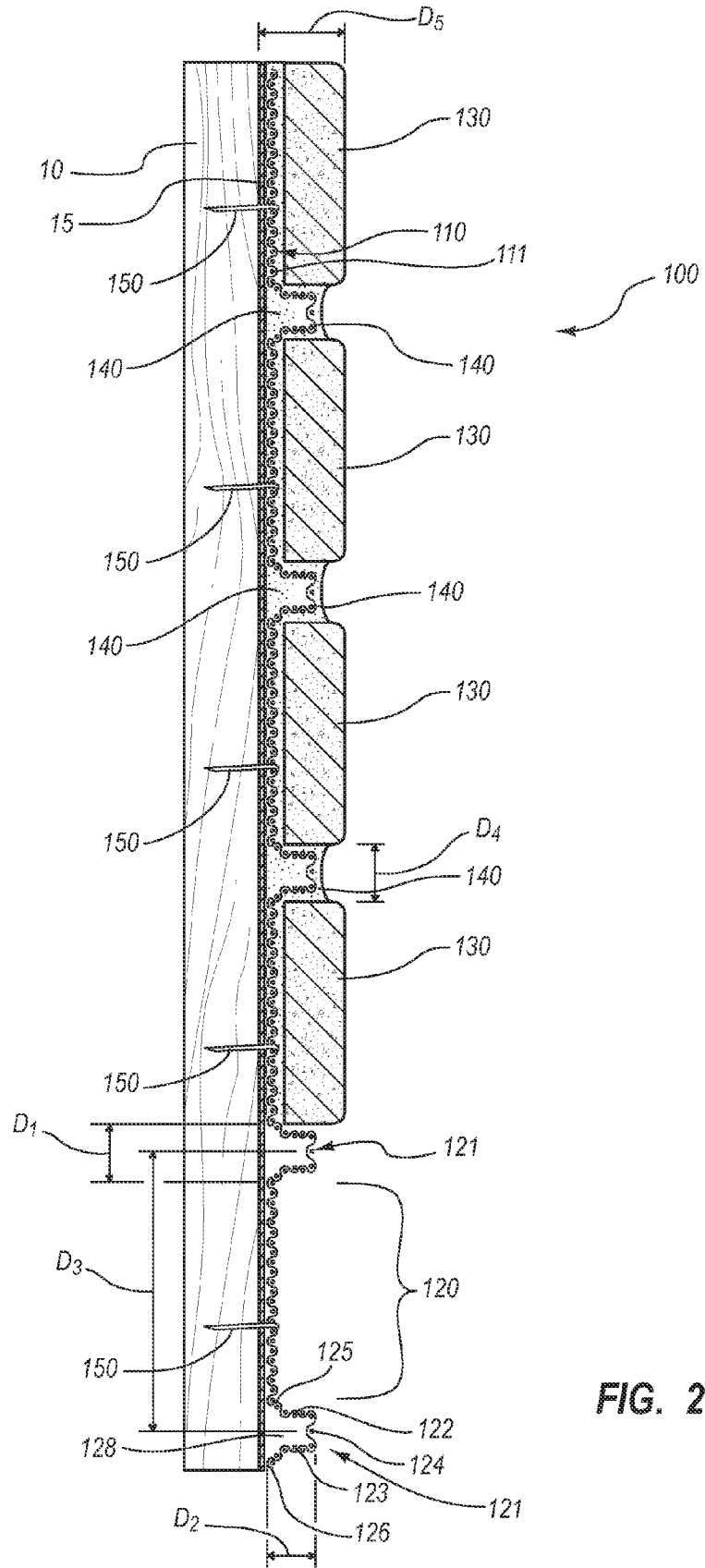

FIG. 2

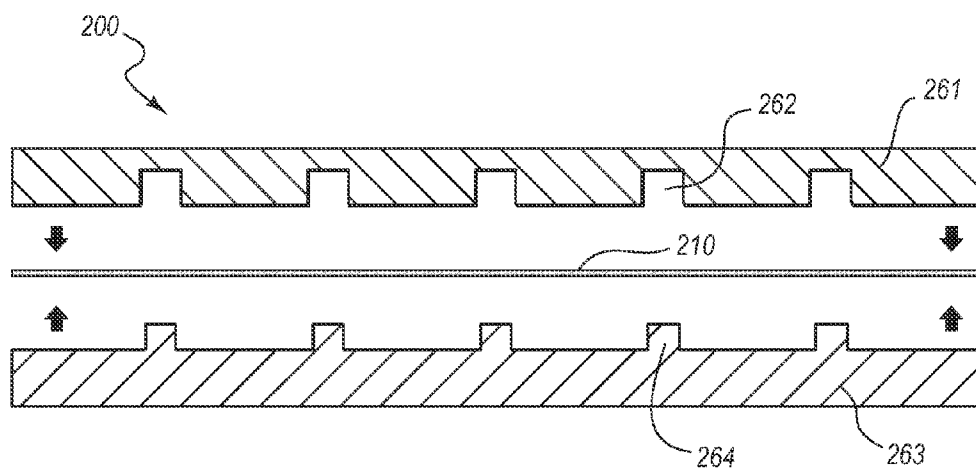

FIG. 3

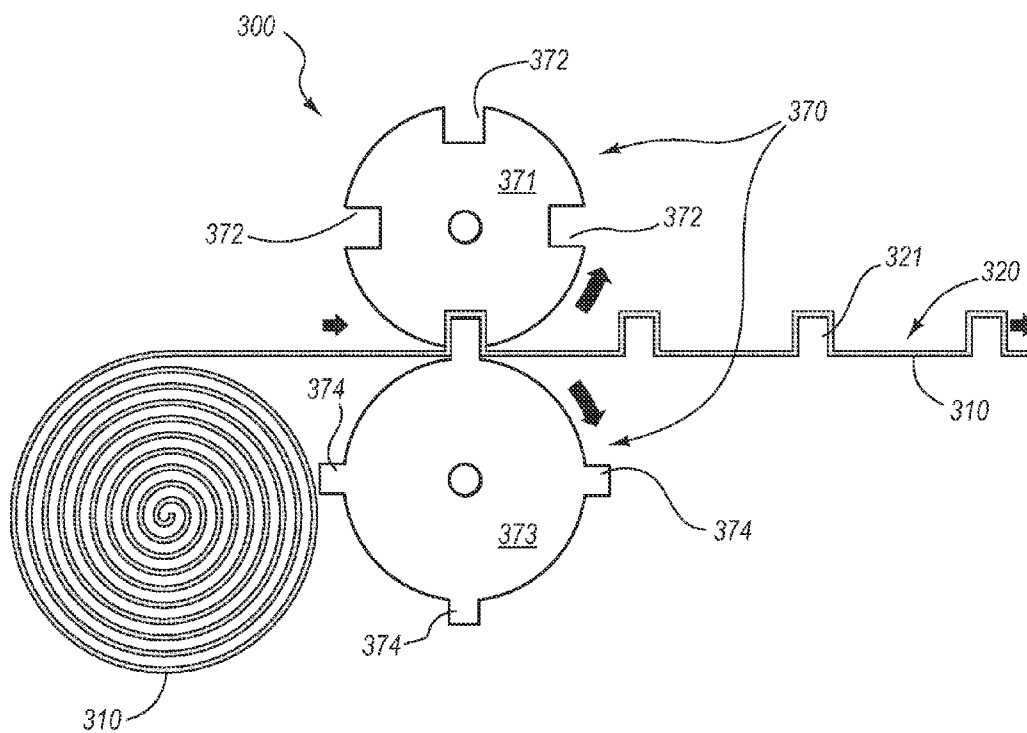

FIG. 4

**THIN BRICK MATRIX PANEL AND RELATED METHODS AND SYSTEMS**

TECHNICAL FIELD

[0001] The present disclosure relates generally to an apparatus and method for forming a brick wall. More specifically, the present disclosure relates to a “thin brick” system and methods which utilize a matrix and mortar to form at least a portion of a wall.

BRIEF DESCRIPTION OF THE DRAWINGS

[0002] The present embodiments will become more fully apparent from the following description and appended claims, taken in conjunction with the accompanying drawings. Understanding that the accompanying drawings depict only typical embodiments, and are, therefore, not to be considered to be limiting of the invention’s scope, the embodiments will be described and explained with specificity and detail in reference to the accompanying drawings as listed below.

[0003] FIG. 1 is a perspective view of a portion of a wall formed by using a system for forming a thin brick wall.

[0004] FIG. 2 is a cross section view of a portion of the wall formed by using the system of FIG. 1.

[0005] FIG. 3 is a cross section view of an apparatus for forming channels in a deformable matrix.

[0006] FIG. 4 is a cross section view of another apparatus for forming channels in a deformable matrix.

INDEX OF ELEMENTS IDENTIFIED IN THE DRAWINGS

- [0007] 10 substrate
- [0008] 15 moisture barrier
- [0009] 100 thin brick system
- [0010] 110 matrix-type receiving panel
- [0011] 111 cross member of matrix
- [0012] 112 aperture of matrix
- [0013] 120 channel
- [0014] 121 protrusion
- [0015] 122 first side of protrusion
- [0016] 123 second side of protrusion
- [0017] 124 apex of protrusion
- [0018] 125 first bend
- [0019] 126 second bend
- [0020] 128 void of channel
- [0021] 130 thin brick units
- [0022] 140 mortar
- [0023] 150 fastener
- [0024] 200 press apparatus
- [0025] 210 matrix panel
- [0026] 261 first portion of press
- [0027] 262 recesses
- [0028] 263 second portion of press
- [0029] 264 protrusions
- [0030] 300 roller apparatus
- [0031] 310 matrix panel
- [0032] 320 channel
- [0033] 321 protrusion
- [0034] 370 rollers
- [0035] 371 first roller
- [0036] 372 recesses

- [0037] 373 second roller
- [0038] 374 protrusions

DETAILED DESCRIPTION OF PREFERRED EMBODIMENTS

[0039] It will be readily understood that the components of the embodiments as generally described and illustrated in the figures herein could be arranged and designed in a wide variety of different configurations. Thus, the following more detailed description of various embodiments, as represented in the figures, is not intended to limit the scope of the invention, as claimed, but is merely representative of various embodiments. While the various aspects of the embodiments are presented in drawings, the drawings are not necessarily drawn to scale unless specifically indicated.

[0040] The phrases “connected to,” “coupled to” and “in communication with” refer to any form of interaction between two or more entities, including mechanical, electrical, magnetic, electromagnetic, fluid, and thermal interaction. Two components may be coupled to each other even though they are not in direct contact with each other. The term “abutting” refers to items that are in direct physical contact with each other, although the items may not necessarily be attached together.

[0041] Architectural thin face brick, commonly referred to as “thin brick”, is typically kiln dried brick units that have height and width dimension similar to those dimensions of conventional brick, but have a relatively small thickness. Some other thin brick units are formed from concrete. Such thin brick is typically used as a decorative element to an existing architectural structure. A thin brick receiving panel, such as a panel of foam or metal is typically adhered to a structure with an adhesive. The adhesive holding the panel to the structure is usually allowed to dry over night, and then the thin brick units are coupled to the panel also using an adhesive, which typically requires over night curing. Finally, the thin brick are typically grouted with mortar to give the resulting panel the appearance of a panel formed from full-sized brick units.

[0042] FIG. 1 depicts a thin brick system 100 from a perspective view. Thin brick system 100 may comprise a matrix-type brick receiving panel 110, a plurality of thin brick units 130, mortar 140, and a plurality of fasteners 150. Thin brick system 100 is configured to allow mortar 140 to be used to adhere bricks 130 to matrix-type brick receiving panel 110, wherein the mortar becomes enmeshed in the matrix of the panel. Mortar 140 also binds bricks 130 to each other and is grouted into spaces between adjacent thin brick units to form mortar joints. Thin brick system 100 as described herein may be employed to form a wall or decorative element on an exterior or interior portion of a structure. Additionally, the thin brick stem described herein may be used in various methods for forming a thin brick wall.

[0043] Matrix-type brick receiving panel 110 may comprise a plurality of cross members 111, which form a plurality of apertures 112 such that the matrix may be called a mesh, web, or lath. Matrix 110 also comprises channels 120 that are defined by laterally extending protrusions 121, wherein the protrusions are configured such that when the matrix is coupled to a substrate, the protrusions form a substantially horizontal channel.

[0044] Channels 120 may extend across the width of matrix panel 110 and are configured to provide proper spacing between adjacent rows of brick such that spaces can be

formed between rows and/or columns of brick. As such, protrusions **121** may be called spacing members. Channels **120** are configured to receive and provide support for mortar **140** and bricks **130**. In the depicted embodiment, the height of channel **120** is greater than the height of a brick such that mortar **140** can be located between a brick and a protrusion **121**. Matrix **110** is configured such that mortar **140** becomes enmeshed with the cross members and apertures **111** and **112** of the matrix. The matrix may be coupled to a structure substrate **10** using a plurality of fasteners **150**.

**[0045]** In the depicted embodiment, matrix **110** comprises a piece of galvanized steel diamond lath of the type well known in construction. In one embodiment, the diamond lath comprises a panel of diamond lath matrix that is about 2 feet high and has a width (lateral length) of about 8 feet. Multiple panels of matrix **110** can be employed to build a thin brick wall or element of any size. A contiguous wall of thin bricks can be constructed from the system disclosed herein using multiple panels of matrix **110** by overlapping the edges of adjacent matrix panels. When panels of matrix **110** are overlapped vertically, the tops and/or bottoms of the panels may be spaced such that channels **120** of the two adjacent panels of matrix are evenly spaced vertically. When multiple panels of matrix **110** are overlapped horizontally, the adjacent sides of the panel may be positioned such that a horizontal continuity of channel **120** is maintained and such that a course of brick built on the channel maintains a level or other predetermined orientation.

**[0046]** Another feature of the thin brick system disclosed herein is that the system allows for rapid and simple construction of corners. One or more cross members **111** that are located at protrusions **121** of a matrix panel **110** can be cut, which allows the panel to be bent around a corner. The bent matrix panel **110** can be attached to the substrate on each side of the corner by mechanical fasteners **150**.

**[0047]** As will be appreciated by those skilled in the art, a variety of types and configurations of matrix-type thin brick receiving panels can be utilized without departing from the scope and spirit of the present invention. For example, in one embodiment matrix **110** comprises 2.5 gage galvanized steel diamond lath while in another it may be 3.5 gage. Matrix **110** may comprise any suitable deformable material, such as a deformable metal matrix. Matrix **110** may comprise any suitable dimension or shape; for example round. Further, matrix **110** can be configured such that a user cut the matrix to a custom shape.

**[0048]** Thin bricks **130** may comprise any type known in the art, and may be coupled to matrix **110** such that their long axes are horizontally oriented, or alternatively, the bricks may be placed such that they are vertically oriented. In the depicted embodiment, bricks **130** comprise rectangular shapes, however, in alternative embodiments, the bricks may comprise other shapes such as square, round, or rock-like elements. Further, bricks **130** may be arranged to form decorative elements such as circles or geometric patterns, wherein different colors or shapes of bricks may be employed.

**[0049]** Mortar **140** may be of any type known in the art and is configured to couple bricks **130** to matrix **110** as well as couple the bricks to each other. In the depicted embodiment, mortar **140** is grouted into spaces between adjacent bricks **130** such that the mortar forms horizontally and vertically oriented portions. Mortar **140** can be finished in a variety of manners that are known in the art. Mortar **140** may be initially placed on a back, top, left, and/or right side of brick **130**, and

then the brick is pressed onto matrix **140**, the mortar may be initially placed on the matrix, and then a brick is pressed into the mortar, or a combination of placing mortar on the matrix and the brick may be used.

**[0050]** A plurality of fasteners **150** may be employed to anchor matrix **110** to a substrate **10**, such as a skin of plywood, metal or wooden studs, or some other suitable element of the structure. In the depicted embodiment of FIG. 1 and FIG. 2, fasteners **150** are configured to project through an aperture **112** of matrix **110** such that a body portion of the fastener projects into a substrate **10**. A head portion of the fastener is configured to abut at least a portion of a cross member **111** of the matrix on a substrate-distal side of the matrix. In this way, the matrix can be anchored to the substrate. In the depicted embodiment, fasteners **150** comprise staples, however in alternative embodiments, the mounting hardware may comprise nails or screws, and may further comprise washer members. A moisture barrier **15**, which comprises a water repellant material such as tar paper may be located between substrate **10** and matrix **110**. The tar paper may be overlapped to prevent water from seeping between adjacent sections of the tar paper. Moisture barrier **15** is an optional component, and some embodiments of system **100** may not include a moisture barrier. Since matrix **110** and the resulting thin brick wall are attached to substrate **10** with fasteners rather than a layer of adhesive, a liquid that finds its way behind the thin brick wall can flow between the back side of the wall and the tar paper without becoming trapped therein and resulting in water damage to the substrate, such as mildew, or rot.

**[0051]** FIG. 2 is a cross section view of a portion of a wall formed according to thin brick system **100**. As described above, system **100** comprises a matrix panel **110** for receiving thin brick units **130**. Bricks **130** are attached to matrix panel **110** and to each other by mortar **140**, which becomes enmeshed in the matrix panel. Matrix panel **110** is anchored to substrate **10** by a plurality of mechanical fasteners **150**.

**[0052]** A plurality of horizontally oriented laterally oriented channels **120** define a front face of matrix panel **110** and are formed by laterally extending protrusions **121**, which in the depicted embodiment comprise a substantially square transverse cross section. In other embodiments, protrusions **121** may comprise substantially triangular or rectangular cross sections.

**[0053]** Protrusions **121** may be formed in matrix panel **110** after the matrix panel has been manufactured, and as such, the protrusions are integral to the matrix panel. In one embodiment, protrusions **121** are formed on-site by a user, and in another embodiment, the protrusions are formed off-site. Protrusions **121** may be formed by pressing or rolling matrix panel **110**. Protrusions **121** may comprise a first side **122**, a second side **123**, and an apex **124**, wherein the first side is located between a first bend **125** and apex **124**, and the second side is located between a third bend **126** and apex. Apex **124** itself may define a second bend. A void **128** may be formed by the bending of panel **110** to create protrusions **121**.

**[0054]** In the depicted embodiment, a transverse cross section of protrusion **121** is substantially square, but may also be described as being rectangular and may be somewhat ovalized at apex **124**. The transverse cross sectional shape of protrusion **121** may vary from the depicted embodiment, and may comprise a triangular, rectangular, or oval shape. The distance to which a protrusion **121** protrudes from matrix panel **110** may be varied according to different applications,

and in the depicted embodiment, that distance is less than the width of a thin brick unit **130**. Thus, it can be said that protrusions **121** have a height that is less than that of a thin brick unit **130**. In an alternative embodiment, when the thin brick wall formed by system **100** is finished, the distance  $D_2$  to which a protrusion **121** protrudes is less than about  $\frac{1}{2}$  of the width of a thin brick unit **130**, when the brick unit is coupled to matrix **10**, as depicted in FIG. 2.

[0055] In one embodiment, the height of a protrusion FIG. 2,  $D_1$ , is within a range of about 0.25 inches and 1.5 inches. The depth  $D_2$  that a laterally extending protrusion might protrude from the front side of the matrix as depicted in FIG. 2 may comprise a range of about 0.2 inches to about 1.0 inches. In another embodiment,  $D_1$  is about 0.75 inches. In another embodiment,  $D_2$  is about 0.5 inches.

[0056] In one embodiment, the height  $D_3$  of a laterally oriented channel is about 2.5 inches to about 3.0 inches high as measured between the apexes of adjacent protrusions, and the channel is configured to receive thin brick units that are about 2.25 inches high. In the above embodiment if rectangular shaped thin brick units are adhered within the channel, the thin brick units are oriented such that their long axes are horizontally oriented. In one embodiment,  $D_3$  is about 2.75 inches. In another embodiment, the height of the channel  $D_3$  is between about 8.0 inches and 8.5 inches high as measured between protrusion apexes and the channel is configured to receive thin brick units that are about 7.625 inches high. If rectangular thin brick units are used in this embodiment, the thin brick units are oriented with their long axes vertically oriented. In another embodiment,  $D_3$  is about 8.125 inches.

[0057] Mortar can initially be applied to matrix panel **110**, a thin brick unit **130**, or both the matrix panel and a thin brick unit. A thin brick unit **130** can then be pressed into place, and when a number of bricks have been placed, mortar can be grouted into spaces in between adjacent brick units to form mortar joints. Applying mortar to matrix panel **110**, pressing a thin brick unit **130** into place, and forming mortar joints causes mortar **140** to be pressed into and enmeshed with matrix panel **110**. Thus cross members of matrix panel **110** may become embedded within mortar **140**, apertures of the matrix panel may become at least partially filled with the mortar, and void **128** of a protrusion **121** may become at least partially filled with mortar. In one embodiment, mortar joints formed between adjacent thin brick units have a height or width  $D_4$  within a range of about 0.075 inches and 1.0 inches. Whether  $D_4$  represents a height or a width depends on whether the mortar joint is horizontally or vertically oriented. In another embodiment,  $D_4$  is about 0.31 inches for a mortar joint between bricks in a row and 0.38 inches for a mortar joint between vertically adjacent bricks.

[0058] A distance  $D_5$  from a matrix proximal side of substrate **10** to a substrate distal surface of brick may be smaller than if a foam based system were used. In one embodiment,  $D_5$  comprises a range from about 0.60 inches to about 2.0 inches, wherein the thin brick units have a depth of about 0.5 inches. In other embodiments,  $D_5$  may be greater than 2.0 inches. In one embodiment,  $D_5$  is about 0.75 inches. Also, the distance to which bricks **130** protrude away from substrate **10** may be increased or decreased compared to that illustrated in FIG. 2. Further, the relative distance that some bricks **130** protrude can be varied such that topological differences in substrate **10** can be accommodated and smoothed out. If topological differences in substrate **10** are greater than can be corrected by varying the height of bricks **130**, furring strips or

spacers can be under matrix panel **110**. Finally, varying the distance to which bricks **130** protrude can be used to form designs or decorative elements in a thin brick wall formed by employing system **100**.

[0059] FIG. 3 depicts a press apparatus **200** that can be used to form protrusions in a matrix panel **210**. Apparatus **200** may be considered part of system **100**, and may be employed to form protrusions at a site near which a thin brick wall is to be formed using system **100**.

[0060] Apparatus **200** may comprise a first portion **261** and a second portion **263**. First portion **261** may comprise a plurality of recesses **262** which are configured with a predetermined depth and transverse cross section. Second portion **263** may comprise a plurality of protrusions **264** which are configured with a predetermined height and transverse cross section, wherein the height and cross section are substantially similar to recesses **262**. The transverse cross section of recesses **262** and protrusions **264** may vary from the depicted embodiment and may comprise a substantially rounded, ovalized, square, or rectangular shape. The length and width of first and second portions **261** and **263** may be approximately equal to the length and width of a matrix panel **210**, or may comprise a multiple or a fraction of the length and width of the matrix panel.

[0061] Recesses **262** and protrusions **264** are spaced such that when first and second portions **261** and **263** are pressed together, the protrusions may enter the recesses. When a matrix panel **210** is placed between first and second portions **262** and **264** and the portions are pressed together, the matrix panel may become deformed similarly to the shapes of protrusions and recesses **262** and **264**, resulting in a matrix panel similar to panel **110** described herein. The spacing of recesses and protrusions **262** and **264** are of a predetermined distance such that the resulting channels defined by protrusions formed by press apparatus **200** in matrix panel **210** may be used to receive thin brick units as described herein.

[0062] The components and features of apparatus **200** may be varied to produce matrix panels of different types, than described herein. For example, the depth and height of recess and protrusions **262** and **264** may be greater or lesser than depicted such that the depths of channels formed in panel **210** are altered. Apparatus **200** may be used in one or more methods for forming a thin brick wall. Apparatus **200** may be mobile, wherein it is easily packed and shipped between locations such that a distributor of thin brick systems as described herein, can ship apparatus **200** with components of the thin brick system to a user. Alternatively, apparatus **200** may be mounted on a vehicle, or may be delivered from site to site via a vehicle.

[0063] FIG. 4 depicts a roller apparatus **300** that can be used to form protrusions in a deformable matrix **310**. Apparatus **300** may be considered part of system **100**, and may be employed to form protrusions at a site near which a thin brick wall is to be formed using system **100**. In the depicted embodiment, matrix **310** is in a rolled configuration; however, the matrix may comprise panels or sheets.

[0064] Apparatus **300** may comprise a first roller **371** and a second roller **373**. First portion **371** may comprise a plurality of recesses **372** which are configured with a predetermined depth and transverse cross section. Second roller **373** may comprise a plurality of protrusions **374** which are configured with a predetermined height and transverse cross section, wherein the height and cross section are substantially similar to recesses **372**. The transverse cross section of recesses **372**

and protrusions 374 may vary from the depicted embodiment and may comprise a substantially rounded, ovalized, square, or rectangular shape. The width of recesses and protrusions 372 and 374 that are located on first and second rollers 371 and 373 may be approximately equal to the width of a matrix 310, or may comprise a multiple or a fraction of the length and width of the matrix.

[0065] Recesses 372 and protrusions 374 are spaced such that when first and second rollers 371 and 373 are rolled in a synchronous manner, the protrusions may enter the recesses. When a matrix 310 is placed between first and second rollers 372 and 374 and the rollers are rolled synchronously, a portion of matrix 310 may be forced into recess 721 by protrusion 374 thereby deforming the matrix similarly to the shapes of protrusions and recesses 372 and 374. The result may be a matrix similar to panel 110 described herein. The spacing of recesses and protrusions 372 and 374 are of a predetermined distance such that the resulting channels 320 defined by protrusions 321 formed by roller apparatus 300 in matrix 310 may be used to receive thin brick units as described herein.

[0066] The components and features of apparatus 300 may be varied to produce matrix-type thin brick receiving members of different types compared to those described herein. For example, the depth and height of recess and protrusions 372 and 374 may be greater or lesser than depicted such that the depths of channels formed in panel 310 are altered. Apparatus 300 may be used in one or more methods for forming a thin brick wall. Apparatus 300 may be mobile, wherein it is easily packed and shipped between locations such that a distributor of thin brick systems as described herein, can ship apparatus 300 with components of the thin brick system to a user. Alternatively, apparatus 300 may be mounted on a vehicle, or may be delivered from site to site via a vehicle.

[0067] The matrix-type thin brick receiving panels 110, 210, 310, disclosed herein are examples of means for coupling thin brick units to a substrate. The channels 120, disclosed herein are examples of means for receiving and spacing thin brick units. The protrusions 121, 321 disclosed herein are examples of means for spacing thin brick units. Mortar 140 disclosed herein is an example of means for adhering thin brick units to a thin brick receiving panel; means for adhering thin brick units to each other; and, means for forming mortar joints between adjacent bricks. The mechanical fasteners 150 disclosed herein are examples of means for attaching a matrix-type thin brick receiving member to a substrate. Press apparatus 200 and roller apparatus 300 are examples of means for forming protrusions in a matrix-type thin brick receiving member.

[0068] Furthermore, any methods disclosed herein comprise one or more steps or actions for performing the described method. The method steps and/or actions may be interchanged with one another. In other words, unless a specific order of steps or actions is required for proper operation of the embodiment, the order and/or use of specific steps and/or actions may be modified.

[0069] Without further elaboration, it is believed that one skilled in the art can use the preceding description to utilize the present disclosure to its fullest extent. The examples and embodiments disclosed herein are to be construed as merely illustrative and not a limitation to the scope of the present disclosure in any way. It will be apparent to those having skill in the art that changes may be made to the details of the above-described embodiments without departing from the underlying principles of the disclosure described herein. In

other words, various modifications and improvements of the embodiments specifically disclosed in the description above are within the scope of the appended claims. Note that elements recited in means-plus-function format are intended to be construed in accordance with 35 U.S.C. §112 ¶6. The scope of the invention is therefore defined by the following claims.

1. A matrix panel for use in a thin brick panel system with thin bricks,
  - wherein the matrix panel comprises a front side, a back side, a left side, a right side, a top side, and a bottom side, wherein the front side has a plurality of laterally oriented channels that each are sized and configured to receive a plurality of thin brick units that are adhered to the channel by mortar,
  - wherein the channels are each defined by a pair of laterally extending protrusions that are integrally formed with the matrix panel,
  - wherein the plurality of laterally extending protrusions are positioned to provide proper spacing between the thin brick units to enable the thin brick units to form rows, and
  - wherein each laterally extending protrusion has a height that is less than the thickness of the thin brick units and each laterally extending protrusion has a width that is sufficient to enable a mortar joint to be formed on each laterally extending protrusions between rows of thin brick units and between horizontally adjacent thin brick units.
2. The matrix panel of claim 1, wherein each laterally extending protrusion has a substantially square transverse cross section.
3. The matrix panel of claim 1, wherein the matrix panel comprises a steel diamond lath.
4. The matrix panel of claim 3, wherein the matrix panel comprises 2.5 gage steel diamond lath.
5. The matrix panel of claim 3, wherein the matrix panel comprises 3.5 gage steel diamond lath.
6. The matrix panel of claim 3, wherein the panel has a height of about 2 feet and a width of about 8 feet.
7. The matrix panel of claim 3, wherein the plurality of laterally extending protrusions each have a height of about 0.25 inches to about 1.5 inches.
8. The matrix panel of claim 3, wherein the plurality of laterally extending protrusions each have a depth of about 0.2 inches to about 2.0 inches.
9. The matrix panel of claim 3, wherein the plurality of laterally oriented channels each have a height of about 2.5 inches to about 3.5 inches.
10. A thin brick panel system, comprising:
  - a matrix panel for use with thin bricks;
    - wherein the matrix panel comprises a front side, a back side, a left side, a right side, a top side, and a bottom side;
  - a plurality of mechanical fasteners for securing the panel to a substrate; and,
  - a plurality of thin brick units,
    - wherein the front side of the matrix panel has a plurality of laterally oriented channels that each are sized and configured to receive some of the plurality of thin brick units, wherein the thin brick units are adhered to the channels by mortar,

wherein the channels are each defined by a pair of laterally extending protrusions that are integrally formed with the matrix panel,

wherein the plurality of laterally extending protrusions are positioned to provide proper spacing between the thin brick units to enable the thin brick units to form rows, and

wherein each laterally extending protrusions has a height that is less than the thickness of the thin brick units and each laterally extending protrusion has a width that is sufficient to enable a mortar joint to be formed on each laterally extending protrusions between rows of thin brick units and between horizontally adjacent thin brick units.

11. The system of claim 6, wherein each laterally extending protrusion has a substantially square transverse cross section.

12. The system of claim 7, wherein the matrix panel comprises 2.5 gage steel diamond lath.

13. The system of claim 7, wherein the matrix panel comprises 3.5 gage steel diamond lath.

14. A method for forming a section of thin bricks, comprising:

providing a matrix panel having a front side and a back side, the front side defining a plurality of laterally oriented channels,

the channels each defined by a pair of laterally extending protrusions that are integrally formed with the matrix panel;

wherein the laterally extending protrusions are positioned to provide proper spacing between the thin brick units to enable the thin brick units to form rows, and

fastening the matrix panel to a substrate via one or more mechanical fasteners;

applying mortar to the panel within the plurality of channels; and,

pressing a plurality of thin brick units into the mortar;

wherein each laterally extending protrusion has a height that is less than the thickness of the thin brick units and each laterally extending protrusion has a width that is sufficient to enable a mortar joint to be formed on each laterally extending protrusion between rows of thin brick units.

15. The method of claim 10, wherein the method further comprises applying mortar within the mortar joint.

16. The method of claim 10, wherein the method further comprises mechanically fastening the matrix panel to a substrate.

17. A thin brick wall comprising:

a plurality of thin brick units adhered to a matrix panel and each other by mortar,

wherein the mortar is enmeshed with cross members and apertures in the matrix panel and the mortar forms mortar joints between rows and horizontally adjacent thin brick units,

wherein the matrix panel comprises a plurality of laterally oriented channels that are defined by a pair of

laterally extending protrusions and the matrix panel is anchored to a substrate via a plurality of mechanical fasteners.

18. The thin brick wall of claim 13, wherein the matrix panel comprises diamond steel lath.

19. The thin brick wall of claim 13, wherein each of the laterally extending protrusions comprise a substantially square transverse cross section.

20. The thin brick wall of claim 13, wherein each thin brick unit has a front face, a rear face, a top side, a bottom side,

wherein the wall comprises some thin brick units that have other thin brick units immediately adjacent to them on their top side, bottom side left side and right side such that they can be said to be surrounded by other thin brick units, and

wherein those thin brick units that are surrounded by other thin brick units are each contacted by mortar on their back face, top side, bottom side, left side and right side.

21. A method for forming a section of thin bricks, comprising:

providing a matrix panel having a front side and a back side;

forming a plurality of laterally extending protrusions such that a pair of laterally extending protrusions defines a laterally extending channel;

wherein the laterally extending protrusions are positioned to provide proper spacing between the thin brick units to enable the tin brick units to form rows,

fastening the matrix panel to a substrate via one or more mechanical fasteners;

applying mortar to the panel within the plurality of channels; and, pressing a plurality of thin brick units into the mortar;

wherein each laterally extending protrusion has a height that is less than the thickness of the thin brick units and each laterally extending protrusion has a width that is sufficient to enable a mortar joint to be formed on each laterally extending protrusion between rows of thin brick units.

22. The method of claim 17, wherein the plurality of laterally extending protrusions are formed in the matrix panel by employing a press, the press comprising:

a first portion that has at least one recess, and

a second portion that has at least one protrusion;

wherein the protrusion of the first portion forces a portion of the matrix panel into the recess of the second portion.

23. The method of claim 17, wherein the plurality of laterally extending protrusions are formed in the matrix panel by feeding the matrix panel through a roller apparatus, the roller apparatus comprising:

a first roller that has at least one recess, and

a second roller that has at least one protrusion;

wherein the protrusion of the first roller forces a portion of the matrix panel into the recess of the second roller.

\* \* \* \* \*