



(51) International Patent Classification:
B60R 13/02 (2006.01)

(21) International Application Number:

PCT/US2014/039224

(22) International Filing Date:

22 May 2014 (22.05.2014)

(25) Filing Language:

English

(26) Publication Language:

English

(30) Priority Data:

61/826,173 22 May 2013 (22.05.2013) US

(71) Applicant: **JOHNSON CONTROLS TECHNOLOGY COMPANY** [US/US]; 915 East 32nd Street, Holland, Michigan 49423 (US).

(72) Inventors: **COWELCHUK, Glenn A.**; 317 Winterpine Way, Holland, Michigan 49424 (US). **SPRINGER, Heather Rae**; 9501 Lakeshore Dr., West Olive, Michigan 49460 (US). **FLOWERDAY, Craig David**; 13995 Fox Trail Dr., Holland, Michigan 49424 (US). **RANE, Nikhil Shashikant**; 3183 Country View Lane, Apt. 8, Holland, Michigan 49424 (US). **BALCIKONIS, Justinas**; 2248

Brighton Street, Holland, Michigan 49424 (US). **NEWKIRK, Tyler James**; 536 Paris Ave SE, Grand Rapids, Michigan 49503 (US).

(72) Inventor: **BUTZ, Andrew Robert** (deceased).

(72) Inventor: **HANSEN, Scott Allen**; 447 Pinewood Ct., Holland, Michigan 49424 (US).

(74) Agents: **KANTOR, Andrew L.** et al.; P. O. Box 692289, Houston, Texas 77269 (US).

(81) Designated States (unless otherwise indicated, for every kind of national protection available): AE, AG, AL, AM, AO, AT, AU, AZ, BA, BB, BG, BH, BN, BR, BW, BY, BZ, CA, CH, CL, CN, CO, CR, CU, CZ, DE, DK, DM, DO, DZ, EC, EE, EG, ES, FI, GB, GD, GE, GH, GM, GT, HN, HR, HU, ID, IL, IN, IR, IS, JP, KE, KG, KN, KP, KR, KZ, LA, LC, LK, LR, LS, LT, LU, LY, MA, MD, ME, MG, MK, MN, MW, MX, MY, MZ, NA, NG, NI, NO, NZ, OM, PA, PE, PG, PH, PL, PT, QA, RO, RS, RU, RW, SA, SC, SD, SE, SG, SK, SL, SM, ST, SV, SY, TH, TJ, TM, TN, TR, TT, TZ, UA, UG, US, UZ, VC, VN, ZA, ZM, ZW.

[Continued on next page]

(54) Title: VEHICLE INTERIOR COMPONENT HAVING A MULTI-DIMENSIONAL KNITTED FABRIC PANEL

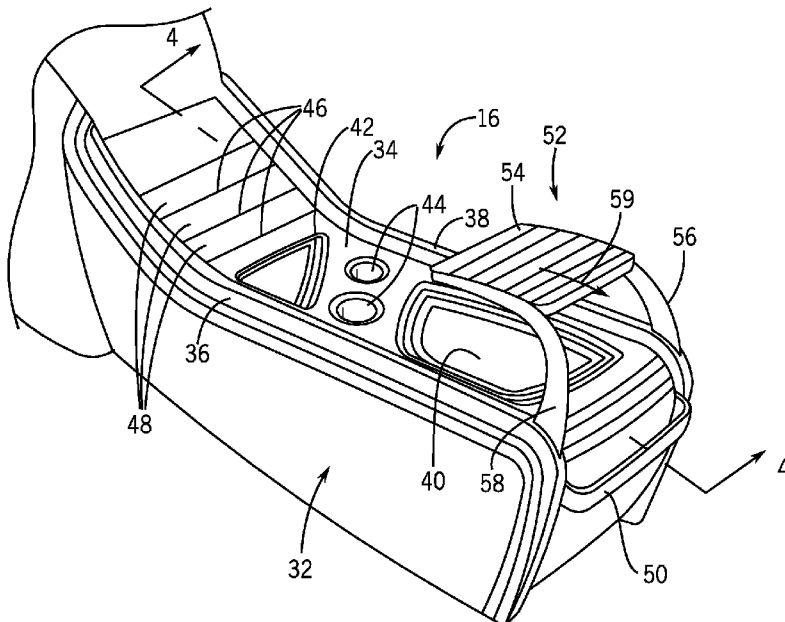

FIG. 3

(57) Abstract: A vehicle interior component 16,18,20,22,24,26,28 includes a support structure and a fabric panel 34 coupled to the support structure 32. The fabric panel 34 includes a recess configured to receive an object for storage, and the fabric panel 34 is formed from a continuous sheet of material knitted into a multi-dimensional shape to form the recess.



- (84) Designated States** (*unless otherwise indicated, for every kind of regional protection available*): ARIPO (BW, GH, GM, KE, LR, LS, MW, MZ, NA, RW, SD, SL, SZ, TZ, UG, ZM, ZW), Eurasian (AM, AZ, BY, KG, KZ, RU, TJ, TM), European (AL, AT, BE, BG, CH, CY, CZ, DE, DK, EE, ES, FI, FR, GB, GR, HR, HU, IE, IS, IT, LT, LU, LV, MC, MK, MT, NL, NO, PL, PT, RO, RS, SE, SI, SK, SM, TR), OAPI (BF, BJ, CF, CG, CI, CM, GA, GN, GQ, GW, KM, ML, MR, NE, SN, TD, TG).
- Published:**
- *with international search report (Art. 21(3))*
 - *before the expiration of the time limit for amending the claims and to be republished in the event of receipt of amendments (Rule 48.2(h))*

VEHICLE INTERIOR COMPONENT HAVING A MULTI-DIMENSIONAL KNITTED FABRIC PANEL

CROSS REFERENCE TO RELATED APPLICATION

[0001] This application claims priority from and the benefit of U.S. Provisional Patent Application Serial No. 61/826,173, entitled “VEHICLE INTERIOR COMPONENT HAVING A MULTI-DIMENSIONAL KNITTED FABRIC PANEL”, filed May 22, 2013, which is hereby incorporated by reference in its entirety.

BACKGROUND

[0002] The invention relates generally to vehicle interior components, and more specifically, to a vehicle interior component having a multi-dimensional knitted fabric panel.

[0003] Certain vehicle interior components (e.g., door panels, A-pillars, the instrument panel, the center console, etc.) include one or more fabric panels configured to establish a desirable visual appearance. Unfortunately, if a fabric panel is applied to a multi-dimensional surface (e.g., a surface having a compound curve), wrinkles or creases may form within the fabric panel, thereby detracting from the visual appearance. In addition, if the interior component includes a recess (e.g., a cup holder, a storage compartment, etc.), a separate storage bin (e.g., formed from plastic) may be employed. The aesthetic variation between the fabric panel and the separate storage bin may further reduce the visual appearance of the interior component.

BRIEF DESCRIPTION OF THE INVENTION

[0004] The present invention relates to a vehicle interior component including a support structure and a fabric panel coupled to the support structure. The fabric panel includes a recess configured to receive an object for storage, and the fabric panel is formed from a continuous sheet of material knitted into a multi-dimensional shape to form the recess.

[0005] The present invention also relates to a vehicle interior component including a support structure having a first member, a second member, and a hinge configured to facilitate rotation of the second member relative to the first member. The vehicle interior component also includes a fabric panel coupled to the first and second members. The fabric panel is formed from a continuous sheet of material knitted into a multi-dimensional shape that substantially covers the hinge.

[0006] The present invention further relates to a vehicle interior component including a support structure having an opening. The vehicle interior component also includes a fabric panel coupled to the support structure. The fabric panel is formed from a continuous sheet of material knitted into a multi-dimensional shape that includes at least one pleat, and the at least one pleat is configured to facilitate elongation of the fabric panel to cover at least a portion of the opening.

DRAWINGS

[0007] FIG. 1 is a perspective view of an exemplary vehicle that may include an interior component having a multi-dimensional knitted fabric panel.

[0008] FIG. 2 is a perspective view of a part of the interior of the vehicle of FIG. 1.

[0009] FIG. 3 is a perspective view of an embodiment of a floor console including a multi-dimensional knitted fabric panel.

[0010] FIG. 4 is a cross-sectional view of the floor console of FIG. 3, taken along line 4-4.

[0011] FIG. 5 is a perspective view of another embodiment of a floor console including an expandable storage compartment in a collapsed position.

[0012] FIG. 6 is a perspective view of the floor console of FIG. 5, in which the expandable storage compartment is in an expanded position.

[0013] FIG. 7 is a perspective view of an embodiment of an instrument panel having a removable storage container.

[0014] FIG. 8 is a perspective view of the instrument panel of FIG. 7, in which the removable storage container is removed from the instrument panel.

[0015] FIG. 9 is a perspective view of an embodiment of a floor console including a door configured to selectively cover a recess.

[0016] FIG. 10 is a side view of an embodiment of a door panel including a multi-dimensional knitted fabric panel.

[0017] FIG. 11 is a perspective view of an embodiment of a vehicle door having a multi-dimensional knitted fabric panel substantially covering a hinge.

[0018] FIG. 12 is a perspective view of an embodiment of a floor console, in which a multi-dimensional knitted fabric panel substantially covers a hinge.

[0019] FIG. 13 is a perspective view of the floor console of FIG. 12, in which a door is rotated into an open position.

[0020] FIG. 14 is a perspective view of a vehicle interior including multiple openings and multi-dimensional knitted fabric panels configured to selectively cover the openings.

[0021] FIG. 15 is a cross-sectional view of an embodiment of a storage assembly having a multi-dimensional knitted fabric panel, in which the storage assembly is removable from a retaining structure.

[0022] FIG. 16 is a cross-sectional view of an alternative embodiment of a storage assembly having a multi-dimensional knitted fabric panel positioned above a liquid containment assembly.

[0023] FIG. 17 is a top view of a further embodiment of a storage assembly having a multi-dimensional knitted fabric panel and flexible retaining features.

DETAILED DESCRIPTION

[0024] FIG. 1 is a perspective view of a motor vehicle 10 that may include an interior component having a multi-dimensional knitted fabric panel. As illustrated, the vehicle 10 includes an interior 12 having a seat 14, a floor console 16, and an instrument panel 18. As discussed in detail below, the seat 14, the floor console 16, the instrument panel 18, and/or other areas within the interior 12 may include a multi-dimensional knitted fabric panel configured to enhance the visual appearance of the component and/or to provide additional storage pockets/recesses within the component. For example, in certain embodiments, an interior component includes a support structure and a fabric panel coupled to the support structure. The fabric panel includes a recess configured to receive an object for storage. In addition, the fabric panel is formed from a continuous sheet of material, which is knitted into a multi-dimensional shape to form the recess. Because one or more fabric panels may be utilized to form multiple recesses throughout the interior component, the visual appearance of the interior component may be enhanced, as compared to interior components having storage compartments formed from a different material than the surrounding fabric surfaces.

[0025] FIG. 2 is a perspective view of a part of the interior 12 of the vehicle 10 of FIG. 1. As illustrated, the vehicle interior 12 includes multiple interior components, such as the floor console 16, the instrument panel 18, a center console 20, a door panel 22, a headliner 24, sun visors 26, and an overhead console 28. As discussed in detail below, certain interior components may include a support structure and a fabric panel coupled to the support structure. The fabric panel is formed from a continuous sheet of material, which is knitted into a multi-dimensional shape. For example, the floor console 16, the instrument panel 18, the center console 20, the door panel 22, the headliner 24, the sun visors 26, and/or the overhead console 28 may include a fabric panel having a recess configured to receive an object for storage. In such a configuration, the fabric panel is formed from a continuous sheet of material, which is knitted into a multi-dimensional shape to form the recess. In further embodiments, a fabric panel may be employed to cover a hinge assembly of an interior component. In such embodiments, the fabric panel is formed from a continuous sheet of material,

which is knitted into a multi-dimensional shape that substantially covers the hinge. In addition, a multi-dimensional knitted fabric panel may be utilized to cover an opening within an interior component, such as the sun roof opening 30. For example, the fabric panel may be formed from a continuous sheet of material, which is knitted into a multi-dimensional shape having one or more pleats. The pleats are configured to facilitate elongation of the fabric panel to cover at least a portion of the opening.

[0026] FIG. 3 is a perspective view of an embodiment of a floor console 16 including a multi-dimensional knitted fabric panel. As illustrated, the floor console 16 includes a support structure 32 and a fabric panel 34 coupled to the support structure 32. As discussed in detail below, the fabric panel 34 includes multiple recesses configured to receive respective objects for storage. The fabric panel 34 is formed from a continuous sheet of material, which is knitted into a multi-dimensional shape to form the recesses. Knitting a continuous sheet of material into a multi-dimensional shape involves particularly selecting, arranging, and/or knitting fibers into a sheet having the desired shape and dimensions. For example, the knitting process may be employed to form a continuous sheet of material having a two-dimensional (e.g., simple) curve, or a three-dimensional (e.g., compound) curve. In addition, the knitting process may be utilized to form multiple two-dimensional and/or three-dimensional curves within the continuous sheet of material, thereby establishing a desired multi-dimensional shape. In certain embodiments, the fibers may be formed from a substantially resilient material, thereby enabling expansion of the sheet.

[0027] In the illustrated embodiment, the support structure 32 includes a first support 36 and a second support 38, which are spaced apart from one another. As illustrated, the first and second supports 36 and 38 are substantially aligned with a longitudinal axis of the vehicle interior. However, it should be appreciated that in alternative embodiments, the supports may be arranged in other positions and/or orientations within the vehicle interior 12. As illustrated, the fabric panel 34 extends between the pair of supports. The tension of the fabric panel 34 between the supports may be particularly selected to establish a desired firmness of the fabric panel 34. For example, the tension of the fabric panel may be selected to support an object of a desired weight on the fabric panel without substantial deflection. As will be

appreciated, a variety of mounting techniques may be employed to couple the fabric panel 34 to the supports 36 and 38. For example, the fabric panel 34 may be secured to the supports 36 and 38 by multiple fasteners, by an adhesive layer, by an ultrasonic welding process, and/or by other suitable attachment processes and/or devices.

[0028] In the illustrated embodiment, the fabric panel 34 includes a first recess 40 configured to receive a larger object (e.g., shopping bag, purse, etc.) for storage and a second recess 42 configured to receive a smaller object (e.g., cellular phone, music player, sunglasses, etc.) for storage. The fabric panel 34 also includes a pair of recesses 44, each configured to receive a beverage container. The size of the beverage container recesses 44 may be particularly selected to accommodate beverage containers of a desired diameter. In addition, the fabric panel 34 includes multiple expandable recesses 46. As discussed in detail below, each recess 46 includes a corresponding pleat 48 that is configured to expand as an object is inserted into the recess 46, thereby enabling the recess to accommodate objects of various sizes. The fabric panel 34 also includes a slot 50 configured to receive another object for storage. For example, the slot 50 may be accessible from a rear seat, thereby providing a storage compartment for rear passengers.

[0029] As previously discussed, the fabric panel is formed from a continuous sheet of material, which is knitted into a multiple-dimensional shape to form the recesses. In certain embodiments, the fabric panel 34 is configured to maintain the multi-dimensional shape without external support. However, in alternative embodiments, various supports (e.g., ribs, wires, rigid layers, etc.) may be knitted into the continuous sheet of material and/or coupled to the fabric panel to provide a desired appearance and/or resistance to deformation. In certain embodiments, ribs may be coupled to the support structure to control movement of the fabric panel. For example, ribs may be positioned beneath the fabric panel 34 to block deflection of the fabric panel beyond a desired depth. In addition, ribs may be positioned on opposite longitudinal ends of each expandable recess 46, thereby controlling the width (i.e., longitudinal extent) of the recess 46. In certain embodiments, the ribs may be movable (e.g., in the longitudinal direction) relative to the support structure to adjust the width of each expandable recess, thereby enabling the recess to accommodate

objects of various dimensions. While the illustrated embodiment includes a larger recess 40, a smaller recess 42, two beverage container recesses 44 and three expandable recesses 46, it should be appreciated that alternative embodiments may include more or fewer recesses to provide the desired storage configuration for the vehicle occupants.

[0030] While each recess of the illustrated floor console 16 is formed from a single fabric panel 34, it should be appreciated that certain recesses may be formed from separate fabric panels in alternative embodiments. For example, in certain embodiments, the larger recess 40, the smaller recess 42, and the expandable recesses 46 may be formed from a first fabric panel, and each beverage container recess 44 may be formed from a respective second fabric panel. In such embodiments, the second fabric panels are coupled (e.g., stitched, adhesively coupled, welded, etc.) to the first fabric panel to form the complete fabric structure of the floor console. Such a configuration may reduce manufacturing costs, as compared to forming each recess from a single fabric panel 34.

[0031] In the illustrated embodiment, the floor console 16 includes an armrest 52 positioned above the support structure 32. As illustrated, the armrest 52 includes a second fabric panel 54, which is formed from a second continuous sheet of material. Similar to the fabric panel 34 described above, the second continuous sheet of material is knitted into a multi-dimensional shape to form the armrest 52. For example, the multi-dimensional shape may include multiple pleats configured to establish a desired visual appearance and/or to provide a desired resistance to deformation under load (e.g., from an occupant arm). In addition, the floor console 16 includes a first extension arm 56 and a second extension arm 58, each configured to support the armrest 52 above the support structure 32. The fabric panel 54 of the armrest 52 extends between the extension arms, and a tension of the fabric panel 54 between the extension arms may be particularly selected and/or adjustable to provide a desired firmness. In certain embodiments, the fabric panel 54 may include pleats configured to facilitate expansion of the armrest 52 in the direction 59. For example, the longitudinal extent of the fabric panel 54 may be adjusted by a vehicle occupant to extend the armrest 52 to a desired position.

[0032] In certain embodiments, the fabric panels 34 and 54 are removable from the floor console (e.g., to facilitate cleaning of the panels). For example, the fabric panel 34 may be detached from the supports 36 and 38 (e.g., by disengaging mechanical and/or hook-and-loop fasteners), thereby facilitating removal of the fabric panel 34. In certain embodiments, a second fabric panel 34 having a different configuration may be attached to the supports 36 and 38 after removal of the first fabric panel. Accordingly, the configuration of the floor console 16 may be adjusted based on occupant preference.

[0033] FIG. 4 is a cross-sectional view of the floor console of FIG. 3, taken along line 4-4. As illustrated, a first object (e.g., shopping bag, purse, etc.) 60 is disposed within the first recess 40. In the illustrated embodiment, at least a portion of the continuous sheet of material that forms the recess 40 is formed from resilient fibers. The resilient fibers are configured to facilitate expansion of the recess to accommodate heavier objects. For example, the weight of the first object 60 drives the resilient fibers to elongate, thereby inducing the first recess 40 to expand in the direction 61. Accordingly, the first recess 40 may accommodate objects of varying weights. Similarly, at least a portion of the continuous sheet of material that forms the second recess 42 may be formed from resilient fibers to accommodate objects (e.g., cellular phone, music player, sunglasses, etc.) 62 of varying weights.

[0034] In addition, a beverage container 64 is disposed within the beverage container recess 44. In the illustrated embodiment, at least a portion of the continuous sheet of material that forms the recess 44 is formed from resilient fibers. The resilient fibers are configured to facilitate expansion of the recess to accommodate objects having various sizes. For example, if the diameter of a beverage container 64 is larger than the diameter of the recess 44, the resilient fibers enable the recess to expand to accommodate the beverage container. In addition, the resilient fibers urge the fabric panel radially inward in the direction 65, thereby holding the beverage container 64 in place during operation of the vehicle.

[0035] Furthermore, another object 66 is inserted into an expandable recess 46. As previously discussed, the fabric panel 34 includes a pleat 48 positioned proximate to

each expandable recess 46. As illustrated, the pleat 48 expands as the object 66 is inserted into the recess 46, thereby enabling the recess 46 to accommodate objects of various sizes. As the object 66 is removed from the recess 46, the fabric panel returns to the original multi-dimensional shape, thereby reforming the pleat 48. In addition, the pleats may be utilized to retain objects, such as the object 68, that are placed on the surface of the fabric panel 34. As illustrated, another object 70, such as a tablet or notebook computer, is disposed within the slot 50.

[0036] Furthermore, in certain embodiments, at least a portion of the continuous sheet of material may be formed from electrically conductive fibers. In such embodiments, the fibers may transfer electrical energy from a power source to an electrically powered object coupled to the fabric panel. For example, in certain embodiments, the electrically conductive fibers may be employed to provide electrical power to a light source, thereby facilitating illumination (e.g., backlighting, accent lighting, spot lighting, etc.) of the fabric panel. In further embodiments, at least a portion of the continuous sheet of material may be formed from light transmissive fibers, thereby establishing a lighting effect throughout certain portions of the fabric panel. For example, fibers may be configured to establish distorted lighting patterns/colors as the fabric panel stretches to accommodate objects of various sizes and/or weights. Furthermore, in certain embodiments the continuous sheet of material may include anti-microbial fibers, integrated switches/buttons, and/or an integrated display.

[0037] FIG. 5 is a perspective view of another embodiment of a floor console 16 including an expandable storage compartment in a collapsed position. In the illustrated embodiment, the floor console 16 includes another fabric panel formed from a continuous sheet of material. Similar to the fabric panels described above, the continuous sheet of material is knitted into a multi-dimensional shape to form an expandable storage compartment 72. As illustrated, the expandable storage compartment 72 forms a substantially flush surface 74 with the support structure 32 while the expandable storage compartment 72 is in the illustrated collapsed position. However, when the expandable storage compartment 72 is expanded along the

direction 76, the fabric panel forms an open storage area (e.g., accessible by occupants of the rear seats) configured to receive and storage various items.

[0038] FIG. 6 is a perspective view of the floor console of FIG. 5, in which the expandable storage compartment 72 is in an expanded position. As illustrated, the expandable storage compartment 72 includes a fabric panel 78 having multiple pleats 79. The pleats 79 are formed by knitting a continuous sheet of material into a desired multi-dimensional shape. The pleats 79 facilitate expansion of the expandable storage compartment 72 from the collapsed position to the illustrated expanded position, thereby establishing an open storage area 80. In certain embodiments, the fabric panel 78 is configured to maintain the multi-dimensional shape of the expanded position until an occupant applies a force to the expandable storage compartment 72 in the direction 81, thereby urging the expandable storage compartment 72 toward the collapsed position. While in the collapsed position, a locking device (e.g., latch, lever, etc.) may hold the expandable storage compartment 72 in position until an occupant releases the locking device. Upon release of the locking device, the multi-dimensional shape of the fabric panel 78 may drive the expandable storage compartment 72 to expand in the direction 76 toward the expanded position.

[0039] FIG. 7 is a perspective view of an embodiment of an instrument panel 18 having a removable storage container. In the illustrated embodiment, the instrument panel 18 includes a glove compartment 82, and a removable storage container 84 is disposed within the glove compartment 82. The removable storage container 84 includes a fabric panel 86 formed from a continuous sheet of material. Similar to the embodiments described above, the continuous sheet of material is knitted into the multi-dimensional shape of the removable storage container 84. As illustrated, the removable storage container 84 is coupled to a door 88 of the glove compartment 82 and to an edge 90 of the instrument panel 18. Accordingly, with the glove compartment 82 in the illustrated open position, the removable storage container 84 forms an open storage area 91 within the glove compartment 82. The open storage area 91 may be utilized by vehicle occupants to store a variety of objects, such as maps, tools, glasses, and documents, among other items. To retain the objects within the removable storage container 84, the glove compartment door 88 may be moved

(e.g., rotated) in the direction 92 to a closed position. With the glove compartment door 88 in the closed position, objects within the removable storage container 84 are retained during operation of the vehicle.

[0040] In the illustrated embodiment, the removable storage container 84 may be removed from the glove compartment 82 while retaining the objects within the container. For example, with the glove compartment 82 in the illustrated open position, the removable storage container 84 may be extracted in the direction 94. In the illustrated embodiment, the removable storage container 84 includes a handle 96 that enables an occupant to grasp the container for extraction in the direction 94. After extraction of the removable storage container 84, each object within the container is removed from the glove compartment 82. As discussed in detail below, the open portion of the removable storage container 84 may be closed, thereby forming a contained storage area for retaining the objects while the container is removed from the glove compartment 82.

[0041] FIG. 8 is a perspective view of the instrument panel of FIG. 7, in which the removable storage container is removed from the instrument panel. As illustrated, the open portion of the removable storage container 84 is in a closed position, thereby forming a contained storage area within the container. In certain embodiments, the handle 96 may include a latching device configured to selectively hold the container in the closed position. For example, an occupant may extract the storage container 84 from the glove compartment 82 in the direction 94, and then latch the container into the closed position for storage and/or transportation of the objects within the storage container. To return the storage container to the glove compartment, the occupant may transition the container to the open position and then insert the open container into the glove compartment. While the removable storage container is configured to interface with a glove compartment in the illustrated embodiment, it should be appreciated that alternative embodiments may include removable storage containers configured to interface with other support structures within the vehicle interior. For example, in certain embodiments, the removable storage container may be configured to interface with a compartment within the overhead console, within the door panel, within the floor console, and/or within other components of the vehicle interior.

[0042] FIG. 9 is a perspective view of an embodiment of a floor console including a door configured to selectively cover a recess. In the illustrated embodiment, the floor console 16 includes a support structure 32 and a fabric panel 34 coupled to the support structure. The fabric panel 34 includes multiple recesses, each configured to receive a respective object for storage. Furthermore, the fabric panel 34 is formed from a continuous sheet of material knitted into a multi-dimensional shape to form the recesses. Similar to the embodiment described above with reference to FIGS. 3 and 4, the fabric panel 34 includes two beverage container recesses 44 and a slot 50 positioned proximate to a rearward end (e.g., an end facing rear seats) of the floor console 16. The fabric panel 34 also includes a first longitudinal recess 98 configured to receive an elongated object, such as a laptop computer, a tablet, a notebook, documents, and/or other items. The fabric panel 34 also includes a second longitudinal recess 100 configured to receive additional objects. In the illustrated embodiment, the floor console 16 includes a door 102 configured to selectively cover the second longitudinal recess 100, thereby establishing a contained storage area. For example, the door 102 may be a flexible door, such as a tambour door, configured to slide toward an open position in the direction 102. While in the open position, an occupant may place various objects in the recess 100 for storage. The occupant may then close the door, thereby securing the objects within the recess 100 during operation of the vehicle.

[0043] While the illustrated embodiment includes a tambour door 102, it should be appreciated that alternative embodiments may include other door configurations. For example, certain embodiments may include rigid doors configured to rotate and/or translate between the open and closed positions. In addition, while the door 102 is configured to selectively cover a longitudinal recess in the illustrated embodiment, it should be appreciated that the door may be configured to cover other recesses (e.g., the laterally oriented recess 50, the beverage container recesses 44, etc.) in alternative embodiment. Furthermore, while the door 102 is employed to selectively cover a recess within the floor console 16, it should be appreciated that a door may be employed to selectively cover recesses within other interior components of the vehicle, such as recesses within a door panel, within an instrument panel, within an

overhead console, and/or within other vehicle interior components. In certain embodiments, the door 102 may be formed from a continuous sheet of material knitted into a multi-dimensional shape that includes multiple pleats. In such embodiments, the pleats are configured to facilitate elongation of the door to cover at least a portion of the corresponding recess.

[0044] FIG. 10 is a side view of an embodiment of a door panel including a multi-dimensional knitted fabric panel. As illustrated, the door panel 22 includes a door panel frame 106 and a fabric panel 108. In the illustrated embodiment, the fabric panel 108 is formed from a continuous sheet of material, which is knitted into a multi-dimensional shape to form a door bolster 110. The fabric panel 108 also includes a recess 112 configured to receive an object for storage, such as a portable electronic device, documents, and/or other items. Similar to the embodiments described above, the recess 112 is formed by knitting the fabric panel 108 into the desired multi-dimensional shape. While the illustrated embodiment includes a linear recess 112, it should be appreciated that the recess may be formed into other shapes. For example, the fabric panel 108 may include a substantially circular recess to facilitate storage of a beverage container.

[0045] In the illustrated embodiment, the door panel 22 includes multiple support elements 114 positioned between the door panel frame 106 and the fabric panel 108. The support elements 114 are configured to establish respective raised portions 116 on a show surface 118 of the fabric panel 108, thereby providing a desirable visual appearance. The multi-dimensional shape of the fabric panel 108 may be particularly selected to accommodate the support elements 114. For example, the fabric panel 108 may include multiple troughs configured to receive the respective support elements 114. While the fabric panel 108 includes three elongated raised positions 116 in the illustrated embodiment, it should be appreciated that alternative embodiments may include more or fewer raised positions and/or raised positions having different shapes. For example, in certain embodiments, the fabric panel may include a circular, elliptical, or polygonal raised portion, and/or a raised portion extending about the perimeter of the fabric panel.

[0046] While the illustrated embodiment employs support elements 114 to establish the raised positions 116 on the show surface 118, it should be appreciated that the support elements 114 may be omitted in alternative embodiments. For example, in certain embodiments, the multi-dimensional shape of the fabric panel 108 may form the raised positions 116 via corresponding pleats. In such embodiments, the fabric panel 108 is configured to maintain the multi-dimensional shape of the raised portions 116 without external support (e.g., from the support elements 114). Accordingly, the manufacturing costs and/or the weight of the door panel may be reduced.

[0047] In the illustrated embodiment, the fabric panel 108 covers a speaker 120 within the door panel 22. Accordingly, the continuous sheet of material is configured to facilitate passage of acoustical energy through the fabric panel 108, thereby enabling vehicle occupants to hear sounds produced by the speaker 120. Because the speaker 120 is covered by the fabric panel 108, additional speaker covers may be obviated. As a result, vehicle manufacturing costs may be reduced, and/or the appearance of the vehicle interior may be enhanced.

[0048] Furthermore, the fabric panel 108 covers a vent 122 within the door panel 22. Accordingly, the continuous sheet of material is configured to facilitate passage of air through the fabric panel 108, thereby enabling the heating/air conditioning system to effectively heat/cool the vehicle interior. Because the vent 122 is covered by the fabric panel 108, molded vanes/controls (e.g., positioned on the door panel 22) may be obviated. As a result, vehicle manufacturing costs may be reduced, and/or the appearance of the vehicle interior may be enhanced.

[0049] FIG. 11 is a perspective view of an embodiment of a vehicle door having a multi-dimensional knitted fabric panel substantially covering a hinge. In the illustrated embodiment, the vehicle 10 includes a hinge assembly 124 configured to facilitate rotation of a vehicle door between an open position and a closed position. The hinge assembly 124 includes an exterior surface 126 of the vehicle structure, an interior surface 128 of the door, and a hinge 130 configured to facilitate rotation of the door relative to the vehicle structure. As illustrated, the fabric panel 132 is coupled to

the exterior surface 126 of the vehicle structure and to the interior surface 128 of the vehicle door. The fabric panel 132 is formed from a continuous sheet of material knitted into a multi-dimensional shape that substantially covers the hinge 130. Because the fabric panel 132 substantially covers the hinge 130, the visual appearance of the vehicle 10 may be substantially enhanced.

[0050] In the illustrated embodiment, the multi-dimensional shape of the fabric panel 132 includes multiple pleats 134. The pleats 134 are configured to expand and contract in response to rotation of the door. For example, as the door is rotated from a closed position to an open position, the fabric panel 132 may expand from a collapsed position between the surfaces 126 and 128 to an expanded position that substantially covers the hinge 130. In certain embodiments, at least a portion of the continuous sheet of material is formed from resilient fibers. The resilient fibers are configured to facilitate deformation of the multi-dimensional shape to accommodate rotation of the door. For example, the resilient fibers may enable the fabric panel to elongate as the door rotates from the closed position to the open position.

[0051] In certain embodiments, the fabric panel 132 is configured to block rotation of the door beyond the open position. For example, the maximum expansion of the fabric panel 132 (e.g., due to the pleats 134 and/or the resilient fibers) may be limited to a desired length, thereby limiting the open position of the door to a desired angle. As a result, a rotation limiting device within the hinge assembly may be obviated, thereby reducing the manufacturing costs and/or the weight of the hinge assembly.

[0052] FIG. 12 is a perspective view of an embodiment of a floor console, in which a multi-dimensional knitted fabric panel substantially covers a hinge. In the illustrated embodiment, the floor console 16 includes a door 136 configured to rotate about a hinge 138 in a direction 140. In certain embodiments, the door 136 may be padded and configured to serve as an armrest for vehicle occupants. As illustrated, a fabric panel 142 is coupled to the support structure 32 of the floor console 16 and to the door 136. Similar to the embodiment described above with reference to FIG. 11, the fabric panel 142 is formed from a continuous sheet of material, which is knitted into a multi-dimensional shape that substantially covers the hinge 138. Because the

fabric panel 142 substantially covers the hinge 138, the visual appearance of the vehicle interior may be substantially enhanced.

[0053] FIG. 13 is a perspective view of the floor console of FIG. 12, in which the door is rotated into an open position. In the illustrated embodiment, at least a portion of the continuous sheet of material is formed from resilient fibers. The resilient fibers are configured to facilitate deformation of the multi-dimensional shape to accommodate rotation of the door 136. Accordingly, the fabric panel 142 may appear taut while the door 136 is in the closed position and in the open position, thereby substantially reducing or eliminating the possibility of wrinkle formation within the fabric panel. As a result, the visual appearance of the floor console 16 may be substantially enhanced. While a multi-dimensional knitted fabric panel is employed to substantially cover a vehicle door hinge and a floor console door hinge in the illustrated embodiments, it should be appreciated that multi-dimensional knitted fabric panels may be employed to cover other hinges throughout the vehicle interior. For example, a multi-dimensional knitted fabric panel may cover a hinge within an instrument panel, within a center console, within an overhead console, within a door panel, and/or within other areas of the vehicle interior.

[0054] FIG. 14 is a perspective view of a vehicle interior 12 including multiple openings and multi-dimensional knitted fabric panels configured to selectively cover the openings. As illustrated, the vehicle interior 12 includes a door frame 144 having a window opening 146, and a fabric panel 148 is coupled to the door frame 144. The fabric panel 148 is formed from a continuous sheet of material, which is knitted into a multi-dimensional shape that includes multiple pleats 150. The pleats 150 are configured to facilitate elongation of the fabric panel 148 to cover at least a portion of the opening 146. For example, the fabric panel 148 may expand in the direction 152 from a collapsed position at the base of the window opening 146 to an expanded position, in which the fabric panel extends from the base to the top of the window opening. In the illustrated embodiment, the door frame 144 is configured to support a substantially transparent panel (e.g., window 154) within the window opening 146. Accordingly, with the fabric panel 148 in the expanded position, the fabric panel 148 may block at least a portion of the light through the window 154, thereby reducing the

light intensity within the vehicle interior. While the fabric panel 148 is configured to selectively cover a window 154 in the illustrated embodiment, it should be appreciated that the fabric panel may be configured to cover other substantially transparent panels within the vehicle interior (e.g., a moon roof, a rear window, a transparent divider, etc.).

[0055] In the illustrated embodiment, the vehicle interior 12 includes a storage compartment 156 formed within a rear ledge 158. As illustrated, the rear ledge 158 is positioned behind the rear seats 160 and includes an opening 161. The opening 161 is configured to facilitate access to an interior of the storage compartment 156. A fabric panel 162 is coupled to the rear ledge 158 and configured to cover at least a portion of the opening 161. Similar to the fabric panel 148 described above, the fabric panel 162 includes multiple pleats 164. The pleats 164 are configured to facilitate elongation of the fabric panel 162 to cover at least a portion of the opening 161. For example, the fabric panel 162 may expand in the direction 166 from a collapsed position at the base of the opening 161 (e.g., proximate to the rear seats 160) to an expanded position, in which the fabric panel extends from the base to a rearward extent of the opening. In alternative embodiments, the fabric panel may expand from a collapsed position at the rearward extent of the opening to the expanded position.

[0056] The vehicle interior 12 also includes a storage compartment 168 formed within a floor panel 170. As illustrated, the floor panel 170 is positioned forward of the rear seats 160 and includes an opening 172. The opening 172 is configured to facilitate access to an interior of the storage compartment 168. A fabric panel 174 is coupled to the floor panel 170 and configured to cover at least a portion of the opening 172. Similar to the fabric panel 162 described above, the fabric panel 174 includes multiple pleats 176. The pleats 176 are configured to facilitate elongation of the fabric panel 174 to cover at least a portion of the opening 172. For example, the fabric panel 174 may expand in the direction 178 from a collapsed position at the base of the opening 172 (e.g., remote to the rear seats 160) to an expanded position, in which the fabric panel extends from the base to a rearward extent of the opening (e.g., proximate to the rear seats). In alternative embodiments, the fabric panel may expand

from a collapsed position at the rearward extent of the opening to the expanded position.

[0057] In the illustrated embodiment, a multi-dimensional knitted fabric panel is employed to selectively cover an opening to a storage compartment within the rear ledge and an opening to a storage compartment within the floor panel. However, it should be appreciated that multi-dimensional knitted fabric panels may be employed to cover openings within other storage compartments throughout the vehicle interior. For example, in certain embodiments, a multi-dimensional knitted fabric panel may cover an opening to a storage compartment within a door panel, within an overhead console, within a floor console, within an instrument panel, and/or within other areas of the vehicle interior.

[0058] FIG. 15 is a cross-sectional view of an embodiment of a storage assembly 180 having a multi-dimensional knitted fabric panel 182, in which the storage assembly 180 is removable from a retaining structure 184. In the illustrated embodiment, the storage assembly 180 and the retaining structure 184 are elements of a vehicle interior component, such as the floor console. As illustrated, the storage assembly 180 includes a support structure 186 coupled to the fabric panel 182. The support structure 186 includes a first bezel 188 facing an interior of the vehicle interior component and a second bezel 190 facing the interior of the vehicle. In the illustrated embodiment, a peripheral edge 191 of the fabric panel 182 is disposed between the first bezel 188 and the second bezel 190. The bezels 188 and 190 are coupled to the fabric panel 182 (e.g., via an adhesive connection, via fasteners, etc.) to secure the fabric panel 182 to the support structure 186. In certain embodiments, a show surface 192 (e.g., a surface facing the interior of the vehicle) of the second bezel 190 may be selected to enhance the appearance of the storage assembly 180. For example, the show surface 192 may be painted (e.g., via an in-mold painting process, via hydrographic printing, etc.) to match and/or to complement the appearance of the vehicle interior. In addition, an applique may be applied to the show surface 192 to simulate a wood or metal appearance.

[0059] In the illustrated embodiment, the retaining structure 184 is configured to selectively retain the support structure 186 of the storage assembly 180. As illustrated, the retaining structure 184 includes a lip 193 extending about the periphery of the retaining structure 184 and configured to contact a bottom surface of the support structure 186, thereby supporting the storage assembly 180 within the vehicle interior component. In the illustrated embodiment, the storage assembly 180 may be removed from the retaining structure 184 by lifting the support structure 186 upwardly in the direction 194. Once the storage assembly 180 has been removed, the fabric panel 182 may be cleaned (e.g., to remove spilled liquid from a beverage container). In certain embodiments, the fabric panel 182 may be removable from the support structure 186 to facilitate cleaning. While the support structure 186 is coupled to the retaining structure 184 by a lip 193 in the illustrated embodiment, it should be appreciated that other suitable connection systems, such as fasteners, snaps, or interlocking components, among others, may be utilized in alternative embodiments.

[0060] As illustrated, the fabric panel 182 includes a first recess 196 configured to receive an object for storage. Similar to the embodiments described above with reference to FIGS. 3-4, the fabric panel 182 is formed from a continuous sheet of material knitted into a multi-dimensional shape to form the recess 196. In the illustrated embodiment, the multi-dimensional shape includes multiple pleats 198 configured to facilitate expansion of the recess 196 to accommodate objects having various sizes. The pleats 198 extend substantially circumferentially about the recess 196, thereby facilitating axial expansion of the recess 196 in the direction 200 (e.g., toward an interior of the vehicle interior component). In addition, the storage assembly 180 includes a substantially rigid support plate 202 positioned at a bottom 204 of the recess 196. The support plate 202 is configured to facilitate expansion of the recess 196 in response to an object contacting the support plate 202 and driving the support plate 202 downwardly in the direction 200 (e.g., by distributing the contact force across the bottom 204 of the recess 196). In certain embodiments, the fabric panel 182 may include an opening in the bottom 204 of the recess 196 (e.g., to reduce construction costs of the fabric panel 182). In such embodiments, the support

plate 202 may be coupled to the fabric panel 182 and positioned to cover the opening, thereby blocking passage of an object through the opening.

[0061] In the illustrated embodiment, the fabric panel 182 includes a second recess 206 positioned adjacent to the first recess 196. As illustrated, the multi-dimensional shape of the fabric panel 182 includes multiple pleats 208 configured to facilitate expansion of the recess 206 to accommodate objects having various sizes. The pleats 208 extend generally longitudinally along the recess 206, thereby facilitating expansion of the recess 206 in the radially outward direction 210 (e.g., toward the adjacent recesses). Accordingly, the recess 206 may accommodate beverage containers, and/or other objects, of various diameters. In addition, the storage assembly 180 includes a second substantially rigid support plate 212 positioned at a bottom 214 of the recess 206. The support plate 212 is configured to control the shape of the recess 206. For example, a support plate 212 having a larger diameter (e.g., in combination with the shape of the multi-dimensional fabric panel) may increase the diameter of the bottom 214, while a support plate 212 having a smaller diameter (e.g., in combination with the shape of the multi-dimensional fabric panel) may decrease the diameter of the bottom 214. As will be appreciated, the shape of the recess 206 may be particularly selected (e.g., by selecting a support plate 212 having a desired diameter, and/or by selecting a fabric panel having the desired shape) to accommodate objects (e.g., beverage containers) within a desired size range.

[0062] In the illustrated embodiment, the fabric panel 182 also includes a third recess 216 positioned adjacent to the second recess 206. As illustrated, the recess 216 includes a first portion 218 positioned adjacent to the opening and a second portion 220 positioned beneath the first portion 218. As illustrated, the multi-dimensional shape of the fabric panel 182 includes multiple first pleats 222 configured to facilitate expansion of the first portion 218 of the recess 216 to accommodate objects having various sizes. The first pleats 222 extend generally longitudinally along the first portion 218 of the recess 216, thereby facilitating expansion of the first portion 218 in the radially outward direction 210. Accordingly, the recess 216 may accommodate objects (e.g., beverage containers) of various diameters. In addition, the multi-dimensional shape of the fabric panel 182 includes multiple second pleats 224

configured to facilitate expansion of the second portion 220 of the recess 216 to accommodate objects having various sizes. The second pleats 224 extend substantially circumferentially about the second portion 220 of the recess 216, thereby facilitating axial expansion of the second portion 220 in the direction 200 (e.g., toward an interior of the vehicle interior component). Accordingly, the recess 216 may accommodate beverage containers, and/or other objects, having various lengths.

[0063] In the illustrated embodiment, the vehicle interior component includes a light source 226 positioned outwardly from an outer surface 228 of the fabric panel 182 and directed toward the first recess 196. As will be appreciated, the light source 226 may include any suitable device configured to emit light toward the first recess 196, such as a light-emitting diode (LED), an incandescent bulb, or a fluorescent bulb, among others. In the illustrated embodiment, the light source 226 is mounted to a support arm 230 which is coupled to the retaining structure 184. However, it should be appreciated that, in alternative embodiments, the light source 226 may be mounted at any suitable location within the vehicle interior component. For example, the light source 226 may be mounted remote from the first recess 196 and optically coupled to the first recess 196 by a light transmissive element (e.g., a light guide, a fiber optic cable, etc.).

[0064] In the illustrated embodiment, at least a portion of the fabric panel 182 is configured to facilitate passage of light 232 from the light source 226 to an interior 234 of the first recess 196. For example, the spacing between fibers of the fabric panel 182 may enable light 232 to pass through the fabric panel 182 into the interior 234 of the first recess 196. In the illustrated embodiment, the fabric panel 182 includes multiple light transmissive fibers 236 configured to facilitate the light passage from the light source 226 to the interior 234 of the first recess 196. As previously discussed, the light transmissive fibers 236 may be configured to establish distorted lighting patterns/colors as the fabric panel 182 stretches to accommodate objects of various sizes and/or weights. In addition, the light transmissive fibers 236 may be configured to facilitate illumination of the interior 234 of the first recess 196 with a desired color. For example, the light source 226 may emit “white” light, and the light transmissive fibers 236 may be tinted to provide a desired illumination color.

[0065] While a single light source is utilized to illuminate the first recess 196 in the illustrated embodiment, it should be appreciated that additional light sources (e.g., 2, 3, 4, 5, 6, or more) may be directed toward the first recess 196 in alternative embodiments. For example, light sources may be distributed axially and/or circumferentially along the first recess 196. Moreover, while the first recess 196 is illuminated in the illustrated embodiment, it should be appreciated that the second and third recesses may be illuminated in alternative embodiments. For example, one or more light sources may be positioned proximate to the second and third recesses and directed toward the respective recesses. Alternatively, or in addition, light may be directed toward each of the illuminated recesses from a remote light sources via a light transmissive element, such as a light guide or a fiber optic cable, among others.

[0066] FIG. 16 is a cross-sectional view of an alternative embodiment of a storage assembly 238 having a multi-dimensional knitted fabric panel 240 positioned above a liquid containment assembly. Similar to the embodiment described above with reference to FIG. 15, the storage assembly 238 is removable from a retaining structure 242. In the illustrated embodiment, the storage assembly 238 and the retaining structure 242 are elements of a vehicle interior component, such as the floor console. As illustrated, the storage assembly 238 includes a support structure 244 coupled to the fabric panel 240. The support structure 244 includes a first bezel 246 facing an interior of the vehicle interior component and a second bezel 248 facing the interior of the vehicle. In the illustrated embodiment, a peripheral edge 249 of the fabric panel 240 is disposed between the first bezel 246 and the second bezel 248. The bezels 246 and 248 are coupled to the fabric panel 240 (e.g., via an adhesive connection, via fasteners, etc.) to secure the fabric panel 240 to the support structure 244.

[0067] In the illustrated embodiment, the retaining structure 242 is configured to selectively retain the support structure 244 of the storage assembly 238. Similar to the embodiment described above with reference to FIG. 15, the storage assembly 238 may be removed from the retaining structure 242 by lifting the support structure 244 upwardly in the direction 250. Once the storage assembly 238 has been removed, the fabric panel 240 may be cleaned (e.g., to remove spilled liquid from a beverage

container). In certain embodiments, the fabric panel 240 may be selectively removable from the support structure 244 to facilitate cleaning.

[0068] As illustrated, the fabric panel 240 includes a first recess 252 configured to receive an object for storage. In the illustrated embodiment, the fabric panel 240 is formed from a continuous sheet of material knitted into a multi-dimensional shape to form the recess 252. The multi-dimensional shape includes multiple pleats 253 configured to facilitate expansion of the recess 252 to accommodate objects having various sizes. The pleats 253 extend substantially circumferentially about the recess 252, thereby facilitating axial expansion of the recess 252 in the direction 254 (e.g., toward an interior of the vehicle interior component). In the illustrated embodiment, the pleats 253 include a first set 256 of pleats, in which each pleat is configured to enable the recess 252 to expand a first elongation distance in the direction 254. In addition, the pleats 253 include a second set 258 of pleats, in which each pleat is configured to enable the recess 252 to expand a second elongation distance, different from the first elongation distance, in the direction 254. For example, each of the first set 256 of pleats may enable the first recess 252 to expand a greater distance in the downward direction 254 than each of the second set 258 of pleats. In addition, in certain embodiments, each of the first set 256 of pleats may have less resistance to elongation than each of the second set 258 of pleats.

[0069] By utilizing pleats configured to enable varying elongation distances and/or having varying resistances to elongation, expansion of the recess in the direction 254 may vary non-linearly with the weight of the object disposed within the recess. For example, lighter objects may expand the second set of pleats, thereby facilitating a smaller expansion of the recess, and heavier objects may expand the first and second sets of pleats, thereby facilitating a larger expansion of the recess. While the pleats configured to enable the larger expansion are positioned below the pleats configured to enable the smaller expansion in the illustrated embodiment, it should be appreciated that, in alternative embodiments, the pleats configured to enable the larger expansion may be positioned above and/or interleaved with the pleats configured to enable the smaller expansion. In addition, in certain embodiments, the fabric panel

may include a third set of pleats configured to enable the recess to expand a third elongation distance, different than the first and second elongation distances.

[0070] In the illustrated embodiment, the fabric panel 240 includes a second recess 260 positioned adjacent to the first recess 252. As illustrated, the multi-dimensional shape of the fabric panel 240 includes a first axial portion 262 of the recess 260 having a first diameter 264, a second axial portion 266 of the recess 260 having a second diameter 268, different than the first diameter 264, and a third axial portion 270 of the recess 260 having a third diameter 272, different than the first diameter 264 and the second diameter 268. Prior to expansion of the recess 260 in the direction 254, the axial portions are arranged concentrically within the recess 260. For example, the second portion 266 may be positioned radially inward from the first portion 262, and the third portion 270 may be positioned radially inward from the second portion 266. However, when an object is translated in the direction 254, contact between the object and a bottom surface 273 of the recess 260 drives the recess 260 to expand in the direction 254, as indicated by the phantom lines, thereby positioning the second portion 266 below the first portion 262, and the third portion 270 below the second portion 266. As a result of the downward expansion, the recess may accommodate taller and/or heavier objects (e.g., beverage containers). In addition, in the illustrated embodiment, the second portion 266 and the third portion 270 are expandable in the radial direction 274, as shown by the phantom lines, thereby enabling the recess to accommodate beverage containers, or other objects, having larger diameters.

[0071] While the illustrated recess 260 includes three axial portions, it should be appreciated that the recess may include more or fewer portions (e.g., 2, 3, 4, 5, 6, or more) in alternative embodiments. In addition, it should be appreciated that the multi-dimensional shape of the fabric panel may include pleats to facilitate axial and/or radial expansion of the recess 260. Moreover, the first recess 252 and/or the second recess 260 may include a substantially rigid support plate positioned at the bottom of the recess to facilitate axial expansion of the recess.

[0072] In the illustrated embodiment, the storage assembly 238 includes a liquid containment assembly 276 positioned below the fabric panel 240 and configured to block liquid flow into an interior 278 of the vehicle interior component. As illustrated, the liquid containment assembly 276 includes a substantially liquid-tight vessel 280 configured to capture liquid that may pass through the fabric panel 240, thereby substantially blocking liquid flow into the interior 278 of the vehicle interior component. The vessel 280 may be formed from any suitable material, such as metal (e.g., aluminum, steel, etc.) or a polymeric material (e.g., thermoplastic elastomer (TPE), polycarbonate (PC), polyethylene (PE), etc.). In the illustrated embodiment, the vessel 280 is coupled to the retaining structure 242 to secure the liquid containment assembly 276 within the vehicle interior component. In certain embodiments, the vessel 280 may be removably secured to the retaining structure (e.g., via a latch system, fasteners, etc.) to facilitate removal of the liquid containment assembly 276 from the retaining structure 242. Removing the liquid containment assembly 276 from the retaining structure 242 may enable a user to empty the vessel 280 of collected liquid and/or may facilitate cleaning of the vessel 280.

[0073] FIG. 17 is a top view of a further embodiment of a storage assembly 282 having a multi-dimensional knitted fabric panel 284 and flexible retaining features 286. Similar to the embodiments described above with reference to FIGS. 15-16, the storage assembly 282 includes a support structure 288 coupled to the fabric panel 284. The fabric panel 284 includes a recess 290 configured to receive an object 292 (e.g., a beverage container) for storage, and the fabric panel 284 is formed from a continuous sheet of material knitted into a multi-dimensional shape to form the recess 290. The flexible retaining features 286 are coupled to the support structure 288 and configured to block movement of an object 290 (e.g., a beverage container) disposed within the recess. For example, the flexible retaining features 286 may block movement of a first beverage container disposed within a first portion 294 of the recess, and/or the flexible retaining features 286 may block movement of a second beverage container disposed within a second portion 296 of the recess. In addition, if a larger object (e.g., having an area greater than the first portion 294 or the second portion 296) is translated toward the recess 290, the retaining features 286 may flex in response to

contact with the object, thereby enabling the larger object to be disposed within the recess 290. Accordingly, the storage assembly 282 may retain objects of various sizes.

[0074] In certain embodiments, the flexible retaining features 286 may be formed from a resilient material, such as thermoplastic elastomer (TPE), or another suitable material. In the illustrated embodiment, the flexible retaining features 286 are covered by the fabric panel 284. However, in alternative embodiments, the flexible retaining features may extend through the fabric panel and/or may be separated from the fabric panel (e.g., positioned above the fabric panel). While two flexible retaining features 286 are employed in the illustrated embodiment, it should be appreciated that more or fewer retaining features may be utilized in alternative embodiments. For example, in certain embodiments, the storage assembly 282 may include 1, 2, 3, 4, 5, 6, 7, 8, or more flexible retaining features. Moreover, it should be appreciated that the multi-dimensional shape of the fabric panel 284 may include at least one pleat configured to facilitate expansion of the recess 290 to accommodate objects having various sizes, and/or a substantially rigid support plate may be positioned at the bottom of the recess to facilitate axial expansion of the recess.

[0075] While only certain features and embodiments of the invention have been illustrated and described, many modifications and changes may occur to those skilled in the art (e.g., variations in sizes, dimensions, structures, shapes and proportions of the various elements, values of parameters (e.g., temperatures, pressures, etc.), mounting arrangements, use of materials, colors, orientations, etc.) without materially departing from the novel teachings and advantages of the subject matter recited in the claims. The order or sequence of any process or method steps may be varied or re-sequenced according to alternative embodiments. It is, therefore, to be understood that the appended claims are intended to cover all such modifications and changes as fall within the true spirit of the invention. Furthermore, in an effort to provide a concise description of the exemplary embodiments, all features of an actual implementation may not have been described (i.e., those unrelated to the presently contemplated best mode of carrying out the invention, or those unrelated to enabling the claimed invention). It should be appreciated that in the development of any such

actual implementation, as in any engineering or design project, numerous implementation specific decisions may be made. Such a development effort might be complex and time consuming, but would nevertheless be a routine undertaking of design, fabrication, and manufacture for those of ordinary skill having the benefit of this disclosure, without undue experimentation.

CLAIMS:

1. A vehicle interior component, comprising:
a support structure; and
a fabric panel coupled to the support structure, wherein the fabric panel comprises a recess configured to receive an object for storage, and the fabric panel is formed from a continuous sheet of material knitted into a multi-dimensional shape to form the recess.
2. The vehicle interior component of claim 1, wherein the support structure comprises a pair of supports spaced apart from one another, and the fabric panel extends between the pair of supports.
3. The vehicle interior component of claim 2, wherein the fabric panel comprises a pleat positioned proximate to the recess, and the pleat is configured to expand as the object is inserted within the recess.
4. The vehicle interior component of claim 2, comprising a second fabric panel formed from a second continuous sheet of material, wherein the second continuous sheet of material is knitted into a second multi-dimensional shape to form an armrest, and the armrest is supported above the support structure by a pair of extension arms.
5. The vehicle interior component of claim 1, wherein the fabric panel is removable from the support structure.
6. The vehicle interior component of claim 1, comprising a second fabric panel formed from a second continuous sheet of material, wherein the second continuous sheet of material is knitted into a second multi-dimensional shape to form an expandable storage compartment, and the expandable storage compartment is configured to form a substantially flush surface with the support structure while in a collapsed position and to provide an open storage area in an expanded position.

7. The vehicle interior component of claim 1, comprising a second fabric panel formed from a second continuous sheet of material, wherein the second continuous sheet of material is knitted into a second multi-dimensional shape to form a removable storage container, and the removable storage container is configured to form an open storage area while coupled to the support structure and to form a contained storage area while removed from the support structure.

8. The vehicle interior component of claim 1, comprising a door configured to selectively cover the recess.

9. The vehicle interior component of claim 1, wherein the support structure comprises a door panel frame, and the fabric panel is configured to form a door bolster on the door panel frame.

10. The vehicle interior component of claim 9, wherein the fabric panel comprises a raised portion on a show surface of the fabric panel.

11. The vehicle interior component of claim 10, comprising a support element positioned between the door panel frame and the fabric panel, wherein the support element is configured to establish the raised portion on the show surface of the fabric panel.

12. The vehicle interior component of claim 9, wherein the fabric panel is configured to cover a vent within the door panel, a speaker within the door panel, or a combination thereof, and the continuous sheet of material is configured to facilitate passage of air through the fabric panel, to facilitate passage of acoustical energy through the fabric panel, or a combination thereof.

13. The vehicle interior component of claim 1, wherein the fabric panel is configured to maintain the multi-dimensional shape without external support.

14. The vehicle interior component of claim 1, wherein at least a portion of the continuous sheet of material is formed from resilient fibers, and the resilient fibers are configured to facilitate expansion of the recess to accommodate objects having various sizes.

15. The vehicle interior component of claim 1, comprising a retraining structure configured to selectively retain the support structure, wherein the support structure is removable from the retaining structure.

16. The vehicle interior component of claim 1, wherein the multi-dimensional shape includes at least one pleat configured to facilitate expansion of the recess to accommodate objects having various sizes.

17. The vehicle interior component of claim 16, wherein the at least one pleat comprises a first pleat configured to facilitate expansion of the recess in an axial direction, a second pleat configured to facilitate expansion of the recess in a radial direction, or a combination thereof.

18. The vehicle interior component of claim 16, wherein the at least one pleat comprises a first pleat configured to enable the recess to expand a first elongation distance and a second pleat configured to enable the recess to expand a second elongation distance, and the first elongation distance is different than the second elongation distance.

19. The vehicle interior component of claim 1, comprising a substantially rigid support plate positioned at a bottom of the recess.

20. The vehicle interior component of claim 1, comprising a plurality of flexible retaining features coupled to the support structure and configured to block movement of an object disposed within the recess.

21. The vehicle interior component of claim 1, comprising a liquid containment assembly positioned below the fabric panel and configured to block liquid flow into an interior of the vehicle interior component.

22. The vehicle interior component of claim 1, comprising a light source positioned outwardly from an outer surface of the fabric panel, wherein at least a portion of the fabric panel is configured to facilitate light passage from the light source to an interior of the recess.

23. The vehicle interior component of claim 22, wherein the fabric panel comprises a plurality of light transmissive fibers configured to facilitate the light passage from the light source to the interior of the recess.

24. The vehicle interior component of claim 1, wherein the multi-dimensional shape comprises a first axial portion of the recess having a first diameter and a second axial portion of the recess having a second diameter, different than the first diameter.

25. A vehicle interior component, comprising:

a support structure having a first member, a second member, and a hinge configured to facilitate rotation of the second member relative to the first member; and

a fabric panel coupled to the first and second members, wherein the fabric panel is formed from a continuous sheet of material knitted into a multi-dimensional shape that substantially covers the hinge.

26. The vehicle interior component of claim 25, wherein the multi-dimensional shape includes at least one pleat configured to expand and contract in response to rotation of the second member.

27. The vehicle interior component of claim 25, wherein at least a portion of the continuous sheet of material is formed from resilient fibers, and the resilient

fibers are configured to facilitate deformation of the multi-dimensional shape to accommodate rotation of the second member.

28. A vehicle interior component, comprising:

a support structure having an opening; and

a fabric panel coupled to the support structure, wherein the fabric panel is formed from a continuous sheet of material knitted into a multi-dimensional shape that includes at least one pleat, and the at least one pleat is configured to facilitate elongation of the fabric panel to cover at least a portion of the opening.

29. The vehicle interior component of claim 28, wherein the support structure comprises a storage compartment, and the opening facilitates access to an interior of the storage compartment.

30. The vehicle interior component of claim 28, wherein the support structure is configured to support a substantially transparent panel within the opening.

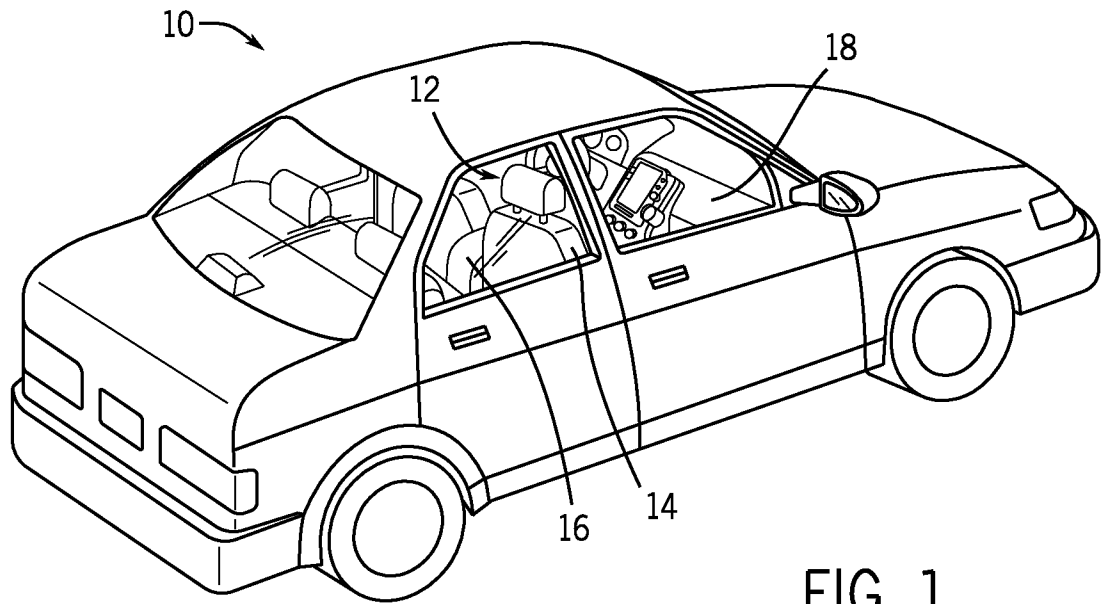

FIG. 1

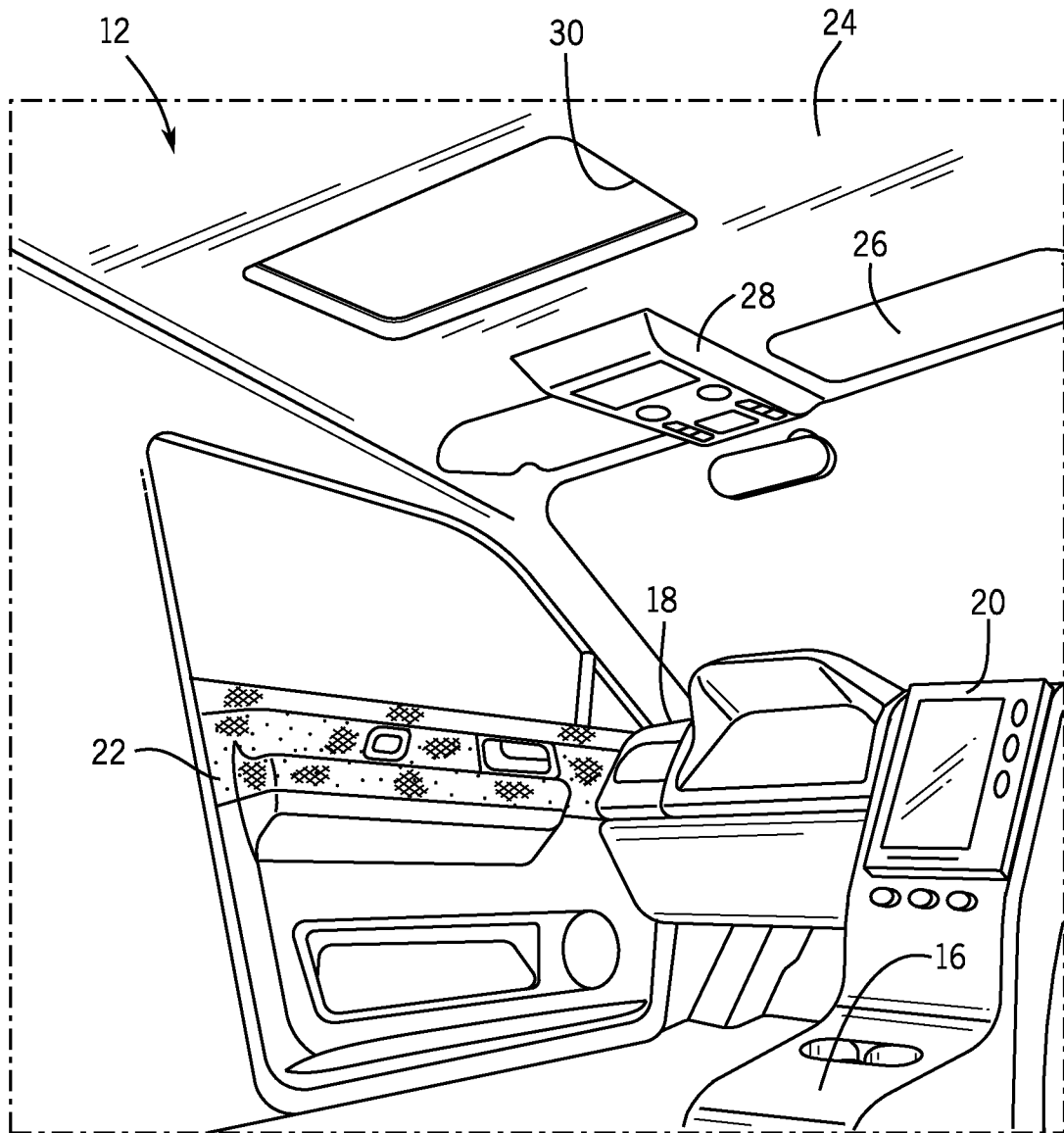

FIG. 2

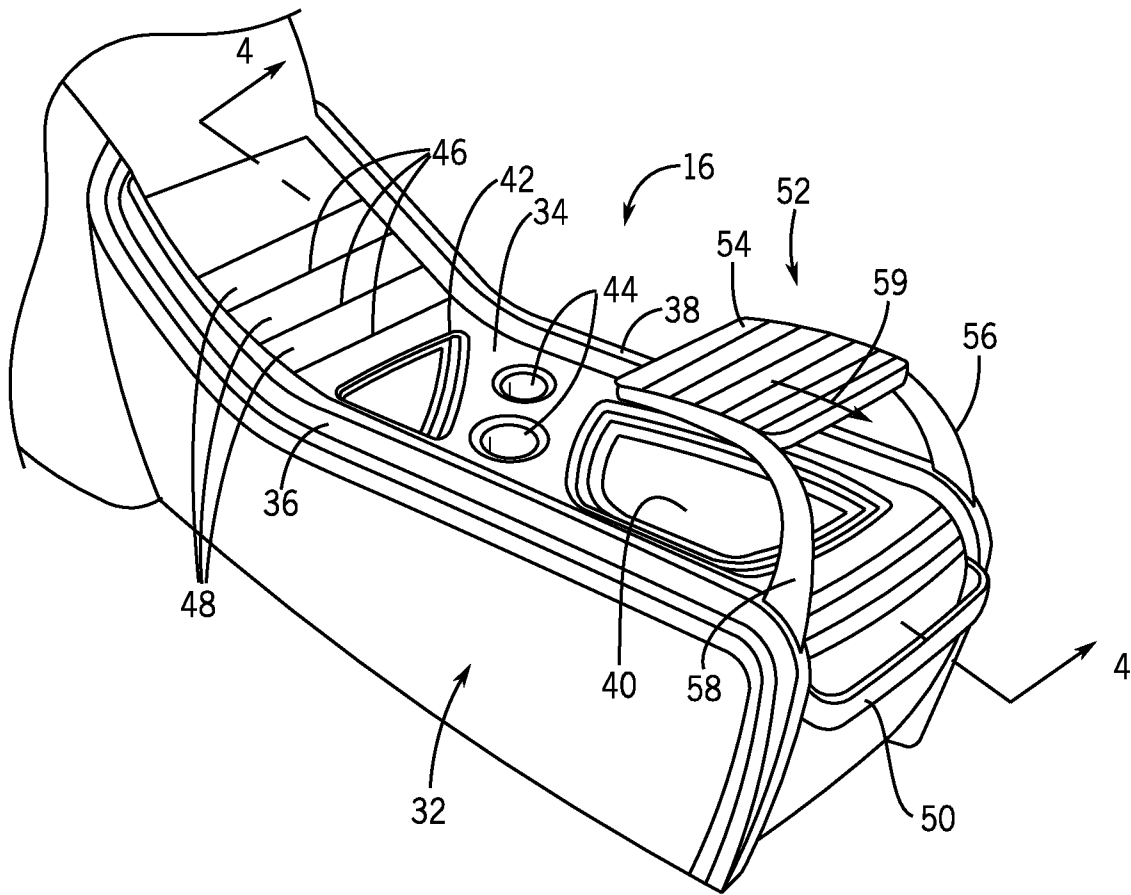

FIG. 3

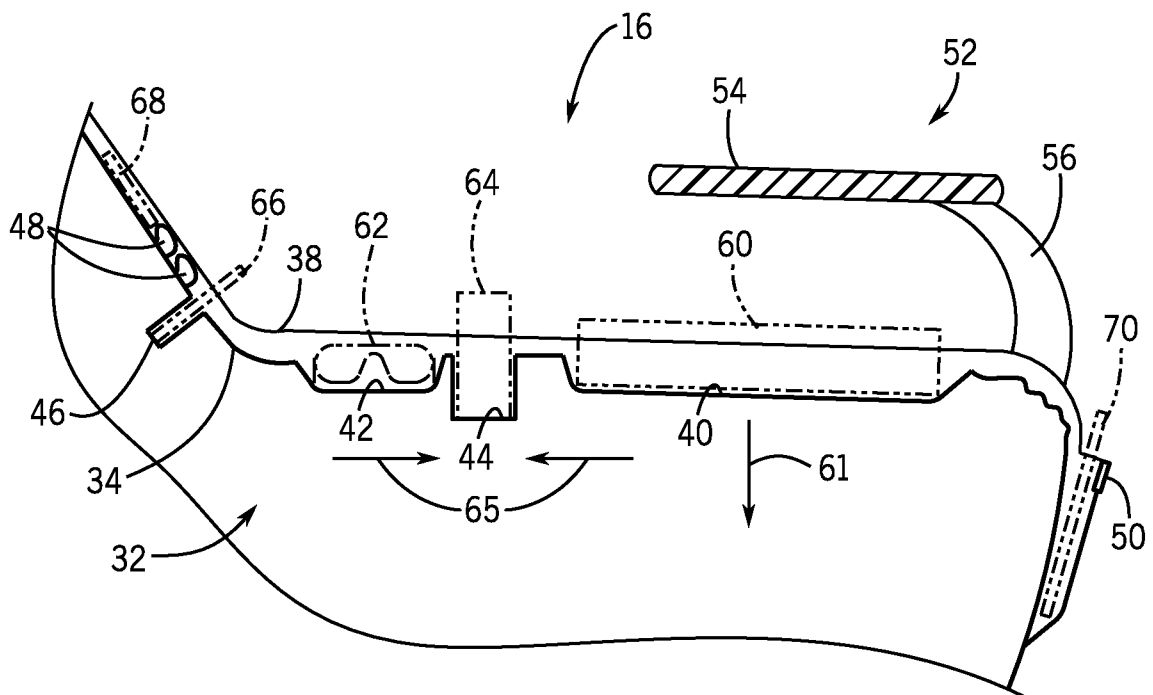
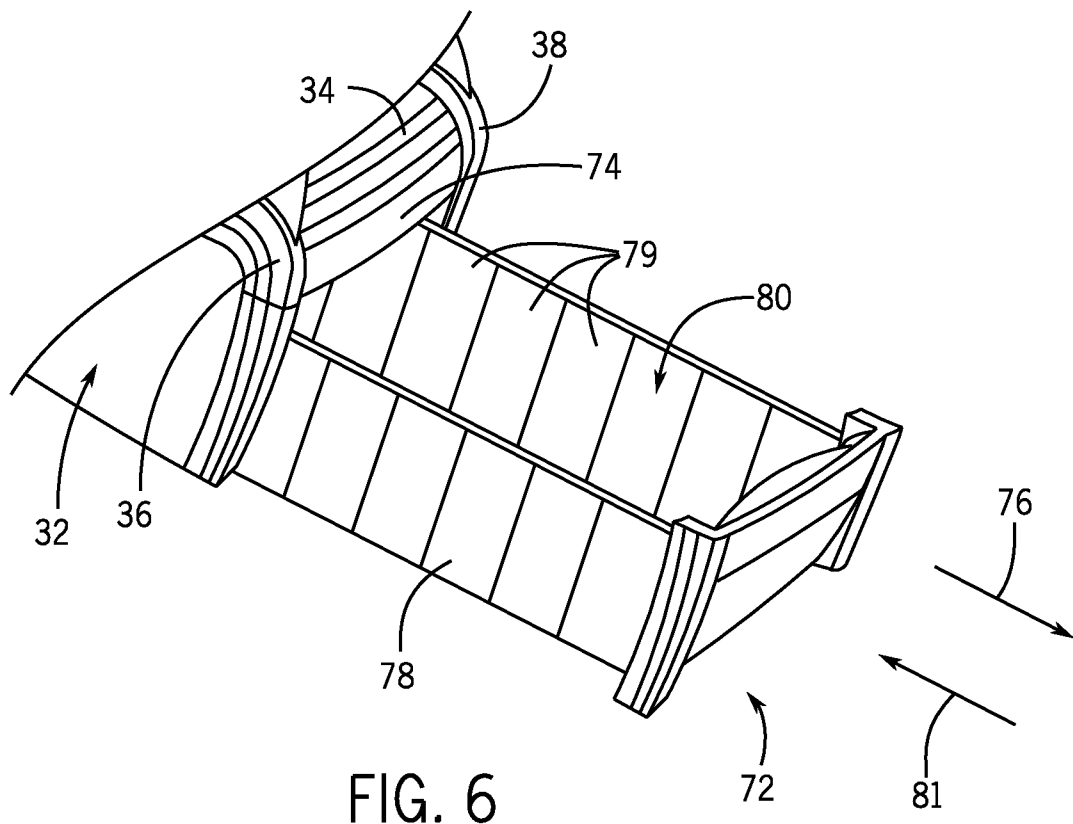
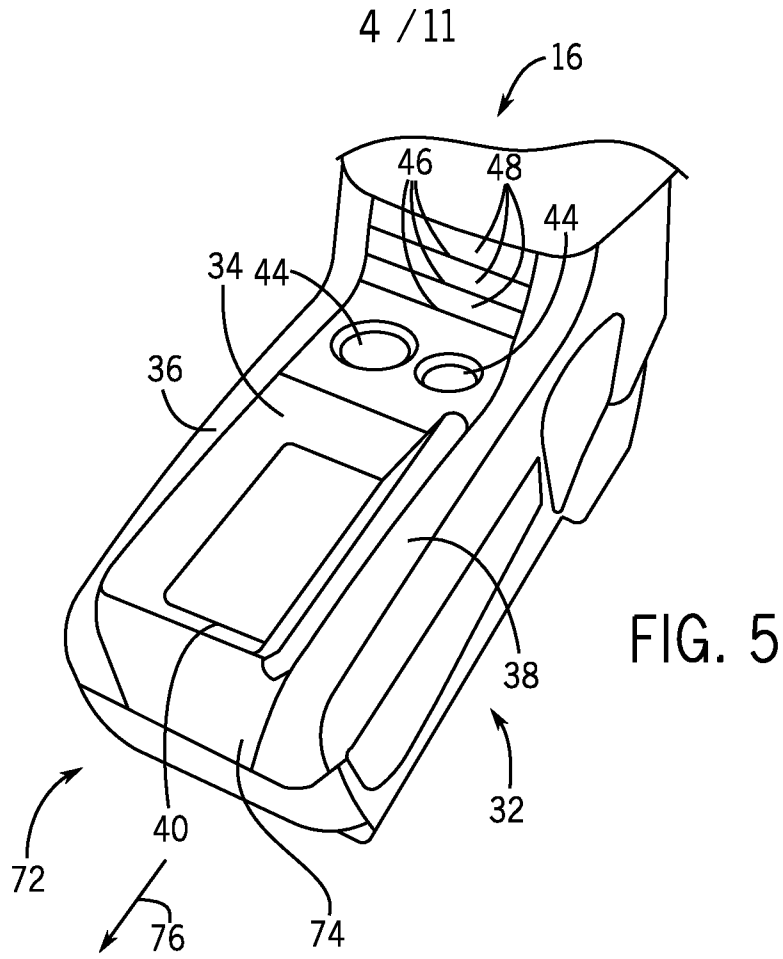

FIG. 4



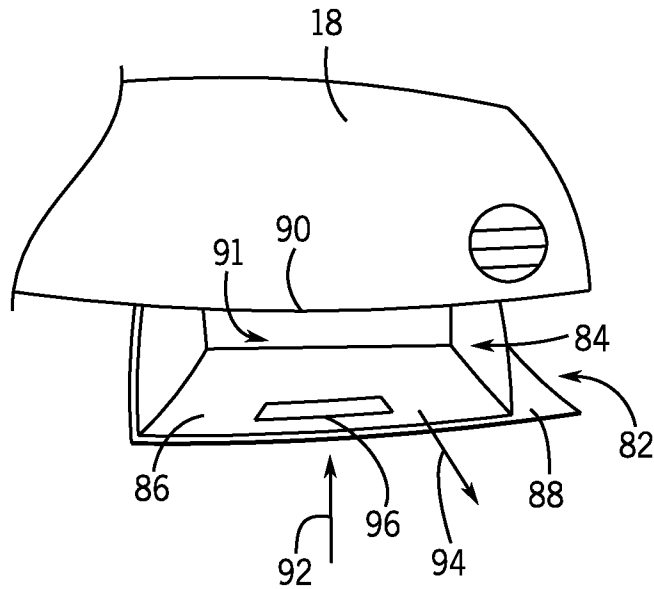

FIG. 7

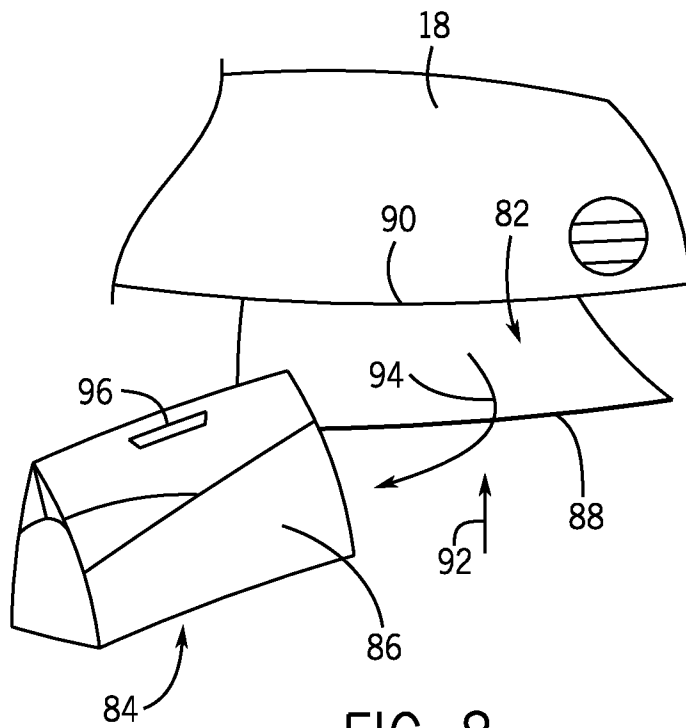

FIG. 8

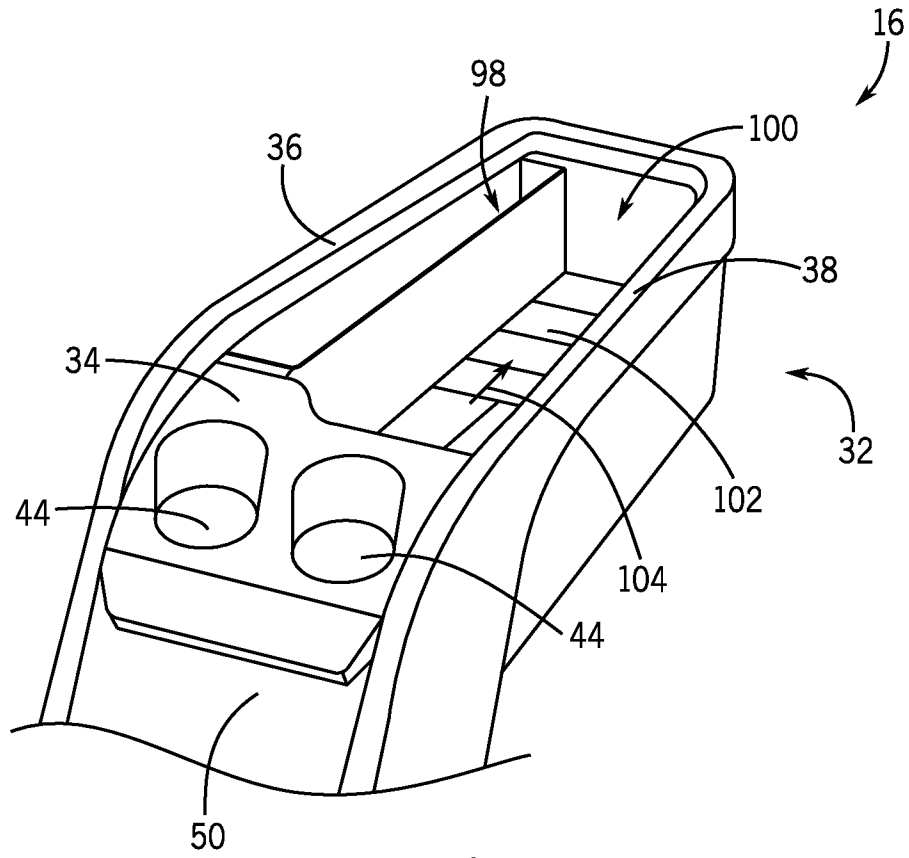

FIG. 9

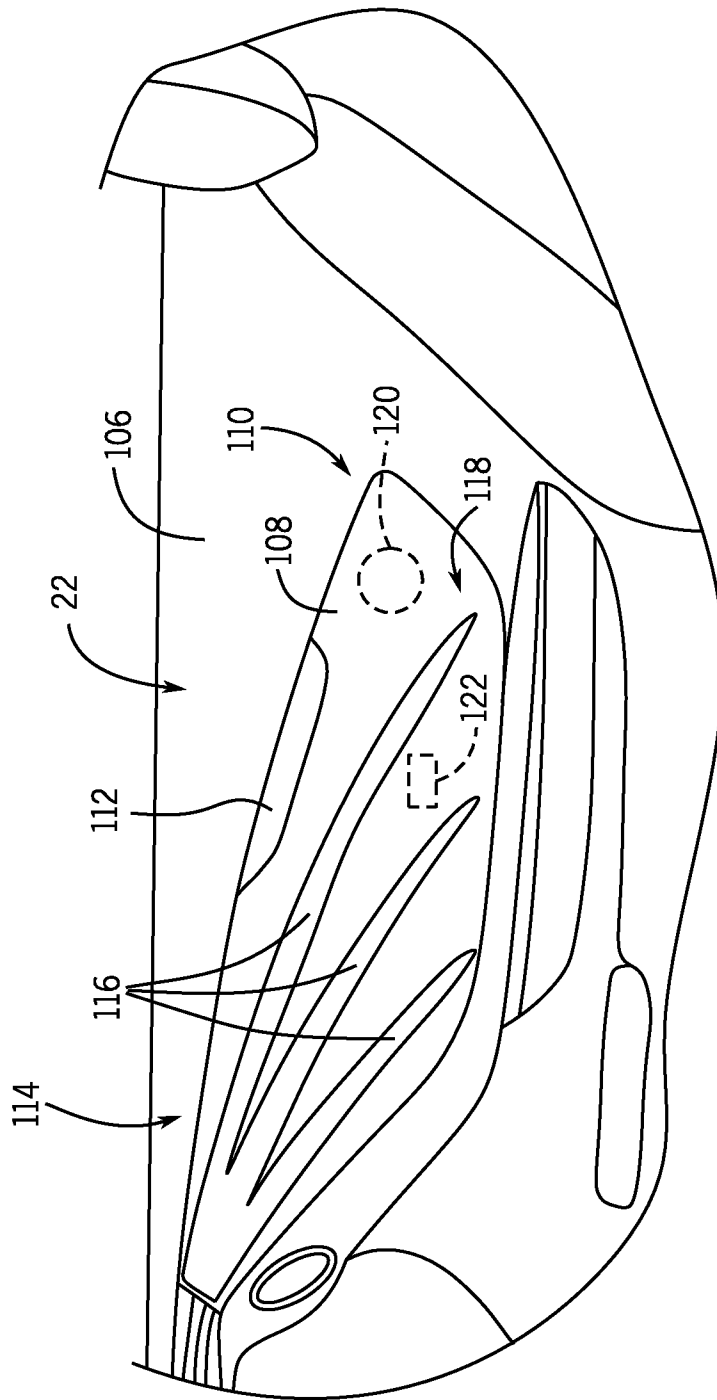

FIG. 10

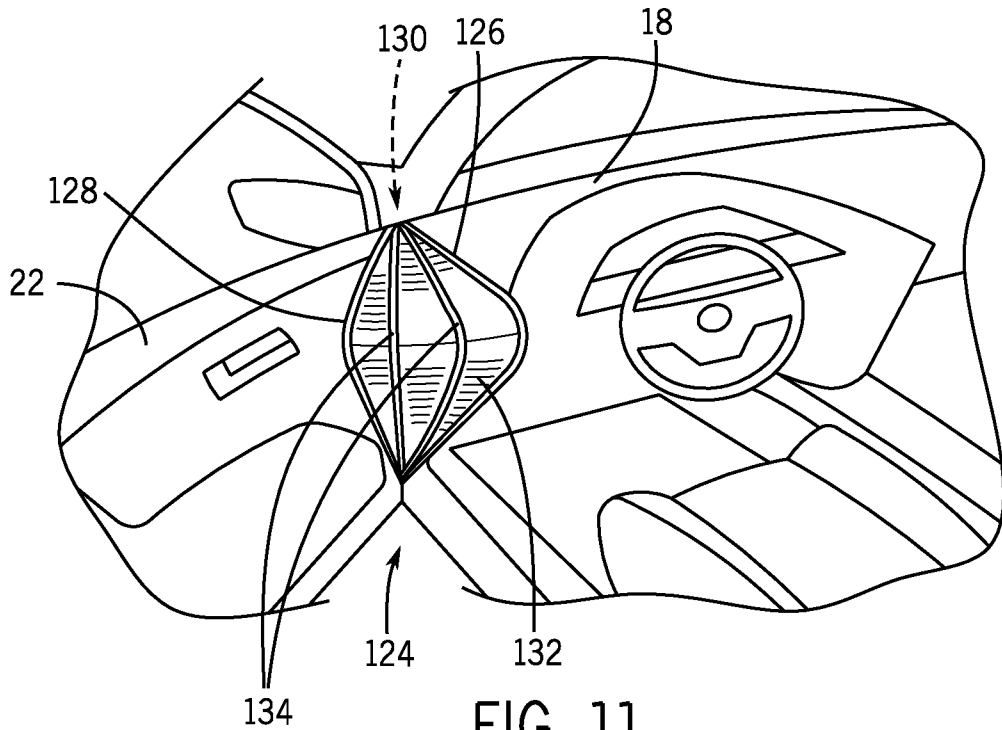

FIG. 11

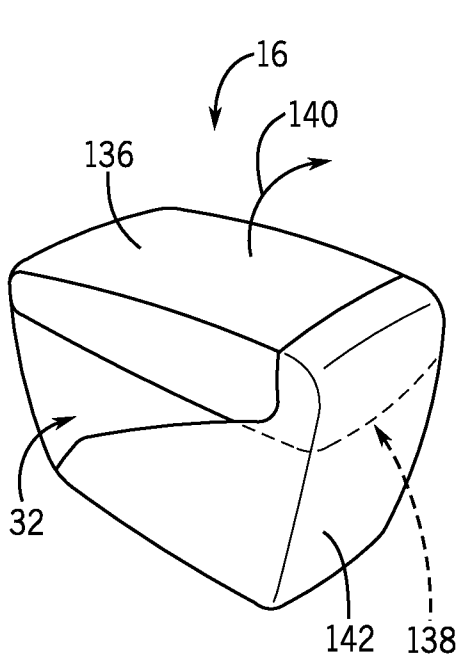

FIG. 12

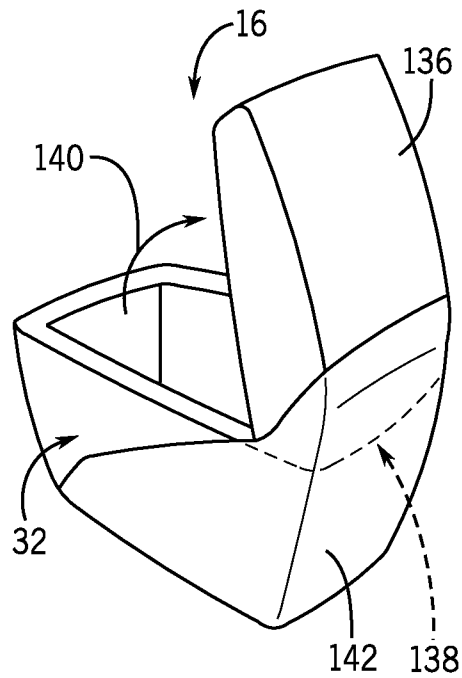

FIG. 13

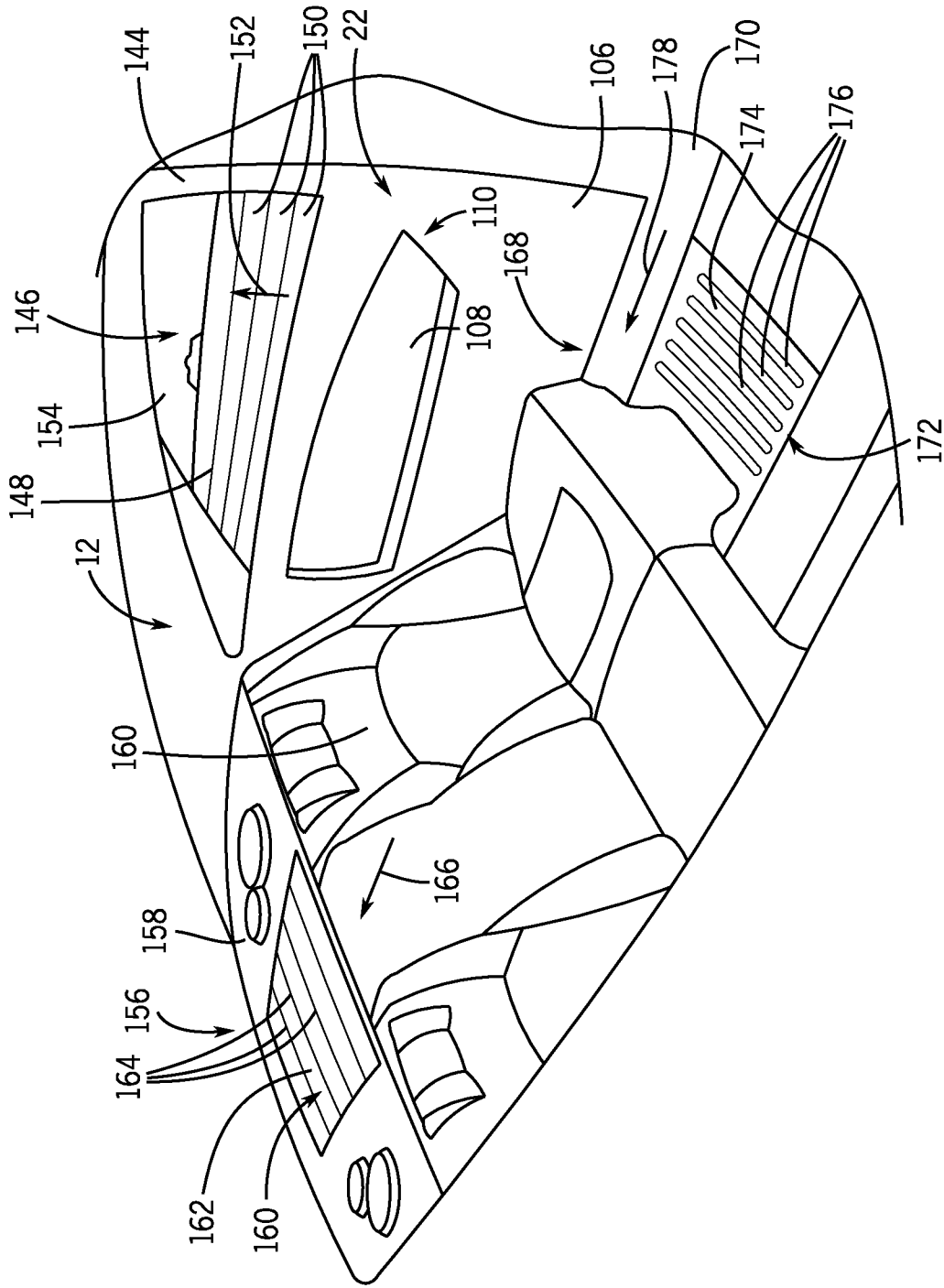

FIG. 14

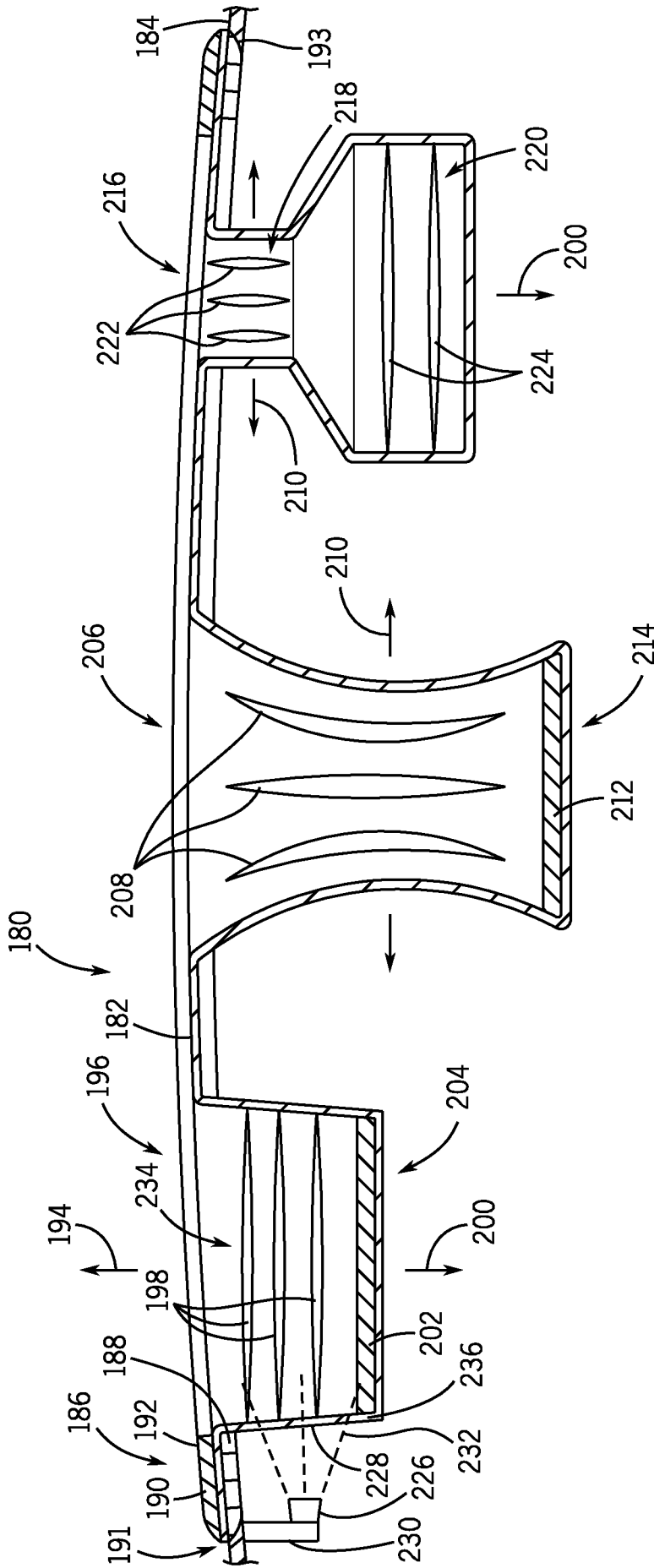

FIG. 15

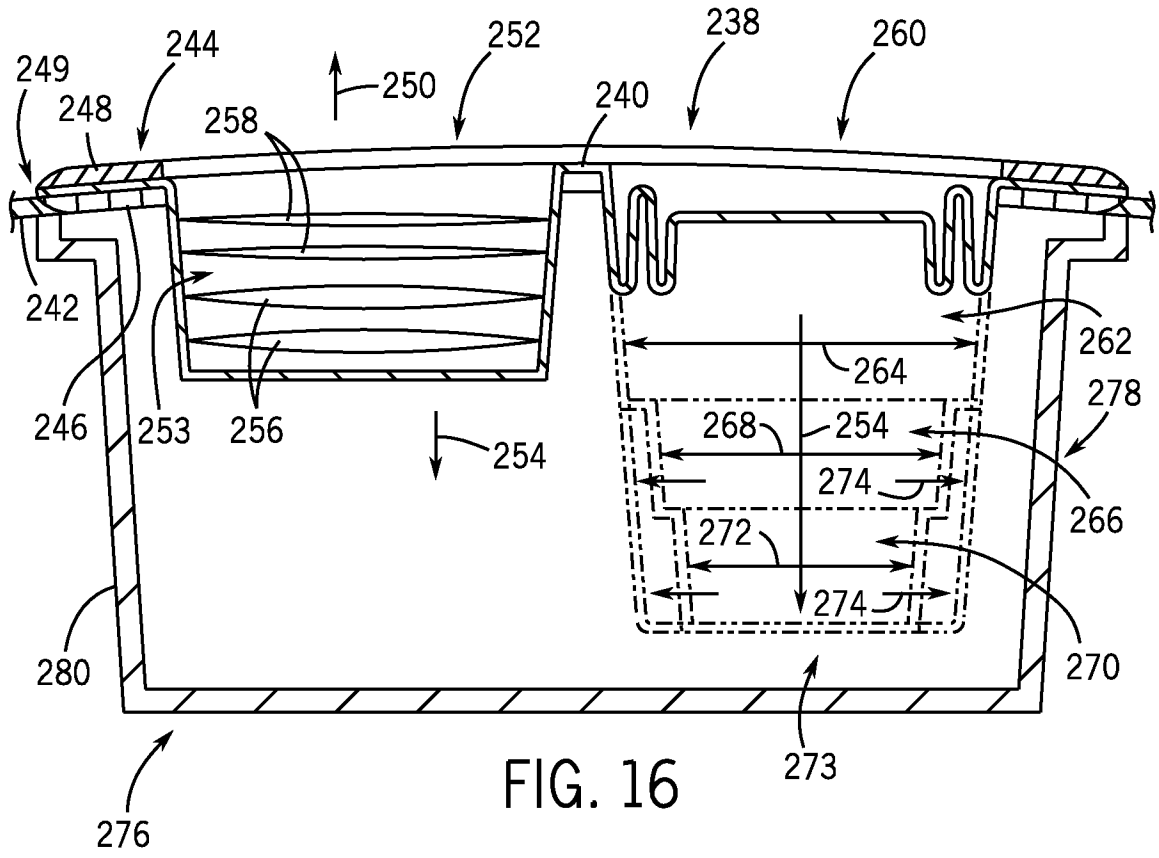

FIG. 16

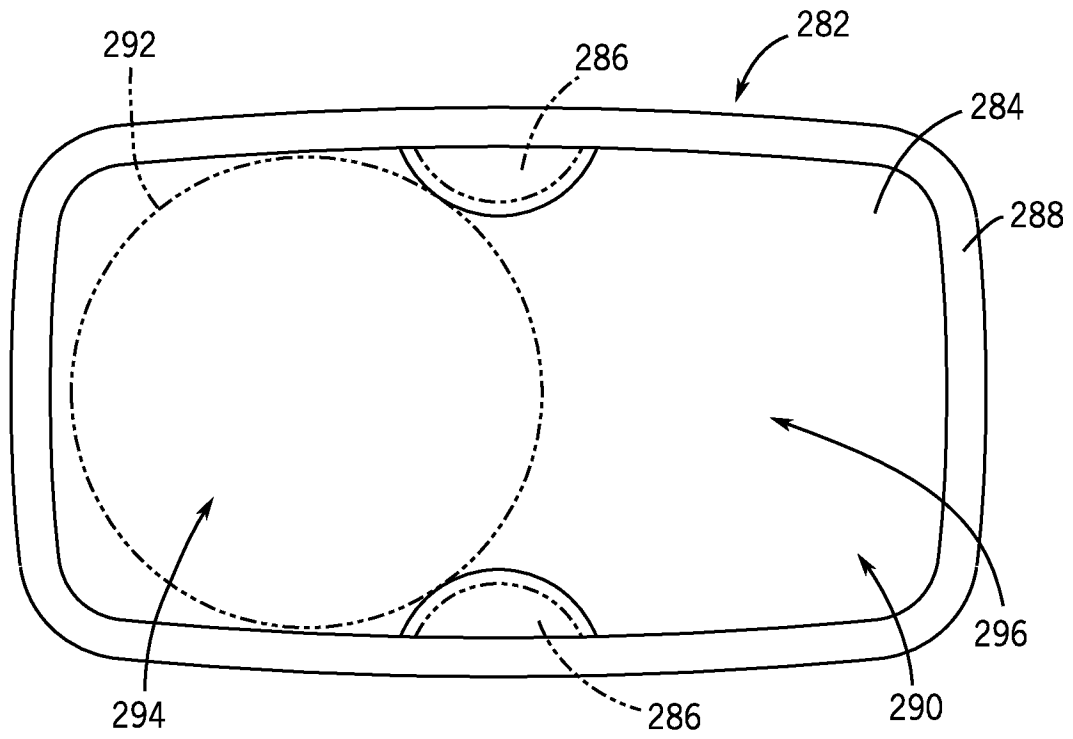

FIG. 17

INTERNATIONAL SEARCH REPORT

International application No
PCT/US2014/039224

A. CLASSIFICATION OF SUBJECT MATTER
INV. B60R13/02
ADD.

According to International Patent Classification (IPC) or to both national classification and IPC

B. FIELDS SEARCHED
Minimum documentation searched (classification system followed by classification symbols)
B60R B29C

Documentation searched other than minimum documentation to the extent that such documents are included in the fields searched

Electronic data base consulted during the international search (name of data base and, where practicable, search terms used)
EPO-Internal, WPI Data

C. DOCUMENTS CONSIDERED TO BE RELEVANT

Category*	Citation of document, with indication, where appropriate, of the relevant passages	Relevant to claim No.
X	WO 2004/087464 A1 (JOHNSON CONTR INTERIORS GMBH [DE]; SCHIDAN ALEXANDER [DE]; MIEGLITZ HA) 14 October 2004 (2004-10-14) page 6, line 12 - line 32 page 9, line 18 - line 33; figure 6 -----	1,5-11, 13-16, 19-30
X	US 4 002 520 A (FENTON SIDNEY DESMOND) 11 January 1977 (1977-01-11) figure 4 -----	1,25,28
X	DE 100 28 109 A1 (SUMITOMO CHEMICAL CO [JP]) 21 December 2000 (2000-12-21) column 1, line 8 - line 15 column 3, line 11 - line 34; figure 3 -----	1,25,28
E	WO 2014/110413 A1 (JOHNSON CONTROLS TECH CO [US]) 17 July 2014 (2014-07-17) claims 1-6; figure 1 -----	1,25,28

Further documents are listed in the continuation of Box C.

See patent family annex.

* Special categories of cited documents :

- "A" document defining the general state of the art which is not considered to be of particular relevance
- "E" earlier application or patent but published on or after the international filing date
- "L" document which may throw doubts on priority claim(s) or which is cited to establish the publication date of another citation or other special reason (as specified)
- "O" document referring to an oral disclosure, use, exhibition or other means
- "P" document published prior to the international filing date but later than the priority date claimed

- "T" later document published after the international filing date or priority date and not in conflict with the application but cited to understand the principle or theory underlying the invention
- "X" document of particular relevance; the claimed invention cannot be considered novel or cannot be considered to involve an inventive step when the document is taken alone
- "Y" document of particular relevance; the claimed invention cannot be considered to involve an inventive step when the document is combined with one or more other such documents, such combination being obvious to a person skilled in the art
- "&" document member of the same patent family

Date of the actual completion of the international search

17 September 2014

Date of mailing of the international search report

26/09/2014

Name and mailing address of the ISA/

European Patent Office, P.B. 5818 Patentlaan 2
NL - 2280 HV Rijswijk
Tel. (+31-70) 340-2040,
Fax: (+31-70) 340-3016

Authorized officer

Scheuer, Jürgen

INTERNATIONAL SEARCH REPORT

Information on patent family members

International application No

PCT/US2014/039224

Patent document cited in search report	Publication date	Patent family member(s)	Publication date
WO 2004087464	A1	14-10-2004	DE 10315653 A1
			WO 2004087464 A1

US 4002520	A	11-01-1977	AU 5198673 A
			BE 795274 A1
			DE 2306836 A1
			ES 411506 A1
			FR 2171813 A5
			GB 1402554 A
			IT 977285 B
			JP S4889078 A
			JP S5526876 B2
			SE 382907 B
			US 4002520 A
			ZA 7300861 A

DE 10028109	A1	21-12-2000	DE 10028109 A1
			JP 4186312 B2
			JP 2000343547 A
			MY 120846 A
			US 6616879 B1

WO 2014110413	A1	17-07-2014	NONE
