

A. RUTHENBERG.
EXTENSION LADDER TRUCK.

No. 524,047.

Patented Aug. 7, 1894.

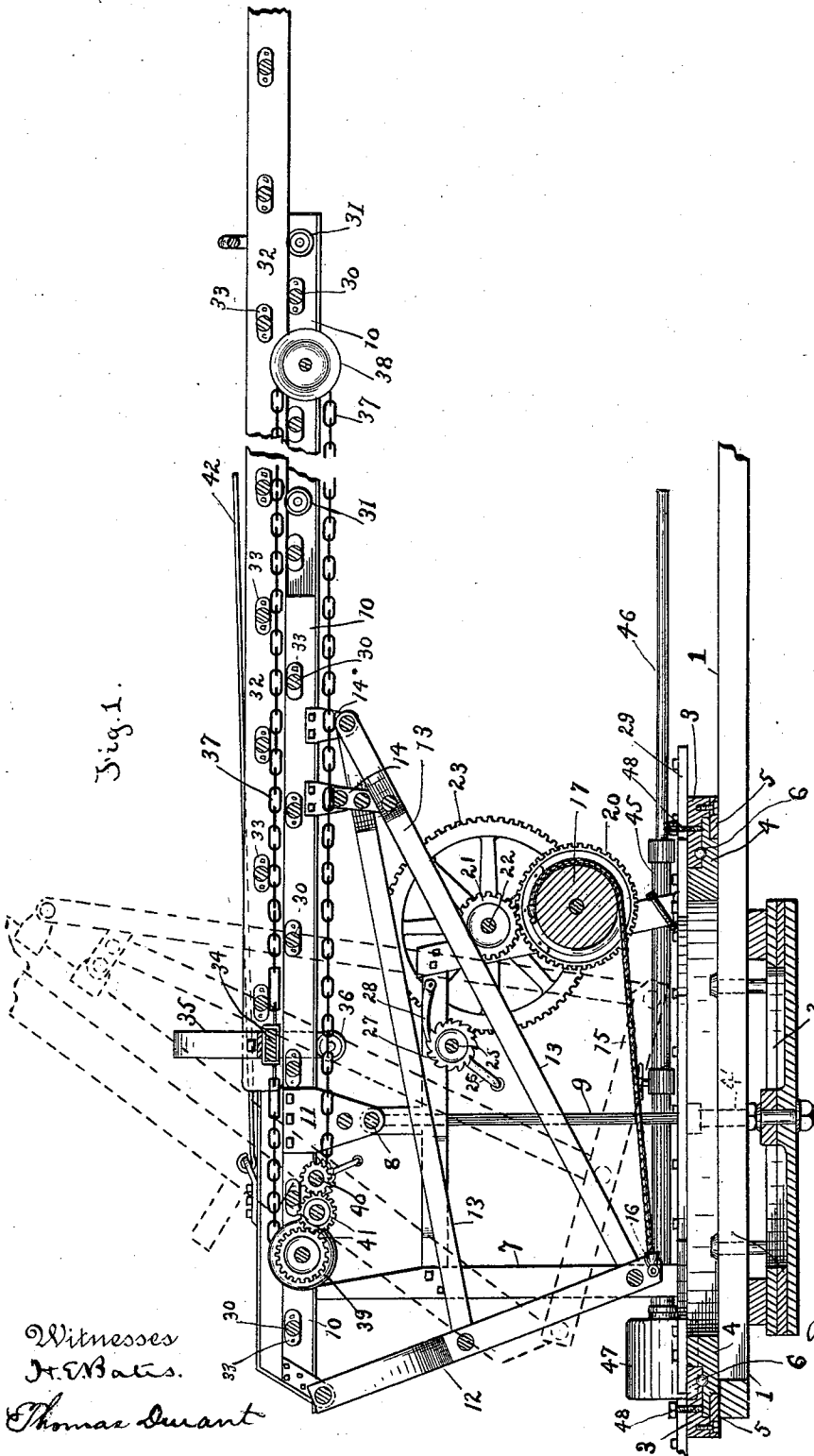

Fig. 1.

Witnesses
H. E. Bates.
Thomas Durant

Inventor
August Ruthenberg
Church & Church
his Attorneys

A. RUTHENBERG. EXTENSION LADDER TRUCK.

No. 524,047.

Patented Aug. 7, 1894.

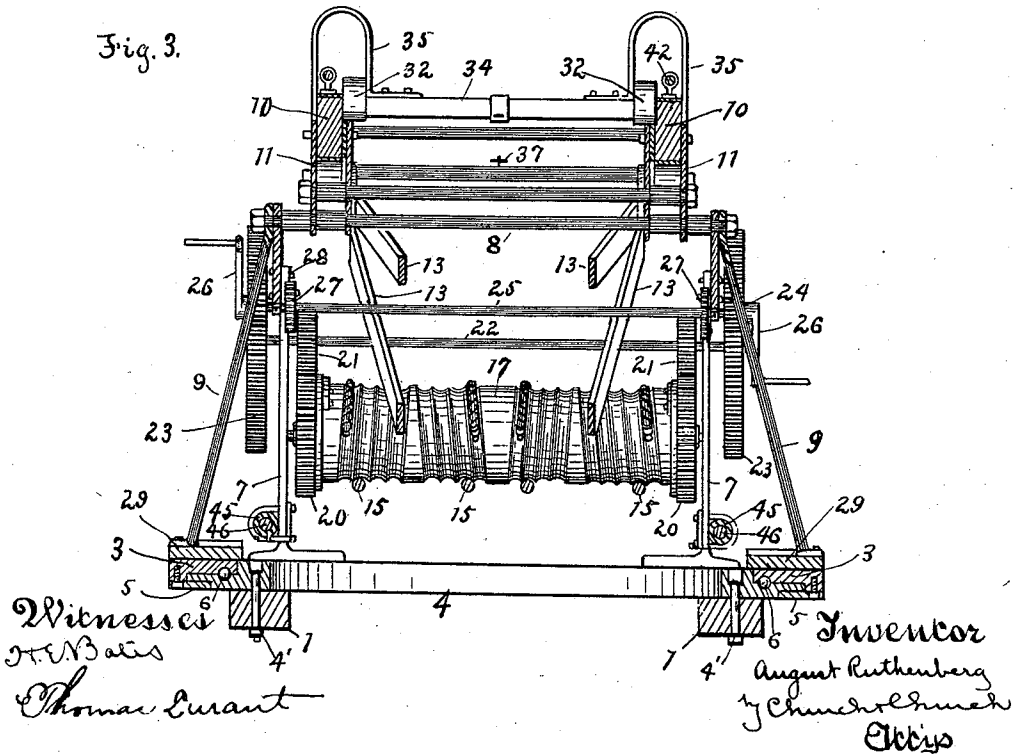
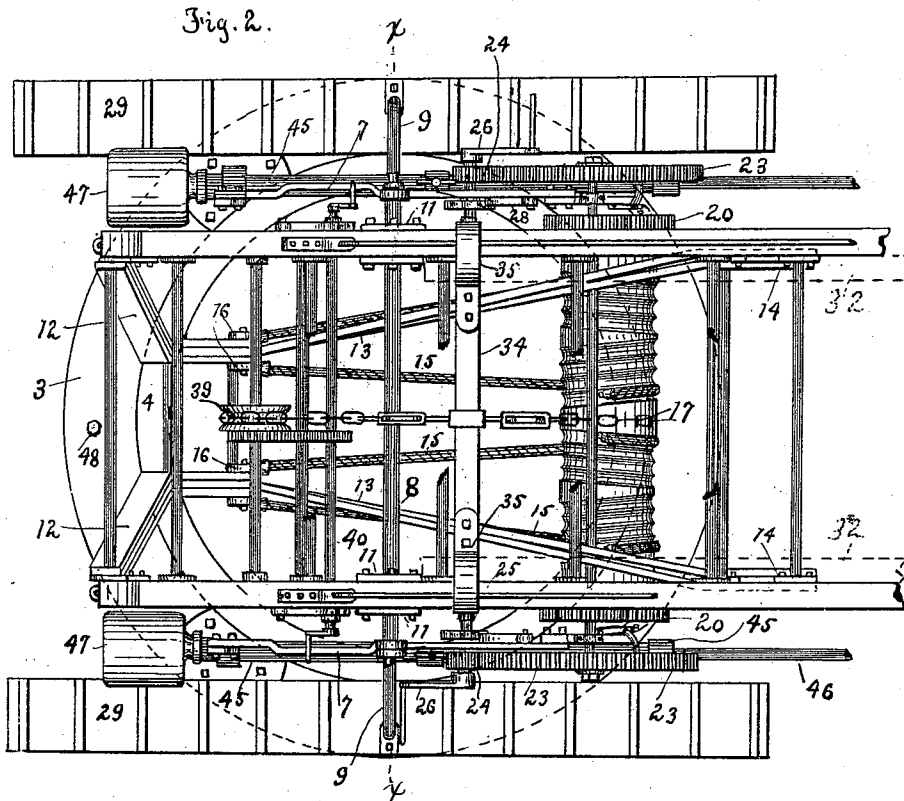

UNITED STATES PATENT OFFICE.

AUGUST RUTHENBERG, OF ROCHESTER, NEW YORK, ASSIGNOR OF ONE-HALF TO JOHN S. GUNSAUL, OF SAME PLACE.

EXTENSION-LADDER TRUCK.

SPECIFICATION forming part of Letters Patent No. 524,047, dated August 7, 1894.

Application filed March 2, 1894. Serial No. 502,137. (No model.)

To all whom it may concern:

Be it known that I, AUGUST RUTHENBERG, of Rochester, in the county of Monroe and State of New York, have invented certain new and useful Improvements in Extension-Ladder Trucks; and I do hereby declare the following to be a full, clear, and exact description of the same, reference being had to the accompanying drawings, forming a part of this specification, and to the reference-numerals marked thereon.

My present invention has for its object to improve that class of ladders such for instance as shown in my prior patent, No. 456,224, granted July 21, 1891, designed more particularly for the use of the fire departments, but of course applicable to other uses, and the invention consists in certain improvements in construction and combinations of parts, all as will be hereinafter fully described and the novel features pointed out in the claims at the end of this specification.

In the accompanying drawings, Figure 1 is a longitudinal section of a ladder constructed in accordance with my invention; Fig. 2, a plan view of the rear portion thereof; Fig. 3, a sectional view on the line $x-x$ of Fig. 2.

Similar reference numerals in the several figures indicate similar parts.

Although the invention is particularly adapted to that class of ladders carried by a wheeled truck or vehicle, in the accompanying drawings I have not deemed it necessary to show the whole of said truck, but have indicated a portion of the frame thereof by 1 and the fifth wheel by 2, as shown in Fig. 1.

The entire ladder and its operating parts are supported upon a turn-table or support 3 resting upon a suitable ring or circular plate 4 secured to the frame 1 by bolts 4', as shown in dotted lines; said turn-table 3 being prevented from vertical movement on the ring 4 by means of the plate 5 projecting beneath a circular flange, as shown in Figs. 1 and 3, and a number of anti-friction balls 6 are arranged between the turn-table and its support to provide for turning the frame easily, as will be understood. Mounted upon the turn-table 3 is a suitable frame composed of the side pieces 7 bolted to the turn-table and connected

by suitable cross bars or rods, one of which latter, 8, constituting the bearing or support for the ladder. Suitable braces 9 are also provided serving to strengthen the frame.

The main or lower ladder 10 is provided with depending brackets 11 pivoted upon the rod or shaft 8, which serves as a pivot on which said ladder is turned, and which is arranged preferably over the center of the turn-table in order to properly distribute the weight of the device, and secured to the lower side of the ladder 10 is a substantially triangular frame composed of the downward extension composed preferably of the double bars or plates 12 arranged at the rear and connected to the extreme end of the ladder and the inclined bracing plates or bars 13 extending upward from said bars 12 and connected to suitable brackets 14 secured to the lower side of the ladder forward of the pivotal point, forming a truss for the ladder. The means for tilting the ladder 10 on its pivots and elevating the forwardly extending portion is also located upon the turn-table 3 and consists in the preferred form, of cables or ropes 15 connected by means of suitable clevises 16 at one end to the lower end of the bars or plates 12, while the other ends of said cables are connected to a drum 17 mounted in suitable bearings in the side pieces 7 of the frame. I prefer to employ four cables for this purpose and to groove the drum so that when the latter is rotated in the direction of the arrow Fig. 1, the two inner cables will be wound from the center outwardly and the two outer cables from the outside of the drum inwardly, as I find that in this way the strain on the drum is more evenly distributed. On the ends of the drum are provided gears 20, meshing with gears 21, on a shaft 22, which latter is provided with the large gears 23 engaged by pinions 24 on a shaft 25 provided with operating handles 26 which latter are preferably removable, said shaft 25 being also provided with ratchet wheels 27 with which co-operate retaining pawls 28.

It will be understood that when desired to raise the ladder, the operators standing on the footboards 29 secured to the turn-table 3, may rotate the handles 26, wind up the cables

and draw the lower end of the ladder down through the means just described, and the end of extension 12 on the opposite side of the pivot, elevating the forward end of the ladder.

The ladder 10 is provided with the usual rungs 30 and at suitable intervals with anti-friction rollers or pulleys 31 upon which the upper extensible section 32 of the ladder rests. This ladder section 32 is also provided with the usual rungs secured by brackets 33, as shown or otherwise and near its lower end, is provided with a cross piece 34 to which or to the ladder itself are connected brackets 35 extending over the sides of the ladder 10 and downward beneath it where they are provided with friction rollers 36 operating on the under side of said ladder, as shown particularly in Fig. 1. Also connected to opposite sides of the cross piece 34 are the ends of a chain 37 passing around chain wheels 38 and 39 rotated from shaft 40 through a gear train 41, so that by the operation of said shaft 40, (which is provided with the movable cranks or handles,) in the direction of the arrow in Fig. 1, the ladder 32 will be extended, suitable ratchet devices being provided for preventing the retrograde movement of the ladder, and retaining it in extended position, as shown particularly in Fig. 2. Suitable truss rods 42 are provided on the upper side of the main ladder 10 for bracing it.

Secured to the lower portions of the sides 7 of the main supporting frame are tubular sockets 45 in which are arranged movable rods or bars 46 having counterweights 47 at their outer ends adapted to be extended to counterbalance the weight of the ladder, as will be understood, and as shown more particularly in my former patent before referred to.

It will be understood from the above that by the use of the cables, the ladder can be quickly raised and the movable ladder ex-

tended by means of the elevating chain and the operating means described. For the purpose of securing the turn-table after it has been moved to the position desired I provide suitable set screws 48 passing through the turn-table and engaging circular base, 4, as shown in Fig. 1.

By the employment of the cables for elevating the ladder instead of the screws and nuts heretofore employed, I am enabled to raise the ladder much more rapidly.

I claim as my invention—

1. The combination with the support, the turntable mounted thereon, the frame on the turntable, the winding drum, the shaft 25 having the handles, gearing connecting said shaft and drum, all mounted on the frame, and the foot-boards on opposite sides of the turntable, of the ladder having the braces 12 and 13, and the cables connecting said braces with the drum, substantially as described.

2. The combination with the support, the turntable, the frame on the latter, the winding drum having the gears, the shaft 22, gears 21 and 23, shaft 25 having gears 24 and ratchets 26, of the ladder pivoted on the frame having braces 12 and 13, and the cables connecting the drum and said braces, substantially as described.

3. The combination with the turn-table and its support, the ladder pivoted on the turn-table, and means for turning it on its pivots, of the ladder sliding on the first-mentioned one having the brackets thereon extending over the pivoted ladder, and the rollers on said brackets, the chain-wheel on the pivoted ladder, and gearing for operating it, and the chain connected to the sliding ladder passing over said chain-wheel, substantially as described.

AUGUST RUTHENBERG.

Witnesses:

FRED. F. CHURCH,
J. S. GRUSAUL.