

July 17, 1934.

P. E. HUNTER ET AL

1,966,504

APPARATUS FOR SORTING SHEETS

Original Filed Nov. 22, 1929

2 Sheets-Sheet 1

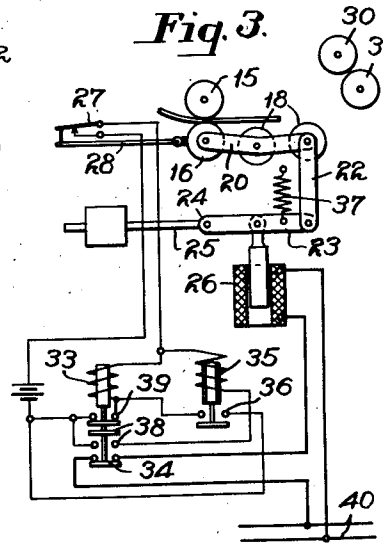
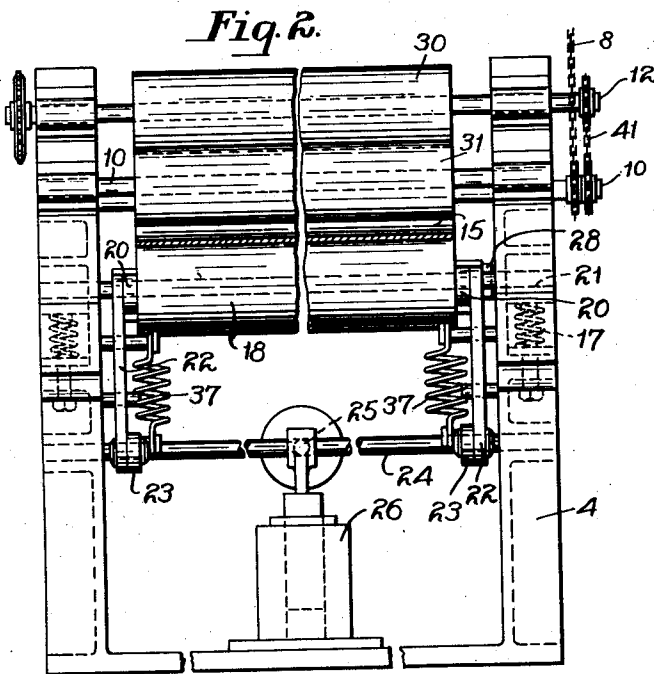
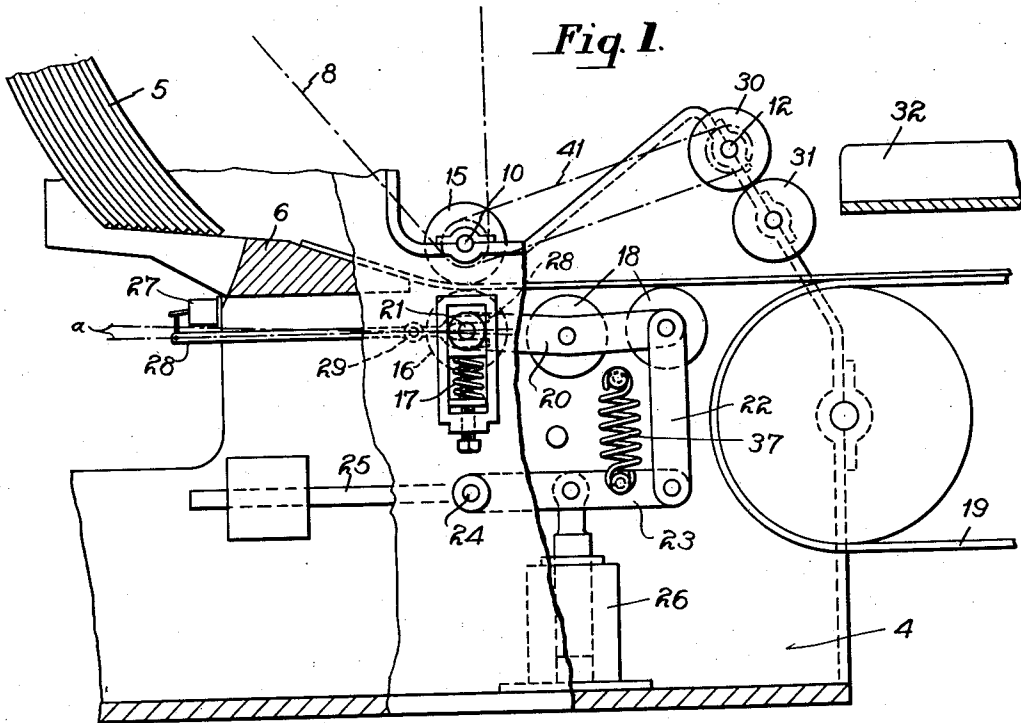

INVENTORS
Percy C. Hunter
& Louis C. Endsley,
By *Archworth Martin,*
Attorney.

July 17, 1934.

P. E. HUNTER ET AL

1,966,504

APPARATUS FOR SORTING SHEETS

Original Filed Nov. 22, 1929

2 Sheets-Sheet 2

Fig. 4.

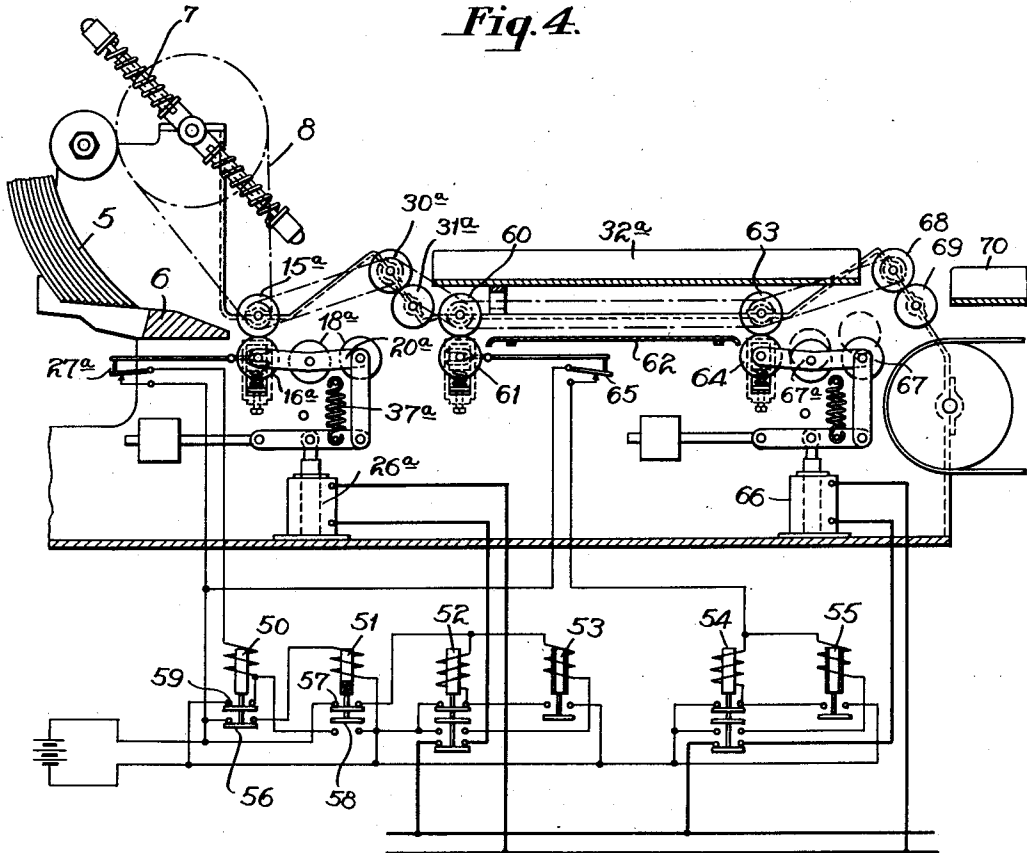

INVENTORS
Percy E. Hunter
& Louis C. Endsley,
By Archworth Martin,
Attorney.

UNITED STATES PATENT OFFICE

1,966,504

APPARATUS FOR SORTING SHEETS

Percy E. Hunter and Louis E. Endsley, Pittsburgh, Pa.; said Endsley assignor to said Hunter

Original application November 22, 1929, Serial No. 409,051. Divided and this application January 4, 1932, Serial No. 584,652

11 Claims. (Cl. 209—88)

Our invention relates to the sorting of sheets and constitutes a division of our copending application No. 409,051, filed November 22, 1929 (now Patent No. 1,850,108). The invention is capable of use in sorting sheets of various kinds of material, but for convenience of description is hereinafter described as employed in connection with the sorting of steel sheets such as are produced in tin plate mills.

At one stage in tin mill operations, sheets are fed from stacks one by one to flattening rolls or to some other destination, and it is of course necessary that defective sheets be sorted or thrown out. The defects may consist in two sheets stuck together; front or rear edges of certain sheets being folded over; excessively thick sheets, etc.

One object of our invention is to provide an improved method and apparatus for automatically discarding or separating defective sheets from those of uniform smoothness and of proper thickness.

Another object of our invention is to provide apparatus that will effectively sort out sheets of excessive thickness no matter whether the excess thickness is uniform throughout the length of the sheet, or is present at only a particular spot in the sheet or at its front or rear edges.

Some of the forms which our invention may take are shown in the accompanying drawings, wherein Figure 1 is a sectional elevational view of sorting mechanism; Fig. 2 is an end view thereof; Fig. 3 is a diagrammatic view showing the manner in which the sheet-guiding mechanism of Fig. 1 is controlled, and Fig. 4 is a modification of the apparatus of Figs. 1 to 3.

The sheets from a pack 5 may be fed, one by one, across a table 6, either manually or by mechanism such as that described in our application above-referred to, such mechanism being indicated somewhat schematically in Fig. 4 of the accompanying drawings, and involving feeding fingers 7 and a drive chain 8 for said fingers.

The chain 8 is driven from a shaft 10 that is in turn driven from a shaft 12. The shaft 12 is provided with a sprocket wheel that may be driven in any suitable manner.

The sheets when advanced across the table 6 are caught between rolls 15 and 16. The roll 15 is carried by the shaft 10 and has frictional contact with the roll 16 either directly or through the medium of a sheet being advanced by the roll. The roll 16 is mounted on a shaft 21 which is spring pressed upwardly by springs 17 to allow yieldable vertical movements thereof.

As heretofore stated, the sheets are fed to the rolls 15—16, one by one. At times, two sheets may be stuck together and therefore be simultaneously moved between the rollers 15 and 16, or a sheet may be excessively thick or have its forward edge bent back. In such case, it is desired to deflect the imperfect sheets from the normal path of travel of the separated sheets. In order to automatically effect this separation or deflection, we mount guide rollers 18 beyond the rollers 15 and 16. These rollers ordinarily direct the sheets to a conveyer 19 which leads to sheet-flattening rolls (not shown) or to any other desired destination, the rollers 18 being journaled on a rocking frame 20 which is pivoted at one end to the shaft 21 that carries the roller 16. The outer end of the frame 20 carries a pair of links 22 that depend therefrom and at their lower ends are pivotally connected to levers 23.

The rear ends of the levers 23 are connected to a rock shaft 24 that is journaled in the sides of the base 4. A weighted arm 25 is secured to the shaft 24. It will be seen that as the shaft 24 is oscillated, the links 22 will be moved up and down to raise and lower the guide rollers 18. The rollers 18 are normally maintained in the position shown in Fig. 1, by means of a solenoid 26 whose circuit is controlled by a switch 27. An operating lever 28 for the switch 27 is pivotally mounted at 29 and has its one end bifurcated, with the arms of the bifurcations engaged by the shaft 21, so that as such shaft is moved up and down, the switch lever 28 will be rocked to open and close the switch 27. The throw of the switch lever 28 as shown more clearly by the broken lines *a—*a**, Fig. 1, is such that if two sheets which are stuck together pass between the rolls 15 and 16, the lever will be moved such distance that the switch 27 is opened, thus breaking the control circuit for the solenoid 26 and permitting springs 37 to swing the frame 20 and the rollers 18 carried thereby upwardly such distance that the two sheets will be directed between rollers 30 and 31 to a receiving table or rack 32.

This breaking of the circuit opens the circuit of an auxiliary relay 33, which through switch contacts 34, controls the circuit of the solenoid 26 that has connection to a suitable power supply line 40, such circuit being broken by the switches 34 so long as the coil of the relay 33 is de-energized. The solenoid 26 will remain de-energized for a slight period of time after the forward edges of the sheets to be discarded actually pass between the rolls 15—16, to give such sheets time to reach the rolls 30 and 31. As soon

as the sheets have passed completely from between the rolls 15 and 16, the switch 27 is permitted to again close, thus completing the energizing circuit of a slow-to-energize relay 35, this circuit extending through the now closed contacts 38 of the relay 33.

After a short interval of time this relay 35, through its associated switch 36 completes a circuit through the coil of the relay 33 which results in closing of the switch contacts 34 to cause the energization of the solenoid 26 from the power line 40, thus causing the solenoid 26 to return the frame 20 to its lower position, as shown in Fig. 1, against the tension of the springs 37. The energization of the relay 33 also completes a holding circuit for itself at the contacts 39, and opens the circuit of the relay 35 at the contacts 38 and this relay restores to normal. The springs 37 are depended upon to swing the frame 20 and the rolls 18 to upper position when the coil 26 is de-energized and the weighted lever 25 serves as a counter-balance for such frame and rolls.

It will therefore be seen that at a predetermined time after a thickened sheet or two adhering sheets have passed from between the rolls 15 and 16 and are passing through the rolls 30 to 31 to the table 32, the guide rolls 18 will be returned to their lower position to direct succeeding sheets to the conveyer 19. This arrangement permits intimate spacing of successive sheets which therefore lessens the time required to sort a given number of sheets.

When a sheet of abnormal thickness passes between the rolls 15—16 the above-described operation takes place and causes delivery of such sheet to the table 32. Also, if the leading or forward edge of a sheet is bent back or bulged to such an extent that it might cause damage to the sheet-flattening rolls, the solenoid 26 will be de-energized as above-described and such sheet will be directed through the rollers 30—31 to the table 32. The time element of the relay 35 is sufficient to permit the guide rollers 18 to remain in elevated position until the deformed sheet enters the rollers 30—31. In this manner, only the desired sheets are permitted to advance one-by-one to the conveyer 19.

The roll 30 is carried by the shaft 12.

From the foregoing it will be seen that the timing relay 35 is controlled by the switch 27, and that the deflector guide rolls 18, upon movement to deflected position, are normally maintained in elevated position for a predetermined period of time. However, if the switch 27 should be reactivated by the passage of a thickened portion or area of a sheet or of successive sheets between the rolls 15—16, before the timing period has elapsed, the relay 35 will be restored to normal and then re-initiated to effect a full timing period beginning from the subsequent operation of the switch. Thus, the timing period is extended through successive operations of the switch 27 which occur during the timing period, thereby continuously maintaining the guide rolls 18 in elevated position to direct such damaged sheets to the rolls 30—31.

Referring to Fig. 4, we show a modified form of the apparatus of Fig. 1, wherein provision has been made not only for deflecting thick sheets, but for deflecting sheets from the normal path of travel of the separated sheets, in case either the leading edge or the rear edge of a separated sheet is bent back or bulged or which has a thickened area or spot intermediate the edges of the sheet.

In order to automatically effect this deflection of damaged sheets, we provide apparatus that is actuated by the bent portion of the sheet, such apparatus being in duplicate and each being substantially similar to the deflecting apparatus of Fig. 1.

The sheets are fed from a pack, one-by-one, by feeding members 7 and between feeding rolls 15a and 16a. In case a sheet is of abnormal thickness, or the leading edge of the sheet is bent back, a switch 27a is actuated to break the control circuit for a hold-down solenoid 26a, and permitting springs 37a to swing a rack 20a and guide rollers 18a carried thereby upwardly so that such sheets will be directed between rollers 30a and 31a to a receiving table 32a.

The actuation of the switch 27a does not result in the immediate de-energization of the hold-down solenoid 26a and the swinging up of the deflecting rollers 18a, but the solenoid is maintained energized for a short time interval thereafter, for a purpose hereinafter described.

The actuation of the switch 27a results in the de-energization of a relay or switch 50, and at contacts 56 of this relay the circuit of a slow-to-de-energize relay 51 is opened. After a short interval of time, relay 51 de-energizes and at contacts 57 opens the circuit of a relay 52 which de-energizes.

At contacts 58 of the relay 51 an energizing circuit is completed for the relay 50 which extends through the switch 27a and this relay energizes, when the switch 27a is actuated, to complete a locking circuit for itself at contacts 59 and to complete the energizing circuit for the relay 51. Relay 51 energizes and at contacts 58 opens the original energizing circuit for the relay 50, and at contacts 57 completes a point in the battery circuit for the relays 52 and 53. The operation of the relay 52 which is now de-energized, and the slow-to-energize relay 53 is the same as the operation of the relays 33 and 35, as heretofore described.

Thus, sheets of abnormal thickness or sheets having their forward edge bent back or bulged will be deflected from the normal path of travel and prevented from advancing to the conveyer.

However, if the rear edge of a sheet is bent back, or is of abnormal thickness adjacent to its rear edge, such sheet passes between the rolls 15a and 16a and is guided by the rollers 18a between rolls 60 and 61. These rolls advance said sheet forwardly along a guide plate 62 and between rolls 63 and 64. The rear edge of the sheet being bent back, causes the operation of the switch 27a which is associated with the roll 16a, but due to the retarded action of the control circuit, the solenoid 26a remains energized for a short time interval, permitting the sheet to completely pass from between the rolls 15a and 16a before the rollers 18a swing up in their deflecting movement.

The rollers 18a do not exert a damaging force on a sheet, which would be the case if the rollers were permitted to swing upwardly immediately after the operation of the switch 27a, since the sheet by reason of its disengagement with the rolls 15a and 16a is merely flexed upwardly by the rollers 18a.

A switch 65 is associated with the roll 61 and is actuated by the bent portion of the sheet in its passage between the rolls 60 and 61. The actuation of the switch 65 results in the de-energization of a hold-down solenoid 66 through the operation of relays 54 and 55, that operate in the

same manner as the relays 33 and 35. The solenoid 66 releases the rollers 67 carried by a rocking frame 67a which move upwardly to deflect the sheet between rollers 68 and 69 to a receiving table 70. The rolls 60 and 61 are spaced such distance from the rollers 68 and 69 that the leading edge of the sheet will be directed between the rollers.

The rolls 16a, 61 and 64 are spring-pressed upwardly to allow yieldable vertical movements thereof. The rolls 15a, 60 and 63 and the rollers 30a and 68 are driven at the same speed in any suitable manner.

From the foregoing it will be seen that if the forward edge of a sheet is bent back or only the front portion of the sheet excessively thick, the guiding rolls 18a will not be tripped to their lowermost position until the forward edge of the sheet has entered between the rolls 30a-31a, even though the switch 27a has been restored to its original position through raising of the roll 16a while unthickened portions of the sheet are still passing between the rolls 15a-16a.

Also, this delayed action of the solenoid 26a prevents the operation of the deflecting rolls 18a by a thickened rear portion of a sheet until after the sheet has been released by the rolls 15a-16a, when passing between the rolls 60-61.

Similarly, the delayed action of solenoid 66 prevents retractive movement of the deflecting rolls 67 until after the thickened rear portion of a sheet has passed from between the rolls 60-61, and its front edge caught by the rolls 68-69.

It will be apparent that the time element devices can be set to operate at a definite rate as compared to the speed of travel of the sheets. Thus the time element 35 of Figs. 1 and 3, for example, can be arranged that the deflecting rolls 18 will be held in elevated position until a sheet which contains a thickened portion at any point between its forward edge and somewhat to the rear of its mid portion has been caught by the rolls 30-31.

In case the forward edge of a sheet has reached the roll 31a before the frame 20a is moved upward to direct it between the rolls 30a-31a, the said edge, if it comes against the nearest surface of the roll 31a, will be carried by the roll into the paths between the rolls 30a and 31a, since the roll 31a is driven. On the other hand, if the edge of the sheet engages the roll 31a at such a low point that it will not be dragged upwardly by the roll, it will, of course, slide beneath the roll and enter the rolls 60 and 61.

We claim as our invention:—

1. Sheet-sorting apparatus comprising means for advancing sheets, means actuated by abnormal thickness of the sheet material adjacent to the forward edges of the sheets for diverting them from a given path of travel at one point, and means actuated by abnormal thickness of the sheets adjacent to their rear edges for diverting them from said given path at another point.

2. Sheet-sorting apparatus comprising means for advancing sheets, a feeler member actuated by sheets of abnormal thickness, a sheet deflector controlled by said member, a second means for advancing sheets, a second feeler device actuated by sheets of abnormal thickness, when advanced by the second-named means, a sheet deflector controlled by said device, and a retarding device operable upon movement of the said feeler

member and timed for delaying movement of the first-named deflector member to sheet-deflecting position until after a sheet engaged by the second-named advancing means has been released by the first-named advancing means.

3. Sheet-sorting apparatus comprising means for advancing sheets, a feeler member actuated by sheets of abnormal thickness, a sheet deflector controlled by said member, a second feeler device actuated by sheets of abnormal thickness, means for positively advancing sheets from the first-named feelers to the second-named feeler, a sheet deflector controlled by said second feeler device, and a retarding device for delaying return movement of the second-named deflector, said second-named deflector being effective to deflect sheets that are thickened only at points adjacent to the rear edge thereof.

4. Sheet-sorting apparatus comprising deflector means mounted at each of two points spaced longitudinally of a path of travel for sheets, control members therefor actuated by sheets of abnormal thickness, means for positively advancing sheets past said two points, and means for retarding operation of the first deflector means into sheet-deflecting position, a sufficient period of time to render the same ineffective to deflect a sheet that is thickened only at a point adjacent to its rear edge.

5. Sheet-sorting apparatus comprising means for advancing sheets, a deflector for directing sheets from a given path of travel, a feeler device actuated by sheets of abnormal thickness, for operating the deflector, and a timing device initially actuated and subsequently controlled by said feeler device for maintaining the deflector in deflected position for a predetermined period of time, said timing device being initiated only after a thickened portion has passed the feeler device.

6. Sheet-sorting apparatus comprising means for advancing sheets, a deflector for directing sheets from a given path of travel, a feeler device actuated by sheets of abnormal thickness, for operating the deflector, a second advancing means for moving said deflected sheets, and timing means controlled by said feeler device and operable to maintain said deflector in deflected position until the leading edge of the deflected sheet reaches said second-named advancing means.

7. Sheet-sorting apparatus comprising means for advancing sheets, a deflector for directing sheets from a given path of travel, a feeler device actuated by abnormal thickness of the sheet material, for operating said deflector, and means controlled by said feeler device for maintaining said deflector in deflected position for a predetermined period of time after a thickened portion of a sheet has passed the feeler device, said last-named means being responsive to subsequent operations of said feeler device while said deflector is maintained in deflected position, for further delaying return of said deflector to normal position.

8. Sheet-sorting apparatus comprising a deflector pivotally supported at one end, means for moving the free end of said deflector into position to register with one of a plurality of discharge stations, delay means operative to maintain said deflector in one of its positions a predetermined period of time before permitting movement of the deflector to its other position, and feeler means responsive to the thickness characteristic of sheets advanced across said deflector to one of said discharge stations, for con-

trolling the operation of said deflector and said delay means.

9. Sheet-sorting apparatus comprising a deflector actuated by sheets of abnormal thickness for directing said sheets from a given path of travel, timing means operative for maintaining said deflector in deflected position for a predetermined period of time, and means actuated by successive imperfections of each abnormal sheet, for controlling said timing means.

10. Sheet-sorting apparatus comprising a feeler device actuated by thickness imperfections of sheets, a deflector responsive to initial actuation of said feeler, to direct sheets of abnormal thickness from a given path of travel, and a timing device initiated upon each actuation of said feeler, to maintain said deflector in deflecting po-

sition a predetermined period of time measured from the last actuation of the said feeler device.

11. Sheet-sorting apparatus comprising means for advancing sheets successively for continuous movement, a deflector actuated by sheets of abnormal thickness for directing said sheets from a given path of travel, timing means operative to maintain said deflector in deflected position for a predetermined period of time, and means responsive to the thickness characteristics of sheets moving toward said deflector, for initially actuating and subsequently controlling the operation of said timing means independently of traveling movement of the sheet past said deflector.

PERCY E. HUNTER.
LOUIS E. ENDSLEY.

20	95
25	100
30	105
35	110
40	115
45	120
50	125
55	130
60	135
65	140
70	145
75	