

(No. Model.)

G. V. NAUERTH.

FILE FOR POSTAL AND OTHER CARDS.

No. 254,836.

Patented Mar. 14, 1882.

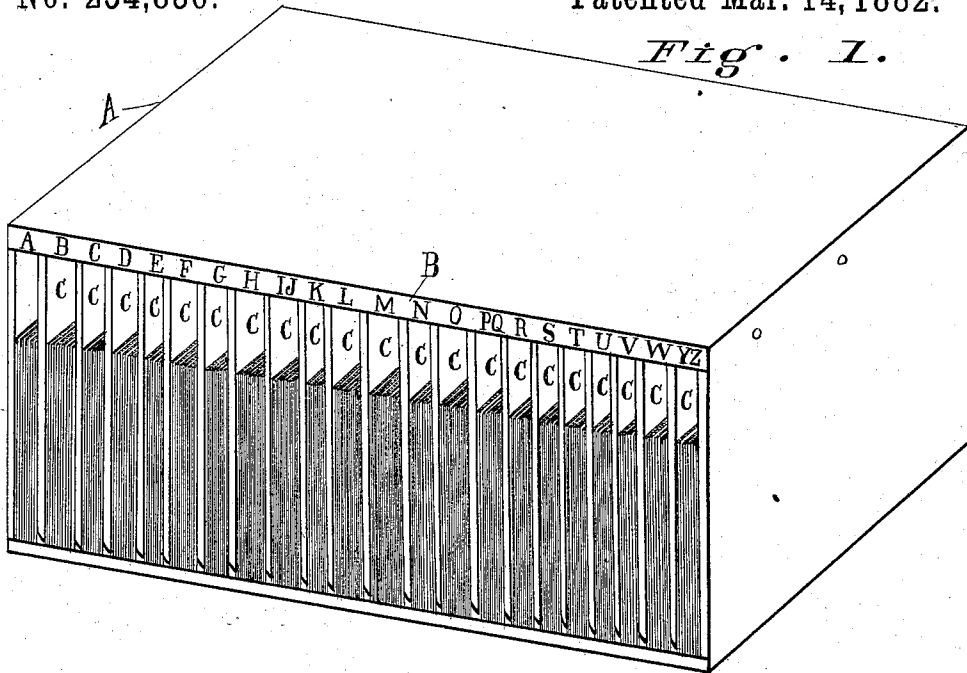

Fig. 1.

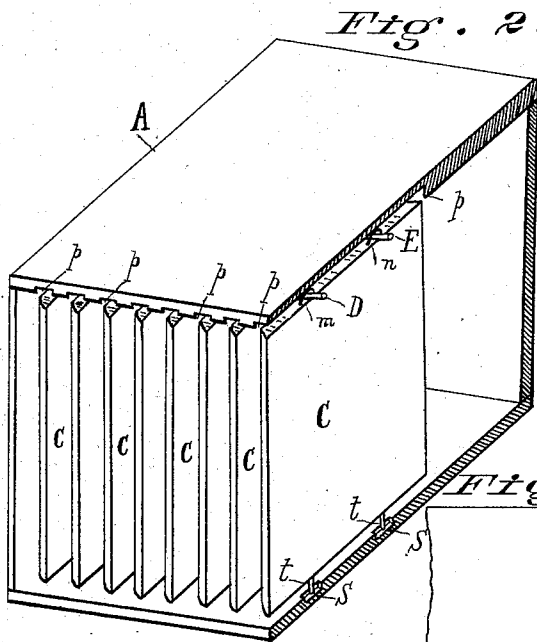

Fig. 2.

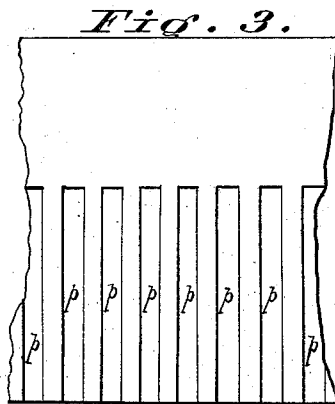

Fig. 3.

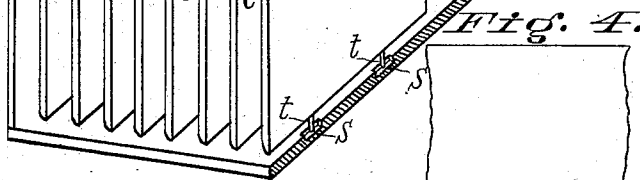

Fig. 4.

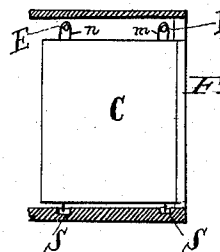

Fig. 5.

Attest.

J. N. Strehli
L. W. John

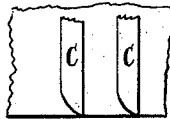
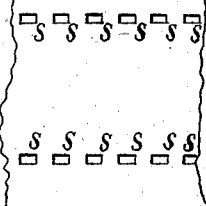

Fig. 6.



George V. Nauert
per Wm. Hubbell Fisher,
Atty.

UNITED STATES PATENT OFFICE.

GEORGE V. NAUERTH, OF DAYTON, OHIO.

FILE FOR POSTAL AND OTHER CARDS.

SPECIFICATION forming part of Letters Patent No. 254,836, dated March 14, 1882.

Application filed July 26, 1881. (No model.)

To all whom it may concern:

Be it known that I, GEORGE V. NAUERTH, a resident of the city of Dayton, in the county of Montgomery and State of Ohio, have invented certain new and useful Improvements in Files for Postal and other Cards, of which the following is a specification.

The object of my invention is to provide a file for postal and business cards, tags, or the like, whereby and wherein such cards, &c., can be filed and classified in the most rapid and convenient manner.

The various features of my invention will become apparent from the following description.

Referring to the drawings, Figure 1 is a front view, in perspective, of a card-file illustrating my invention and containing cards placed in said file. Fig. 2 is a front view, in perspective, of said file empty and with the index removed, so as to show the preferred mode of attaching the movable partitions between the cards at the top and bottom of the box or case of the file. Fig. 3 shows a portion of the under side of the top of the box or case of the file. Fig. 4 shows a portion of the top side of the bottom of the box or case of the file. Fig. 5 is a diminished view of a vertical transverse section of the file, taken between two vertical partitions, the front of the file being at the right hand and the back and rear portions of the top and bottom of the box or case being removed. Fig. 6 shows the front portion of the top of two adjacent partitions, shown nearly full size, and illustrating how the front edge of each partition is preferably beveled.

The box or case A of the file is constructed of wood or other suitable material, and preferably open only in front. The inside depth of the box A from front to rear is preferably the exact length of the cards to be filed therein. The inside height of the box is preferably somewhat greater than the width of the cards to be filed, thus allowing sufficient space above the cards when filed for the insertion of the finger into said space and the easy withdrawal of the cards by means of the hold acquired thereon by said finger. Each compartment is sufficiently wide to admit of the insertion of the finger to withdraw the cards and sufficiently narrow to compel the cards to remain in an upright position.

An index, B, or indices for indicating what class or description of cards each compartment is to contain, is suitably secured to an appropriate portion or portions of the file. In the present illustration the cards are classified by the first letter of the surname of the party from whom they are received or whose name they bear. Each index-letter is preferably placed over the vertical center of the compartment which it is to designate, and in which cards to be filed under said letter are placed, and is attached by any suitable means to the upper fixed portion of the front of the case A.

The various partitions C C C, separating the compartments and forming the side walls of the latter, are so combined with the case A as to be laterally movable, and the means whereby they are rendered thus movable are to be varied as desired. One very useful and convenient form is shown in the drawings, and consists as follows: Each partition is provided at top with two openings or eyes or hooks or extensions, *m* and *n*. Through one of these—viz, *m*—passes a rod, D, located at or near the top of said case and parallel to the length thereof, and fixed thereto at or near the ends W of the said case, and through each of the eyes or hooks indicated by *n* passes a rod, E, running parallel to the length of said case, and located preferably at the rear of said case, and near or at the top thereof, and fixed to the case at or near the ends W of the latter. The partitions are thus suspended upon said rods, and are capable of being slid or moved laterally thereon. Provision is made to confine the capacity of lateral adjustment of the said partitions within certain desired limits, so that as adjacent partitions forming one compartment are moved apart they cannot be separated so far as to unduly encroach upon adjacent compartments, and when moved toward each other they cannot be brought so closely together as to extinguish the compartment which they include. In the present instance the provision for limiting the lateral movement of said partitions consists as follows, viz: The under side of the top of the case A is provided with the recesses *p p*, (see Fig. 3,) and the upper side of the bottom of the said case is provided with the recesses *s s*. (See Fig. 4.) Each recess in the top of the case receives the head of the hook or eyes of one partition, and each recess in the

bottom of the case receives a pin, *t*, or suitable extension, projecting vertically downward from the bottom of the partition. The bottom of the pin does not touch the bottom of the recess in which it plays, and thus all friction resulting from the impingement of the pin against the bottom of said recess is avoided, and the suspended partitions are free to retain their vertical position.

The partitions *C* are preferably constructed of wood, and are thin, and the side of their front edges (preferably the left side) is beveled, as shown, in order that when the card is inserted in its proper compartment it may be placed in the order of its date, as well as according to class, by inserting it on the right-hand side of its compartment. The beveled edge of the partition between the compartment in which the card is to be filed and the next compartment on the right being on the left of said partition, the card will readily slide into the desired compartment, and thus the cards in each compartment will be filed in the order of their respective dates.

When, on account of certain cards of certain classes being much more numerous than those in other classes, it becomes necessary in the construction of the file to make additional space for the accommodation of such class, the compartment designed to receive such class is to be made wider than the other compartments, and in the present instance this can be accomplished by placing the recesses *p*, which respectively receive the eye or hook, farther apart and the recesses which receive the pin *s* farther apart.

Among the various advantages derived from my improved mode of indexing is the following: Each partition between index-letters or index-marks is movable only along the space between the letters, so that no confusion can arise, and so that the proper letter or mark is always precisely above its corresponding compartment. And among the various obvious advantages arising from the employment of my file is the following one: It is not necessary to employ both hands in filing the cards, as in other systems. By my plan, while a batch of cards are held in the left hand, they are rapidly and accurately thrown into their proper places with the right hand. There are no index-leaves to raise and

hold in place, and cards cannot be disarranged or displaced, as occurs where cards are filed under other systems.

What I claim as new and of my invention, 55 and desire to secure by Letters Patent, is—

1. In a file for cards, the combination of a case or frame-work, and laterally-movable partitions suspended within said box, and a provision, substantially as described, whereby said partitions are prevented from coming into contact, substantially as and for the purposes specified. 60

2. In a file for cards, the case or frame-work *A* and the suspended laterally-movable vertical partitions, said case being provided with recesses in the top and bottom of the box, receiving the ends or extensions of the vertical partitions and controlling the extent of the lateral adjustment of said partitions, substantially as and for the purposes specified. 70

3. The combination of the case *A*, provided with the rods *D E*, and the separate laterally-movable partitions, suspended on said rods by means of hooks or eyes, substantially as and for the purposes specified. 75

4. The combination of the case *A*, provided with the rods *D E*, and the recesses *p*, and the separate laterally-movable partitions, suspended on said rods by means of hooks or eyes entering the said recesses, substantially as and for the purposes specified. 80

5. The combination of the case *A*, provided with rods *D E*, and the recesses *p s*, and the vertical partitions provided with beveled edges and suspended from and sliding laterally on said rods, substantially as and for the purposes specified. 85

6. In a postal-card file, the vertical laterally-movable partitions *C*, suspended from the under side of the top of the case, and not resting on the bottom of said case, the upper and lower edges of said partitions being provided with means, substantially as described, for controlling the amount of the lateral movement of said partitions and for permitting an equal degree of movement at top and bottom, substantially as and for the purposes specified. 90

GEO. V. NAUERTH.

Attest:

W. BELVILLE,
EMMA E. NAUERTH.