



(72) MULLER, ROLF, JP

(72) BLOCH, HANSPETER, CH

(71) INVENTIO AG, CH

(51) Int.Cl.<sup>7</sup> B66B 7/00, B66B 11/02

(30) 1999/05/07 (99 810400.4) EP

(54) **EQUIPEMENT DE TRAVAIL DANS UN Puits D'ASCENSEUR**

(54) **EQUIPMENT FOR CARRYING OUT OPERATIONS IN A LIFT  
SHAFT**

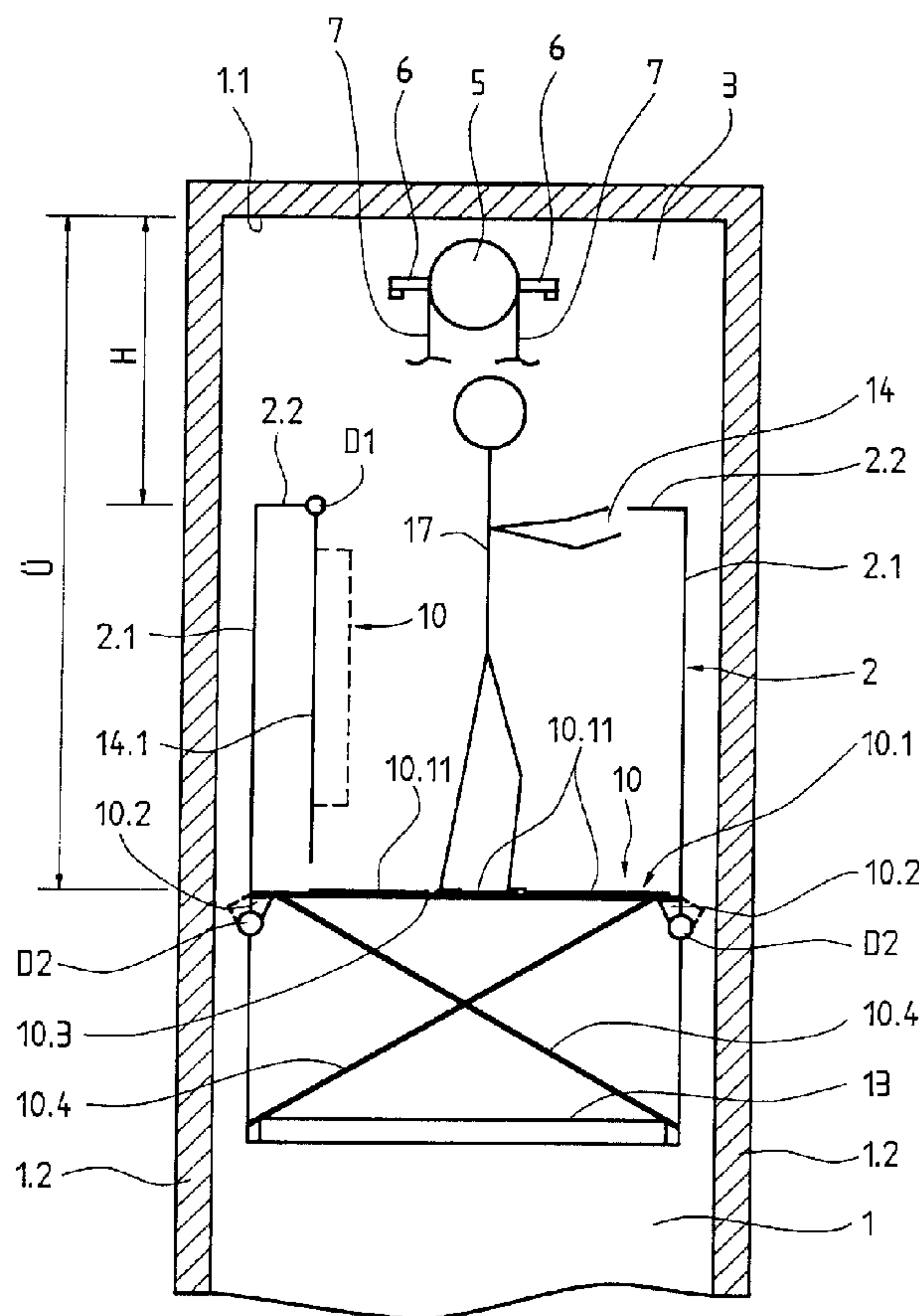

(57) This maintenance trestle (10) is, as shown by a dashed line, stowable in folded-together form at the hatch cover (14.1). For erection of the maintenance trestle (10), the hatch cover (14.1) is tilted into the lift cage (2) about a first fulcrum (D1). The maintenance trestle (10) is now accessible in folded-together form for the erecting. Firstly, several supports (10.1) arranged in cage walls (2.1) are pivotable into the lift cage (2) and transverse connectors (10.3) are arranged at the supports (10.2). The transverse connectors (10.3) carry plates (10.11) forming the platform (10.1). For stabilising the maintenance trestle (10), diagonally extending stays are arranged between the supports (10.2) and a cage floor (13). With the maintenance trestle (10) in work setting, the safety of the engineer (17) is taken care of and the prescribed over-travel ( $\ddot{U}$ ) achieved, because the distance between the cage ceiling (1.1) and the platform (10.1) is determinative for that.



Summary:

This maintenance trestle (10) is, as shown by a dashed line, stowable in folded-together form at the hatch cover (14.1). For erection of the maintenance trestle (10), the hatch cover (14.1) is tilted into the lift cage (2) about a first fulcrum (D1). The maintenance trestle (10) is now accessible in folded-together form for the erecting. Firstly, several supports (10.1) arranged in cage walls (2.1) are pivotable into the lift cage (2) and transverse connectors (10.3) are arranged at the supports (10.2). The transverse connectors (10.3) carry plates (10.11) forming the platform (10.1). For stabilising the maintenance trestle (10), diagonally extending stays are arranged between the supports (10.2) and a cage floor (13). With the maintenance trestle (10) in work setting, the safety of the engineer (17) is taken care of and the prescribed over-travel (Ü) achieved, because the distance between the cage ceiling (1.1) and the platform (10.1) is determinative for that.

15

(Fig. 1)

IP 1225

1

Description:

Equipment for carrying out operations in a lift shaft

- 5 The invention relates to equipment for carrying out operations in a lift shaft, in which a lift shaft with a maintenance trestle, from which the operations can be carried, is movable.

10 Equipment for the servicing of shaft equipment of a lift installation has become known from the specification JP 05097357. A platform which is tiltable out of the cage wall and serves as a standing surface for the engineer during servicing operations is provided in a lift cage. Provided in the roof of the lift cage is a hatch which is closable by means of a cover and which affords access to the shaft equipment. The engineer stands up on the platform and can carry out the operations in the shaft with his upper body protruding out of the cage.

15 A disadvantage of the known equipment resides in the fact that the cage wall supporting the platform has to be mechanically reinforced and in addition fittings for the tilting and fixing of the platform are necessary, at which the lift users can be caught by articles of clothing or objects, because the platform is disposed in the standing region of the lift users.

20 Here, the invention will create a remedy. The invention, as it is characterised in claim 1, meets the object of avoiding the disadvantages of the known equipment and of creating equipment for operations in a lift shaft, which equipment does not represent a risk either for the engineer or for the lift users in the lift cage.

25 The advantages achieved by the invention are essentially to be seen in that there is no risk for the lift cage users of injury on parts of the maintenance trestle, because the maintenance trestle is located outside the standing region of the lift cage users. The cage interior is not adversely affected by the maintenance trestle. In terms of selling strategy the aesthetic presentation of the cage interior is of great economic significance. The  
30 maintenance trestle according to the invention completely and entirely meets this requirement, for example by the invisible arrangement of the maintenance trestle. The maintenance trestle according to the invention also has an increased load-bearing capability, so that parts to be mounted or demounted in the shaft can be intermediately placed on the maintenance trestle. The position of the hatch or the ceiling opening in the  
35 roof of the lift cage can be so selected for the performance of operations in the lift shaft

that the hatch is not overlapped by shaft equipment arranged in the shaft head, wherein in this case the maintenance trestle lies in the projection of the hatch and moreover has a sufficiently large standing area. The position of the hatch, the sufficient standing area and the increased load-bearing capability of the maintenance trestle guarantee the safety of the engineer. Moreover, the maintenance trestle is extremely simple in operation and is quickly ready for use without effort.

The invention is explained in more detail in the following by reference to a drawing illustrating an example of embodiment.

10

There:

Fig. 1 shows a schematic illustration of a lift cage, which is stopped at the top stopping point and which has a maintenance trestle, in a lift shaft with shortened shaft head.

15

A lift shaft, in which a lift cage 2 is movable, bounded by shaft walls 1.2 is denoted by 1 in Fig. 1. A drive pulley 5, which is connected with a drive that is not illustrated, is arranged in the shaft head 3. The drive pulley 5 and/or the drive is supported by, for example, a wall bracket 6. A carrying cable 7 has a cable course which is not illustrated, for example from a fixed point over a deflecting roller of the lift cage 2 or, in the case of a looping underneath, over two deflecting rollers, further over the drive pulley 5, further over a deflecting roller of a counterweight which is not illustrated and further to a further fixed point.

25

A maintenance trestle denoted by 10 is arranged in the lift cage 2 and serves for the maintenance of lift equipment, such as, for example, drive pulley 5, drive, support cable 7, guide rails, lift switches, etc. A standing area from which the operations in the lift shaft 1 are carried out is designated in the following by platform 10.1. For the transport of persons and goods, the maintenance trestle 10 is stowable at a hatch cover 14.1 as shown by a dashed line. For maintenance operations in the lift shaft 1, the maintenance trestle 10 can be erected as shown in Fig. 1.

30

The maintenance trestle 10 is, as shown by a dashed line, stowable in folded-together form at the hatch cover 14.1. On erection of the maintenance trestle 10, the hatch cover

35

14.1 is tilted about a first fulcrum D1 into the lift cage 2. The maintenance trestle 10 is now accessible, in folded-together form, for erection. The cage walls 2.1 are supporting parts of the maintenance trestle 10. Initially, several supports 10.2 arranged in the cage walls 2.2 are pivoted into lift cage 2 and, for example, telescopic or foldable transverse connectors 10.3 are arranged at the supports 10.2. The transverse connectors 10.3 carry plates 10.11 forming the platform 10.1. For stabilising the maintenance trestle 10, for example diagonally extending and telescopic or foldable stays 10.4 are arranged between the supports 10.2 and a cage floor 13.

10 The supports 10.2 are pivotable about a second fulcrum D2. For the transport of persons and goods, the supports 10.2 are in the setting, which is shown in dashed lines, outside the lift cage 2.

15 In the case of lift cages 2 with handrails, the handrails can be used as supports for the transverse connectors 10.3. The supports 10.2 shown in Fig. 1 are not necessary in this variant of embodiment; the remaining parts of the maintenance trestle 10 remain the same as explained above.

20 A hatch 14, which is closable by means of the hatch cover 14.1, is provided in the roof of the lift cage 2. As Fig. 1 shows, the hatch cover 14.1 is tiltable about the first fulcrum D1, but it can also be constructed as a removable hatch cover 14.1.

25 The position and the size of the hatch 14 are so selected that the hatch 14 is not overlapped by shaft equipment, such as, for example, the drive pulley 5 and/or by the drive, arranged in the shaft head 3. The shown lift disposition, without a machine room, offers, by its shortened shaft head 3, for the maintenance of the cage roof an insufficient height H for a prescribed over-travel (distance between cage ceiling 2.2 and shaft ceiling 1.1) of, for example, one metre. With the maintenance trestle 10 according to the invention in the shown working setting, the safety of the engineer 17 is taken care of and  
30 the required over-travel  $\ddot{U}$  achieved, because the distance between the cage ceiling 2.2 and the shaft ceiling 1.1 is no longer determinative, but rather the distance between the platform 10.1 and the shaft ceiling 1.1, and because no shaft equipment in the shaft head 3 overlaps the hatch 14.

## Patent Claims:

1. Equipment for carrying out operations in a lift shaft, in which a lift cage with a maintenance trestle, from which the operations can be carried out, is movable,  
5 characterised in that the cage walls are supporting parts of the maintenance trestle, which is foldable together, with a platform, from which the operations in the lift shaft can be carried out.
2. Equipment according to claim 1, characterised in that the lift cage has supports  
10 which are arranged at the cage walls and carry the maintenance trestle with platform .
3. Equipment according to claim 1 or 2, characterised in that the supports are pivotable into the lift cage for the erection of the maintenance trestle.
- 15 4. Equipment according to claim 1 or 2, characterised in that handrails arranged at the cage walls serve as supports.
5. Equipment according to claims 1 to 4, characterised in that the maintenance trestle is stowable at a hatch cover.  
20
6. Equipment according to one of the preceding claims, characterised in that the maintenance trestle comprises transverse connectors which are connectible with the supports and support the platform.
- 25 7. Equipment according to claim 6, characterised in that for stabilising the maintenance trestle diagonally extending stays are arranged between the supports and a cage floor.

Fig. 1

