

(No Model.)

3 Sheets—Sheet 1.

M. MAYER.  
SEESAW.

No. 525,107.

Patented Aug. 28, 1894.

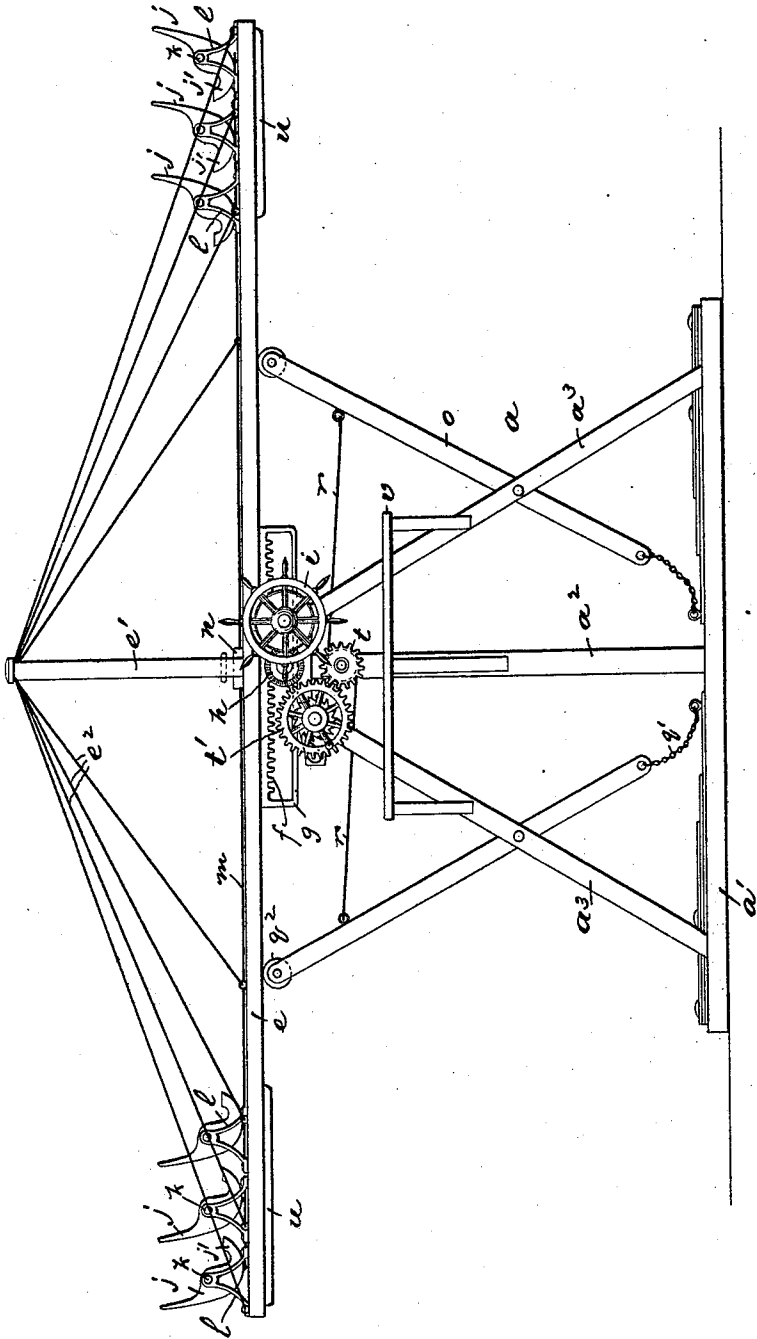

Fig. 1.

Witnesses

Inventor,

Robert Loellinger  
James Meyler

Maximilian Mayer,

By Dracut Co. Attys.

(No Model.)

3 Sheets—Sheet 2.

M. MAYER.  
SEESAW.

No. 525,107.

Patented Aug. 28, 1894.

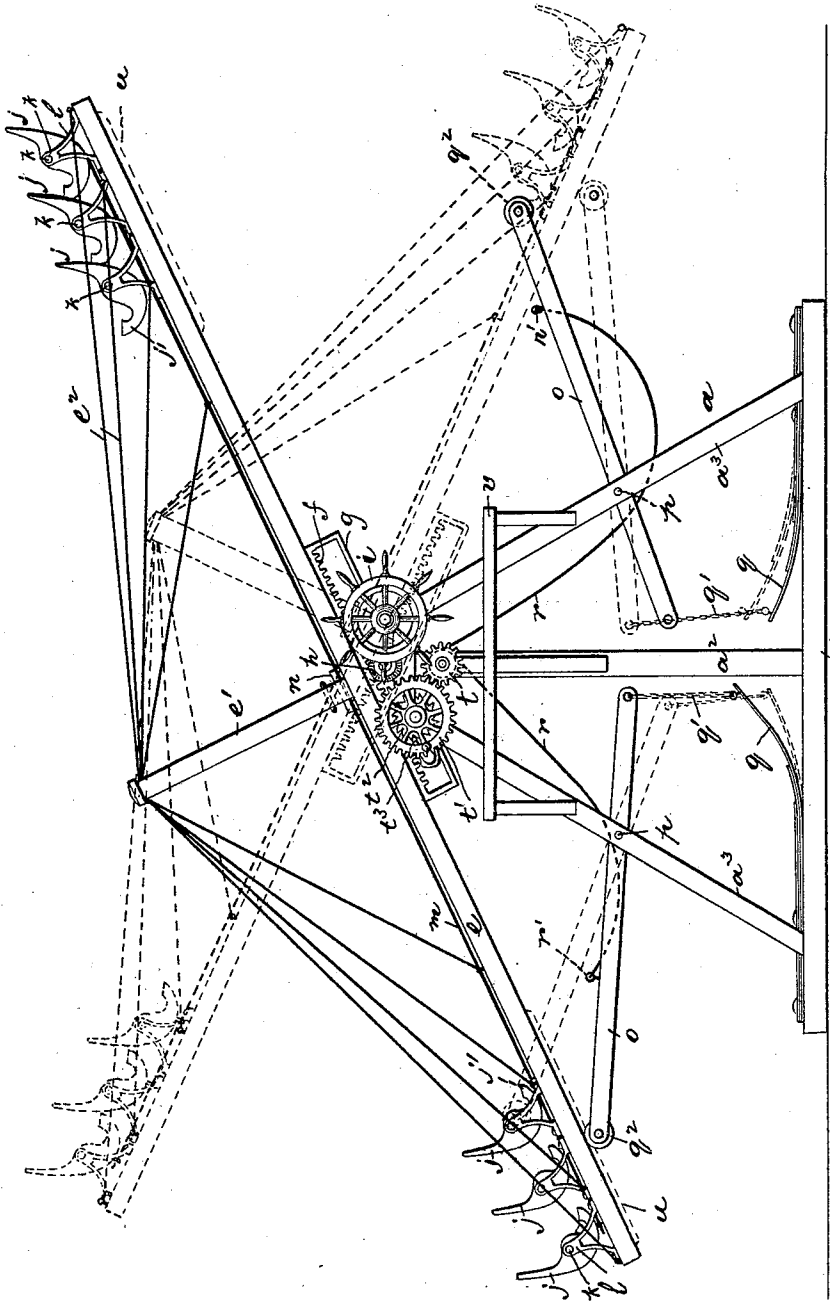

Fig. 2.

Witnesses

Inventor

Robert Solberger  
James Meyler

Maximilian Mayer,  
By Draxel & Co. Attys.

(No Model.)

3 Sheets—Sheet-3.

M. MAYER.  
SEESAW.

No. 525,107.

Patented Aug. 28, 1894.

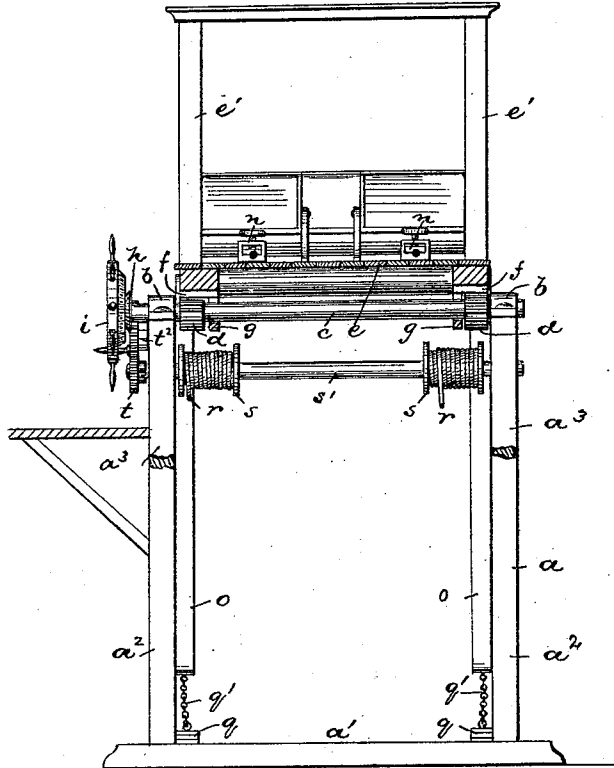

Fig 3.

Witnesses

Inventor:

Robert Sollberger  
James Meyler

Max. Mayer.

By Drackett Atty's.

# UNITED STATES PATENT OFFICE.

MAXIMILIAN MAYER, OF ORANGE, NEW JERSEY.

## SEESAW.

SPECIFICATION forming part of Letters Patent No. 525,107, dated August 28, 1894.

Application filed December 4, 1893. Serial No. 492,683. (No model.)

*To all whom it may concern:*

Be it known that I, MAXIMILIAN MAYER, a citizen of the United States, residing at Orange, in the county of Essex and State of New Jersey, have invented certain new and useful Improvements in Seesaws; and I do hereby declare the following to be a full, clear, and exact description of the invention, such as will enable others skilled in the art to which it appertains to make and use the same, reference being had to the accompanying drawings, and to letters of reference marked thereon, which form a part of this specification.

The object of this invention is to increase the pleasurable sensations common to the see-saws of older construction, to render the operation of the same on a large scale economic and easy, to facilitate the getting on or off of the machine or device and render the same easy and convenient, to provide comfortable means for seating the occupants, and to secure other advantages and results some of which will be referred to in connection with the description of the working parts.

The invention consists in the improved see-saw and in the arrangements and combinations of parts, all substantially as will be hereinafter set forth and finally embraced in the clauses of the claim.

Referring to the accompanying drawings in which like letters indicate corresponding parts in each of the figures, Figure 1 is a side elevation of the improved see-saw showing the same in position to receive the passenger or rider. Fig. 2 is a similar view showing the same in position for movement. Fig. 3 is a central vertical section through the machine.

In said drawings, *a* indicates a frame having a suitable foundation or base *a'*, standards, *a<sup>2</sup>*, and braces *a<sup>3</sup>*, at the top of which is arranged in suitable boxes or bearings, *b*, a shaft *c*, carrying cog wheels *d, d*, at opposite sides of the frame as indicated in Fig. 3. Upon said cog wheels is seated the oscillating platform, *e*, which is, especially in the larger sizes provided with king-posts, *e'*, and stays *e<sup>2</sup>*, in any suitable manner adapted to support the extremities of said platform. On the under side of said platform are racks *f, f*, which engage said cogs and move longitudinally thereon when changing the gravity center of the machine or device.

To prevent the platform from becoming disengaged from the rack or otherwise detached from the supporting frame, I have provided a guard, *g*, which is preferably cast integral with the rack, though it may be formed in pieces, and extends longitudinally parallel with the rack beneath the shaft, forming a slot for said shaft, as will be understood upon reference to Figs. 1 and 2.

On the outer end of the shaft, the same is provided with a gear wheel, *h*, which is preferably an angle gear and meshes with teeth on a hand wheel, *i*. By turning the hand wheel and the wheel, *h*, therewith, the shaft, *c*, is caused to rotate and the cog-wheels *d, d*, with it, and this action gives longitudinal movement to the reciprocating platform so that its bearing on the support is changed, as will be apparent.

The outer ends of the platform are provided with seats, *j*, for the riders and these are preferably pivoted as at *k*, upon frames, *l*, so as to oscillate on the pivots, *k*, in accordance with the oscillating platform and keep the riders in erect or comfortable positions. Said seats are coupled together by a rod, wire, rope, or similar coupling or couplings, arranged longitudinally on the platform and attached to the seats at its opposite ends. The rope moves back and forth with the bottoms of the seats as the platform oscillates. At the center of the platform, or in any other suitable position, the same is provided with a clamp, *n*, or clamps, adapted to hold the rope from lengthwise movement, and thus when the see-saw is stationary, in the horizontal position shown in Fig. 1, the passengers are enabled to step on the bottom parts, *j'*, of the seats without tilting said seats.

To hold the platform in its horizontal position, as shown in Fig. 1, I have provided the frame, *a*, with stays *o, o*, which are preferably levers fulcrumed at *p*, and fastened to springs, *q*, at their inner and lower ends by chains, or connections, *q'*. At their outer and upper ends, they are provided with antifricition rollers, *q<sup>2</sup>*, adapted to bear upon the under side of the platform. Ropes or connections, *r*, are secured, each at one end to one of the levers, *o*, as at *r'*, and, at its opposite end, is wound upon a drum, *s*, so that when said drum is turned in one direction, the rope is taken up and the lever is brought to a position nearly

vertical and so that downward movement of the adjacent end of the platform is prevented. Two drums on the one shaft,  $s'$ , work simultaneously in connection with the oppositely extending ropes and the levers connected therewith, so that oscillating movement of the platform, when both levers are nearly upright, is prevented.

The drum, or drums, are controlled by gear wheels,  $t$ , and a hand wheel,  $t'$ , having cogs meshing with said gear wheel. A ratchet wheel  $t^2$  and pawl,  $t^3$ , or other suitable device may be employed to prevent back motion of the drums when it is desired to hold the levers in their platform supporting positions.

When the ropes,  $r$ , are released and the levers drop to the positions of Fig. 2, tension is brought upon the chains,  $q'$ , and springs,  $q$ , the latter holding the levers so that they only engage the platform at or near its opposite ends when said ends are at the lower limits of reciprocation.

The downward reciprocations are stopped by said spring controlled ends and return impulses are given thereby.

The levers,  $o$ , are preferably in pairs, the antifriction rolls,  $q^2$ , extending from one to the other, and the opposite sides of the platform,  $e$ , finding a bearing on said rolls simultaneously, so that said platform will not be wrenched or distorted in its movements. I prefer to cushion the impact of the platform and rolls by means of a rubber or other cushion,  $u$ , which may be of tubing secured longitudinally upon the under sides of the sleepers or lengthwise beams of the platform in any suitable manner. Said tubes may be pneumatic or filled with confined air, or otherwise.

Upon the frame, adjacent to the hand wheels, a platform,  $v$ , is built, at which the said wheels are manipulated and the see saw controlled.

In operating the device, the same being arranged to oscillate, the attendant reciprocates the hand wheel,  $i$ , and the cogwheels connected therewith, and, as a result, the center of gravity of the platform is changed back and forth, one end overbalancing the other, at one moment, and vice versa, the next. The attendant times his movements with the action of the platform, so that the return impulses given by the springs,  $q$ , enable the center of gravity to be changed with ease even though the platform be heavy. A proper balance of the opposite ends is secured by properly centering the device before the levers,  $o$ , are fully lowered.

Having thus described the invention, what I claim as new is—

1. The improved see-saw having a rack on the under side of the vibratory platform thereof, at or near the center of gravity, cog wheels arranged on suitable bearings beneath said vibratory platform, and supporting the same, and means for changing the relations of the same, so that the center of the oscillating part

is moved back and forth, substantially as set forth.

2. The combination with the supporting frame, having cog wheels and means for turning the same reciprocally, of an oscillating platform having a longitudinal rack resting on said cog wheels, substantially as set forth.

3. The improved seesaw herein described, in which is combined with a suitable stand-ard or support, an oscillating and longitudinal reciprocating platform, the reciprocations of which induce the oscillatory movements, said platform having pivoted seats at its opposite ends, and a coupling rod connecting said seats, and means for longitudinally reciprocating the oscillating platform while the same is oscillating and thereby changing its center of gravity, substantially as set forth.

4. The combination with the oscillating platform having pivotal seats at its opposite ends, of a coupling,  $m$ , and clamp,  $n$ , substantially as set forth.

5. The improved see-saw herein described, in which is combined with the frame,  $a$ , an oscillating platform movable longitudinally back and forth on said frame whereby the center of gravity is changed while oscillating, means substantially as herein described for changing the center of gravity during the oscillatory movements, levers,  $o$ , connecting with springs,  $q$ , and said springs, substantially as and for the purposes set forth.

6. The improved see-saw herein described, in which is combined with a supporting frame,  $a$ , an oscillating platform, spring-controlled levers extending oppositely to engage the opposite ends of the see-saw, and means for raising said levers to positions to engage the under side of the platform while the same is in its horizontal position, to hold the same stationary, substantially as set forth.

7. The combination with the frame  $a$ , levers  $o$ , springs  $q$ , connections,  $q'$ , and ropes  $r$ , and a drum for winding said ropes, of an oscillating platform adapted to engage one of said levers and then the other alternately substantially as set forth.

8. The combination of the frame  $a$ , having standard,  $a^2$ , and braces,  $a^3$ , and an elevated platform,  $v$ , for the attendant, a shaft,  $c$ , having cogwheels,  $d$ , and gear wheel  $h$ , a hand-wheel  $i$ , a shaft,  $s'$ , having drums  $s$ , levers,  $o$ , having rollers  $q^2$ , ropes,  $r$ , connecting the drums and levers, a handwheel for operating the drums, a ratchet and pawl, and springs,  $q$ , and an oscillating platform having racks seated on said cog wheels and having guards,  $g$ , all said parts being arranged and adapted to operate substantially as set forth.

In testimony that I claim the foregoing I have hereunto set my hand this 29th day of November, 1893.

MAXIMILIAN MAYER.

Witnesses:

CHARLES H. PELL,  
OLIVER DRAKE.