



HU000033634T2

(19) **HU**(11) Lajstromszám: **E 033 634**(13) **T2****MAGYARORSZÁG**
Szellemi Tulajdon Nemzeti Hivatala**EURÓPAI SZABADALOM**
SZÖVEGÉNEK FORDÍTÁSA(21) Magyar ügyszám: **E 12 706732**(51) Int. Cl.: **E03B 3/28** (2006.01)(22) A bejelentés napja: **2012. 02. 06.**

(86) A nemzetközi (PCT) bejelentési szám:

PCT/US 12/023954

(96) Az európai bejelentés bejelentési száma:

EP 20120706732

(87) A nemzetközi közzétételi szám:

WO 12112325

(97) Az európai bejelentés közzétételi adatai:

EP 2675955 A1 **2012. 08. 23.**

(97) Az európai szabadalom megadásának meghirdetési adatai:

EP 2675955 B1 **2017. 03. 22.**

(30) Elsőbbségi adatok:

201161442908 P	2011. 02. 15.	US
201213365705	2012. 02. 03.	US

(73) Jogosult(ak):

LTA Corporation, New York, NY 10022 (US)

(72) Feltalálók(k):

GOELET, John, Washington, DC 20008 (US)

(74) Képviselő:

Arinova Szabadalmi és Védjegy Iroda,
Budapest

(54)

Rendszerek víz extrahálására levegőből

Az európai szabadalom ellen, megadásának az Európai Szabadalmi Közlönyben való meghirdetésétől számított kilenc hónapon belül, felszólalást lehet benyújtani az Európai Szabadalmi Hivatalnál. (Európai Szabadalmi Egyezmény 99. cikk(1))

A fordítást a szabadalmas az 1995. évi XXXIII. törvény 84/H. §-a szerint nyújtotta be. A fordítás tartalmi helyességét a Szellemi Tulajdon Nemzeti Hivatala nem vizsgálta.

(19)



(11)

EP 2 675 955 B1

(12)

EUROPEAN PATENT SPECIFICATION

(45) Date of publication and mention of the grant of the patent:
22.03.2017 Bulletin 2017/12

(21) Application number: **12706732.0**

(22) Date of filing: **06.02.2012**

(51) Int Cl.:
E03B 3/28 (2006.01)

(86) International application number:
PCT/US2012/023954

(87) International publication number:
WO 2012/112325 (23.08.2012 Gazette 2012/34)

(54) **SYSTEMS FOR WATER EXTRACTION FROM AIR**

SYSTEME ZUR WASSEREXTRAKTION AUS LUFT

SYSTÈMES POUR L'EXTRACTION DE L'EAU À PARTIR DE L'AIR

(84) Designated Contracting States:
**AL AT BE BG CH CY CZ DE DK EE ES FI FR GB
GR HR HU IE IS IT LI LT LU LV MC MK MT NL NO
PL PT RO RS SE SI SK SM TR**

(30) Priority: **15.02.2011 US 201161442908 P
03.02.2012 US 201213365705**

(43) Date of publication of application:
25.12.2013 Bulletin 2013/52

(73) Proprietor: **LTA Corporation
New York, NY 10022 (US)**

(72) Inventor: **GOELET, John
Washington, DC 20008 (US)**

(74) Representative: **Finnegan Europe LLP
16 Old Bailey
London EC4M 7EG (GB)**

(56) References cited:
WO-A1-01/36885 GB-A- 2 447 411

EP 2 675 955 B1

Note: Within nine months of the publication of the mention of the grant of the European patent in the European Patent Bulletin, any person may give notice to the European Patent Office of opposition to that patent, in accordance with the Implementing Regulations. Notice of opposition shall not be deemed to have been filed until the opposition fee has been paid. (Art. 99(1) European Patent Convention).

Description

Technical Field

[0001] The present disclosure relates generally to systems for water collection and, more particularly, to systems for water extraction from air.

Background

[0002] As the global population expands rapidly, the demand for freshwater and potable water is increasing daily at a fast rate. Natural freshwater resources, such as lakes and rivers, however, are diminishing due to destructive human activities and pollution. Furthermore, the amount of rainfall in many areas has been drastically reduced due to various influences (e.g., global warming).

[0003] One possible solution to resolve the problem of diminishing natural freshwater resources is to produce freshwater from the oceans. Various desalination technologies have been developed to produce freshwater from sea water. However, most of these technologies are bulky, energy consuming, and expensive, and therefore, are not generally affordable to many poor countries or individuals.

[0004] Water almost always exists in the air in the form of water vapor. In some humid regions, such as regions near oceans, humid air may contain a significant amount of water vapor. Various technologies have been developed to extract water from air. Many such technologies, however, require a condenser for cooling the air in order to extract water from the air. Some technologies use particular solutions to absorb water from air without requiring a condenser, but require a regenerative process (e.g., by heating) to separate the extracted water from the solutions. These prior art technologies are complex, energy consuming, and expensive. Therefore, the prior art technologies may not be affordable to people who have limited access to energy and financial resources, such as people in poor countries. Also, systems built with these prior art technologies may not be portable.

[0005] The present disclosure is directed toward improvements in existing technologies for extracting water from air.

[0006] WO 01/36885 describes an apparatus for extracting liquid water from moist air, with the features of the preamble of claim 1. This apparatus comprises a compression chamber having a variable internal volume, an intake port to allow moist air into the compression chamber, and an exhaust port to allow dried air out of the compression chamber. A wet sponge in the compression chamber provides a near-isothermal body, and serves as a scavenging device for scavenging of condensate.

Summary

[0007] In accordance with the invention, there is pro-

vided a system for water extraction from air as recited by claim 1.

[0008] In one exemplary embodiment, the present disclosure is directed to a system for water extraction from air. The system includes a housing having a plurality of openings allowing an air flow to enter into an inner space defined by the housing. The system also includes a sponge disposed within the inner space defined by the housing. The sponge includes a water absorbing/adsorbing material for absorbing/adsorbing water vapor from the air flow. The system further includes a presser disposed above the sponge and configured to compress the sponge to discharge water from the sponge.

[0009] In another exemplary embodiment, the present disclosure is directed to a system for water extraction from air. The system includes a housing having two ends with one of the two ends serving as an air inlet allowing an air flow to enter into an inner space defined by the housing, and the other one of the two ends serving as an air outlet allowing the air flow to exit the housing. The system also includes a sponge disposed within the inner space defined by the housing. The sponge includes a water absorbing/adsorbing material for absorbing/adsorbing water vapor from the air flow. The system further includes a presser disposed above the sponge and configured to compress the sponge to discharge water from the sponge.

[0010] Also disclosed herein is a system for water extraction from air, which is not part of the disclosed invention. The system includes a plurality of rotatable blades having surfaces that include a water absorbing/adsorbing material for absorbing/adsorbing water vapor from an air flow. The system also includes a ring shell structure disposed around the blades and configured to capture water droplets shed from the surfaces of the blades during rotation.

Brief Description of the Drawings

[0011]

Fig. 1 illustrates an exemplary application of a system for water extraction from air consistent with the disclosed embodiments;

Fig. 2 illustrates an exemplary system for water extraction from air consistent with the disclosed embodiments;

Fig. 3 illustrates an exemplary system for water extraction from air consistent with the disclosed embodiments;

Fig. 4 illustrates an exemplary system for water extraction from air consistent with the disclosed embodiments;

Fig. 5A illustrates an exemplary presser consistent with the disclosed embodiments;

Fig. 5B illustrates an exemplary presser consistent with the disclosed embodiments;

Fig. 5C illustrates an exemplary presser consistent

with the disclosed embodiments;
 Fig. 6A illustrates an exemplary sponge consistent with the disclosed embodiments;
 Fig. 6B illustrates an exemplary sponge consistent with the disclosed embodiments;
 Fig. 6C illustrates an exemplary sponge consistent with the disclosed embodiments;
 Fig. 7A illustrates an exemplary sponge consistent with the disclosed embodiments;
 Fig. 7B illustrates an exemplary sponge consistent with the disclosed embodiments;
 Fig. 7C illustrates an exemplary sponge consistent with the disclosed embodiments;
 Fig. 8 illustrates an exemplary system for water extraction from air consistent with the disclosed embodiments;
 Fig. 9 illustrates an exemplary double-wall structure implemented in a system for water extraction from air consistent with the disclosed embodiments;
 Fig. 10 illustrates an exemplary application of a system for water extraction from air consistent with the disclosed embodiments;
 Fig. 11 illustrates an exemplary system for water extraction from air consistent with the disclosed embodiments;
 Fig. 12 illustrates an exemplary system for water extraction from air consistent with the disclosed embodiments;
 Fig. 13 illustrates an exemplary system for water extraction from air consistent with the disclosed embodiments;
 Fig. 14 illustrates an exemplary application of a system for water extraction from air, which is not part of the disclosed invention;
 Fig. 15A illustrates an exemplary system for water extraction from air, which is not part of the disclosed invention;
 Fig. 15B illustrates a front view of a portion of the system illustrated in Fig. 15A, which is not part of the disclosed invention; and
 Fig. 16 illustrates an exemplary system for water extraction from air, which is not part of the disclosed invention.

Detailed Description

[0012] Fig. 1 illustrates an exemplary application of a system for water extraction from air consistent with the disclosed embodiments. In this exemplary application, a system 100 for extracting water from air may be a portable device that can be carried by an individual, such as a hiker, a biker, a traveler, or a soldier. System 100 may be carried by the individual by hand, or may be attached to an article carried by the individual, such as a backpack 105. System 100 may also be carried by an automobile, a bicycle, a ship, or any other moving vehicle. For example, system 100 may be attached to a portion of a bicycle. In some embodiments the attachment of system 100 to

the vehicle may be permanent. In other embodiments, the attachment may be temporary, such that system 100 may be readily detached from the vehicle, e.g., for cleaning and/or attachment to another vehicle.

[0013] Fig. 2 illustrates an exemplary embodiment of system 100 for water extraction from air. System 100 may have a canister type structure. System 100 may include a housing 110 forming the canister type structure. Housing 110 may be any suitable shape, for example, a cylinder, a cube, a hexagonal prism, a triangular prism, etc. For illustration and discussion purpose, housing 110 is shown having a cylindrical shape.

[0014] Housing 110 may be made of any suitable materials, such as steel, aluminum, alloys, composites, or plastics. Housing 110 may include a thermal insulation design, which may maintain the inner space defined by housing 110 at a relatively low temperature, or which may prevent the temperature inside the space defined by housing 110 from increasing to adversely affect the water extraction efficiency. For example, the outer surface of housing 110 may be made of, or coated with, a heat and/or sunlight reflective material, which may reflect heat and/or sunlight away from housing 110. Such material may include a reflective paint, a ceramic coating, a reflective metallic material such as aluminum, etc. Housing 110 may also include a heat insulation material between the inner and outer surfaces of housing 110, such as ceramic, foam, fiberglass, carbon fiber, etc. The inner surface of housing 110 may also include a suitable material that may help maintain a low temperature within the inner space defined by housing 110. For example, the inner surface of housing 110 may include one or more materials having a low thermal conductivity, such as ceramics, foams, carbon fiber, etc.

[0015] Housing 110 includes a plurality of openings 120, such as slots or holes on the body of housing 110. Openings 120 may serve as air inlets by allowing air to flow into the inside space defined by housing 110. Openings 120 may be distributed in a middle region of housing 110. Openings 120 may take any suitable shape, such as rectangular, square, triangular, circular, hexagonal, star-shaped, etc. Openings 120 may be evenly or randomly distributed on housing 110. The number, shape, size, and orientation of openings 120 may be determined in order to provide a desired amount and direction of air flow for the housing shape.

[0016] System 100 may include an air outlet 130 at a top end of housing 110. In some embodiments, air entering housing 110 through openings 120 may exit housing 110 from air outlet 130. Air outlet 130 may be covered by a removable end cap (not shown) when system 100 is not in operation. In some embodiments, system 100 may be provided without a separate air outlet at the top end of housing 110. For example, in certain embodiments, system 100 may be configured such that air flowing into system 100 through some of openings 120 may exit system 100 from other openings 120. For instance, in some embodiments, system 100 may be configured

such that atmospheric wind blows in openings 120 on one side of housing 110, and exits from openings 120 on the opposite side of housing 110.

[0017] System 100 includes a sponge 140 disposed inside system 100 in the space defined by housing 110. The term "sponge" used in this application represents any device having a suitable structure that is readily compressible and expandable (e.g., in the manner of an ordinary household sponge). Such devices may include a porous structure and/or a resilient and layered structure, which may be compressed to reduce volume, and then expand to substantially restore their original shapes and volumes when the compression force is released.

[0018] Sponge 140 may include a water absorbing/adsorbing material for absorbing/adsorbing water vapor from the air flow. In some embodiments, sponge 140 may be coated with the water absorbing/adsorbing material. In some embodiments, sponge 140 may be wholly or partially made of the water absorbing/adsorbing material. The water absorbing/adsorbing material may include any suitable material, for example, tertiary amines, polyethylene glycols, and/or hydrophobic activated carbon.

[0019] Sponge 140 may be configured to temporarily hold the extracted water therein. Sponge 140 is compressible. Sponge 140 is configured to, when compressed, reduce its volume, and thereby discharge water held therein. After water is discharged and the compression force released, sponge 140 may substantially restore its pre-compression volume and shape. The size of sponge 140 may be determined such that, even during the compression process, sponge 140 may avoid contact with the inner surface of housing 110. In other words, a space is always maintained between sponge 140 and the inner surface of housing 110, despite any outward (e.g., radial) expansion of sponge 140 when compressed. The space may prevent water from leaking out of housing 110, which could occur if sponge 140 were to make contact with a portion of housing 110 having openings 120 therein. In some embodiments, openings 120 may be positioned such that they are of a certain distance above the bottom of sponge 140 to prevent water leakage through openings 120 when sponge 140 is compressed.

[0020] System 100 includes a presser 150 disposed inside system 100. Presser 150 is disposed above sponge 140 and adjacent air outlet 130. Presser 150 is used to compress sponge 140 in order to discharge water from sponge 140. Presser 150 may take any suitable shape that fits the shape of housing 110. For example, presser 150 may be a round plate when housing 110 is in a cylindrical shape. Presser 150 may be movable, for example, by actuation of a presser driver 155. In some embodiments, presser driver 155 may be mechanically linked to presser 150, and may be disposed adjacent air outlet 130 on an outer surface of housing 110. In some embodiments, presser driver 155 may be slidable along a guiderail (not shown) located on the outer surface of housing 110. A user may slide presser driver 155, causing presser 150 to move towards sponge 140, and to

compress sponge 140 to discharge water. After the water is discharged from sponge 140, the user may slide presser driver 155 back to its original position adjacent air outlet 130, which in turn may bring back presser 150 to its original position adjacent air outlet 130. When presser 150 is brought to its original position, sponge 140 may expand to substantially restore its pre-compression volume and shape.

[0021] System 100 may include a water filter 160 disposed at a bottom end of housing 110. Water filter 160 may be disposed below sponge 140 and, in some embodiments, may provide a support for sponge 140. For example, in certain embodiments, sponge 140 may rest on water filter 160. Water filter 160 may include any suitable water filtering medium for cleaning water to produce potable water. When water is discharged from sponge 140, water may be filtered by water filter 160.

[0022] System 100 may also include a water tank 170 located at the bottom end of housing 110 below water filter 160 for storing water after water discharged from sponge 140 is cleaned by water filter 160. In some embodiments, water tank 170 may be removable from housing 110. For example, water tank 170 may be a threaded cap attached to housing 110 via threads. Alternatively, or additionally, water tank 170 may be attached to housing 110 via any other removable means, such as screws, clips, friction-fit, etc. The user may remove water tank 170 to access water stored therein, or to clean water tank 170 periodically. In another embodiment, water tank 170 may be an integral part of housing 110, and may not be removable from housing 110. Water tank 170 may include a valve (not shown) near the bottom position which may be opened to allow water to exit water tank 170.

[0023] Fig. 3 illustrates another exemplary system 101 for water extraction from air. System 101 includes elements that are similar to those included in system 100, such as housing 110, openings 120, air outlet 130, sponge 140, presser 150, water filter 160, and water tank 170. Therefore, the detailed descriptions of these similar elements are not repeated.

[0024] While, in some embodiments, presser driver 155 may be a mechanical driver utilizing human power (as shown and described with regard to system 100), in some embodiments, presser driver 155 may be an electro-mechanical driver utilizing electrical power, as shown and described with regard to system 101. For example, in some embodiments, presser driver 155 may be powered by a battery 190. Presser driver 155 may include a motor (not shown) or any suitable driving device for driving presser 150. Presser driver 155 may be linked with presser 150 via any suitable linking mechanism, such as a chain, a gear, or a rod. When the electrical power is supplied from battery 190 to the motor of presser driver 155, presser driver 155 may drive presser 150 to move towards filter 160 to compress sponge 140, or may drive presser 150 to move towards outlet 130.

[0025] Battery 190 may be located at any suitable location in system 101. For example, battery 190 may be

attached to housing 110 adjacent air outlet 130. In some embodiments, battery 190 may be a component separate from housing 110. For example, in some embodiments, battery 190 may be attached to housing 110 via an umbilical-type electrical connection.

[0026] As shown in Fig. 3, system 101 may also include a fan 180 located adjacent outlet 130. Fan 180 may be attached to housing 110 via any suitable supports (not shown). When electrical power is supplied from battery 190 to fan 180, fan 180 may rotate, causing an air flow from openings 120 to air outlet 130, thereby increasing the overall air flow throughout system 101. Increased air flow through sponge 140 may improve water extraction efficiency.

[0027] Fig. 4 illustrates an exemplary system 102 for water extraction from air consistent with the disclosed embodiments. System 102 includes elements similar to those included in system 100 and/or system 101, such as air outlet 130, sponge 140, presser 150, presser driver 155, water filter 160, and water tank 170. Although not shown in Fig. 4, system 102 may also include fan 180 and battery 190 as similarly included in system 101. Compared to system 100 or 101, system 102 may include a different housing 111. Housing 111 may include one or more slots provided as spiral openings 125 that allow an air flow to enter the inner space defined by housing 111. In some embodiments, spiral openings 125 may be continuous slots around the body of housing 111. Although two separate spiral openings 125 are shown in Fig. 4, housing 111 may include any suitable number of spiral openings 125 to ensure adequate air flow to sponge 140 for water extraction. In some embodiments, these spiral openings 125 may intersect with one another. One skilled in the art will appreciate that any other suitable styles may be used for the spiral openings. For example, while continuous spiral openings are shown and discussed herein, discrete openings distributed on housing 111 may alternatively, or additionally, be provided.

[0028] Air flowing into spiral openings 125 may exit from air outlet 130. One skilled in the art will appreciate that air flowing into system 102 through one spiral opening 125 may exit system 102 from another spiral opening 125 located on an opposite surface of housing 111. Thus, in some embodiments, air outlet 130 may be omitted from system 102. Similar to housing 110, housing 111 may include a thermal insulation design, which may maintain the inner space defined by housing 111 at a relatively low temperature, or which may prevent the temperature inside the space defined by housing 111 from increasing to adversely affect the water extraction efficiency. For example, the outer surface of housing 111 may be coated with a highly reflective material, which may reflect heat away from housing 111. The inner surface of housing 111 may also include a suitable material that may help maintain a low temperature within the inner space defined by housing 111. Further details about exemplary thermal regulation features are discussed above.

[0029] Figs. 5A-5C illustrate exemplary designs of

presser 150 consistent with the disclosed embodiments. Presser 150 is shown in a round shape in Figs. 5A-5C, which may be employed with a cylindrical housing 110 or 111. As shown in Fig. 5A, in some embodiments, presser 150 may be a solid plate. A solid plate presser structure, such as shown in Fig. 5A, may be employed in embodiments, such as systems 100 and 102, where air entering from some openings located on the housing may exit from other openings located on the housing, rather than from air outlet 130.

[0030] As shown in Fig. 5B, in another embodiment, presser 150 may have a plate structure having a plurality of openings 151. The number, distribution, and shape of openings 151 may be suitably designed such that presser 150 does not block air flow from openings 120 or spiral openings 125 to air outlet 130.

[0031] As shown in Fig. 5C, presser 150 may have a screen shape structure having a web 152. Web 152 may allow free air flow from openings 120 or spiral openings 125 to air outlet 130. Web 152 may be designed strong for compressing sponge 140. One skilled in the art will appreciate that other suitable presser configurations may be employed in systems 100, 101, and 102.

[0032] Figs. 6A-6C illustrate exemplary designs of sponge 140 consistent with the disclosed embodiments. As shown in Fig. 6A, sponge 140 may be in a cylindrical shape, having a plurality of pores 141 evenly or randomly distributed within the structure. Sponge 140 may be made of any suitable materials, such as polymer, paper, cotton fabric, etc. Sponge 140 may include a water absorbing/adsorbing material. In some embodiments, sponge 140 may be coated with the water absorbing/adsorbing material. In some embodiments, sponge 140 may be wholly or partially made of the water absorbing/adsorbing material. The water absorbing/adsorbing material may include any suitable material, for example, tertiary amines, polyethylene glycols, and/or hydrophobic activated carbons. The water absorbing/adsorbing material may enable sponge 140 to extract water vapor from an air flow passing over the surface and/or through sponge 140. Water extracted from air may be held within sponge 140. When compressed, the volume of sponge 140 may be reduced, causing the discharge of water held therein. When the compression force is released, sponge 140 may restore its pre-compression volume and shape due to the resilience of its structure.

[0033] In some embodiments, sponge 140 may have a layered structure connected through links 145, as shown in Fig. 6B. Sponge 140 shown in Fig. 6B may include a plurality of layers 142, 143, and 144. Links 145 may provide support to the layers. Links 145 may also be elastic or resilient so that they do not severely interfere with the compression of sponge 140. When the compression force is released, elastic links 145 may help sponge 140 to restore the pre-compression volume and shape of sponge 140.

[0034] Although three layers are shown in Fig. 6B, any suitable number of layers may be used. In some embod-

iments, one or more of layers 143, 143, and 144 may be in the form of a block structure, similar to the structure shown in Fig. 6A.

[0035] In yet another embodiment shown in Fig. 6C, sponge 140 may include a block structure having a body filled with a plurality of fibers 146. Fibers 146 may be organized in a regular pattern, or may be disposed within the body of sponge 140 randomly. Fibers 146 may be resilient, which may help sponge 140 in the compression and expansion processes. Fibers 146 may include a water absorbing/adsorbing material. In some embodiments, fibers 146 may be coated with the water absorbing/adsorbing material. In other embodiments, fibers 146 may be wholly or partially made of the water absorbing/adsorbing material. The water absorbing/adsorbing material may include any suitable material, for example, tertiary amines, polyethylene glycols, and/or hydrophobic activated carbons. Water extracted from air may attach to fibers 146 and be temporarily held within sponge 140.

[0036] Figs. 7A-7C illustrate cross-sectional views of exemplary sponge designs consistent with the disclosed embodiments. These designs correspond to Figs. 6A-6C, except that the surfaces of sponge 140 include a ribbed, corrugated, or ridged surface 147. Surface 147 may be coated with or made of, the same water absorbing/adsorbing material used for other parts of sponge 140. Thus, surface 147 may increase the overall surface area exposure to the air flow, thereby increasing the water extraction efficiency.

[0037] Fig. 8 illustrates an exemplary system 103 for water extraction from air consistent with the disclosed embodiments. System 103 may include similar elements as systems 100, 101, and 102. For simplicity, some elements such as presser 150, presser driver 155, fan 180, and battery 190 are not shown in Fig. 8, although these components may be included in system 103. Fig. 8 shows a double-wall structure which may be employed to housing 110 or housing 111. For purposes of illustration, the double-wall structure shown in Fig. 8 is depicted as implemented in housing 110.

[0038] As shown in Fig. 8, housing 110 may include an outer wall 161 and an inner wall 162. A space may be maintained between outer wall 161 and inner wall 162. Sponge 140 may be disposed within a space defined by inner wall 162. Housing 110 includes a plurality of openings 171 on outer wall 161, and a plurality of openings 172 on inner wall 162. Openings 171 and 172 may be through-holes or slots, and may be similar to openings 120 shown in Fig. 2, or spiral openings 125 shown in Fig. 4. Inner wall 162 may limit the expansion of sponge 140 during compression, such that sponge 140 does not touch outer wall 161 when compressed, thereby preventing water from leaking through openings 171 on outer wall 161.

[0039] Openings 171 and 172 may serve as air inlets, allowing air to flow into and out of sponge 140. Openings 172 on inner wall 162 may also allow water discharged from sponge 140 during the compression process to flow

into the space between inner wall 162 and outer wall 161. Water filter 160 may be disposed at the bottom of inner wall 162, and may clean water discharged from sponge 140. In some embodiments, inner wall 162 and sponge 140 may rest on water filter 160. Water filter 160 may extend to cover the space between inner wall 162 and outer wall 161. Thus, water flowing out of inner wall 162 into the space between inner wall 162 and outer wall 161 may also be filtered by water filter 160 before entering into water tank 170.

[0040] Fig. 9 illustrates an exemplary double-wall structure that may be implemented in system 103. In this embodiment, system 103 may include flanges 173 extending from openings 171 on outer wall 161. Flanges 173 may extend inwardly towards inner wall 162 from an upper edge of openings 171. When sponge 140 is compressed and when water is flowing out of inner wall 162 through openings 172, flanges 173 may prevent water from leaking out of system 103 through openings 171 on outer wall 161. Flanges 173 may be configured in such a way as to prevent water leakage, yet still allow free air flow. Although not shown in Fig. 9, one skilled in the art will appreciate that inner wall 162 may also include similar flanges at openings 172.

[0041] Fig. 10 illustrates an exemplary application of a system for water extraction from air consistent with the disclosed embodiments. In such an application, a system 200 may have a relatively large volume for producing a relatively large amount of water, as compared to systems 100-103. System 200 may be fixed on a farm for extracting water from air for feeding people and animals. In some embodiments, system 200 may be rendered portable, e.g., by being mounted on a truck.

[0042] Fig. 11 illustrates exemplary details of system 200. As shown in Fig. 11, system 200 may include a housing 210. Housing 210 may be made of any suitable material, such as plastic or metal. Similar to housing 110 and 111, housing 210 may include a thermal insulation feature, which may maintain the inner space defined by housing 210 at a relatively low temperature, or which may prevent the temperature inside the space defined by housing 210 from increasing to adversely affect the water extraction efficiency. For example, the outer surface of housing 210 may be coated with a highly reflective material, which may reflect heat away from housing 210. The inner surface of housing 210 may also include a suitable material that may help maintain a low temperature within the inner space defined by housing 210. Additional details of possible thermal regulating features are discussed above.

[0043] Housing 210 may include a longitudinally extended body having two open ends. In some embodiments, air may flow into and out of system 200 via the two open ends of housing 210. Air may flow into system 200 from either open end of housing 210. For example, air may flow into system 200 from opening 220, and flow out of system 200 from opening 230. Air may also flow in the reverse direction, i.e., in opening 230 and out open-

ing 220.

[0044] System 200 may include an air filter 240 disposed at one or both of openings 220 and 230. System 200 includes a sponge 260 having a structure and property similar to those of sponge 140 discussed above. Sponge 260 may extract water vapor from air as air flows through sponge 260 and store extracted water therein. Although sponge 260 is shown in a single configuration, sponge 260 may have any of the features discussed above with respect to sponge 140.

[0045] System 200 includes a presser 290 configured to compress sponge 260 to discharge water from sponge 260. Presser 290 may be similar to presser 150 discussed above. Presser 290 may be driven by a handle 295 attached to housing 210. Handle 295 may be mechanically linked to presser 290 through any suitable mechanism, such as chains, gears, and springs. Handle 295 may be operable without any electrical power. A user of system 200 may actuate handle 295 by pulling down handle 295 to move presser 290 downward to compress sponge 260. The user may also move handle 295 to bring presser 290 back to its original position after water is discharged out of sponge 260.

[0046] System 200 may include a water filter 270 located below sponge 260. Water filter 270 may be similar to water filter 160 discussed above. Water discharged from sponge 260 may be filtered by water filter 270. Filtered water may flow into a water tank 280 located below water filter 270. Water tank 280 may be an integral part of housing 210, or may be a separate part that may be removed from and attached to housing 210. In some embodiments, system 200 may be fixed to a building or the ground through supports 285.

[0047] Fig. 12 illustrates another exemplary system 202 for water extraction from air consistent with the disclosed embodiments. System 202 may include elements similar to those shown in system 200. The similar elements are labeled with the same numerical references as those included in system 200. Accordingly, the details of these similar elements may be referenced above.

[0048] In system 202, presser 290 may be driven by a motor 300, which may be powered by a battery 310. Motor 300 and battery 310 may be attached to housing 210 at suitable locations. Motor 300 may be linked with presser 290 through a suitable linking mechanism, such as a chain, a gear, or an extendable and extractable rod. When electrical power is supplied from battery 310 to motor 300, motor 300 may drive presser 290 towards sponge 260 to compress sponge 260. After water is discharged from sponge 260, motor 300 may bring presser 290 back to its original position.

[0049] Fig. 13 illustrates an exemplary system 203 for extracting water from air consistent with the disclosed embodiments. System 203 may include elements similar to those included in systems 200 and 202. These similar elements are labeled with the same numerical references as those in systems 200 and 202. The details of these similar elements may be referenced above.

[0050] In system 203, a presser 290 may be driven by a motor 300. Motor 300 may in turn be powered by a solar panel 320. Solar panel 320 may be attached to housing 210 through a fixture 325. Alternatively, solar panel 320 may be separate from housing 210. Solar panel 320 may convert solar energy into electrical energy, and may store electrical energy in a power storage device 330, such as a battery. Power storage device 330 may be electrically connected with motor 300 to supply electrical power to motor 300.

[0051] Fig. 14 illustrates another exemplary application of a system for water extraction from air, which is not part of the disclosed invention.

[0052] As shown in Fig. 14, a system 400 for extracting water from air may be integral with a windmill structure. System 400 may be used for generating electricity from wind power and, at the same time, extracting water from air. For example, system 400 may be disposed on a farm, adjacent a house, on an ocean island, or on a cruise ship to generate both electrical energy and potable water.

[0053] Fig. 15A illustrates further exemplary details of system 400. System 400 may include a windmill 410. Windmill 410 may include a plurality of blades 420. As wind blows through windmill 410, blades 420 may be driven by the wind to rotate, thereby converting wind energy into electrical energy through an energy converting unit included in the windmill 410 (not shown). Any type of energy converting unit known in the art may be suitable for use in system 400. System 400 may further include a ring shell structure 430 surrounding blades 420. Ring shell structure 430 may be attached to windmill 410 through supporting structures 440. At a bottom portion of ring shell structure 430, system 400 may include a water collector 450, which may be connected to a water tank 470 through a conduit 460.

[0054] The surface shape and area of blades 420 may be configured to provide, when rotating, a desired amount of air flow passing over fan blades 420. Thus, the goals of maximizing the speed of rotation for harvesting energy from the wind, and maximizing the blade surface area and wind flow thereover to promote extraction of water from the air, may be considered. The development of blade shapes may be facilitated using suitable design and/or simulation software and/or through experimentation.

[0055] Surfaces of blades 420 may include a water absorbing/adsorbing material. In some examples, at least a portion of blades 420 may be made of a water absorbing/adsorbing material. In some examples, part, or all, of each blade 420 may be made of a water absorbing/adsorbing material. In other examples, the surface of blades 420 may include a water absorbing/adsorbing material. For example, each of blades 420 may include a top layer that forms the surface, and the top layer may include a water absorbing/adsorbing material, such as a coating, laminate, etc. The water absorbing/adsorbing material may include any suitable material, for example, tertiary amines, polyethylene glycols, and/or hydrophobic acti-

vated carbons. As wind blows across the surfaces of blades 420, water vapor within the air may be extracted by the water absorbing/adsorbing material of blades 420.

[0056] As illustrated in Fig. 15B, water extracted from the air may attach to the surfaces of blades 420 in the form of water droplets 455. Water droplets 455 may grow as water accumulates on the surfaces of blades 420. In some examples, the surface of blades 420 may include a texture that facilitates the formation of water droplets thereon. When blades 420 rotate, water droplets 455 may be shed off the blades 420 due to the centrifugal forces caused by the rotation. Water droplets 455 shed off from blades 420 during rotation may be captured by ring shell structure 430, and may flow to the bottom position of ring shell structure 430. Water droplets 455 may be collected in water collector 450 located at the bottom position of ring shell structure 430. Water collected in water collector 450 may be further transported to water tank 470 for storage through conduit 460.

[0057] Fig. 16 illustrates an exemplary system 500 for water extraction from air consistent with the disclosed examples, which is not part of the disclosed invention. Rather than including a windmill, system 500 may include a fan 510. In some examples, fan 510 may be portable. Thus, in such examples, system 500 may be conveniently carried by an individual 505, such as a soldier or a traveler. Individual 505 may temporarily attach portable fan 510 to a structure erected on the ground, such as a post 580. In some examples, fan 510 may be fixed, e.g., to a building structure.

[0058] System 500 may include a plurality of blades 520 and a ring shell structure 530. Ring shell structure 530 may be attached to fan 510 through a plurality of supporting structures 540. System 500 may include a water collector 550 located at a bottom position of ring shell structure 530. Water collector 550 may be connected with a water tank 570 through a conduit 560. System 500 may further include a power supply 590, such as a battery, connected with fan 510 for driving blades 520. Power supply 590 may supply electrical power to a motor (not shown), which may drive blades 520 to rotate.

[0059] In some examples, fan 510 may be operable to extract water from air even when not in use to blow air for a particular purpose. For example, in some examples, fan 510 may be passively spun by the wind, much like a windmill, except without the energy harvesting feature. In such examples, in order to sustain the water extraction action even during periods of minimal wind, power supply 590 may be configured to only supply power to drive blades 520 when the rotating speed of blades 520 is below a predetermined threshold speed. When blades 520 are rotating above the threshold speed, power supply 590 may remain inactive, allowing the wind to pass the air over blades 520 to facilitate the water extraction process.

[0060] Similar to blades 420 in system 400, blades 520 may include a water absorbing/adsorbing material. As wind blows across the surfaces of blades 520, water va-

por may be extracted from the air by the water absorbing/adsorbing material. Water extracted from the air may form water droplets, which may attach to the surfaces of blades 520. In some examples, the surface of blades 520 may include a texture that facilitates the formation of water droplets thereon. As water droplets grow, they may be shed off from blades 520 due to the centrifugal forces. Water droplets shed off from blades 520 during rotation may be received by ring shell structure 530. Water droplets may flow to the bottom portion of ring shell structure 530, and may be collected by water collector 550. Water collected by water collector 550 may be further transported to water tank 570 for storage through conduit 560.

[0061] The disclosed systems for extracting water from air may have a wide variety of applications. For example, the disclosed systems may be carried by an individual, such as a soldier in a war zone, a traveler in a desert or a tropical forest. The disclosed system may also be carried by an automobile, a bike, or a ship. In some applications, the disclosed systems may also be employed on a farm, a sea shore, an off-shore oil rig, or a rooftop of a building. The disclosed systems may operate without any external power supply, may utilize power supplied by a solar panel, and/or may require only small amount of power for operation.

[0062] It will be apparent to those skilled in the art that various modifications and variations can be made in the disclosed systems for extracting water from air. Other embodiments will be apparent to those skilled in the art from consideration of the specification and practice of the disclosed embodiments herein. It is intended that the specification and examples be considered as exemplary only, with a true scope of the disclosure being indicated by the following claims.

Claims

1. A system (100; 102; 103; 200; 202; 203) for water extraction from air, comprising:

a housing (110; 111; 210); and
a sponge (140; 260) disposed within an inner space defined by the housing (110; 111; 210), the sponge including a water absorbing/adsorbing material for absorbing/adsorbing water vapor from an air flow in the inner space; and a presser, **characterised in that:**

the housing (110; 111; 210) comprises a plurality of openings (120; 125; 171, 172) for allowing the air flow to enter into the inner space defined by the housing; and **in that** the presser (150; 290) is disposed above the sponge (140; 260) and configured to compress the sponge to discharge water from the sponge.

2. The system of claim 1, further comprising:
a presser driver (155; 295) configured to utilize human power to drive the presser (150; 290).
3. The system of claim 1, further comprising:
a presser driver (155; 300) configured to utilize an electrical power supply (190; 310; 320, 330) to drive the presser (150; 290).
4. The system of claim 1, further comprising:
a fan (180) disposed at an end position of the housing (110; 111) and configured to receive power from an electrical power supply (190).
5. The system of claim 1, further comprising:
a water filter (160; 270) disposed below the sponge (140; 260) for filtering water discharged from the sponge; and
a water tank (170; 280) disposed below the water filter (160; 270) for storing water discharged from the sponge (140; 260) and filtered by the water filter.
6. The system of claim 1, wherein the plurality of openings in the housing (111) include a plurality of spiral openings (125).
7. The system of claim 1, wherein the presser (150) has a web structure (152).
8. The system of claim 1, wherein the sponge (140) has a block structure.
9. The system of claim 1, wherein the sponge (140) has a layered structure including a plurality of layers (142, 143, 144).
10. The system of claim 1, wherein the sponge (140) includes a plurality of fibers (146) within a body of the sponge.
11. The system of claim 1, wherein:
the sponge (140) includes a ribbed, corrugated, or ridged surface (147).
12. The system of claim 1, wherein:
the housing (110; 111) includes a double-wall structure having an inner wall (162) and an outer wall (161),
wherein the sponge (140) is disposed within a space defined by the inner wall (162), and
wherein the inner wall (162) and the outer wall (161) each include a plurality of openings (171, 172).
13. The system of claim 12, wherein:
the housing (110; 111) includes a plurality of flanges (172) extending inwardly toward the inner wall (162) from the plurality of openings (171) located on the outer wall (161).
14. The system of claim 1, wherein the housing (200) has two ends with one of the two ends serving as an air inlet (230) allowing the air flow to enter into the inner space defined by the housing, and the other one of the two ends serving as an air outlet (230) allowing the air flow to exit the housing.
15. The system of claim 14, further comprising:
a handle (295) attached to the housing (210) and mechanically linked to the presser (290).
16. The system of claim 14, further comprising:
a motor (300) configured to drive the presser (290);
a battery (310) configured to provide electrical power to the motor (300).
17. The system of claim 14, further comprising:
a motor (300) configured to drive the presser (290);
a solar panel (320) configured to convert solar energy into electrical energy; and
a power storage device (330) configured to store electrical energy converted by the solar panel (320), and to supply electrical power to the motor (300).

Patentansprüche

1. System (100; 102; 103; 200; 202; 203) zur Wasserextraktion aus der Luft, umfassend:
ein Gehäuse (110; 111; 210); und
einen Schwamm (140; 260), der innerhalb eines Innenraums angeordnet ist, der durch das Gehäuse (110; 111; 210) definiert ist, wobei der Schwamm ein Wasser absorbierendes/adsorbierendes Material zum Absorbieren/Adsorbieren von Wasserdampf von einem Luftstrom in dem Innenraum enthält;
und einen Drücker, **dadurch gekennzeichnet, dass:**
das Gehäuse (110; 111; 210) eine Vielzahl

- von Öffnungen (120; 125; 171; 172) umfasst, um zu ermöglichen, dass der Luftstrom in den Innenraum, der durch das Gehäuse definiert ist, eintritt; und dass der Drücker (150; 290) über dem Schwamm (140; 260) angeordnet und dazu ausgelegt ist, den Schwamm zu komprimieren, um Wasser von dem Schwamm auszugeben.
- 2.** System nach Anspruch 1, ferner umfassend:
- einen Drückerantrieb (155; 295), der dazu ausgelegt ist, Menschenkraft zu verwenden, um den Drücker (150; 290) anzutreiben.
- 3.** System nach Anspruch 1, ferner umfassend:
- einen Drückerantrieb (155; 300), der dazu ausgelegt ist, eine elektrische Stromversorgung (190; 310; 320; 330) zu verwenden, um den Drücker (150; 290) anzutreiben.
- 4.** System nach Anspruch 1, ferner umfassend:
- ein Gebläse (180), das an einer Endposition des Gehäuses (110; 111) angeordnet und dazu ausgelegt ist, Strom von einer elektrischen Stromversorgung (190) zu empfangen.
- 5.** System nach Anspruch 1, ferner umfassend:
- einen Wasserfilter (160; 270), der unter dem Schwamm (140; 260) angeordnet ist, um Wasser zu filtern, das von dem Schwamm ausgegeben wird; und
einen Wassertank (170; 280), der unter dem Wasserfilter (160; 270) angeordnet ist, um Wasser zu speichern, das von dem Schwamm (140; 260) ausgegeben wird und von dem Wasserfilter gefiltert wird.
- 6.** System nach Anspruch 1, wobei die Vielzahl von Öffnungen in dem Gehäuse (111) eine Vielzahl von spiralförmigen Öffnungen (125) enthält.
- 7.** System nach Anspruch 1, wobei der Drücker (150) eine Bahnstruktur (152) aufweist.
- 8.** System nach Anspruch 1, wobei der Schwamm (140) eine Blockstruktur aufweist.
- 9.** System nach Anspruch 1, wobei der Schwamm (140) eine Schichtstruktur aufweist, die eine Vielzahl von Schichten (142; 143; 144) enthält.
- 10.** System nach Anspruch 1, wobei der Schwamm (140) eine Vielzahl von Fasern (146) innerhalb eines
- Körpers des Schwamms enthält.
- 11.** System nach Anspruch 1, wobei:
- der Schwamm (140) eine gerippte, gewellte oder gerippte Oberfläche (147) enthält.
- 12.** System nach Anspruch 1, wobei:
- das Gehäuse (110; 111) eine Doppelwandstruktur enthält, die eine Innenwand (162) und eine Außenwand (161) aufweist, wobei der Schwamm (140) innerhalb eines Raums angeordnet ist, der durch die Innenwand (162) definiert ist, und wobei die Innenwand (162) und die Außenwand (161) jeweils eine Vielzahl von Öffnungen (171; 172) enthalten.
- 13.** System nach Anspruch 12, wobei:
- das Gehäuse (110; 111) eine Vielzahl von Flanschen (172) enthält, die sich nach innen zu der Innenwand (162) von der Vielzahl von Öffnungen (171) erstrecken, die sich an der Außenwand (161) befinden.
- 14.** System nach Anspruch 1, wobei das Gehäuse (200) zwei Enden aufweist, wobei eines der zwei Enden als ein Lufteinlass (230) dient, der ermöglicht, dass der Luftstrom in den Innenraum, der durch das Gehäuse definiert ist, eintritt, und das andere Ende der zwei Enden als ein Luftauslass (230) dient, der ermöglicht, dass der Luftstrom das Gehäuse verlässt.
- 15.** System nach Anspruch 14, ferner umfassend:
- einen Griff (295), der an dem Gehäuse (210) befestigt ist und mechanisch mit dem Drücker (290) verbunden ist.
- 16.** System nach Anspruch 14, ferner umfassend:
- einen Motor (300), der dazu ausgelegt ist, den Drücker (290) anzutreiben;
eine Batterie (310), die dazu ausgelegt ist, dem Motor (300) elektrischen Strom zu liefern.
- 17.** System nach Anspruch 14, ferner umfassend:
- einen Motor (300), der dazu ausgelegt ist, den Drücker (290) anzutreiben;
einen Sonnenkollektor (320), der dazu ausgelegt ist, Sonnenenergie in elektrische Energie umzuwandeln; und
eine Energiespeichervorrichtung (330), die dazu ausgelegt ist, elektrische Energie zu speichern, die von dem Sonnenkollektor (320) um-

gewandelt wurde, und dem Motor (300) elektrischen Strom zu liefern.

Revendications

1. Système (100, 102, 103, 200, 202, 203) d'extraction de l'eau de l'air, comprenant :

un boîtier (110, 111, 210); et
une éponge (140, 260) disposée dans un espace interne défini par le boîtier (110, 111, 210), l'éponge comprenant une matière d'absorption/adsorption d'eau pour absorption/adsorption de la vapeur d'eau dans un débit d'air dans l'espace interne ;
et un compresseur,

caractérisé en ce que :

le boîtier (110, 111, 210) comprend une pluralité d'ouvertures (120, 125, 171, 172) permettant l'introduction du débit d'air dans l'espace interne défini par le boîtier ; et

et en ce que

le compresseur (150, 290) est disposé au-dessus de l'éponge (140, 260) et configuré pour comprimer l'éponge et décharger l'eau provenant de l'éponge.

2. Système selon la revendication 1, comprenant en outre :

une commande de compresseur (155, 295) configurée pour utiliser l'énergie de l'homme pour l'entraînement du compresseur (150, 290).

3. Système selon la revendication 1, comprenant en outre :

une commande de compresseur (155, 300) configurée pour utiliser une fourniture d'électricité (190, 310, 320, 330) pour l'entraînement du compresseur (150, 290).

4. Système selon la revendication 1, comprenant en outre :

un ventilateur (180) placé sur une extrémité du boîtier (110, 111) et configuré pour recevoir l'alimentation électrique d'une fourniture d'électricité (190).

5. Système selon la revendication 1, comprenant en outre :

un filtre d'eau (160, 270) disposé sous l'éponge (140, 260) pour filtrer l'eau déchargée par

l'éponge ; et

un réservoir d'eau (170, 280) disposé sous le filtre d'eau (160, 270) pour stocker l'eau déchargée par l'éponge (140, 260) et filtrée par le filtre d'eau.

6. Système selon la revendication 1, la pluralité d'ouvertures dans le boîtier (111) comprenant une pluralité d'ouvertures spiralées (125).

7. Système selon la revendication 1, le compresseur (150) présentant une structure en treillis (152).

8. Système selon la revendication 1, l'éponge (140) présentant une structure en bloc.

9. Système selon la revendication 1, l'éponge (140) présentant une structure en couches, composée d'une pluralité de couches (142, 143, 144).

10. Système selon la revendication 1, l'éponge (140) comprenant une pluralité de fibres (146) au sein d'un corps de l'éponge.

11. Système selon la revendication 1, dans lequel :

l'éponge (140) comprend une surface nervurée, ondulée ou striée (147).

12. Système selon la revendication 1, dans lequel :

le boîtier (110, 111) comprend une structure à double paroi, avec une paroi interne (162) et une paroi externe (161),
l'éponge (140) étant disposée dans un espace défini par la paroi interne (162), et
la paroi interne (162) et la paroi externe (161) comprenant chacune une pluralité d'ouvertures (171, 172).

13. Système selon la revendication 12, dans lequel :

le boîtier (110, 111) comprend une pluralité de brides (172) s'étendant vers l'intérieur en direction de la paroi interne (162) depuis la pluralité d'ouvertures (171) situées sur la paroi externe (161).

14. Système selon la revendication 1, le boîtier (200) présentant deux extrémités, dont une sert d'entrée d'air (230) en admettant le débit d'air dans l'espace interne défini par le boîtier, l'autre des deux extrémités servant de sortie d'air (230) et permettant le re-foulement de l'air hors du boîtier.

15. Système selon la revendication 14, comprenant en outre :

une poignée (295) fixée sur le boîtier (210) et raccordée mécaniquement au compresseur (290).

16. Système selon la revendication 14, comprenant en outre : 5

un moteur (300) configuré pour entraîner le compresseur (290) ;
une batterie (310) configurée pour assurer l'alimentation électrique du moteur (300). 10

17. Système selon la revendication 14, comprenant en outre : 15

un moteur (300) configuré pour entraîner le compresseur (290) ;
un panneau solaire (320) configuré pour convertir l'énergie solaire en énergie électrique ; et
un dispositif de stockage d'énergie (330) configuré pour stocker l'énergie électrique convertie par le panneau solaire (320), et assurer l'alimentation électrique au moteur (300). 20

25

30

35

40

45

50

55

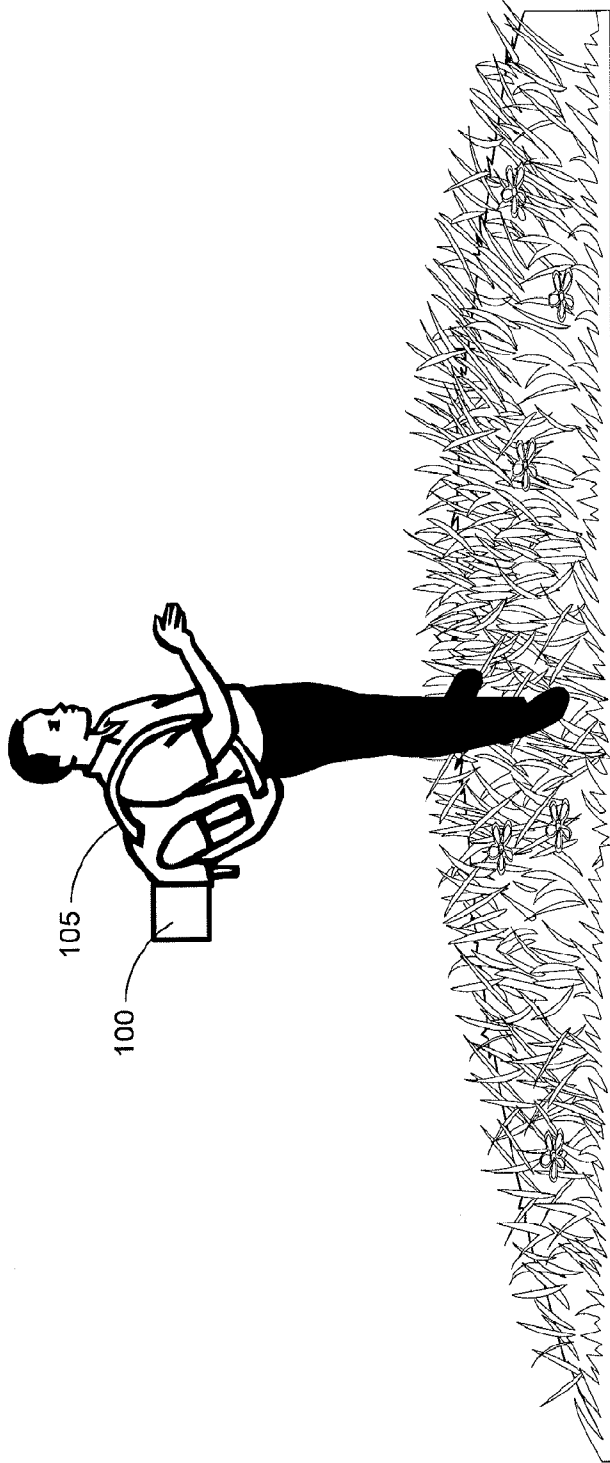
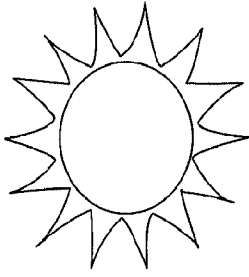

FIG. 1

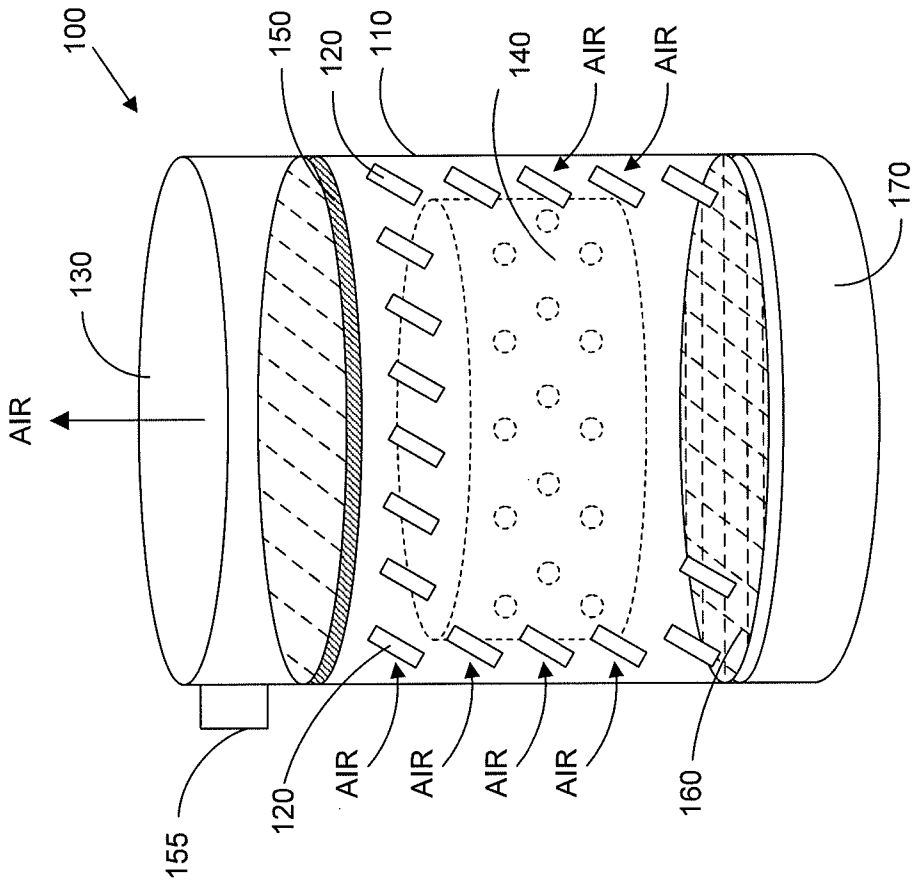

FIG. 2

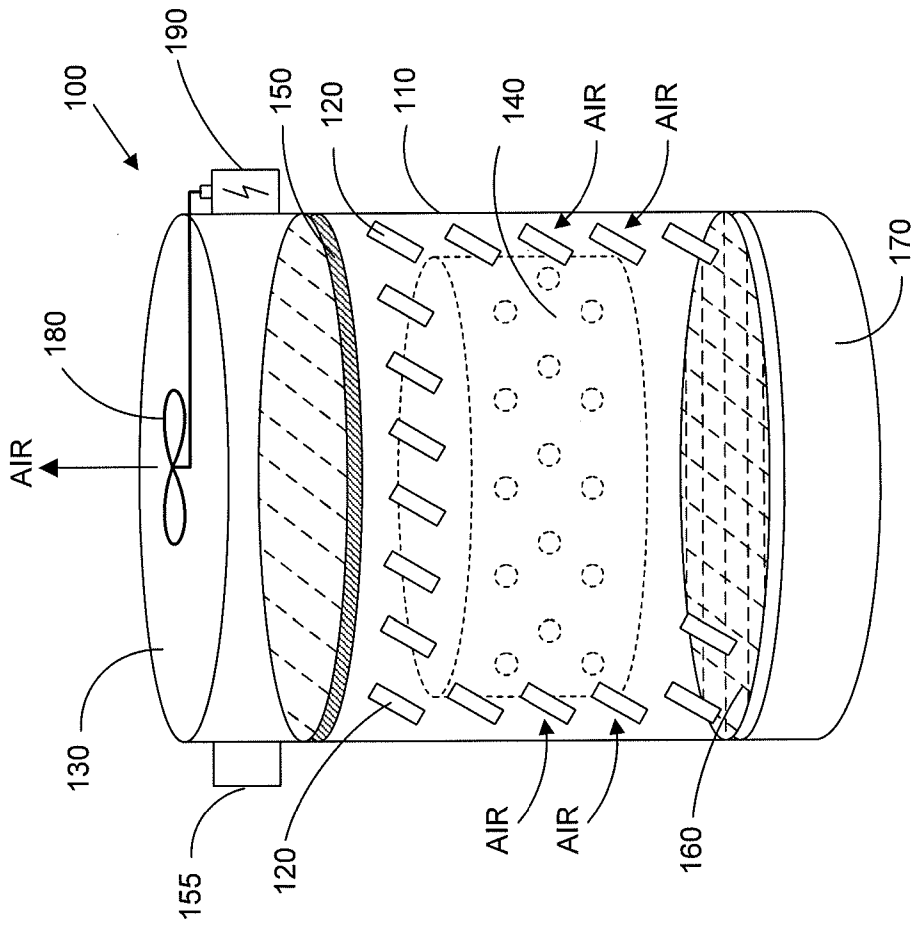

FIG. 3

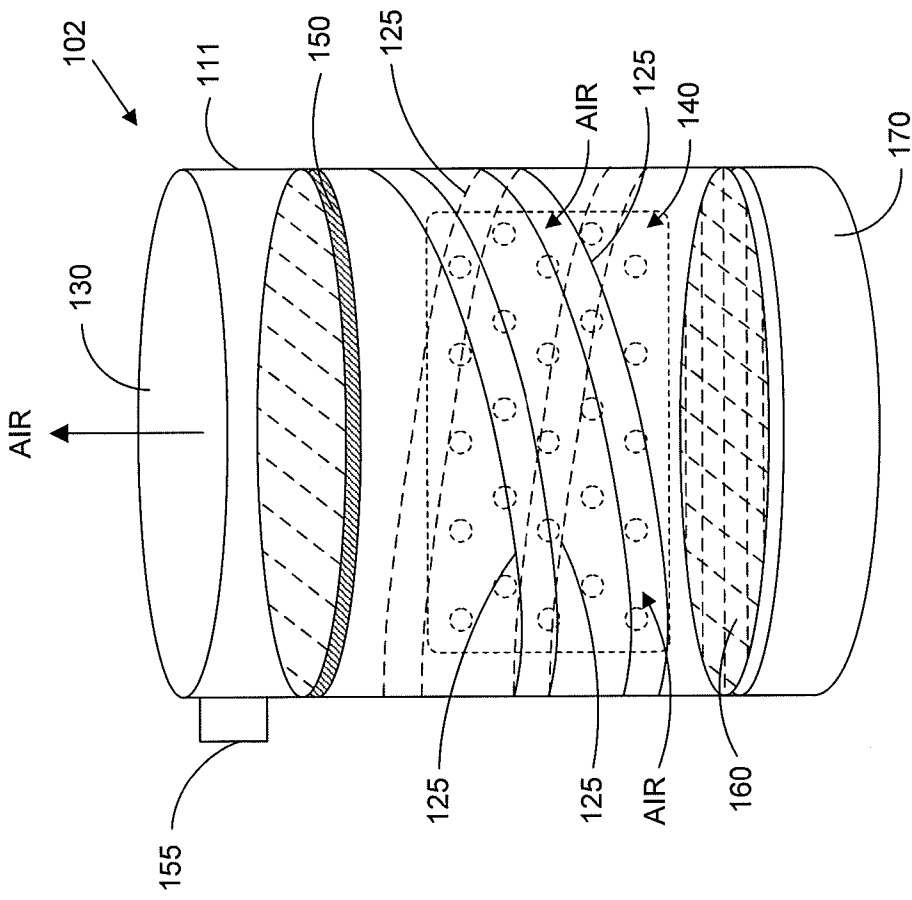

FIG. 4

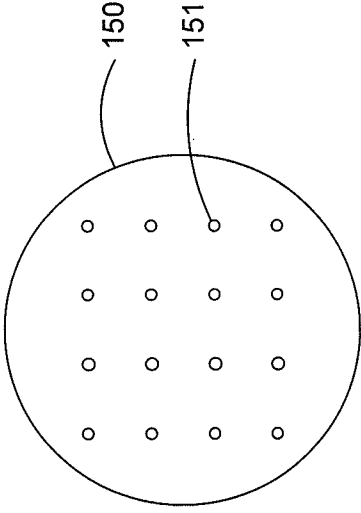

FIG. 5B

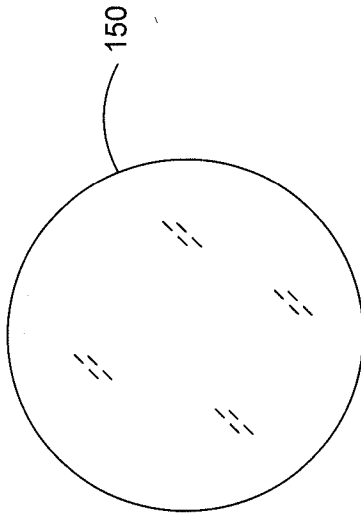

FIG. 5A

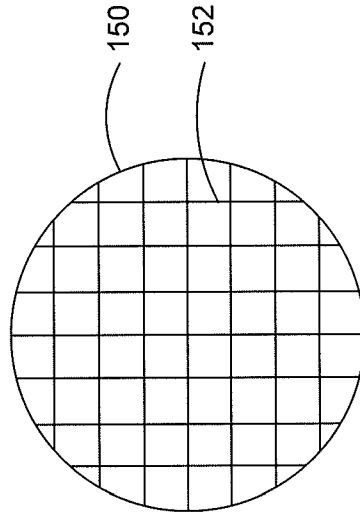

FIG. 5C

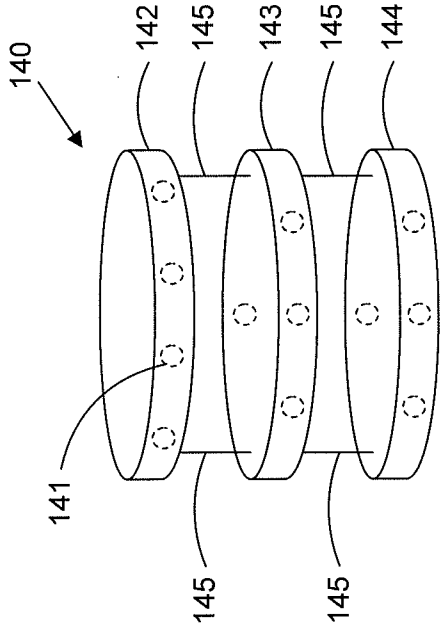

FIG. 6B

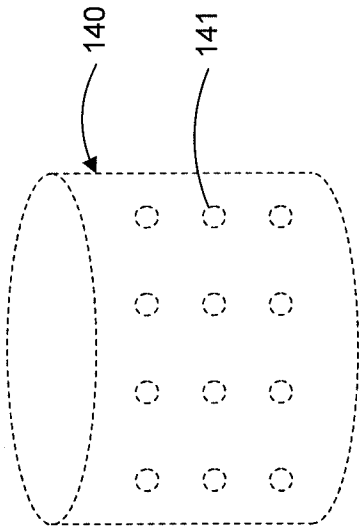

FIG. 6A

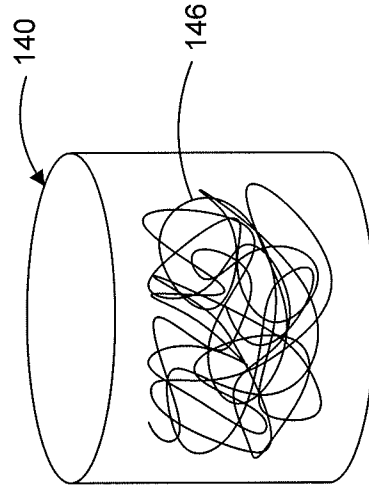

FIG. 6C

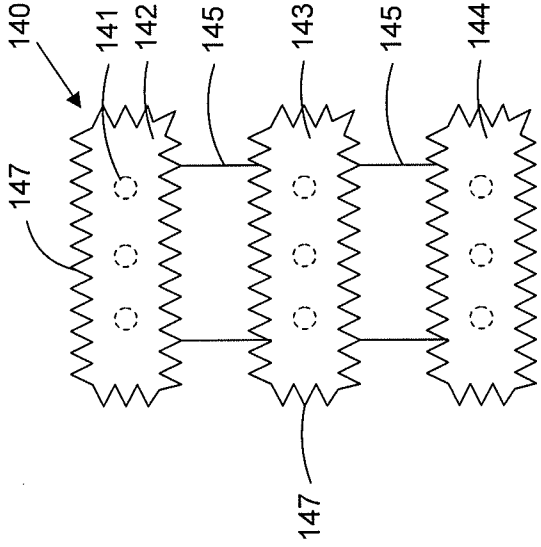

FIG. 7A

FIG. 7B

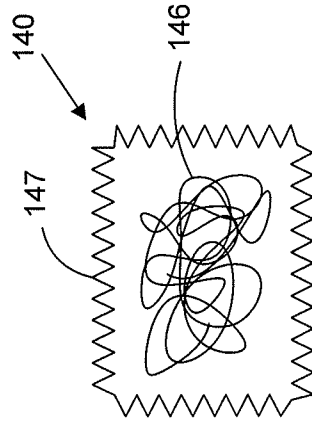

FIG. 7C

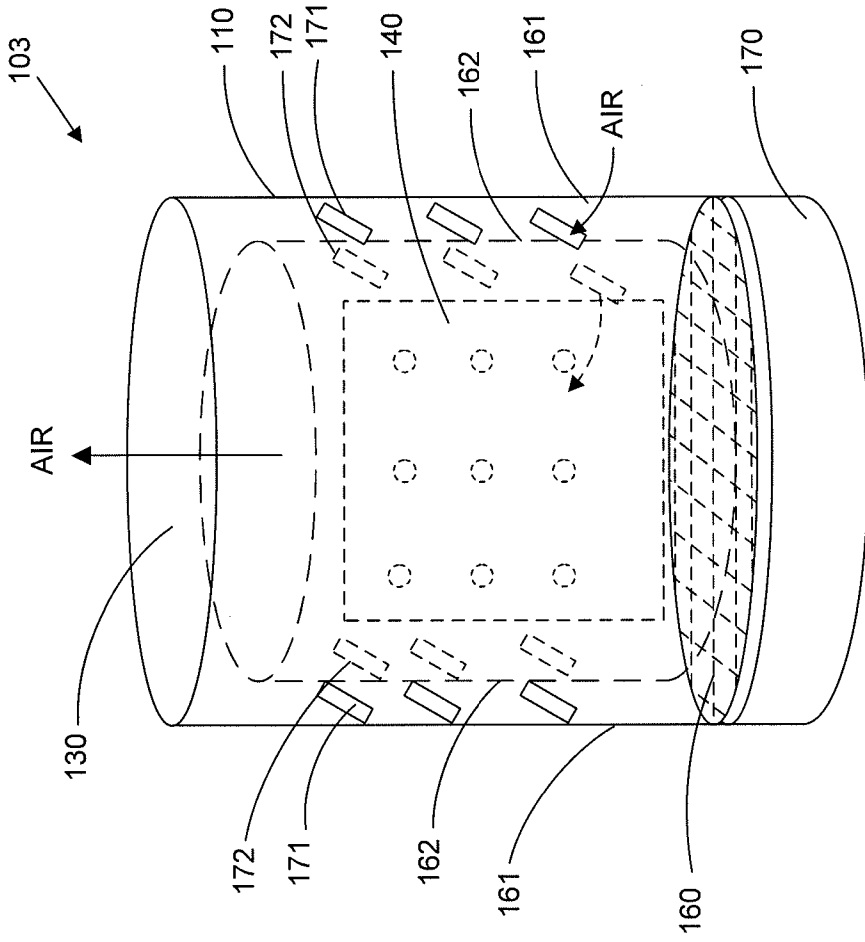

FIG. 8

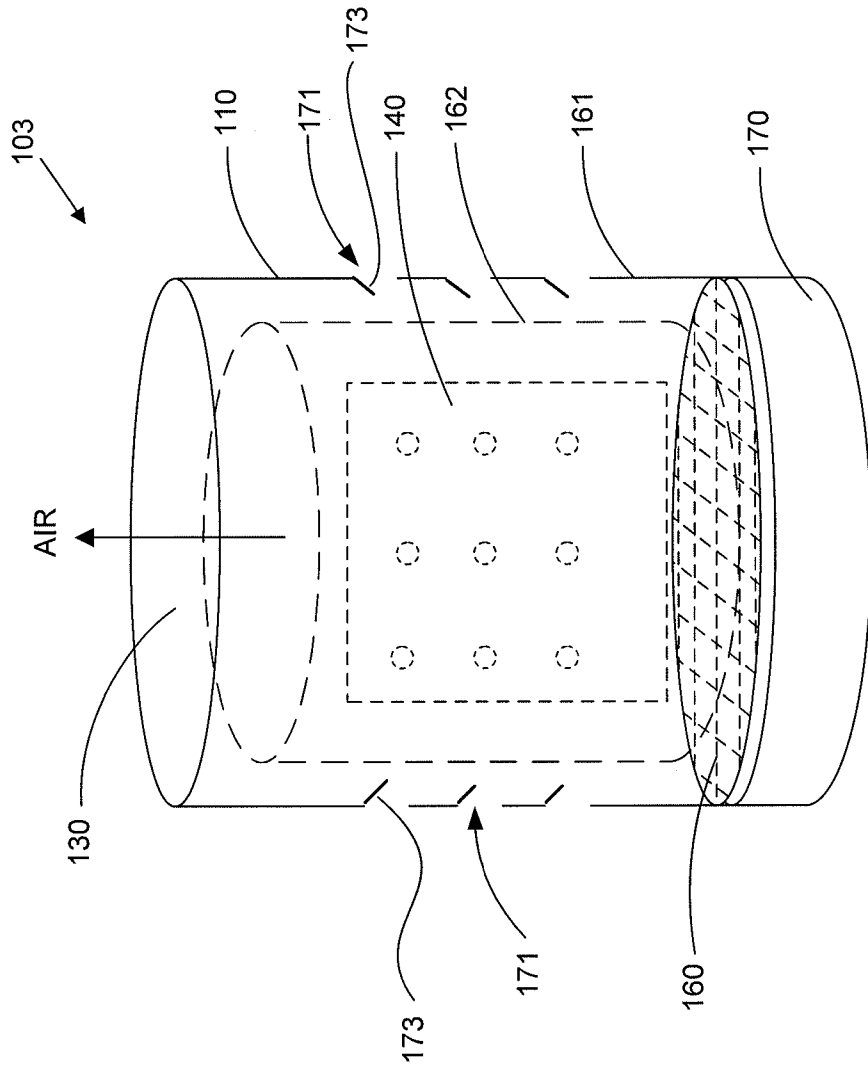

FIG. 9

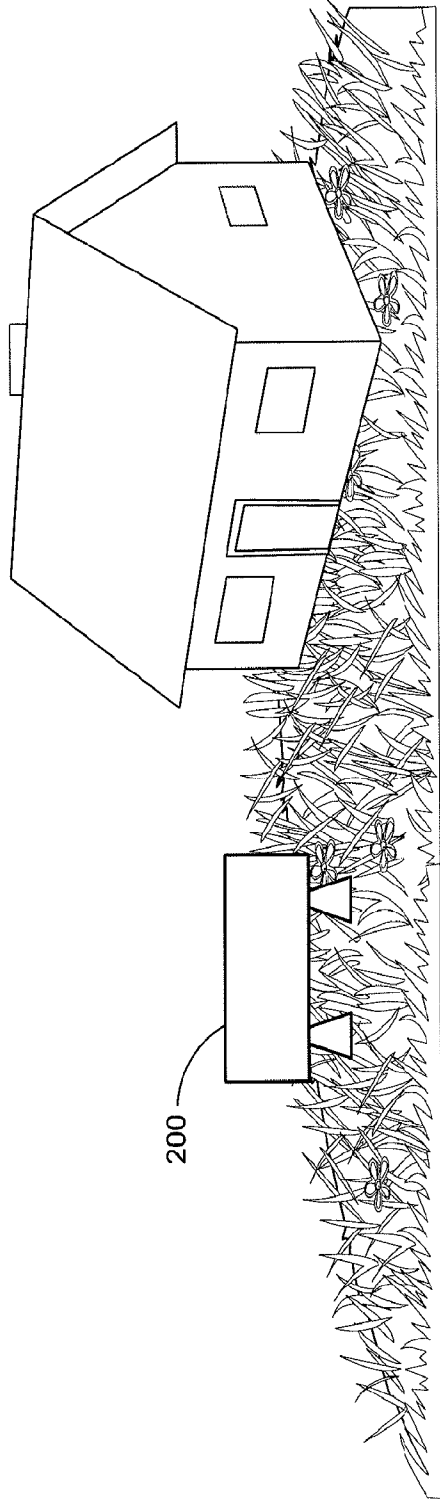
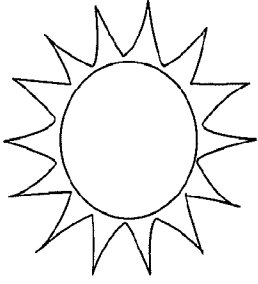

FIG. 10

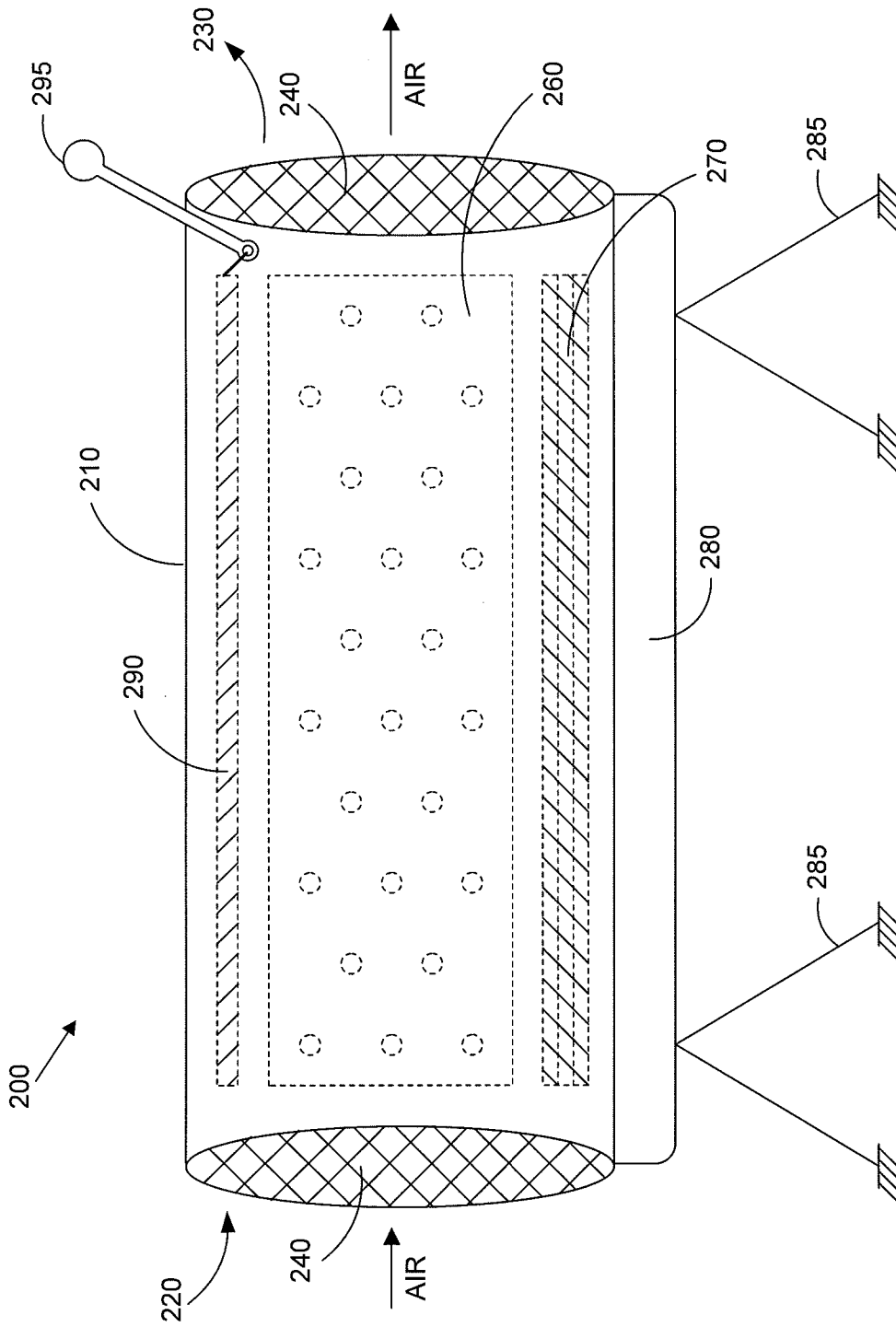

FIG. 11

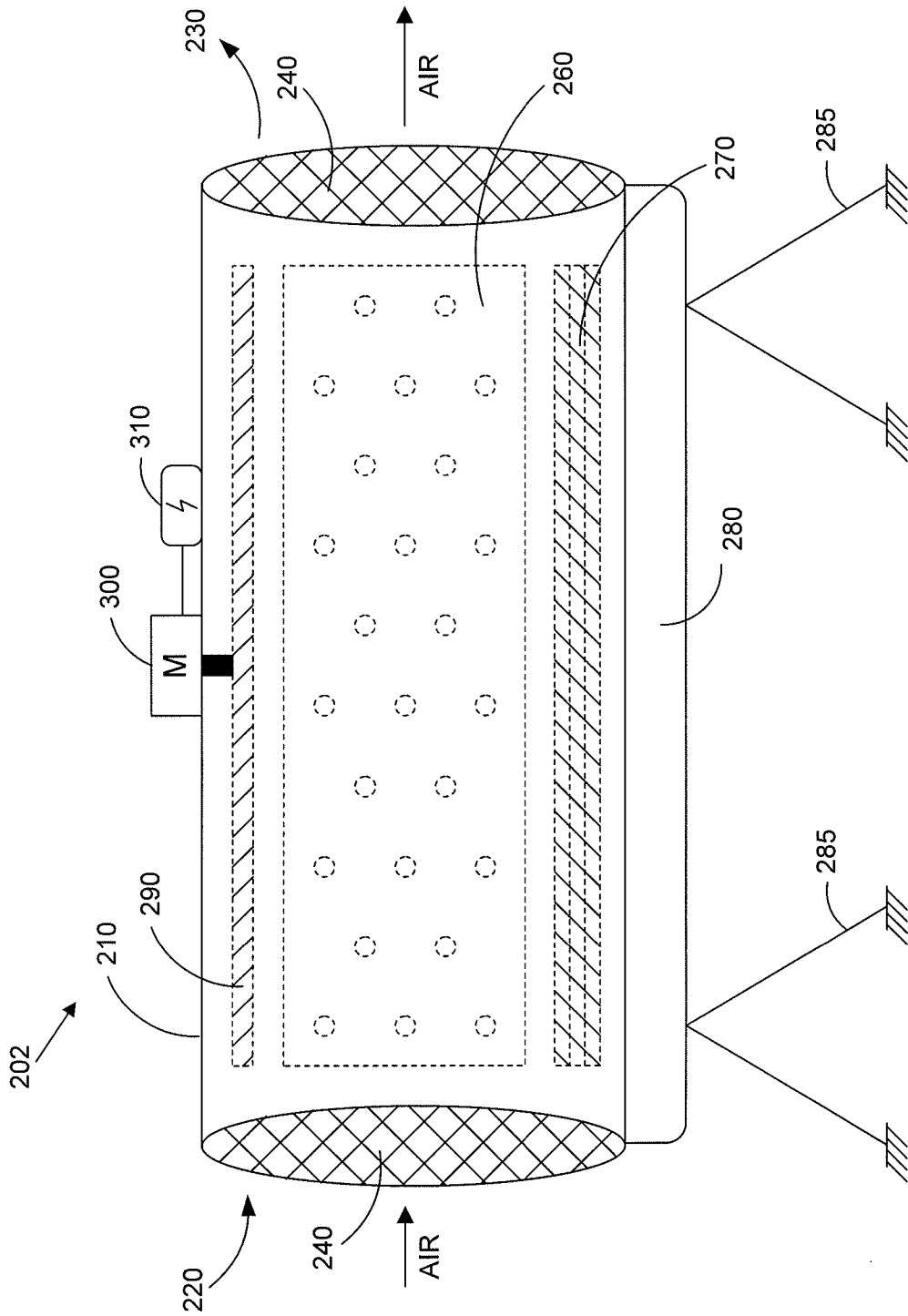

FIG. 12

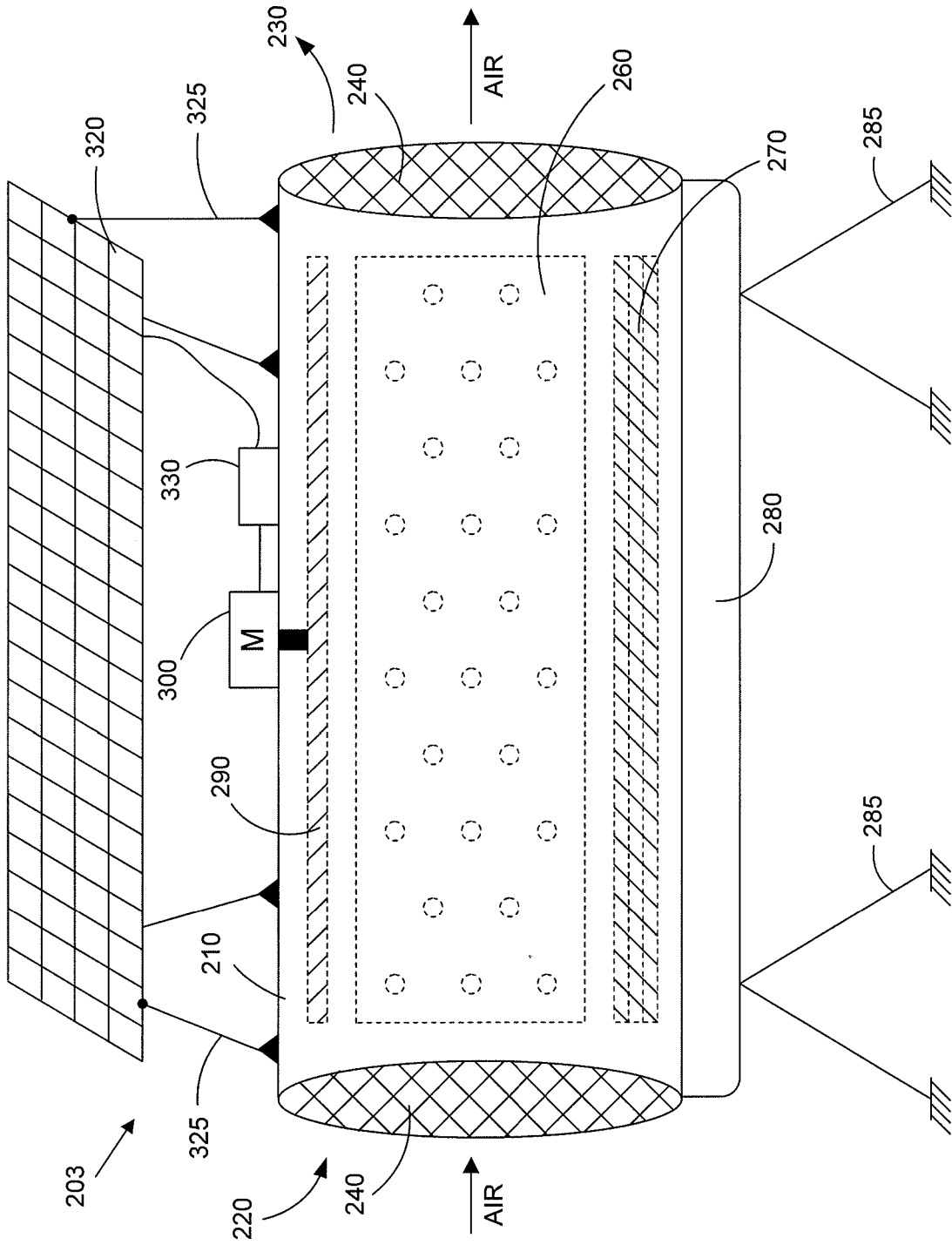

FIG. 13

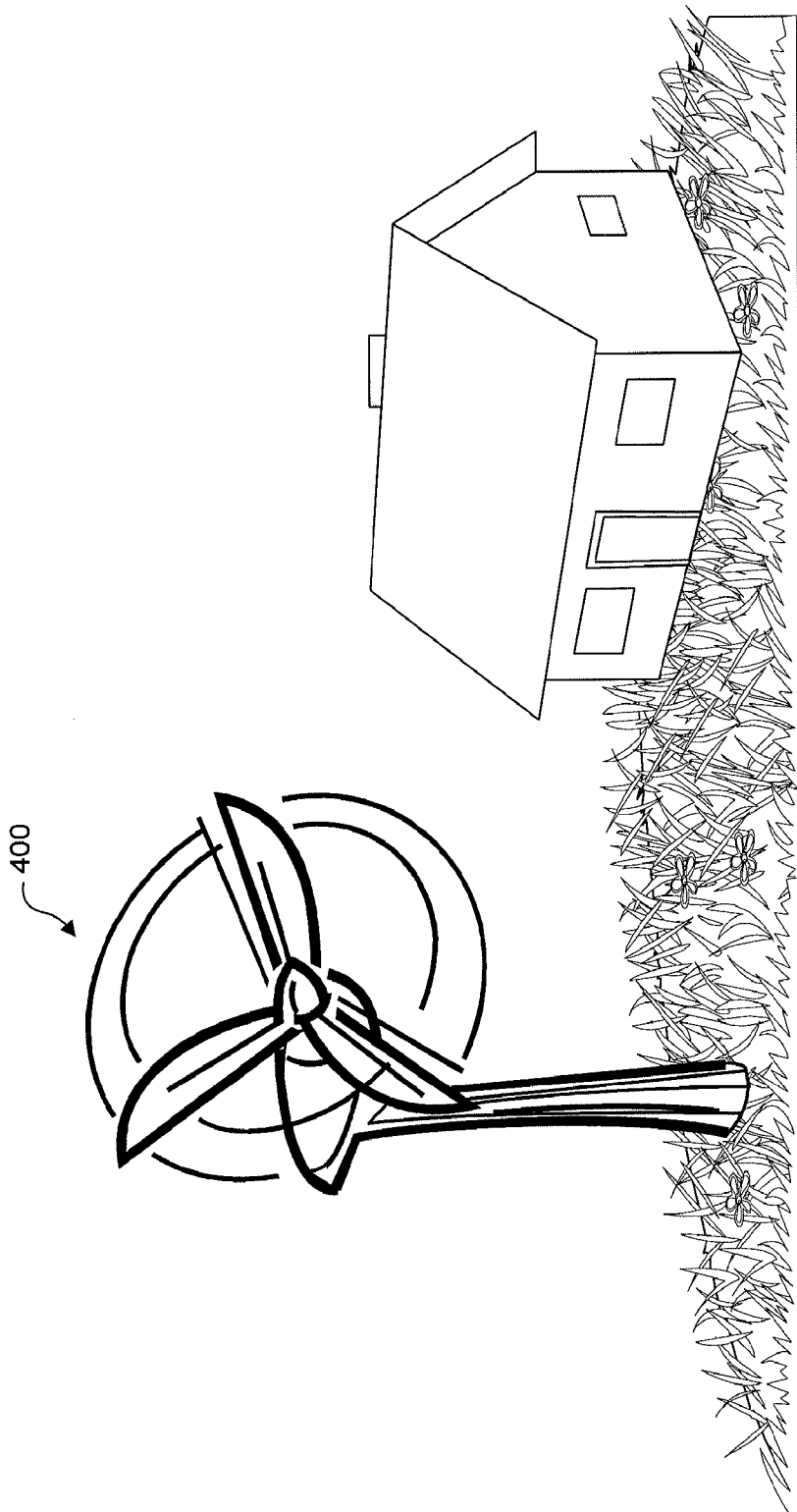

FIG. 14

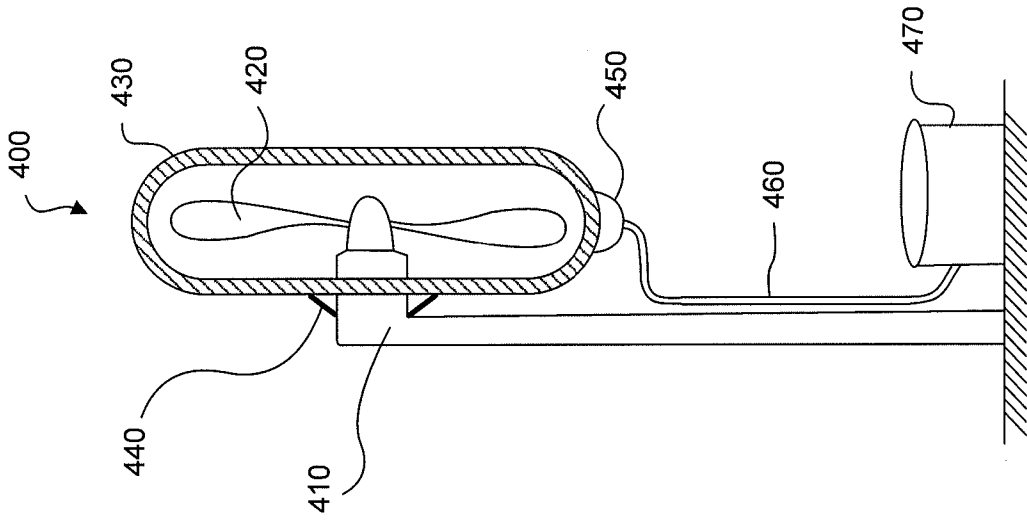

FIG. 15A

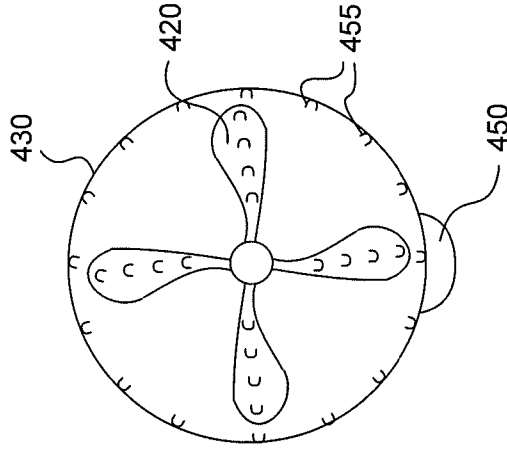

FIG. 15B

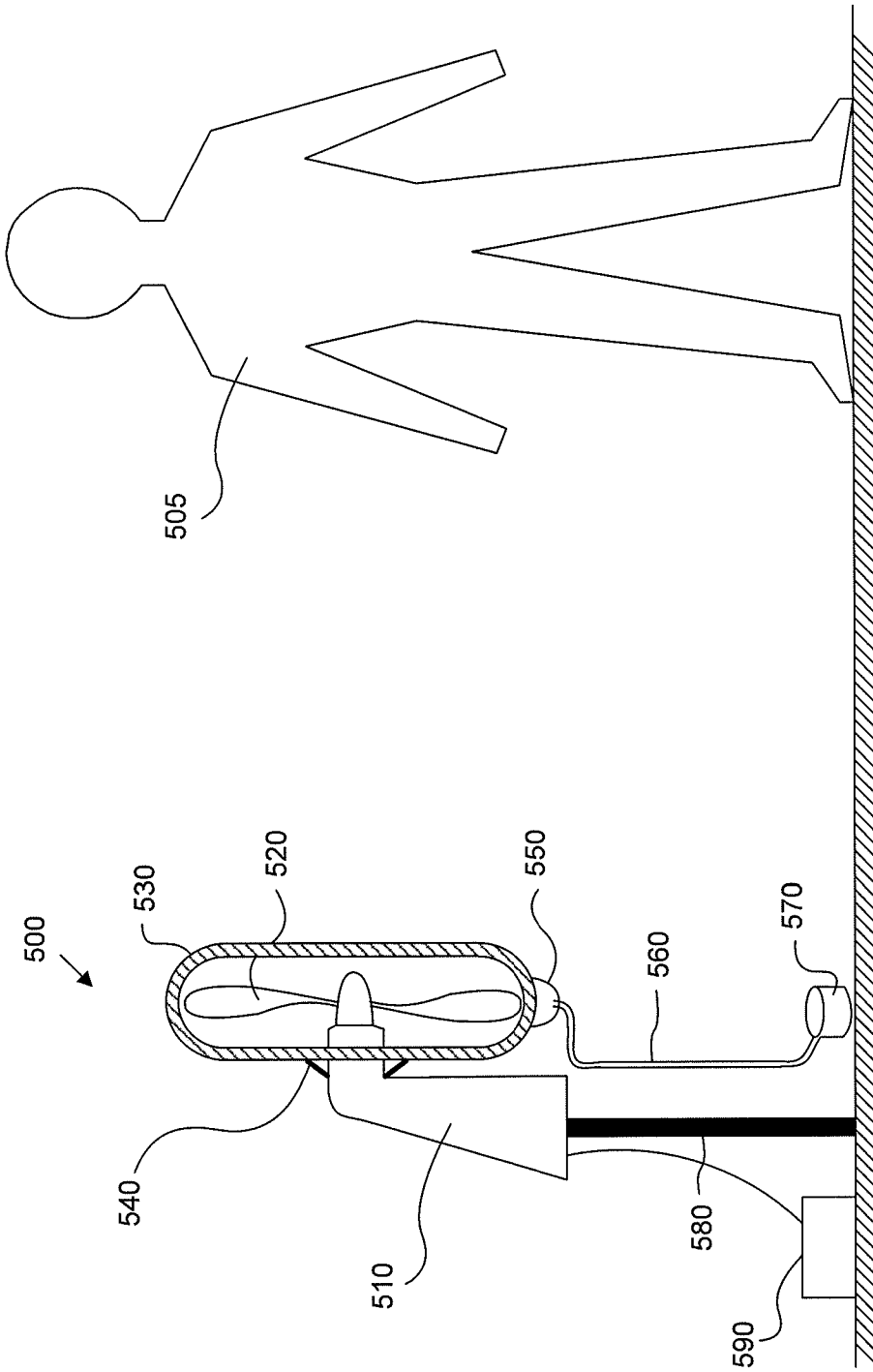

FIG. 16

REFERENCES CITED IN THE DESCRIPTION

This list of references cited by the applicant is for the reader's convenience only. It does not form part of the European patent document. Even though great care has been taken in compiling the references, errors or omissions cannot be excluded and the EPO disclaims all liability in this regard.

Patent documents cited in the description

- WO 0136885 A [0006]

EP 2 675 955 B1

SZTNH_KAO-20170622-0938-
008342/A00CBDDF
2017.06.22**RENDSZEREK VÍZ EXTRAHÁLÁSÁRA LEVEGŐBŐL****Szabadalmi igénypontok**

1. Rendszer (100; 102; 103; 200; 202; 203) víz extrahálására levegőből, ahol az magában foglalja a következőket:
 - egy készülékház (110; 111; 210); és
 - egy szivacsot (140; 260), amely egy belső téren belül van elrendezve, amely a készülékház (110; 111; 210) által van meghatározva, ahol a szivacs tartalmaz egy vizet abszorbeáló/adszorbeáló anyagot a vízgőz abszorbeálására/adszorbeálására egy levegőáramból a belső térben;
 - és egy nyomószerkezetet,**azzal jellemezve, hogy:**
 - a készülékház (110; 111; 210) magában foglal több nyílást (120; 125; 171, 172), hogy legyen lehetővé téve az, hogy a levegőáram bejusson a belső térbe, amely a készülékház által van meghatározva; és
 - azzal, hogy** a nyomószerkezet (150; 290) a szivacs (140; 260) felett van elrendezve és arra a célra van kialakítva, hogy a szivacs legyen összenyomva, hogy a víz legyen kiürítve a szivacsból.
2. Rendszer az 1. igénypont szerint, amely továbbá magában foglalja a következőket:
 - egy nyomószerkezet-meghajtóegységet (155; 295), amely arra a célra van kialakítva, hogy emberi erő legyen használva a nyomószerkezet (150; 290) meghajtására.
3. Rendszer az 1. igénypont szerint, amely továbbá magában foglalja a következőket:
 - egy nyomószerkezet-meghajtóegységet (155; 300), amely arra a célra van kialakítva, hogy egy elektromos energiaforrás (190; 310; 320, 330) legyen használva a nyomószerkezet (150; 290) meghajtására.
4. Rendszer az 1. igénypont szerint, amely továbbá magában foglalja a következőket:
 - egy ventilátort (180), amely a készülékház (110; 111) egy vég-pozíciójában van elrendezve és arra a célra van kialakítva, hogy energia legyen fogadva egy elektromos energiaforrástól (190).
5. Rendszer az 1. igénypont szerint, amely továbbá magában foglalja a következőket:
 - egy vízsűrőt (160; 270), amely a szivacs (140; 260) alatt van elrendezve, hogy legyen szűrve a víz, amely a szivacsból van kiürítve; és
 - egy víztartályt (170; 280), amely a vízsűrő (160; 270) alatt van elrendezve, hogy legyen tárolva a víz, amely a szivacsból (140; 260) van kiürítve és a vízsűrő által van szűrve.
6. Rendszer az 1. igénypont szerint, ahol a készülékházban (111) található több nyílás magában foglal több spirál alakú nyílást (125).
7. Rendszer az 1. igénypont szerint, ahol a nyomószerkezet (150) egy hálós szerkezettel (152) rendelkezik.
8. Rendszer az 1. igénypont szerint, ahol a szivacs (140) egy blokk-szerkezettel (tömb-szerkezettel) rendelkezik.
9. Rendszer az 1. igénypont szerint, ahol a szivacs (140) egy réteges szerkezettel rendelkezik, amely magában foglal több réteget (142, 143, 144).



SZTNH-100053832

EP 2 675 955 B1

10. Rendszer az 1. igénypont szerint, ahol a szivacs (140) magában foglal több szálát (146) a szivacs egy testén belül.
11. Rendszer az 1. igénypont szerint, ahol:
 - a szivacs (140) magában foglal egy bordás, hullámos vagy sávos (barázdás) felületet (147).
12. Rendszer az 1. igénypont szerint, ahol:
 - a készülékház (110; 111) magában foglal egy kétfalú szerkezetet, amely rendelkezik egy belső fallal (162) és egy külső fallal (161),
 - ahol a szivacs (140) egy olyan téren belül van elrendezve, amely a belső fal (162) által van meghatározva; és
 - ahol a belső fal (162) és a külső fal (161) mind (egyenként) magukban foglalnak több nyílást (171, 172).
13. Rendszer a 12. igénypont szerint, ahol:
 - a készülékház (110; 111) magában foglal több peremet (172), amely befelé terjed a belső fal (162) irányában a több nyílástól (171), amely a külső falon (161) található.
14. Rendszer az 1. igénypont szerint, ahol a készülékház (200) rendelkezik két véggel, ahol a két vég közül az egyik egy levegő-bevezetésként (230) szolgál, amely által lehetővé van téve, hogy a levegőáram bejusson a belső térbe, amely a készülékház által van meghatározva, és a két vég közül a másik egy levegő-kivezetésként (230) szolgál, amely által lehetővé van téve, hogy a levegőáram kijusson a készülékházból.
15. Rendszer a 14. igénypont szerint, amely továbbá magában foglalja a következőket:
 - egy fogantyút (295), amely a készülékházra (210) van rögzítve és mechanikusan össze van kapcsolva a nyomószerkezettel (290).
16. Rendszer a 14. igénypont szerint, amely továbbá magában foglalja a következőket:
 - egy motort (300), amely arra a célra van kialakítva, hogy a nyomószerkezet (290) legyen meghajtva;
 - egy akkumulátort (310), amely arra a célra van kialakítva, hogy elektromos energia legyen szolgáltatva a motornak (300).
17. Rendszer a 14. igénypont szerint, amely továbbá magában foglalja a következőket:
 - egy motort (300), amely arra a célra van kialakítva, hogy a nyomószerkezet (290) legyen meghajtva;
 - egy szolár panelt (napelemet) (320), amely arra a célra van kialakítva, hogy a napenergia legyen átalakítva elektromos energiává; és
 - egy energiatároló berendezést (330), amely arra a célra van kialakítva, hogy legyen tárolva az elektromos energia, amely a szolár panel (napelem) (320) által van átalakítva, és hogy elektromos energia legyen szolgáltatva a motornak (300).