

Nov. 28, 1944.

D. H. MONTGOMERY

2,363,741

HEAT TREATING

Filed Feb. 18, 1942

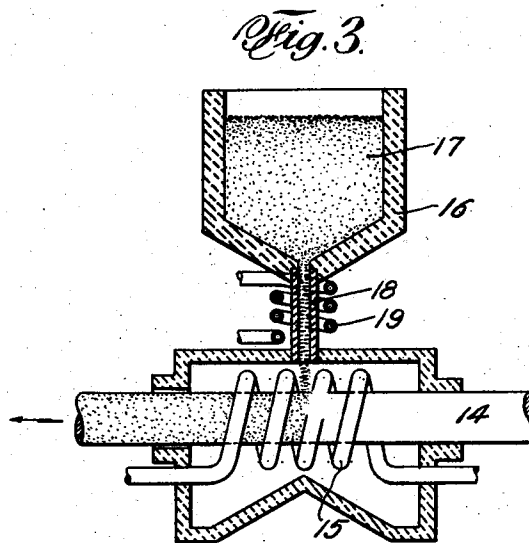
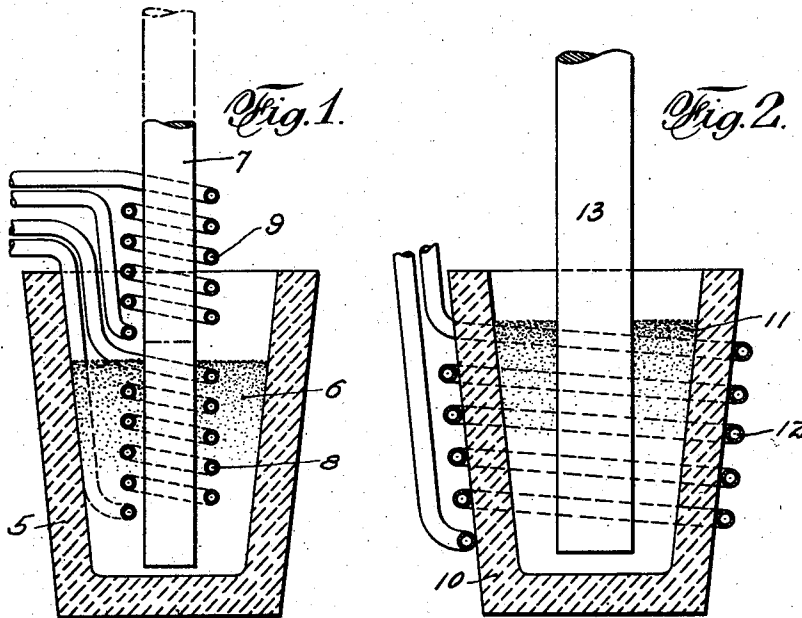

INVENTOR
DONALD H. MONTGOMERY

BY *Mitchell Robert*
ATTORNEYS

UNITED STATES PATENT OFFICE

2,363,741

HEAT TREATING

Donald H. Montgomery, West Hartford, Conn., assignor to The New Britain Machine Company, New Britain, Conn., a corporation of Connecticut

Application February 18, 1942, Serial No. 431,317

1 Claim. (Cl. 148—10)

My invention relates to a method of heat treating metal articles.

It is a general object of the invention to provide an improved method of heat treating metal articles.

A more specific object is to provide an improved method of heat treating metal articles and preventing or minimizing oxidation thereof during and subsequent to heat treatment.

Another object is to provide an improved method of progressively heating an article such as a wire or shaft and protecting the same against oxidation.

Another object is to provide an improved method of heating a metal article to the critical temperature and quenching the same, all while immersed in a quenching liquid.

Other objects and various features of novelty and improvement will be hereinafter pointed out or will become apparent to those skilled in the art.

In the drawing which shows, for illustrative purposes only, and more or less diagrammatically, preferred forms of apparatus

Fig. 1 is a view in vertical section of apparatus for heat treating an article;

Fig. 2 is a similar view of a modified form of apparatus;

Fig. 3 is a vertical sectional view of apparatus for progressively heating an article, such as a shaft or rod, and for coating the article to prevent oxidation thereof.

In the form shown in Fig. 1, I employ a crucible or other container 5 to hold a coating material 6, preferably in the form of a reducing or non-oxidizing salt or other medium, which may be melted and which will serve to coat the metal article immersed therein. I provide means for inductively heating an article, such as a shaft 7, which dips into or is immersed or partially immersed in the coating material 6. As shown in Fig. 1, there may be an induction heating coil 8 within the container and immersed in the coating material 6. The article 7 may pass through the coil and be immersed or partially immersed in the coating material.

When the article 7 is inductively heated by the coil 8, the coating material, for example salts, as disclosed for example in Patent No. 2,002,180 or 2,046,822, will be melted or liquefied by the inductively heated article immersed therein. The induction coil 8 may be a greater or less extent act as a resistance heater to maintain the coating material 6 in a liquid condition. The coating material 6 is preferably of such a nature that it will adhere to the surface of the article 7 and

form a protective coating thereon so as to prevent or minimize oxidation of the article both during heating and during any subsequent operations to be performed thereon.

In the preferred form shown in Fig. 1, I provide further induction means, which may be in the form of a separate induction coil 9 positioned above the coil 8 and through which the article 7 may pass. When the immersed portion of the article is heated by the induction coil 8 and the coating material maintained in a fluid condition, oxidation of the article will be prevented by the immersion of the article in a non-oxidizing coating material. If a higher degree of heating is required, the article may be removed from the coating bath, say, to the dot-dash line position as shown in Fig. 1, where the article with the protective coating adhering thereto may be heated to the desired temperature by the second induction coil 9. When the article has been heated to a point, say, above the critical temperature by the coil 9, the article may be quickly dropped back into the bath 6 and be thereby quenched. In that connection it will, of course, be understood that the bath 6 will be at a temperature sufficiently low to act as a quench when the article has been heated outside of the bath. It will of course be understood that the induction heating means 8—9 will ordinarily be separately controlled so that the heating is done when and where desired.

In the form shown in Fig. 2, the crucible or container 10 holds a coating or bath material 11 which may be of the character heretofore set forth. On the other hand, the bath 11 may consist of various other media, in some cases even water. Induction heating means, such as the coil 12 in the form shown in Fig. 2, is not immersed in the bath 11 but surrounds the container and serves to heat the article 13 when the latter is passed down into the coil and immersed in the bath 11. It will be understood that the bath 11 is of a character to be liquid at a relatively low temperature. It may be used to quench the article 13.

The article 13 when immersed in the bath 11 may, with the proper induction coil, be very rapidly heated to or above the critical temperature even though it be immersed in the bath. When the article is so heated above the critical temperature, the current may be turned off so as to prevent further heating and the article may be then quenched in situ by the bath in which it is immersed.

Instead of immersing the article in a coating

bath, I may employ other means for coating the article so as to prevent oxidation thereof, and in Fig. 3 I have disclosed means for progressively heating and coating an article which may be a shaft, rod, wire, or the like.

In the form shown in Fig. 3, I provide means for progressively moving the article 14 through or past induction heating means, such as an induction coil 15. The article will thereby be heated either to the critical temperature or to such temperature as may be required for any subsequent operations which it is desired to perform on the article. At some point, the article is coated with a coating material so as to prevent oxidation thereof.

I may provide a hopper 16 to carry a supply of coating material 17, which, for example, might be a salt of the che character above referred to. The hopper has an outlet tube or spout 18 opening just above the article 14, and in the form shown positioned so as to drip or flow molten coating material over the article 14 and between the coils of the induction coil 15. As illustrated, I employ a small induction coil 19 for heating the tube 18 or the material therein, or both, so as to liquefy the coating material so it will flow down and thoroughly coat the article 14. When the coil 19 is used to heat relatively small quantities of the coating material in a more or less continuous manner, a relatively steady flow will be maintained even though the bulk of the material 17 may remain in the solid state and fall down into the heating zone and be liquefied only as needed.

The heated article, whether heated in the apparatus of the form shown in Figs. 1, 2 or 3, may be subsequently forged or otherwise acted

on or may be quenched. When a non-oxidizing coating is applied to the article, the article will not be oxidized during any subsequent operations and the material will stay bright and there will be substantially no loss in scale formation if the article be subsequently forged or otherwise treated. The bath material, as stated, may be of a non-oxidizing and even of a reducing character. In most cases, a neutral coating serving simply to exclude air from the surface of the article will suffice and will serve to adequately protect the article against oxidation after the coating is applied. The coating should be such as to adhere quite firmly so as to protect the metal, but should also be readily removable as by dissolving in water or other solvent.

While the invention has been described in considerable detail and preferred method set forth and preferred apparatus more or less diagrammatically shown, it is to be understood that various changes may be made within the scope of the invention as defined in the appended claim.

I claim:

The method of heat treating a metal article, which includes immersing the article in a fusible bath non-oxidizing to the article and capable of wetting the surface thereof, inductively heating the article while so immersed in the bath, removing the article from the bath with part of the material of the bath forming an oxidation preventing coating thereon, then inductively heating the coated article, and thereafter re-immersing the article in the bath to quench the same.

DONALD H. MONTGOMERY.