

(No Model.)

M. L. RITCHIE.
APPARATUS FOR SAWING STONE.

No. 525,283.

Patented Aug. 28, 1894.

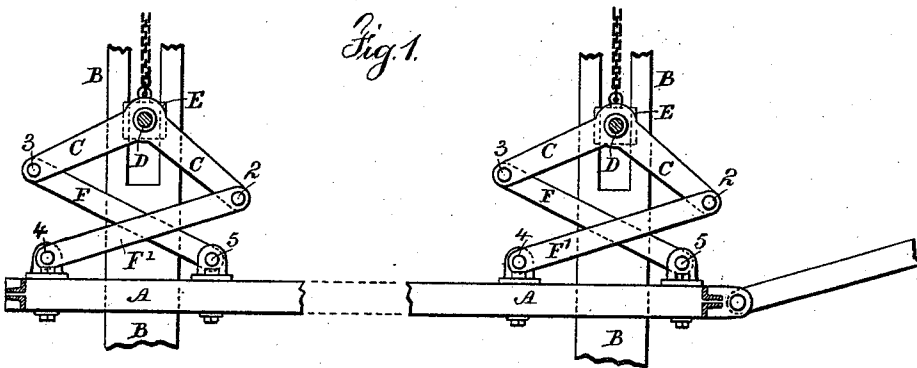
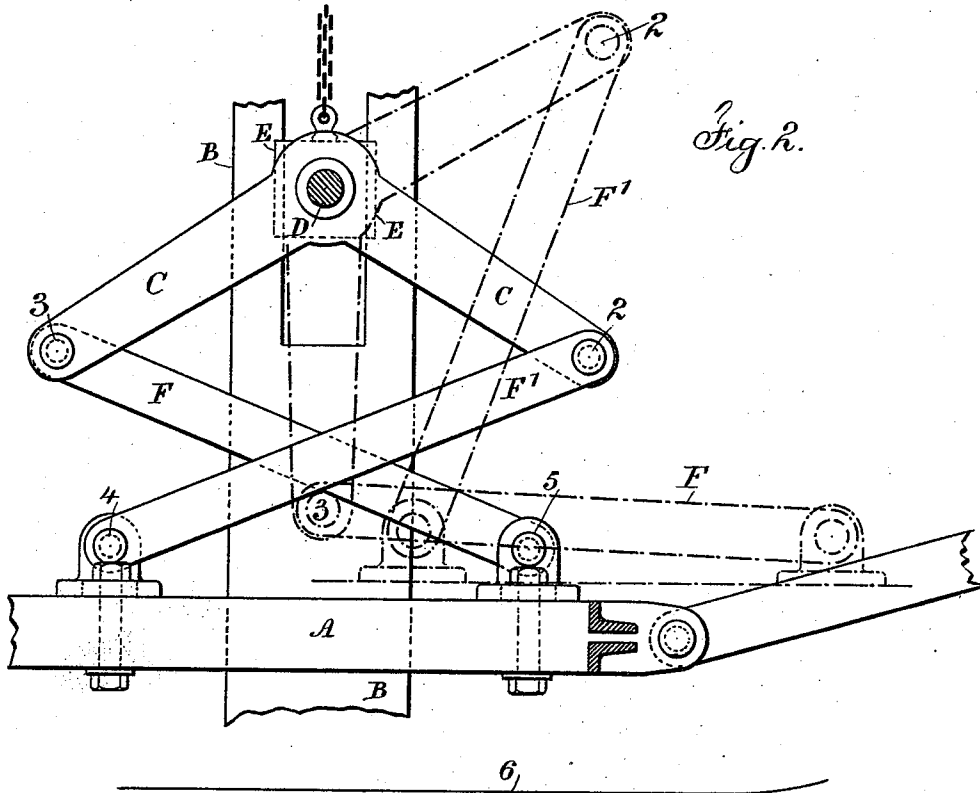

Witnesses
Charles Smith
J. Stair

Inventor
Matthew L. Ritchie
per Lemuel W. Ferrill
Atty.

UNITED STATES PATENT OFFICE.

MATTHEW L. RITCHIE, OF NEW YORK, N. Y., ASSIGNOR TO HIMSELF AND
BROWNE & MAGOWN, OF SAME PLACE.

APPARATUS FOR SAWING STONE.

SPECIFICATION forming part of Letters Patent No. 525,283, dated August 28, 1894.

Application filed May 28, 1894. Serial No. 512,608. (No model.)

To all whom it may concern:

Be it known that I, MATTHEW L. RITCHIE, a citizen of the United States, residing in the city, county, and State of New York, have invented an Improvement in Apparatus for Sawing Stone, of which the following is a specification.

In sawing stone it has heretofore been usual to provide a frame or sash in which straight blades of steel are stretched parallel to each other and at the proper distances apart, and the frame is reciprocated by a crank or otherwise and sand allowed to percolate by the action of water into the saw cuts and pass beneath the saws so that the abrading of the stone is the result of the reciprocation of the saw and the rubbing action of the sand. In machines of this character links have been provided to act near the end of the reciprocation to lift the frame and saws sufficiently for the sand to pass down beneath such saws, and devices have been provided for gradually lowering the gang of saws as the operation progresses.

In my present invention I make use of angular yokes upon rock shafts in combination with link connections crossing each other and extending from the ends of the angular yokes to the saw frame, the lengths of the links being so proportioned to the distance between the pivots upon the angular yokes that a substantially parallel movement is obtained of the saw frame except at the extreme ends of the movements, at which time one set of links that is nearly horizontal acts upon the angular yokes in such a manner that the other set of links lifts the frame and saws bodily, and the extent of the lifting action can be regulated in proportion to the reciprocating movement given to the saw frames and saws. By this means the saws rest with the proper amount of weight upon the stone to act to the best advantage in sawing the same by the action of the sand, and the angular yokes and crossing links are similar to the parallel motion sometimes employed in connection with steam engines, with the exception that the proportions are varied as aforesaid, in order that the lifting motion may be communicated to the frame and saws near the ends of the reciprocations thereof.

In the drawings, Figure 1 is a vertical section illustrative of the present improvement. Fig. 2 represents the parallel motion bars in larger size and indicates the lifting action near one end of the reciprocation.

The saw frame A may be of any desired character; sometimes the same is made with wooden side pieces and metal ends or in some instances the frame is made entirely of metal, and the saws are introduced in the same in any usual manner, but they are not represented in the drawings for greater clearness, and the saw frame with the saws is held between the vertical guide posts B which are of ordinary construction, and the ends of the rock shafts D pass into the boxes E that slide between the angular guide posts, and these boxes and the means for moving the same are of any desired character. In some instances screws are used for raising and lowering these boxes E and in other instances they are suspended by chains passing over pulleys, it being understood that the boxes are raised up sufficiently high to allow for the block of stone being introduced beneath the saws and then the saw frame and saws are lowered until they are in the proper proximity to the block of stone to be reciprocated, and the lowering is performed gradually as the sawing progresses so that the saws rest with the proper weight upon the stone, but the parallel motion bars are able to lift the frame and saws at the end of the movements, as hereinafter indicated.

The angular yokes C are in pairs near the boxes E and upon the rock shafts D, such angular yokes being permanently fastened to the rock shafts so as to move in unison, and to the ends of the angular yokes the links F and F' are pivoted, and these links cross each other, and the lengths of the links F and F' are slightly less than the distance between the pivots 2 and 3 by which the upper ends of such links are connected to the angular yokes, and the pivots 4 and 5 at the lower ends of the links F and F' are connected to the saw frames A, preferably by slotted blocks and bolts, so that the distances between the pivots 4 and 5 can be regulated for obtaining the necessary parallelism in the motion during the principal portion of the stroke.

It will now be understood, especially by reference to Fig. 2 in which the parts are shown by dotted lines in the position that they assume when near one end of the stroke, that the link F being nearly horizontal acts to give motion to the angular yoke C and turn the same with the rock shaft, and that at this time the pivot 3 is almost directly under the rock shaft and is hence moving nearly horizontally, and the pivot 2 is moving almost vertically in relation to the link F', hence the lifting movement given to the saw frame and saws can be varied according to the extent of end motion given to the saw frame and saws by the connecting rod and crank usually employed in reciprocating the parts, and this lift of the saws allows the sand to pass down beneath such saws, and as soon as the reciprocation commences in the other direction, the saw frame and saws are lowered so that the saws rub upon the sand and abrade the stone, and near the end of the movement in the opposite direction the lever F' assumes a horizontal or nearly horizontal position, and the pivot 2 is beneath the rock shaft, and the pivot 3 is moving upwardly in relation to the link F, so that such link F raises the saw frame and saws bodily to allow the sand to pass beneath the same. In Fig. 2 the lift at the end of the movement is illustrated by the line 6 that would be described on an indicator card.

When the parts are in the intermediate positions, as illustrated in Fig. 1, the saw frame and saws are sustained to the desired extent, and the motion of the saw frame and saws is substantially horizontal because the angles which the crossing links assume are similar to those in a parallel motion, the one link swinging downwardly as the other swings upwardly, hence this improvement is better adapted to maintaining the proper condition and operation of the saws and insure more rapid work than the devices heretofore made use of.

I am aware that parallel motions have been

employed in which crossing links are pivoted at their ends, and also that in the sawing of stone single links and pairs of links and rock shafts and arms have been employed in sustaining the saw frame and saws, but the devices to which the links have been pivoted have not been in the form of angular yokes, and hence the parallel movements and the lifting action heretofore described have not been obtained.

As the crank that acts on the connecting rod turns the center the momentum of the saw and frame is expended in actually lifting the frame and saws, as before described, and the weight hanging by the links tends to start the frame in the other direction, hence the movements of the saws and frame are without noise and concussion.

I claim as my invention—

1. The combination with the frame and saws for sawing stone, of cross rock shafts and angular yokes upon such cross rock shafts in pairs, crossing links pivoted to the ends of the angular yokes and pivotal connections from the lower ends of the links to the saw frame, the links being proportioned in length to the distance between the pivots on the angular yokes, so as to produce a lifting action near the ends of the reciprocations of the saw frame, substantially as set forth.

2. The combination with the frame and saws for sawing stone, of cross rock shafts and angular yokes upon such cross rock shafts in pairs, crossing links pivoted to the ends of the angular yokes and pivotal connections from the lower ends of the links to the saw frame, the links being shorter than the distance between the pivots upon the angular yokes, so that one set of links acting upon the angular yokes causes the other set of links to lift the saw frame, substantially as set forth.

Signed by me this 24th day of May, 1894.

M. L. RITCHIE.

Witnesses:

GEO. T. PINCKNEY,

A. M. OLIVER.