



(22) Date de dépôt/Filing Date: 2003/06/06

(41) Mise à la disp. pub./Open to Public Insp.: 2004/12/06

(45) Date de délivrance/Issue Date: 2007/03/27

(51) Cl.Int./Int.Cl. *E05D 11/10* (2006.01)

(72) Inventeur/Inventor:
OCHIAI, MANABU, JP

(73) Propriétaire/Owner:
RIKENKAKI KOGYO KABUSHIKI KAISHA, JP

(74) Agent: SMART & BIGGAR

(54) Titre : CHARNIERE DE PORTE MUNIE D'UNE BUTEE

(54) Title: CHECKER-EQUIPPED DOOR HINGE

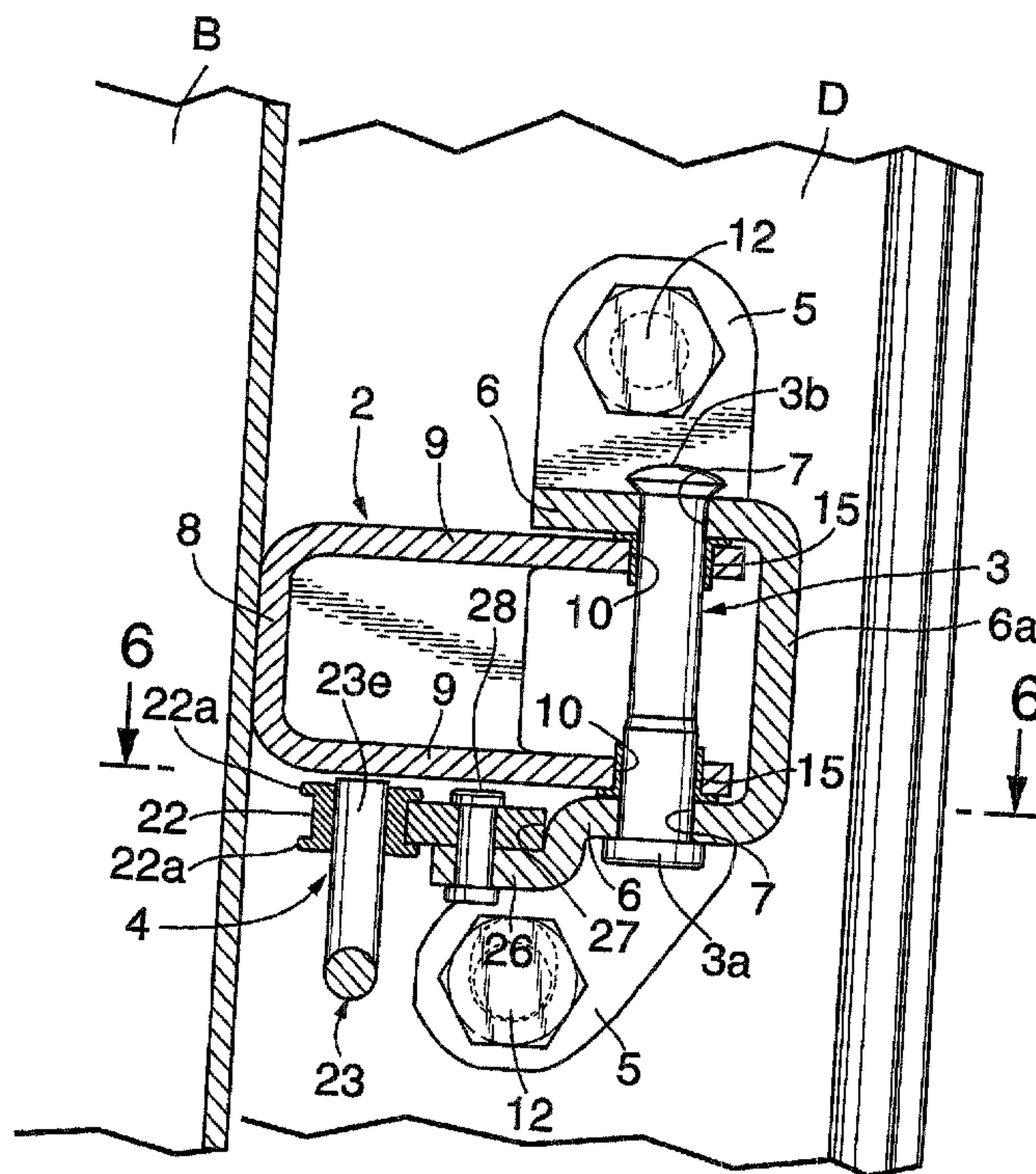

(57) Abrégé/Abstract:

A checker-equipped door hinge includes a checker that is provided between first and second hinge arms and imparts a stepwise limiting resistance to pivoting of the two hinge arms relative to each other. The checker includes a check cam that is formed separately from the first hinge arm and is fixedly attached to the first hinge arm; a roller that can sequentially engage with decent notches of the check cam in response to the pivoting of the two hinge arms relative to each other; and a torsion spring that is mounted in the second hinge arm while supporting the roller with its free end portion, the torsion spring biasing the roller in a direction in which it engages with the detent notches. Thus, a plurality of types of checker-equipped door hinges having various check properties can be provided at low cost by standardizing the hinge arm.

ABSTRACT

A checker-equipped door hinge includes a checker that is provided between first and second hinge arms and imparts a stepwise limiting resistance to pivoting of the two hinge arms relative to each other. The checker includes a check cam that is formed separately from the first hinge arm and is fixedly attached to the first hinge arm; a roller that can sequentially engage with detent notches of the check cam in response to the pivoting of the two hinge arms relative to each other; and a torsion spring that is mounted in the second hinge arm while supporting the roller with its free end portion, the torsion spring biasing the roller in a direction in which it engages with the detent notches. Thus, a plurality of types of checker-equipped door hinges having various check properties can be provided at low cost by standardizing the hinge arm.

CHECKER-EQUIPPED DOOR HINGE

BACKGROUND OF THE INVENTION

Field of the Invention

The present invention relates to a checker-equipped door hinge used in an automobile, etc. and in particular to an improvement in a door hinge that includes a first hinge arm fixedly attached to one of a body and a door, a second hinge arm fixedly attached to the other one of the body and the door, a hinge pin connecting the first and second hinge arms in a relatively pivotable manner, and a checker provided between the first and second hinge arms, the checker imparting a stepwise limiting resistance to pivoting of the two hinge arms relative to each other.

Description of the Related Art

As disclosed in, for example, Japanese Patent Application Laid-open No. 2001-295535, a conventional checker-equipped door hinge has a checker formed from a check cam formed integrally with a first hinge arm, a roller that can sequentially engage with a plurality of detent notches of the check cam in response to pivoting of the first and second hinge arms relative to each other, and a check spring that biases the roller in a direction in which the roller engages with the detent notches.

Since the conventional checker-equipped door hinge has such an arrangement, if a plurality of types of checker-equipped door hinges having various check properties are prepared according to the types of vehicles in which they are mounted, it is necessary to make a plurality of types of first hinge arms together with check cams having various shapes. Therefore, preparation of a plurality of types of checker-equipped door hinges having various check properties requires much expenditure of time and labor, and it is difficult to reduce the cost.

SUMMARY OF THE INVENTION

70488-257

The present invention has been achieved in view of such circumstances, and it is an object of the present invention to provide, with low cost, a plurality of types of checker-equipped door hinges having various check properties
5 by standardizing a hinge arm.

In order to accomplish this object, a first aspect of the present invention provides a checker-equipped door hinge that comprises a first hinge arm fixedly attached to one of a body and a door, a second hinge arm fixedly
10 attached to the other one of the body and the door, the second hinge arm having a first surface facing a first direction and a second surface facing a second direction opposite the first direction, the first and second surfaces of the second hinge arm having mounting notches formed
15 thereon, a hinge pin connecting the first and second hinge arms in a relatively pivotable manner, and a checker that is provided between the first and second hinge arms and imparts a stepwise limiting resistance to pivoting of the two hinge arms relative to each other; wherein the checker is formed
20 from a check cam that is formed separately from the first hinge arm, has a plurality of detent notches, and is fixedly attached to the first hinge arm, an engagement member that can sequentially engage with the plurality of detent notches in response to the pivoting of the first and second hinge
25 arms relative to each other, and a check spring that is mounted within mounting notches formed on the first and second surfaces of the second hinge arm and biases the engagement member in a direction in which the engagement member engages with the detent notches.

30 In accordance with this first aspect, a plurality of types of checker-equipped door hinges having various check properties can be obtained by preparing a plurality of

70488-257

types only of check cams having various outer peripheral shapes because of various positions and numbers of detent notches, and fixedly attaching these check cams to first hinge arms having identical structures. Therefore, because
5 it is only the shape of the small check cam component is changed according to the requirement of the check properties, and because the comparatively large-sized first hinge arm is used in common for door hinges equipped with various types of checkers, it is possible to mass-produce
10 the first

hinge arm, so that the cost of the various types of checker-equipped door hinges can be greatly reduced.

Furthermore, in accordance with a second aspect of the present invention, in addition to the first aspect, there is proposed a checker-equipped door hinge wherein the check spring is a torsion spring that has a free end portion facing the detent notches and biases the free end portion toward the detent notches when mounted in the second hinge arm, and the engagement member is a roller rotatably supported on the free end portion of the torsion spring.

In accordance with this second aspect, since the torsion spring serves also as a support arm for the roller, the structure can be simplified.

Moreover, in accordance with a third aspect of the present invention, in addition to the first or second aspect, there is proposed a checker-equipped door hinge wherein a pair of opposing outer arms are integrally formed with the first hinge arm, inner arms that are inserted between the outer arms and connected thereto via the hinge pin are formed integrally with the second hinge arm, a mounting flange is provided integrally with one of the outer arms via a positioning step, the mounting flange being spaced from the inner arm that is adjacent to said one of the outer arms, and the check cam is engaged with the positioning step and fixedly attached to the mounting flange.

In accordance with this third aspect, it is possible to improve the mounting precision of the check cam, and to improve the appearance by concealing the inner peripheral end of the check cam with the mounting flange.

Furthermore, in accordance with a fourth aspect of the present invention, in addition to any one of the first to third aspects, there is proposed a checker-equipped door hinge wherein the check cam is made of a sintered metal.

In accordance with this fourth aspect, the check cam having a comparatively complicated shape can be molded easily with high precision, and moreover it is

70488-257

possible to impart oil-bearing properties to the check cam as required, thereby preventing noise when the roller rolls.

According to another aspect of the present invention, there is provided a checker-equipped door hinge
5 that comprises a first hinge arm fixedly attached to one of a body and a door, a second hinge arm fixedly attached to the other one of the body and the door, a hinge pin connecting the first and second hinge arms in a relatively pivotable manner, and a checker that is provided between the
10 first and second hinge arms and imparts a stepwise limiting resistance to pivoting of the two hinge arms relative to each other; wherein the checker is formed from a check cam that is formed separately from the first hinge arm, has a plurality of detent notches, and is fixedly attached to the
15 first hinge arm, an engagement member that can sequentially engage with the plurality of detent notches in response to the pivoting of the first and second hinge arms relative to each other, and a check spring that is mounted in the second hinge arm and biases the engagement member in a direction in
20 which the engagement member engages with the detent notches, wherein a pair of opposing outer arms are integrally formed with the first hinge arm, inner arms that are inserted between the outer arms and connected thereto via the hinge pin are formed integrally with the second hinge arm, a
25 mounting flange is provided integrally with one of the outer arms via a positioning step, the mounting flange being spaced from the inner arm that is adjacent to said one of the outer arms, and the check cam is engaged with the positioning step and fixedly attached to the mounting
30 flange.

According to a further aspect of the present invention, there is provided a checker-equipped door hinge

70488-257

that comprises a first hinge arm fixedly attached to one of a body and a door, a second hinge arm fixedly attached to the other one of the body and the door, a hinge pin connecting the first and second hinge arms in a relatively
5 pivotable manner, and a checker that is provided between the first and second hinge arms and imparts a stepwise limiting resistance to pivoting of the two hinge arms relative to each other; wherein the checker is formed from a check cam that is formed separately from the first hinge arm, has a
10 plurality of detent notches, and is fixedly attached to the first hinge arm, an engagement member that can sequentially engage with the plurality of detent notches in response to the pivoting of the first and second hinge arms relative to each other, and a check spring that is mounted in the second
15 hinge arm and biases the engagement member in a direction in which the engagement member engages with the detent notches, wherein the check spring is a torsion spring that has a free end portion facing the detent notches and biases the free end portion toward the detent notches when mounted in the
20 second hinge arm, and the engagement member is a roller rotatably supported on the free end portion of the torsion spring, and wherein a pair of opposing outer arms are integrally formed with the first hinge arm, inner arms that are inserted between the outer arms and connected thereto
25 via the hinge pin are formed integrally with the second hinge arm, a mounting flange is provided integrally with one of the outer arms via a positioning step, the mounting flange being spaced from the inner arm that is adjacent to said one of the outer arms, and the check cam is engaged
30 with the positioning step and fixedly attached to the mounting flange.

The above-mentioned object, other objects, characteristics, and advantages of the present invention

70488-257

will become apparent from an explanation of a preferred embodiment that will be described in detail below by reference to the attached drawings.

BRIEF DESCRIPTION OF THE DRAWINGS

- 5 FIG. 1 is a plan view of an automobile having a checker-equipped door hinge of the present invention;
- FIG. 2 is an enlarged plan view of part 2 in FIG. 1;
- FIG. 3 is a view from arrows 3-3 in FIG. 2;
- 10 FIG. 4 is a view from arrows 4-4 in FIG. 2;
- FIG. 5 is a cross section along line 5-5 in FIG. 2;
- FIG. 6 is a cross section along line 6-6 in FIG. 5;
- 15 FIG. 7 is a view, corresponding to FIG. 2, showing a state in which a door is fully open.

DESCRIPTION OF THE PREFERRED EMBODIMENT

A preferred embodiment of the present invention is explained below by reference to the attached drawings.

- 20 Firstly, in FIG. 1 to FIG. 3, an automobile body B has a door D for opening and closing an entrance thereof, the door D being attached to the body B via a checker-equipped door hinge H of the present invention. The checker-equipped door hinge H is formed from a first hinge
- 25 arm 1 fixedly attached to the door D, a second hinge arm 2 fixedly attached to the body B, a hinge pin 3 with an expanded head 3a for connecting the two hinge arms 1 and 2

70488-257

in a relatively pivotable manner, and a checker 4 provided between the two hinge arms 1 and 2 and imparting a

stepwise limiting resistance to the pivoting of the two hinge arms 1 and 2 relative to each other.

The first hinge arm 1 is formed from a pair of fixed bases 5, a pair of opposing outer arms 6 rising from opposing edges of the two fixed bases 5, and a connecting part 6a integrally connecting together edges on one side of these outer arms 6, the fixed bases 5 being fixedly attached to an end wall of the door D with bolts 12. A pair of coaxially arranged pin holes 7 are bored in the outer ends of the outer arms 6.

The second hinge arm 2 is formed from an oblong fixed base 8 and a pair of opposing inner arms 9 rising from one end part of the fixed base 8, the fixed base 8 being fixedly attached to the body B with bolts 14. The inner arms 9 have pin holes 10 into which bushes 15 are inserted. The bushes 15 are inserted between the outer arms 6 such that these bushes 10 are in line with the pair of pin holes 7. Fitting the hinge pin 3 with the expanded head 3a into the pin holes 7 and the bushes 15 connects the first and second hinge arms 1 and 2 in a relatively pivotable manner. An expanded part 3b is formed at the tip end of the hinge pin 3 by upsetting to prevent it from dropping out.

In the figures, 'O' denotes the direction in which the door D opens and 'C' denotes the direction in which it closes.

As shown in FIG. 2 to FIG. 6, the checker 4 is formed from a check cam 20 riveted to the first hinge arm 1, a torsion spring 23 attached to the second hinge arm 2, and a roller 22 that is supported on a free end portion of the torsion spring 23 and resiliently engages with the check cam 20.

The check cam 20 is molded, separately from the first hinge arm 1, using a sintered metal, has an overall arced plate shape, and has a plurality of detent notches 25a and 25b arranged in the peripheral direction on the outer peripheral surface thereof. A mounting flange 26 is provided, via an arc-shaped positioning step 27, integrally with one of the outer arms 6 of the first hinge arm 1 to which the

check cam 20 is attached, the mounting flange 26 being spaced from the inner arm 9 adjacent to said one of the outer arms 6. The check cam 20 is superimposed on the mounting flange 26 while engaging the inner peripheral surface of the check cam 20 with the positioning step 27, and fixedly attached to the mounting flange 26 with a plurality of rivets 28.

The outer peripheral surface of the check cam 20 projects outward in the radial direction from the outer peripheral surface of the mounting flange 26, and a plurality of detent notches 25a and 25b are arranged thereon in the peripheral direction. In the illustrated example, the two detent notches 25a and 25b are disposed in two locations on the outer peripheral surface of the check cam 20; in an outer end position close to the outside of the door D, and in a middle position. A section of the outer peripheral surface of the check cam 20 between the middle detent notch 25b and an inner end part close to the inside of the door D is formed into an angled surface 29 approaching the hinge pin 3 side in the direction to the inner end part.

Formed integrally on upper and lower edges of the oblong fixed base 8 of the second hinge arm 2 are a pair of ribs 31 projecting from the surface of the fixed base 8 and connected to the two inner arms 9. A semicylindrical bush 34 is fitted into a pair of first semicircular notches 32 provided in middle sections of the ribs 31. A pair of second semicircular notches 33 are provided on the reverse side (surface on the body B side) of an end part of the fixed base 8 on the side opposite to the inner arms 9, the second notches 33 being arranged parallel to the first notches 32. Openings of these second notches 33 are blocked by a mounting surface of the body B, to which the fixed base 8 is fixedly attached.

The torsion spring 23 is formed from a single length of spring wire rod and has a fixed end portion 23a supported in one of the second notches 33, a torsion shaft portion 23c supported in the first notches 32 via the bush 34, a free end portion 23e disposed so as to face the outer peripheral surface of the check cam

20, a U-shaped fixed arm portion 23b providing a connection between the fixed end portion 23a and one end of the torsion shaft portion 23c, and a U-shaped movable arm portion 23d providing a connection between the other end of the torsion shaft portion 23c and the free end portion 23e. Rotatably fitted around the free end portion 23e is a synthetic resin-molded roller 22 that can roll on the outer peripheral surface of the check cam 20.

A set loading is given to the torsion shaft portion 23c in a twisting direction to bias the free end portion 23e toward the outer peripheral surface of the check cam 20. That is, when the torsion spring 23 is in a free state, and the fixed end portion 23a and the torsion shaft portion 23c are supported on one of the second notches 33 and the bush 34, the movable arm portion 23d is raised from the fixed base 8 as shown by a broken line in FIG. 2. In order to bring the roller 22 of the free end portion 23e into contact with the outer peripheral surface of the check cam 20, if the movable arm portion 23d is pivoted toward the fixed base 8, a repulsive force in the twisting direction is generated in the torsion shaft portion 23c, and this repulsive force biases the free end portion 23e toward the outer peripheral surface of the check cam 20.

Since a pair of flanges 22a are formed at opposite ends of the roller 22, and arranged so as to sandwich the check cam 20 from opposite sides thereof, the roller 22 is prevented from dropping off the free end portion 23e.

The operation of this embodiment is now explained.

Opening and closing the door D allows the first and second hinge arms 1 and 2 to pivot relative to each other around the hinge pin 3 and, accompanying this, each time the roller 22 rolls on the outer peripheral surface of the check cam 20 with a set loading of the torsion spring 23 and engages with the detent notches 25a and 25b, the limiting resistance to the pivotal movement of the door D is generated. When the roller 22 is engaged with each of the detent notches 25a and 25b,

releasing the opening/closing force exerted on the door D enables the door D to be held at that position due to the above resistance.

When the door D is being closed, after the roller 22 goes past the middle detent notch 25b, it goes down the angled surface 29 of the check cam 20 with the set loading of the torsion spring 23, thus giving a closing force to the door D.

When assembling the checker-equipped door hinge H, the fixed end portion 23a and the torsion shaft portion 23c of the torsion spring 23 are first respectively engaged with one of the second notches 33 of the second hinge arm 2 and the bush 34 fitted into the first notches 32, the free end portion 23e supporting the roller 22 is pressed toward the fixed base 8 of the second hinge arm 2, and the free end portion 23e is fixed to the second hinge arm 2 by means of an appropriate jig in a state in which a torsional load is exerted on the torsion shaft portion 23c.

The inner arms 9 of the second hinge arm 2 are then inserted between the outer arms 6 of the first hinge arm 1, and both the arms 6 and the arms 9 are connected together with the hinge pin 3. Detaching the jig from the second hinge arm 2 allows the roller 22 to be pressed against the outer peripheral surface of the check arm 20 due to the set loading of the torsion spring 23.

In this way, the torsion spring 23 can be mounted on the second hinge arm 2 by means of an extremely simple structure in which the first and second notches 32 and 33 are provided on opposite surfaces of the fixed base 8 of the second hinge arm 2, and the torsion shaft portion 23c and the fixed end portion 23a of the torsion spring 23 are engaged with the notches 32 and 33, so that a set loading in the twisting direction is exerted on the torsion shaft portion 23c. In particular, since it is extremely easy to machine the opposite surfaces of the fixed base 8 of the second hinge arm 2 to form the first and second notches 32 and 33, and to engage the torsion shaft portion 23c and the fixed end portion 23a with the first and second notches 32 and 33, the workability and the assemblability are very good, thus contributing to a reduction in the cost.

Moreover, by fixedly attaching the fixed base 8 to the body B, the openings of the second notches 33, with one of which the fixed end portion 23a of the torsion spring 23 is engaged, are blocked by the body B, and it is therefore possible to prevent the fixed end portion 23a from falling out of the second notches 33 without employing any special blocking member, thereby further simplifying the structure.

Furthermore, since the check cam 20 is formed separately from the first hinge arm 1, a plurality of types of checker-equipped door hinges H having various check properties can be obtained by preparing a plurality of types of the check cams 20 having various peripheral shapes because of the positions and number of the detent notches 25a and 25b and fixedly attaching these check cams 20 to the first hinge arms 1 having identical structures. Therefore, because it is only the shape of the small check cam component is changed according to the requirement of the check properties, and because the comparatively large-sized first hinge arm is used in common for door hinges equipped with various types of checkers, it is possible to mass-produce the first hinge arm, so that the cost of the various types of checker-equipped door hinges can be greatly reduced.

Moreover, since the check cam 20 and the first hinge arm 1 are made separately from each other, it is possible to use materials according to their respective functions. In particular, since the check cam 20 is molded using a sintered metal, its comparatively complicated shape can be molded easily with high precision and, moreover, it is possible to impart oil-bearing properties to the check cam 20, thereby preventing noise when the roller 22 rolls.

Furthermore, since the mounting flange 26 is provided integrally with one of the outer arms 6 of the first hinge arm 1 via the positioning step 27, the mounting flange being spaced from the inner arm 9, of the second hinge arm 2, that is adjacent to said one of the outer arms 6, and the check cam 20 is engaged with the positioning step 27 and riveted to the mounting flange 26, it is possible to improve the mounting precision of the check cam 20, and to improve the appearance by

concealing the inner peripheral end of the check cam 20 with the mounting flange 26.

Moreover, since the roller 22 is rotatably fitted around the free end portion 23e of the torsion spring 23 and supported thereby, the torsion spring 23 serves also as a support arm for the roller 22, thereby contributing to a simplification of the structure.

The present invention is not limited by the above-mentioned embodiment and can be modified in a variety of ways without departing from the spirit and scope thereof. For example, the first hinge arm 1 and the second hinge arm 2 can be fixedly attached to the door D and the body B respectively. The check cam 20 may be fixed by welding to the mounting flange 26. Moreover, the number and the positions of the detent notches 25a and 25b formed in the check cam 20 can be freely selected.

70488-257

CLAIMS:

1. A checker-equipped door hinge that comprises a first hinge arm fixedly attached to one of a body and a door, a second hinge arm fixedly attached to the other one
5 of the body and the door, the second hinge arm having a first surface facing a first direction and a second surface facing a second direction opposite the first direction, the first and second surfaces of the second hinge arm having mounting notches formed thereon, a hinge pin connecting the
10 first and second hinge arms in a relatively pivotable manner, and a checker that is provided between the first and second hinge arms and imparts a stepwise limiting resistance to pivoting of the two hinge arms relative to each other;

wherein the checker is formed from a check cam
15 that is formed separately from the first hinge arm, has a plurality of detent notches, and is fixedly attached to the first hinge arm, an engagement member that can sequentially engage with the plurality of detent notches in response to the pivoting of the first and second hinge arms relative to
20 each other, and a check spring that is mounted within mounting notches formed on the first and second surfaces of the second hinge arm and biases the engagement member in a direction in which the engagement member engages with the detent notches.

25 2. The checker-equipped door hinge according to claim 1, wherein the check spring is a torsion spring that has a free end portion facing the detent notches and biases the free end portion toward the detent notches when mounted in the second hinge arm, and the engagement member is a
30 roller rotatably supported on the free end portion of the torsion spring.

70488-257

3. The checker-equipped door hinge according to claim 2, wherein the check cam is made of a sintered metal.

4. The checker-equipped door hinge according to claim 2, wherein a pair of opposing outer arms are
5 integrally formed with the first hinge arm, inner arms that are inserted between the outer arms and connected thereto via the hinge pin are formed integrally with the second hinge arm, a mounting flange is provided integrally with one of the outer arms via a positioning step, the mounting
10 flange being spaced from the inner arm that is adjacent to said one of the outer arms, and the check cam is engaged with the positioning step and fixedly attached to the mounting flange.

5. The checker-equipped door hinge according to
15 claim 4, wherein the check cam is made of a sintered metal.

6. The checker-equipped door hinge according to claim 1, wherein a pair of opposing outer arms are integrally formed with the first hinge arm, inner arms that are inserted between the outer arms and connected thereto
20 via the hinge pin are formed integrally with the second hinge arm, a mounting flange is provided integrally with one of the outer arms via a positioning step, the mounting flange being spaced from the inner arm that is adjacent to said one of the outer arms, and the check cam is engaged
25 with the positioning step and fixedly attached to the mounting flange.

7. The checker-equipped door hinge according to claim 6, wherein the check cam is made of a sintered metal.

8. The checker-equipped door hinge according to
30 claim 1, wherein the check cam is made of a sintered metal.

70488-257

9. A checker-equipped door hinge that comprises a first hinge arm fixedly attached to one of a body and a door, a second hinge arm fixedly attached to the other one of the body and the door, a hinge pin connecting the first
5 and second hinge arms in a relatively pivotable manner, and a checker that is provided between the first and second hinge arms and imparts a stepwise limiting resistance to pivoting of the two hinge arms relative to each other;

wherein the checker is formed from a check cam
10 that is formed separately from the first hinge arm, has a plurality of detent notches, and is fixedly attached to the first hinge arm, an engagement member that can sequentially engage with the plurality of detent notches in response to the pivoting of the first and second hinge arms relative to
15 each other, and a check spring that is mounted in the second hinge arm and biases the engagement member in a direction in which the engagement member engages with the detent notches,

wherein a pair of opposing outer arms are integrally formed with the first hinge arm, inner arms that
20 are inserted between the outer arms and connected thereto via the hinge pin are formed integrally with the second hinge arm, a mounting flange is provided integrally with one of the outer arms via a positioning step, the mounting flange being spaced from the inner arm that is adjacent to
25 said one of the outer arms, and the check cam is engaged with the positioning step and fixedly attached to the mounting flange.

10. The checker-equipped door hinge according to claim 9, wherein the check cam is made of a sintered metal.

30 11. A checker-equipped door hinge that comprises a first hinge arm fixedly attached to one of a body and a

70488-257

door, a second hinge arm fixedly attached to the other one of the body and the door, a hinge pin connecting the first and second hinge arms in a relatively pivotable manner, and a checker that is provided between the first and second
5 hinge arms and imparts a stepwise limiting resistance to pivoting of the two hinge arms relative to each other;

wherein the checker is formed from a check cam that is formed separately from the first hinge arm, has a plurality of detent notches, and is fixedly attached to the
10 first hinge arm, an engagement member that can sequentially engage with the plurality of detent notches in response to the pivoting of the first and second hinge arms relative to each other, and a check spring that is mounted in the second hinge arm and biases the engagement member in a direction in
15 which the engagement member engages with the detent notches,

wherein the check spring is a torsion spring that has a free end portion facing the detent notches and biases the free end portion toward the detent notches when mounted in the second hinge arm, and the engagement member is a
20 roller rotatably supported on the free end portion of the torsion spring, and

wherein a pair of opposing outer arms are integrally formed with the first hinge arm, inner arms that are inserted between the outer arms and connected thereto
25 via the hinge pin are formed integrally with the second hinge arm, a mounting flange is provided integrally with one of the outer arms via a positioning step, the mounting flange being spaced from the inner arm that is adjacent to said one of the outer arms, and the check cam is engaged
30 with the positioning step and fixedly attached to the mounting flange.

70488-257

12. The checker-equipped door hinge according to claim 11, wherein the check cam is made of a sintered metal.

SMART & BIGGAR
OTTAWA, CANADA

PATENT AGENTS

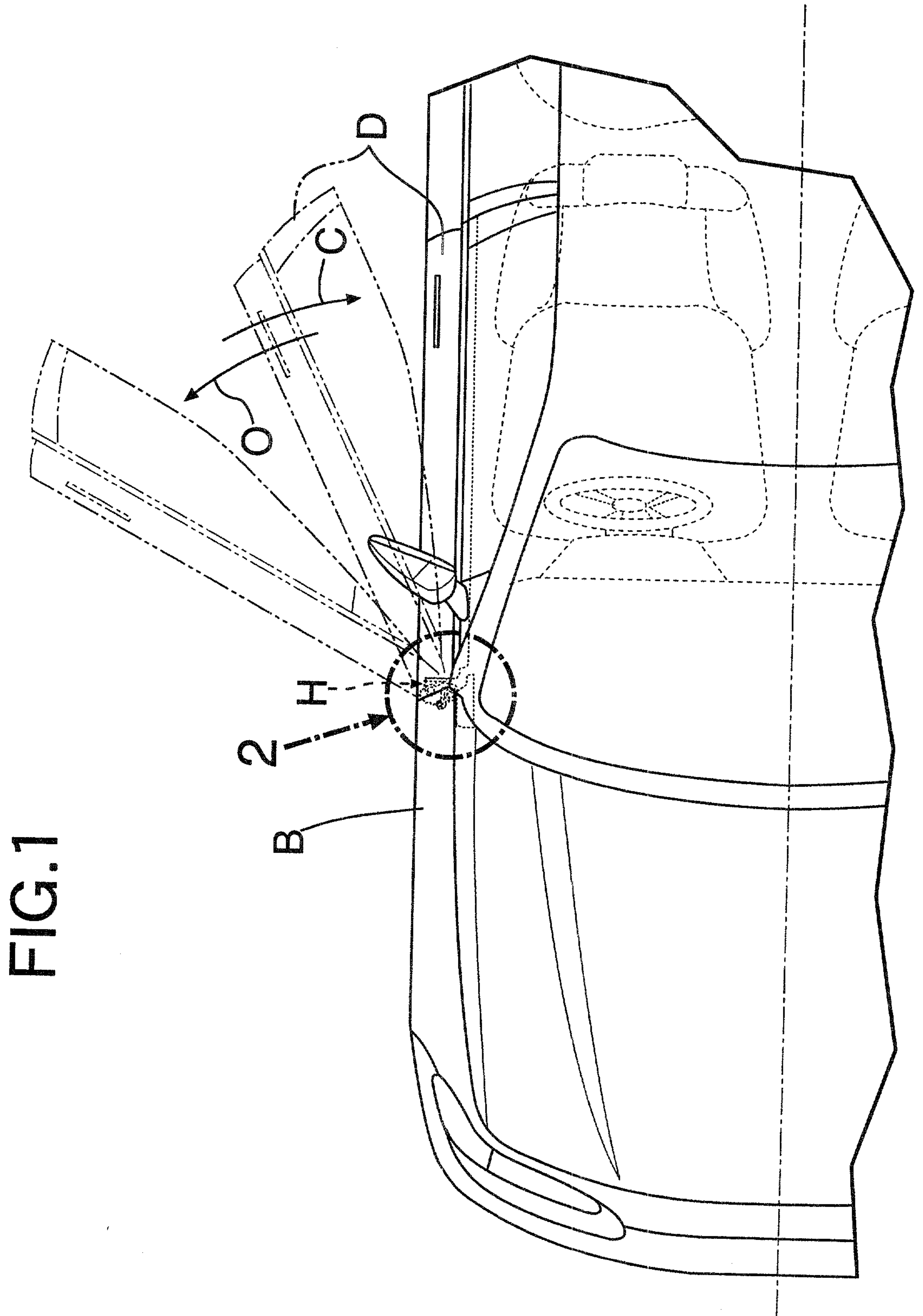
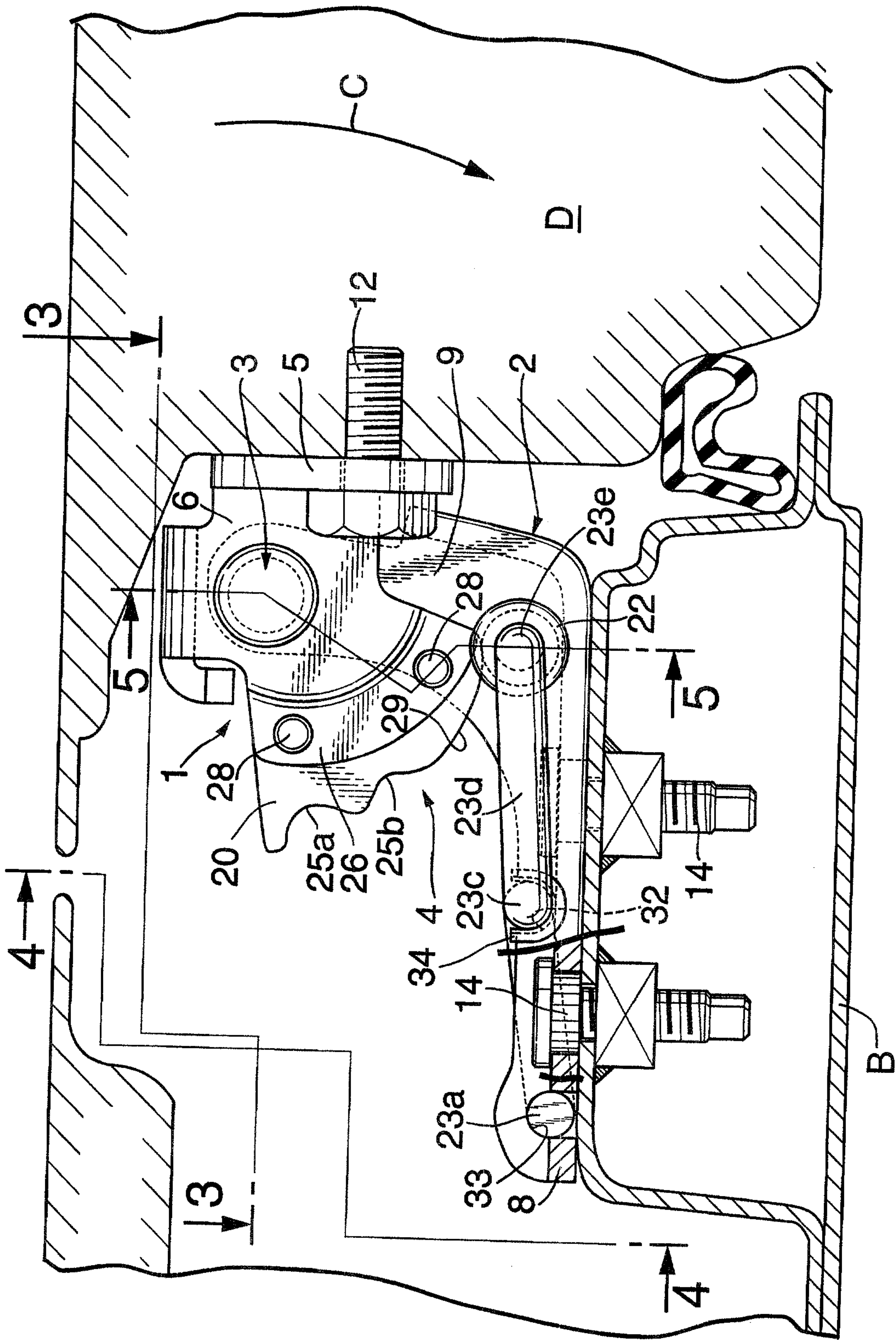

FIG.1

FIG.2



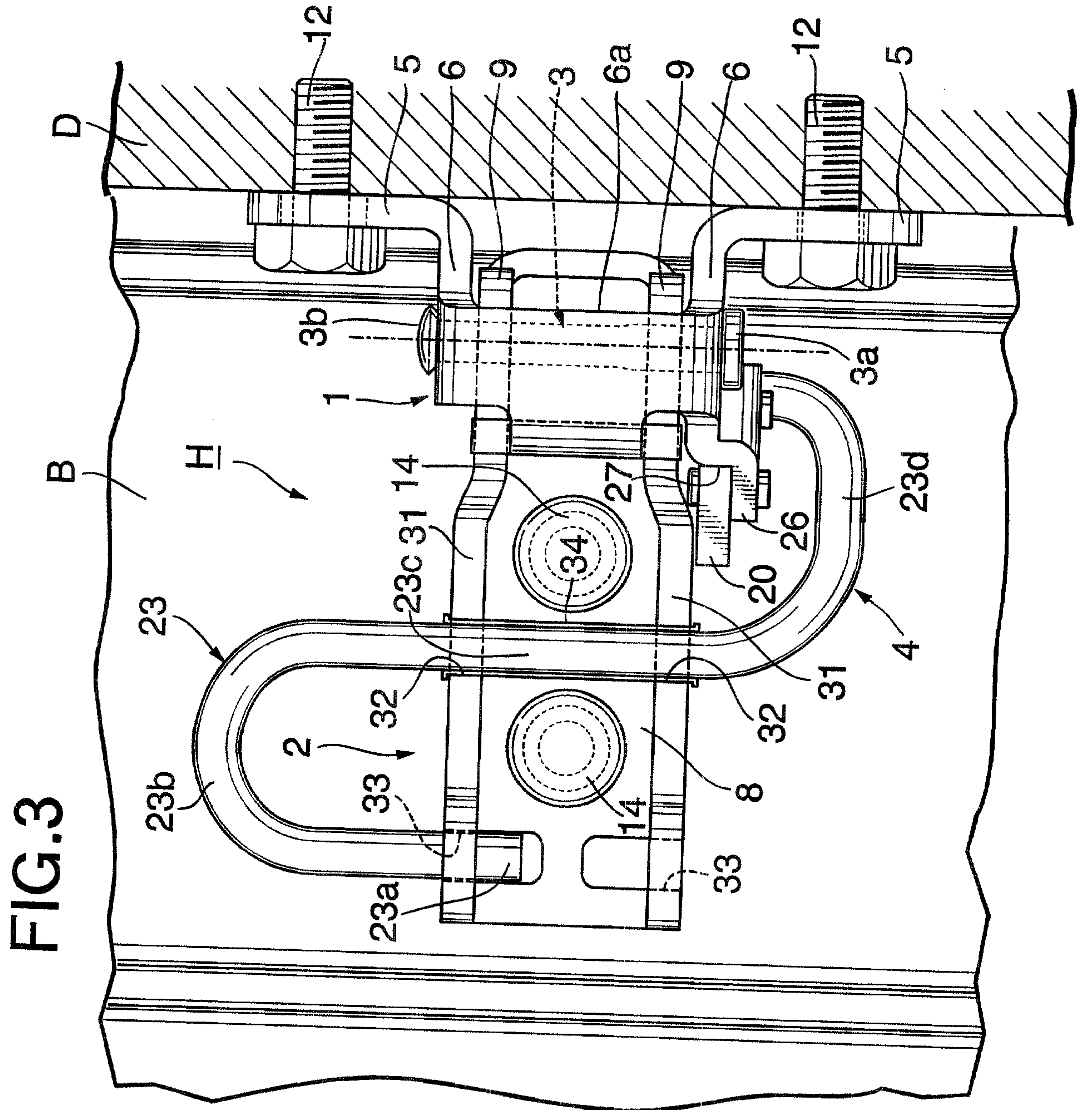

FIG.4

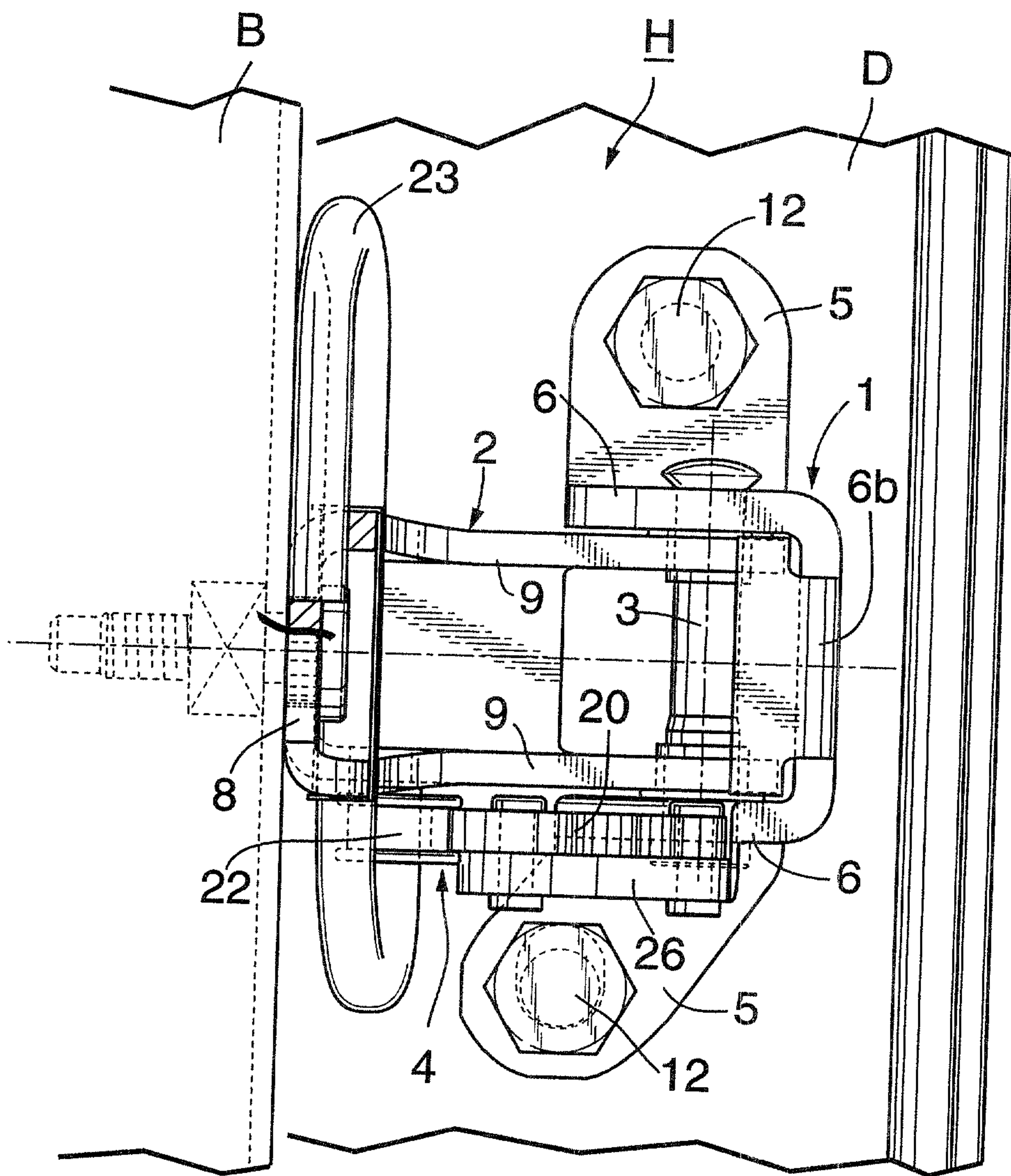

FIG.5

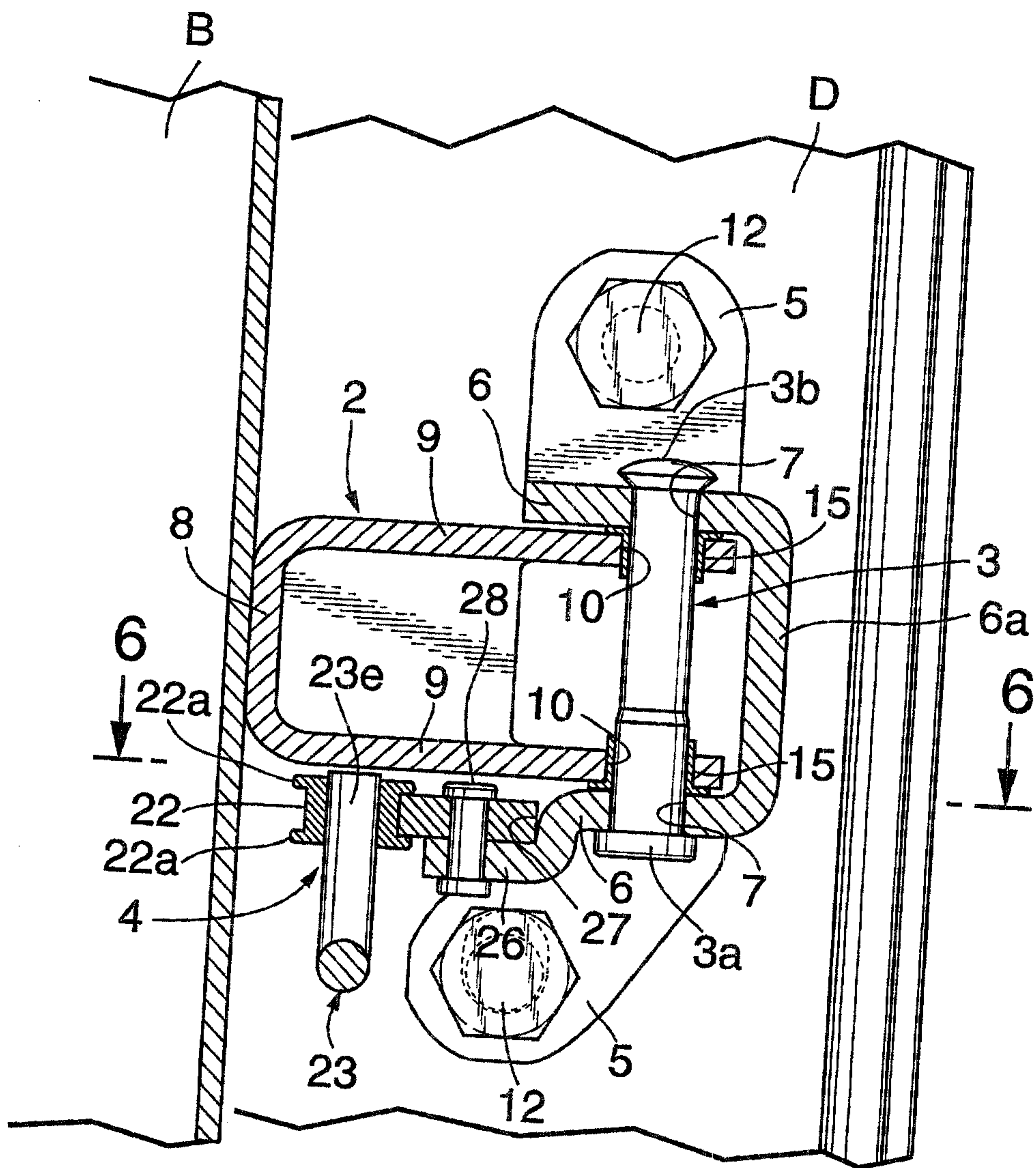

FIG.6

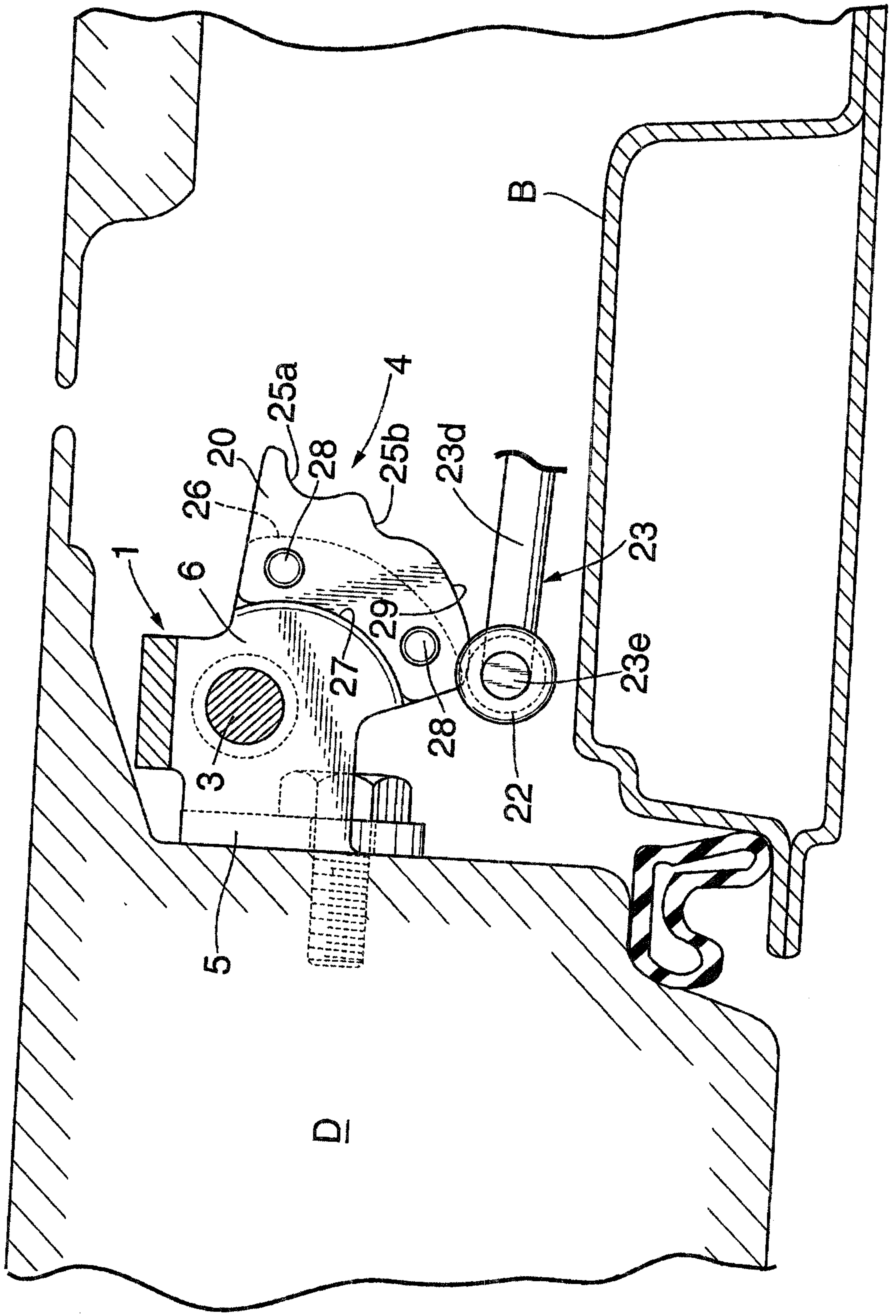

FIG.7

