

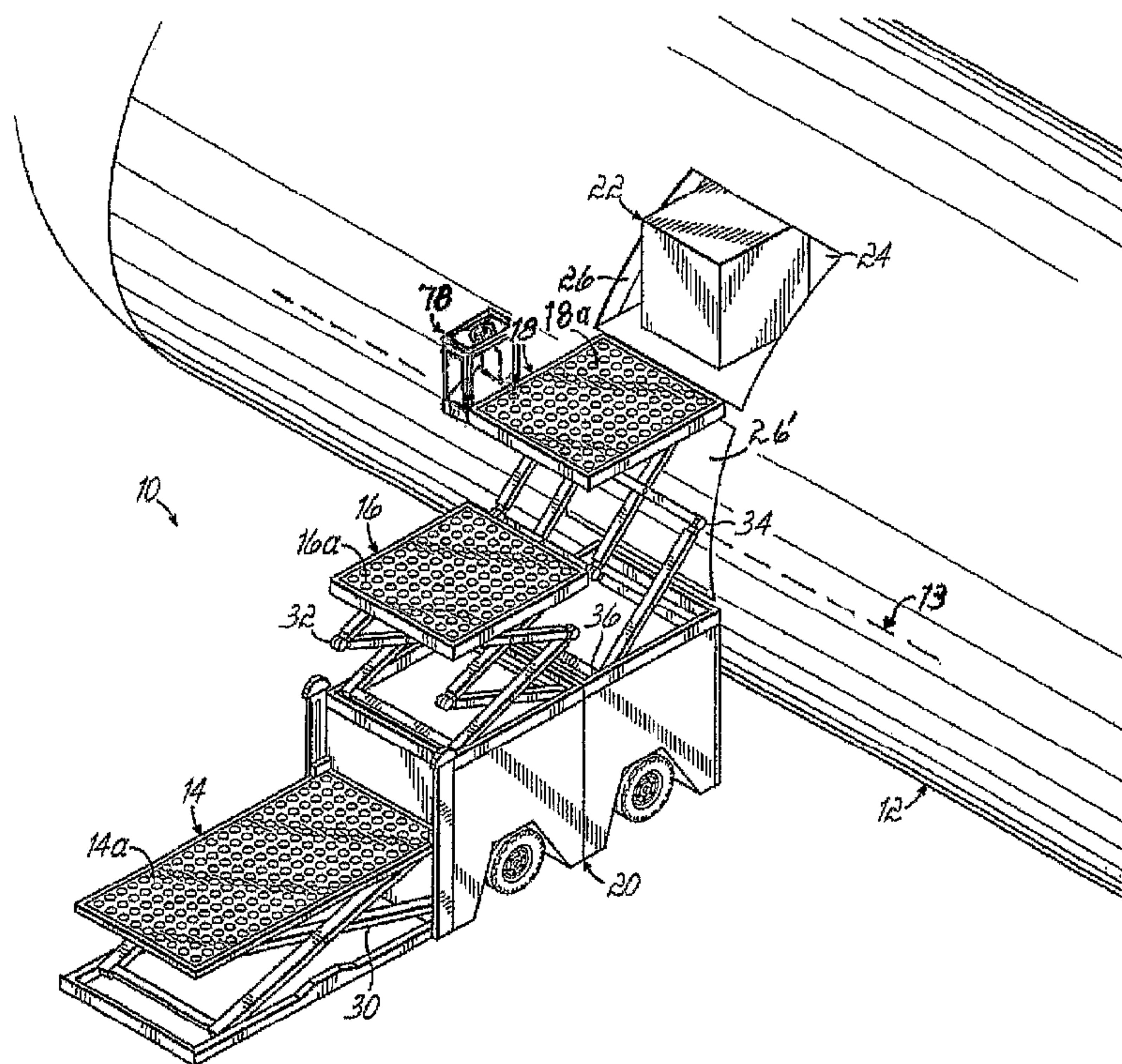

(86) Date de dépôt PCT/PCT Filing Date: 2005/01/07
 (87) Date publication PCT/PCT Publication Date: 2005/08/04
 (85) Entrée phase nationale/National Entry: 2006/06/30
 (86) N° demande PCT/PCT Application No.: US 2005/000396
 (87) N° publication PCT/PCT Publication No.: 2005/070060
 (30) Priorité/Priority: 2004/01/08 (US10/753,781)

(51) Cl.Int./Int.Cl. *B60P 1/02* (2006.01)
 (71) Demandeur/Applicant:
FMC TECHNOLOGIES, INC., US
 (72) Inventeurs/Inventors:
GRUZDEVA, ZINA, US;
GOU, JUAN FRANCISCO, US
 (74) Agent: MACRAE & CO.

(54) Titre : CHARGEUR DE FRET AERIEN A PLATE-FORMES MULTIPLES
 (54) Title: MULTIPLE PLATFORM AIRCRAFT CARGO LOADER



(57) Abrégé/Abstract:

An aircraft cargo loader (10) includes a first generally horizontal platform structure (14, 14', 40, 50, 60) adjustable in height between ground level and a first elevated position. The loader (10) includes a second generally horizontal platform structure (16, 16', 42, 52, 62) positioned adjacent to the first generally horizontal platform structure (14, 14', 40, 50, 60) and adjustable in height relative to the first platform structure (14, 14', 40, 50, 60). A third generally horizontal platform structure (18, 18', 44, 54, 64) is positioned adjacent to the second generally horizontal platform structure (16, 16', 42, 52, 62) and is adjustable in height relative to the first (14, 40) and second generally horizontal platform structures (16, 16', 42, 52, 62). The aircraft cargo loader (10) may include additional platform structures (66, 70), and one or more may be carried by a vehicle (20), and may be completely controllable from a single operator station (78).

(12) INTERNATIONAL APPLICATION PUBLISHED UNDER THE PATENT COOPERATION TREATY (PCT)

(19) World Intellectual Property
Organization
International Bureau



(43) International Publication Date
4 August 2005 (04.08.2005)

PCT

(10) International Publication Number
WO 2005/070060 A3

- (51) International Patent Classification⁷: **B60P 1/02**
- (21) International Application Number:
PCT/US2005/000396
- (22) International Filing Date: 7 January 2005 (07.01.2005)
- (25) Filing Language: English
- (26) Publication Language: English
- (30) Priority Data:
10/753,781 8 January 2004 (08.01.2004) US
- (71) Applicant (for all designated States except US): **FMC TECHNOLOGIES, INC.** [US/US]; 200 East Randolph Drive, Chicago, IL 60601 (US).
- (72) Inventors; and
- (75) Inventors/Applicants (for US only): **GRUZDEVA, Zina** [US/US]; 12021 Pine Court, Leesburg, FL 34788 (US). **GOU, Juan, Francisco** [ES/US]; 4406 Middlebrook Road, Orlando, FL 32811 (US).
- (74) Agent: **MODERSON, Janine, A.**; Pauley Petersen & Erickson, 2800 West Higgins Road, Suite 365, Hoffman Estates, IL 60195 (US).
- (81) Designated States (unless otherwise indicated, for every kind of national protection available): AE, AG, AL, AM, AT, AU, AZ, BA, BB, BG, BR, BW, BY, BZ, CA, CH, CN, CO, CR, CU, CZ, DE, DK, DM, DZ, EC, EE, EG, ES, FI, GB, GD, GE, GH, GM, HR, HU, ID, IL, IN, IS, JP, KE, KG, KP, KR, KZ, LC, LK, LR, LS, LT, LU, LV, MA, MD, MG, MK, MN, MW, MX, MZ, NA, NI, NO, NZ, OM, PG, PH, PL, PT, RO, RU, SC, SD, SE, SG, SK, SL, SM, SY, TJ, TM, TN, TR, TT, TZ, UA, UG, US, UZ, VC, VN, YU, ZA, ZM, ZW.
- (84) Designated States (unless otherwise indicated, for every kind of regional protection available): ARIPO (BW, GH, GM, KE, LS, MW, MZ, NA, SD, SL, SZ, TZ, UG, ZM, ZW), Eurasian (AM, AZ, BY, KG, KZ, MD, RU, TJ, TM), European (AT, BE, BG, CH, CY, CZ, DE, DK, EE, ES, FI, FR, GB, GR, HU, IE, IS, IT, LT, LU, MC, NL, PL, PT, RO, SE, SI, SK, TR), OAPI (BF, BJ, CF, CG, CI, CM, GA, GN, GQ, GW, ML, MR, NE, SN, TD, TG).
- Declarations under Rule 4.17:**
- as to applicant's entitlement to apply for and be granted a patent (Rule 4.17(ii)) for all designations
 - as to the applicant's entitlement to claim the priority of the earlier application (Rule 4.17(iii)) for all designations

[Continued on next page]

(54) Title: MULTIPLE PLATFORM AIRCRAFT CARGO LOADER

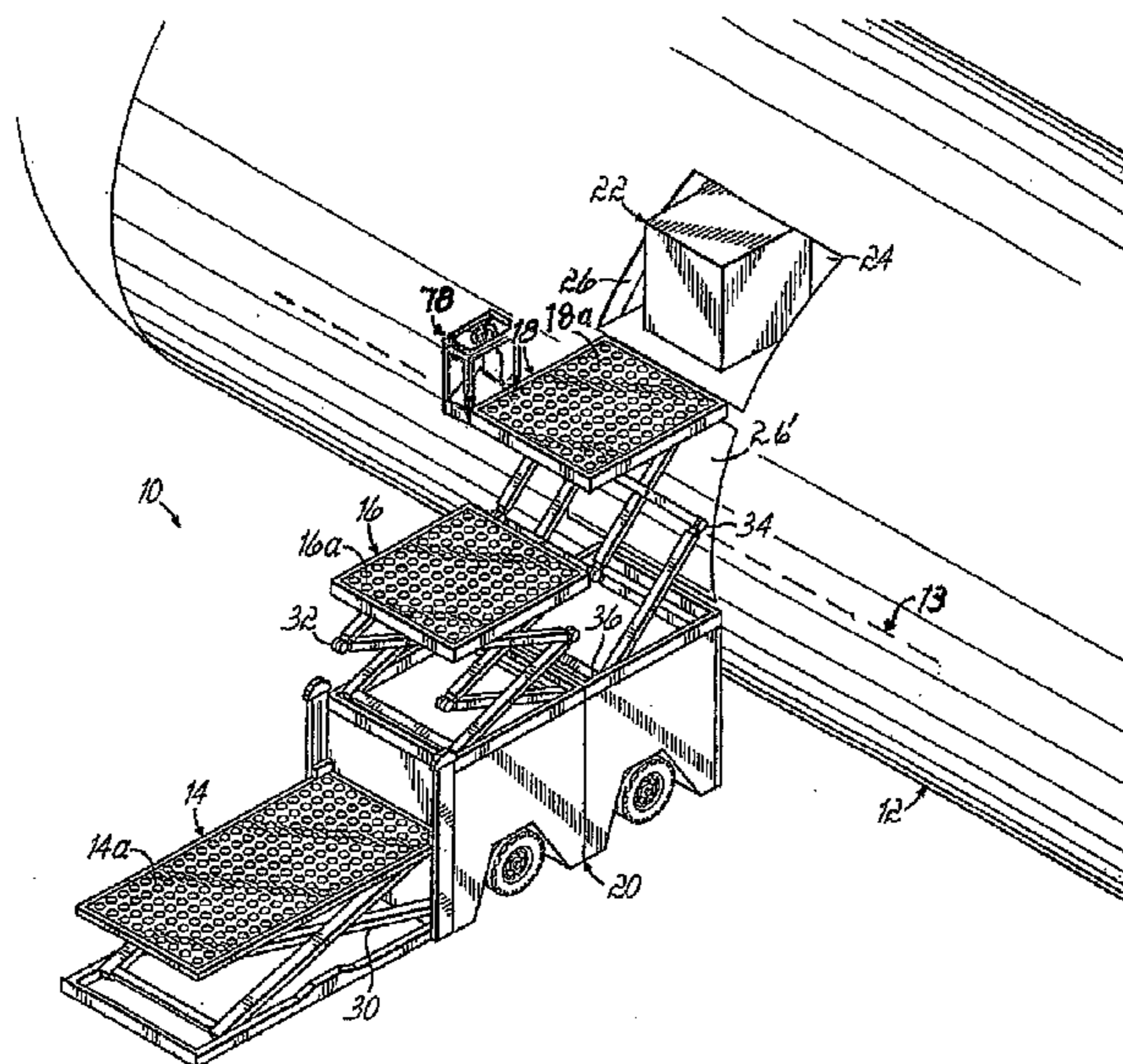

(57) Abstract: An aircraft cargo loader (10) includes a first generally horizontal platform structure (14, 14', 40, 50, 60) adjustable in height between ground level and a first elevated position. The loader (10) includes a second generally horizontal platform structure (16, 16', 42, 52, 62) positioned adjacent to the first generally horizontal platform structure (14, 14', 40, 50, 60) and adjustable in height relative to the first platform structure (14, 14', 40, 50, 60). A third generally horizontal platform structure (18, 18', 44, 54, 64) is positioned adjacent to the second generally horizontal platform structure (16, 16', 42, 52, 62) and is adjustable in height relative to the first (14, 40) and second generally horizontal platform structures (16, 16', 42, 52, 62). The aircraft cargo loader (10) may include additional platform structures (66, 70), and one or more may be carried by a vehicle (20), and may be completely controllable from a single operator station (78).

WO 2005/070060 A3

WO 2005/070060 A3



Published:

- *with international search report*
- *before the expiration of the time limit for amending the claims and to be republished in the event of receipt of amendments*

For two-letter codes and other abbreviations, refer to the "Guidance Notes on Codes and Abbreviations" appearing at the beginning of each regular issue of the PCT Gazette.

(88) Date of publication of the international search report:

1 December 2005

IN THE UNITED STATES RECEIVING OFFICE

TITLE OF THE INVENTION

Multiple Platform Aircraft Cargo Loader

5 CROSS-REFERENCE TO RELATED APPLICATIONS

This application claims the benefit of U.S. Patent Application Number 10/753,781, filed January 8, 2004.

BACKGROUND OF THE INVENTION

10 Field of the Invention. The present invention generally relates to aircraft cargo loading apparatus and, more particularly, to loaders comprising conveyor platforms capable of being raised and lowered relative to a cargo door of the aircraft for loading and off-loading cargo.

Description of the Related Art. In the air cargo industry, loaders are used to load cargo onto an aircraft and unload cargo from the aircraft. As used herein, therefore, the
15 term "loader" is directed to apparatus for performing either or both of these functions. Generally, two types of apparatus of this type are in use. The first is a single platform loader which is elevated between a position adjacent the ground and a position at the height of the cargo door sill or lower edge. The second is a two platform loader in which a first platform is maintained at the level of the cargo door sill and a second platform is
20 raised and lowered with respect to the first platform. Cargo to be unloaded from the aircraft is therefore transferred between the cargo compartment of the aircraft and the first platform and then transferred from the first platform to the second platform when the second platform is in its elevated position. The second platform is then lowered and the cargo is off-loaded. The loading procedure is reversed.

25 The current loaders have various drawbacks, especially with respect to accommodating larger aircraft being designed and manufactured today. For example, the cargo door of such larger aircraft is at a much higher level than in the past. Also, due to the larger size of the aircraft and correspondingly larger carrying capacities, much higher volumes of cargo must be loaded and off-loaded. Ideally, such loading and off-loading
30 should be accomplished in a comparable amount of time to smaller aircraft. With current loaders, manufacturing a single, adjustable platform such that it can raise and lower to and from much greater heights presents practical problems related to stability and size

requirements. In addition, the increased amount of required travel takes additional time, or increased speed, both of which may be undesirable.

For at least these reasons, it would be desirable to provide an aircraft loader capable of effectively handling the cargo loading and unloading needs of even the largest aircraft while maintaining low loading and unloading time requirements for loading and unloading the cargo.

BRIEF SUMMARY OF THE INVENTION

The present invention is generally directed to an aircraft cargo loader having at least three height adjustable, generally horizontal platform structures. Each platform structure may be raised and lowered during loading and/or unloading operations. More specifically, a first generally horizontal platform structure is adjustable in height between ground level and a first elevated position. A second generally horizontal platform structure is positioned adjacent to the first generally horizontal platform structure and is adjustable in height independently from the first generally horizontal platform structure. A third generally horizontal platform structure is positioned adjacent to the second generally horizontal platform structure and is adjustable in height relative to the first and second generally horizontal platform structures. In various embodiments, the second generally horizontal platform structure is adjustable in height relative to the first platform structure between the first elevated position and a second elevated position higher than the first elevated position and the third generally horizontal platform structure is adjustable in height between the second elevated position and a third elevated position higher than the second elevated position. Alternatively, the second and third height adjustable platform structures may both remain at the second elevated position during loading and unloading. For example, this would be desirable if a lower level cargo door need to be accessed at the second elevated position.

The first, second, and third generally horizontal platform structures may be carried by a mobile vehicle, which itself could be self-propelled or otherwise moved, such as by towing. In general practice, each of the first, second, and third generally horizontal platform structures further includes a conveyor, which may be a powered conveyor, rollers on an upper surface of the platform structure, or other conveying mechanisms.

The invention contemplates various embodiments and arrangements of the multiple, height adjustable platform structures. As one example, the first, second, and third generally horizontal platform structures are positioned serially with respect to each

other such that cargo is moved in a generally straight line between the first, second, and third generally horizontal platform structures. As another example, the first, second and third generally horizontal platform structures are positioned such that cargo is moved in a generally straight line between the first and second generally horizontal platform structures and in a transverse direction relative to the generally straight line when moving
5 between the second and third generally horizontal platform structures. In another embodiment, two lower ground level platform structures are used in conjunction with a single upper level platform structure to increase transfer speeds. In other embodiments, a fourth generally horizontal platform structure is positioned adjacent to the third generally horizontal platform structure and is adjustable in height relative to the first, second, and
10 third generally horizontal platform structures between the third elevated position and a fourth elevated position higher than the third elevated position. Alternatively, the third and fourth platform structures may remain at the third elevated position during operation. The fourth generally horizontal platform structure may be positioned such that the cargo
15 moves in the transverse direction when moving between the third and fourth generally horizontal platform structures. Alternatively, the fourth generally horizontal platform structure may be positioned such that the cargo moves in a direction parallel to the generally straight line when moving between the third and fourth generally horizontal platform structures.

It may be possible for one to describe the elements of an exemplary inventive embodiment as an aircraft cargo loading vehicle comprising a movable base structure having top portion elevated above ground level, a bottom portion with wheels adapted to allow movement of the base structure with respect to the aircraft, front portion, and a rear portion located opposite to said front portion; a first generally horizontal platform structure connected to the rear portion of said base structure and adjustable in height between ground level and a first elevated position; a second generally horizontal platform structure carried on the top portion of said base structure and positioned adjacent to said first generally horizontal platform structure to allow transfer of cargo to and from said first generally horizontal platform structure, said second generally horizontal platform structure adjustable in height independently from said first generally horizontal platform structure from said first elevated position to a second, higher elevated position suitable for transferring cargo to and from a cargo compartment of the aircraft; a third generally horizontal platform structure carried on the top portion of the base structure and positioned

adjacent to said second generally horizontal platform structure, said third generally horizontal platform structure independently adjustable in height from said first elevated position to said second, higher elevated position; and wherein said second and third generally horizontal platform structures are sized and configured to independently hold respective loads of cargo such that a first load of cargo having a size which occupies at least about half the area of said second generally horizontal platform structure may be placed on and solely supported by said second generally horizontal platform structure and a second load of cargo of at least the same size as said first load of cargo may be placed on and solely supported by said third generally horizontal platform structure when said second and third platform structures are positioned at said second, higher elevated position. Additionally, such an embodiment may include that said third generally horizontal platform structure is adjustable between the second elevated position and a third elevated position higher than said second elevated position; or that each of said first, second, and third generally horizontal platform structures further comprises a conveyor on an upper surface thereof; or that said first, second, and third generally horizontal platform structures are positioned serially with respect to each other such that cargo is moved in a generally straight line between said first, second, and third generally horizontal platform structures; or that a fourth generally horizontal platform structure positioned adjacent to said third generally horizontal platform structure and adjustable in height relative to said first, second, and third generally horizontal platform structures; or that said first, second and third generally horizontal platform structures are positioned such that cargo is moved in a generally straight line between said first and second generally horizontal platform structures and in a transverse direction relative to the generally straight line when moving between said second and third generally horizontal platform structures, which may also include that a fourth generally horizontal platform structure positioned adjacent to said third generally horizontal platform structure and adjustable in height relative to said first, second, and third generally horizontal platform structures, said fourth generally horizontal platform structure positioned such that the cargo moves in the transverse direction when moving between said third and fourth generally horizontal platform structures; or that a fourth generally horizontal platform structure positioned adjacent to said third generally horizontal platform structure and adjustable in height relative to said first, second, and third generally horizontal platform structures, said fourth generally horizontal platform structure positioned such that the cargo moves in a direction parallel to the generally

straight line when moving between said third and fourth generally horizontal platform structures.

Various methods of loading and unloading aircraft cargo are also contemplated by this invention. Generally, a method of transferring cargo into or out of an aircraft cargo compartment according to the invention can comprise transferring the cargo between a first generally horizontal platform structure and a second generally horizontal platform structure at a first elevated position above ground level. The cargo is transferred between the second generally horizontal platform structure and a third generally horizontal platform structure at a second elevated position higher than the first elevated position. The methods of this invention may be used to effectively increase the height through which cargo may be transferred and/or also increase the speed at which cargo may be loaded into or off-loaded from the aircraft. Increased cargo transfer speeds are attained since multiple loading and unloading operations may be performed while one or more intermediate platform structures of the loader move between upper and lower cargo transfer positions.

It may be possible for one to describe the elements of an exemplary inventive method as a method of transferring cargo out of an aircraft cargo compartment, comprising the steps of transferring a first load of cargo out of the aircraft cargo compartment onto a first generally horizontal platform structure at a first elevated position above ground level such that the first load of cargo is solely supported by the first generally horizontal platform structure; transferring the first load of cargo from the first generally horizontal platform structure to a second generally horizontal platform structure at the first elevated position above ground level; lowering the second generally horizontal platform structure with the first load of cargo to a second elevated position above ground level which is lower than the first elevated position; transferring the first load of cargo from the second generally horizontal platform structure to a third generally horizontal platform structure at the second elevated position above ground level; lowering the first load of cargo on the third generally horizontal platform structure from the second elevated position to ground level; and transferring the first load of cargo off of the third generally horizontal platform structure. Additional elements of such a method may include wherein transferring the first load of cargo between the first generally horizontal platform structure and the second generally horizontal platform structure further comprises transferring the first load of cargo in a generally straight line away from the aircraft cargo compartment and in a direction perpendicular to the length of the aircraft; or wherein transferring the

load of cargo between the second generally horizontal platform structure and the third generally horizontal platform structure further comprises transferring the first load of cargo in the generally straight line away from the aircraft cargo compartment; or wherein method further comprises carrying a second load of cargo on the first generally horizontal platform while the first load of cargo is transferred from the second generally horizontal platform to the third generally horizontal platform; or wherein transferring the first load of cargo between the first generally horizontal platform structure and the second generally horizontal platform structure further comprises transferring the first load of cargo in a direction generally parallel to the length of the aircraft.

It may be possible for one to describe the elements of an alternate exemplary inventive method as a method of transferring cargo into an aircraft cargo compartment, comprising transferring a first load of cargo onto a first generally horizontal platform structure at ground level; raising the first load of cargo on the first generally horizontal platform structure from ground level to a first elevated position above ground level; transferring the first load of cargo from the first generally horizontal platform structure to a second generally horizontal platform structure at the first elevated position above ground level; raising the second generally horizontal platform structure with the first load of cargo to a second elevated position higher than the first elevated position and at a level suitable for transferring the first load of cargo into the cargo compartment of the aircraft; transferring the first load of cargo from the second generally horizontal platform structure to a third generally horizontal platform structure at the second elevated position above ground level; solely supporting the first load of cargo with the third generally horizontal platform structure at the second elevated position; and transferring the first load of cargo into the aircraft cargo compartment from the third generally horizontal platform structure at the second elevated position. Additional elements of such a method may include carrying a second load of cargo on the first generally horizontal platform while the first load of cargo is transferred from the second generally horizontal platform to the third generally horizontal platform; or wherein transferring the first load of cargo between the first generally horizontal platform structure and the second generally horizontal platform structure further comprises transferring the first load of cargo in a direction generally parallel to the length of the aircraft; or wherein transferring the first load of cargo between the first generally horizontal platform structure and the second generally horizontal platform structure further comprises transferring the first load of cargo in a generally

straight line toward the aircraft cargo compartment and in a direction perpendicular to the length of the aircraft, which may include the additional elements wherein transferring the first load of cargo between the second generally horizontal platform structure and the third generally horizontal platform structure further comprises transferring the first load of cargo in the generally straight line toward the aircraft cargo compartment.

It may be possible for one to describe the elements of an alternate exemplary inventive method as a method of transferring cargo into or out of an aircraft, said aircraft having cargo door and a cargo compartment, said cargo door accessible at a level higher than a widest portion of said aircraft, said method comprising positioning a first generally horizontal platform at an elevated height above said widest portion, wherein a movable base structure having top portion elevated above ground level, a bottom portion with wheels adapted to allow movement of the base structure with respect to the aircraft, front portion, and a rear portion located opposite to said front portion, said first generally horizontal platform structure carried on the top portion of the base structure, above said front portion, and a second generally horizontal platform structure carried on the top portion of said base structure and positioned adjacent to said first generally horizontal platform structure to allow transfer of cargo to and from said first generally horizontal platform structure, each of said first and second generally horizontal platform structure adjustable in height independently from the other said generally horizontal platform structure from a first elevated position to a second, higher elevated position suitable for transferring cargo to and from a cargo compartment of the aircraft; positioning said movable base structure adjacent to the side of said aircraft such as to allow transfer of cargo between said first generally horizontal platform and said cargo compartment after said first generally horizontal platform is at said elevated height; and raising and lowering said second generally horizontal platform to the elevated height of said first generally horizontal platform in order to transfer cargo to or from said first generally horizontal platform positioned at said elevated height.

The invention also contemplates an aircraft cargo loading device comprised of a first component having a movable base structure having top portion elevated above ground level, a bottom portion with wheels adapted to allow movement of the base structure with respect to the aircraft, front portion, and a rear portion located opposite to said front portion; a first generally horizontal platform structure carried on the top portion of said base structure adjustable in height from a first elevated position to a second, higher

elevated position suitable for transferring cargo to and from a cargo compartment of the aircraft. a second generally horizontal platform structure carried on the top portion of the base structure and positioned adjacent to said first generally horizontal platform structure, said second generally horizontal platform structure independently adjustable in height
5 from said first elevated position to said second, higher elevated position; said second generally horizontal platform structure positioned adjacent to said first generally horizontal platform structure to allow transfer of cargo to and from said first generally horizontal platform structure. This first component, having multiple lifting platforms atop a movable portion, may be adapted to couple to a prior art loader having at least one
10 generally horizontal platform structure, so that both the first component and the prior art loader may be controlled by an operator at either an operator station of the first component or an operator station of the prior art loader. An example of a potentially suitable prior art loader is a Commander 15, manufactured by FMC Technologies Inc. In this fashion the prior art loader would serve as the third generally horizontal platform structure described
15 above for transporting cargo to and from the platforms located atop the movable portion.

Various additional features, methodology, and attendant advantages will become more readily apparent upon further review of a detailed description of representative embodiments of the invention as set forth below.

BRIEF DESCRIPTION OF DRAWINGS

20 Fig. 1 is a perspective view of a first embodiment of the invention in the form of a platform structure loader having three height adjustable platform structures.

Fig. 2 is a schematic top view of a loader as shown in Fig. 1.

Fig. 3 is a schematic top view of a first alternative loader, similar to that shown in Fig. 1, but illustrating the platform structures positioned along the length of the aircraft.

25 Fig. 4 is a schematic top view of a second alternative loader having three height adjustable platform structures.

Fig. 5 is a schematic top view of a third alternative loader having three height adjustable platform structures.

30 Fig. 6 is a schematic top view of a fourth alternative loader having four height adjustable platform structures.

Fig. 7 is a schematic top view of a fifth alternative loader having four height adjustable platform structures.

Fig. 8 is an alternative schematic top view of a loader as shown in Fig. 1.

Fig. 9 is an alternative schematic top view of a loader as shown in Fig. 4.

DETAILED DESCRIPTION OF EXEMPLARY EMBODIMENTS

Figs. 1, 2 and 8 illustrate a cargo loader 10 positioned adjacent to an aircraft 12. Cargo loader 10 includes three generally horizontal platform structures 14, 16, 18 each being vertically adjustable between at least two positions. Respective upper surfaces 14a, 16a, 18a may include conveying mechanisms, which may be powered or non-powered, such as roller mechanisms as schematically shown in Fig. 1. Each platform structure 14, 16, 18 is carried by a vehicle 20 which may be a powered, self-propelled vehicle or may be a non-self-propelled vehicle which could be towed by another vehicle. By way of loader 10 cargo 22 may be loaded and/or unloaded from an aircraft cargo compartment 24 through a door 26.

Lower cargo door 26' is shown adjacent to cargo door 26 in Figs. 1 and 2 to illustrate the potential for a cargo aircraft to have multiple cargo levels. In such aircraft, cargo doors to access either the upper or lower deck may not be positioned directly adjacent to each other.

Fig. 2 shows a horizontal width w of aircraft 12. In larger aircraft, for instance, ones having multiple cargo levels, width w may be greater than a width found on smaller aircraft with single cargo levels. A line representing the widest portion 13 of the exterior of aircraft 12 is shown in Figs. 1 and 2. Figs. 1, 2, 8 and 9 show how the greater height and width of the exemplary larger aircraft 12 relate to the positioning of loader 10. Of particular note is that a platform structure closest to the aircraft 12 may be positioned so as to be partially above the widest portion 13.

Platform structures 14, 16, 18 are capable of being raised and lowered through the use of scissor lift mechanisms 30, 32, 34, conventional hydraulic cylinder mechanisms, mechanical lift mechanisms or other suitable lift mechanisms such as electric motors and appropriate drive systems (not shown). Multiple platform structures 16, 18 sit atop, or are perched upon, a movable portion, such that these perched platform structures 16, 18 may reach a higher elevation while employing scissor lift mechanisms 32, 34 of similar reach as ground scissor lift mechanism 30. Exemplary operator station 78 is provided to permit an operator suitable positioning and protection during loading or unloading operation.

In use, for example, to unload cargo 22 from aircraft 12, cargo 22 is first transferred from cargo compartment 24 to platform structure 18. Platform structure 18 is lifted and remains staged at the aircraft door sill height. Platform structure 16 lifts to the

height of platform structure 18 and cargo 22 is conveyed onto platform structure 16. Platform structure 16 is then lowered to the upper edge 36 of vehicle 20 or any other suitable transfer height. Platform structure 14 moves between upper edge 36 or any other suitable transfer height and an appropriate ground level position which may be very close to ground level or at some intermediate off-loading position between the ground surface, for example, and upper edge 36. At this ground level location, cargo 22 may be off-loaded from platform structure 14 onto another vehicle, for example, and conveyed to another location. It will be appreciated that the loading of cargo 22 onto aircraft 12 may be conducted using a similar reverse stair-stepping procedure. To further increase the speed at which cargo 22 is either off-loaded from aircraft 12 or loaded onto aircraft 12, one or more of the platform structures 14, 16, 18 may be raised or lowered simultaneously with one or more of the other platform structures 14, 16, 18 during the loading or unloading procedure. For example, while platform structure 16 is raising between upper edge 36 and platform structure 18, platform structure 14 may be lowering to ground level to receive the next cargo load. Such simultaneous upward and downward movement of the various platform structures 14, 16, 18 ensures that the most efficient and timely movement of cargo takes place between the various platform structures 14, 16, 18 as well as onto and off of loader 10. Additionally, by permitting an operator (not shown) to take complete control of an item of cargo 22 and move it to the ground while loader 10 remains staged against aircraft 12 may free aircraft crew members to work at moving a next item of cargo to cargo door 26 without leaving an unsecured item of cargo 22 unattended.

Similarly, during loading and unloading operation to a lower level cargo door 26', perched platform structures 16, 18 are positioned at or near the level of cargo door 26' in their lower elevated height. Shuttle platform 14 may extend up to the level of perched platform structures 16, 18 while they are docked at cargo door 26'. During unloading operation, perched platforms 16, 18 may remain at the same level so as to permit multiple cargo items 22 to be removed from the aircraft cargo compartment 24 in rapid succession. Shuttle platform 14 may have a greater capacity so as to be able to take all the items staged on perched platforms 16, 18, leaving perched platforms 16, 18 vacant to receive more items of cargo 22, while shuttle platform 14 transports the prior cargo items 22 to the next lower level. During loading operation, perched platforms 16, 18 may remain at the same level so as to permit multiple cargo items 22 delivered from shuttle platform 14 and held for insertion and securing within the aircraft cargo compartment 24. Shuttle platform

14 may have a greater capacity so as to be able to take as many items as may be staged on perched platforms 16, 18, making items of cargo 22 available as soon as the crew (not shown) is prepared to receive the cargo items 22 into the cargo compartment 24.

Fig. 1, 2 and 8 illustrate how the body of aircraft 12 may extend into the space under elevated platform structure 18 and the upper edge 36 of vehicle 20. In such instances platform structure 18 is raised to the approximate height of cargo door 26 before cargo loader 10 is moved into position adjacent to aircraft 12. In such instances platform structure 18 remains at an elevated height while cargo loader 10 is adjacent to aircraft 12 so as to not cause damage to aircraft 12 by making undesirable contact with the portion of aircraft 12 that may extend under raised platform 18.

An operator (not shown) may control the entire loading operation of loader 10 from operator stations 78, to include, but not limited to, movement of vehicle 20, independent raising and lowering of platform structures 14, 16, and horizontal and rotational conveyance and positioning of cargo 22.

Fig. 3 illustrates an alternative embodiment which essentially moves platform structures 14', 16', 18' into a parallel arrangement to aircraft 12 such that the cargo (not shown) moves in a generally straight line direction parallel to the length of the aircraft 12 as opposed to the generally straight line direction perpendicular to the aircraft 12 as shown in Figs. 1 and 2. All other aspects of the structure and operation of the embodiment shown in Fig. 3 may be the same as described above.

Figs. 4 and 9 illustrate another arrangement of platform structures 40, 42, 44 arranged or positioned with respect to the cargo door 26 of aircraft 12. In this embodiment, platform structures 40 and 42 both move between ground level positions and an intermediate upper level position higher than ground level to respectively transfer cargo to or from upper level platform structure or bridge 44, which is also height adjustable. Specifically, platform structure 44 is also adjustable in height so as to maintain its level with the aircraft door sill height during cargo loading and unloading operations. Alternatively, in Fig. 4, platform structure 44 could also move between cargo door 26 and the respective elevated positions of platform structures 40, 42 which may be below cargo door 26. Therefore, when one of the platform structures 40 or 42 is being used to transfer cargo to or from platform structure 44, the other of the platform structures 40 or 42 may be used to transfer cargo to or from a vehicle or other apparatus at ground level. This significantly increases loading and unloading speeds.

Fig. 9, on the other hand, illustrates how the body of aircraft 12 may extend into the space under elevated platform structure 44, as in Fig. 2. In such instances platform structure 44 is raised to the approximate height of cargo door 26 before cargo loader 10 is moved into position adjacent to aircraft 12. In such instances platform structure 44 remains at an elevated height while cargo loader 10 is adjacent to aircraft 12 so as to not cause damage to aircraft 12 by making undesirable contact with the portion of aircraft 12 that may extend under raised platform 44.

Fig. 5 illustrates another alternative embodiment of a loader comprising first, second and third platform structures 50, 52, 54 positioned with respect to the cargo door 26 of aircraft 12. In this embodiment, platform structure 50 may be the lower level platform structure. Platform structure 52 may be the intermediate level platform structure, and platform structure 54 is the upper level or bridge platform structure. Each platform structure is independently height adjustable as described in connection with Fig. 1 and is used in the same manner described with respect to Fig. 1. The difference is that cargo moves in a generally straight line fashion between platform structures 50 and 52 and moves in a direction transverse to the straight line direction when transferring between platform structures 52 and 54. All other aspects and use of this embodiment may be the same as described in connection with Figs. 1 and 2.

Fig. 6 illustrates another embodiment of a loader comprising four height adjustable platform structures 60, 62, 64, 66 positioned with respect to the cargo door of an aircraft 12. This embodiment which utilizes four platform structures may be useful, for example, when particularly high elevations are necessary for very large aircraft. Platform structure 60 may be the lower level platform structure. Platform structure 62 may be a first intermediate level platform structure which is height adjustable between an upper level position of lower platform structure 60 and a lower level position of a second intermediate platform structure 64. Platform structure 64 is then movable between its lower level position and an upper level position raised therefrom. Upper level platform structure or bridge 66 is height adjustable between a lower level position (which is at the upper level position of platform structure 64) and the door sill of cargo door 26. The use of this loader is the same as described in connection with Figs. 1 and 2, except that one additional intermediate level platform structure is used and, therefore, additional "stair steps" are provided for reaching additional heights and increasing cargo transfer speed.

Fig. 7 illustrates another embodiment of a loader including four height adjustable platform structures 70, 72, 74, 76 positioned with respect to the cargo door 26 of aircraft 12. This embodiment is similar to the embodiment shown in Fig. 4, except that an intermediate level platform structure 70 is positioned between the respective parallel lower level platform structures 40, 42 and the upper level or bridge platform structure 44. The principles of operation associated with this embodiment are therefore the same as described above with respect to Fig. 4, except that additional heights may be reached due to the addition of height adjustable intermediate platform structure 70. In this regard, platform structure 70 will be adjustable between the respective upper level positions of platform structures 40, 42 and the lower level position of platform structure 44. If necessary, platform structure 44 will then be movable to an upper level position adjacent to the door sill of cargo door 26. Alternatively, platform 44 may remain at the height of the door sill during the entire loading or unloading procedure.

In each of the above described embodiments, the platform structure closest to the door 26 may be of a size that it may not solely support an entire cargo container. It may, for example, only act as a short interface between the cargo compartment and the next platform structure. Such a short forward platform structure would thereby serve to space the next platform structure a safe distance from the aircraft fuselage. Thus, as described herein, the transferring, loading and unloading of cargo is not meant to be limited to the full support of a cargo item on a platform structure. It will also be appreciated that each platform structure may be comprised of one or more discrete platforms. It will also be appreciated that the comparative dimensions of the various platforms may vary without departing from the spirit of the invention.

While the present invention has been illustrated by a description of various preferred embodiments and while these embodiments has been described in some detail, it is not the intention of the Applicants to restrict or in any way limit the scope of the appended claims to such detail. Additional advantages and modifications will readily appear to those skilled in the art. The various features of the invention may be used alone or in numerous combinations depending on the needs and preferences of the user. This has been a description of the present invention, along with the preferred methods of practicing the present invention as currently known. However, the invention itself should only be defined by the appended claims. Accordingly, the protection sought herein is as set forth in the claims below.

What is claimed is:

1. An aircraft cargo loading vehicle comprising:
 - a movable base structure having top portion elevated above ground level, a bottom portion with wheels adapted to allow movement of the base structure with respect to the aircraft, front portion, and a rear portion located opposite to said front portion;
 - a first generally horizontal platform structure connected to the rear portion of said base structure and adjustable in height between ground level and a first elevated position;
 - a second generally horizontal platform structure carried on the top portion of said base structure and positioned adjacent to said first generally horizontal platform structure to allow transfer of cargo to and from said first generally horizontal platform structure, said second generally horizontal platform structure adjustable in height independently from said first generally horizontal platform structure from said first elevated position to a second, higher elevated position suitable for transferring cargo to and from a cargo compartment of the aircraft;
 - a third generally horizontal platform structure carried on the top portion of the base structure and positioned adjacent to said second generally horizontal platform structure, said third generally horizontal platform structure independently adjustable in height from said first elevated position to said second, higher elevated position; and
 - wherein said second and third generally horizontal platform structures are sized and configured to independently hold respective loads of cargo such that a first load of cargo having a size which occupies at least about half the area of said second generally horizontal platform structure may be placed on and solely supported by said second generally horizontal platform structure and a second load of cargo of at least the same size as said first load of cargo may be placed on and solely supported by said third generally horizontal platform structure when said second and third platform structures are positioned at said second, higher elevated position.
2. The aircraft cargo loading vehicle of claim 1, wherein:
 - an operator station;
 - operation of said first, second and third generally horizontal platform structure controllable from one said operator station.
3. The aircraft cargo loading vehicle of claim 2, wherein:
 - operation of movable base structure controllable from one said operator station.
4. The aircraft cargo loading vehicle of claim 1, wherein:

said third generally horizontal platform structure is adjustable between the second elevated position and a third elevated position higher than said second elevated position.

5. The aircraft cargo loading vehicle of claim 1, wherein:

each of said first, second, and third generally horizontal platform structures further comprises a conveyor on an upper surface thereof.

6. The aircraft cargo loading vehicle of claim 1, wherein:

said first, second, and third generally horizontal platform structures are positioned serially with respect to each other such that cargo is moved in a generally straight line between said first, second, and third generally horizontal platform structures.

7. The aircraft cargo loading vehicle of claim 1, wherein:

said first, second and third generally horizontal platform structures are positioned such that cargo is moved in a generally straight line between said first and second generally horizontal platform structures and in a transverse direction relative to the generally straight line when moving between said second and third generally horizontal platform structures.

8. The aircraft cargo loading vehicle of claim 7, further comprising:

a fourth generally horizontal platform structure positioned adjacent to said third generally horizontal platform structure and adjustable in height relative to said first, second, and third generally horizontal platform structures, said fourth generally horizontal platform structure positioned such that the cargo moves in the transverse direction when moving between said third and fourth generally horizontal platform structures.

9. The aircraft cargo loading vehicle of claim 7, further comprising:

a fourth generally horizontal platform structure positioned adjacent to said third generally horizontal platform structure and adjustable in height relative to said first, second, and third generally horizontal platform structures, said fourth generally horizontal platform structure positioned such that the cargo moves in a direction parallel to the generally straight line when moving between said third and fourth generally horizontal platform structures.

10. The aircraft cargo loading vehicle of claim 1, further comprising:

a fourth generally horizontal platform structure positioned adjacent to said third generally horizontal platform structure and adjustable in height relative to said first, second, and third generally horizontal platform structures.

11. A method of transferring cargo out of an aircraft cargo compartment, comprising:

transferring a first load of cargo out of the aircraft cargo compartment onto a first generally horizontal platform structure at a first elevated position above ground level such that the first load of cargo is solely supported by the first generally horizontal platform structure;

5 transferring the first load of cargo from the first generally horizontal platform structure to a second generally horizontal platform structure at the first elevated position above ground level;

lowering the second generally horizontal platform structure with the first load of cargo to a second elevated position above ground level which is lower than the first
10 elevated position;

transferring the first load of cargo from the second generally horizontal platform structure to a third generally horizontal platform structure at the second elevated position above ground level;

lowering the first load of cargo on the third generally horizontal platform structure
15 from the second elevated position to ground level; and

transferring the first load of cargo off of the third generally horizontal platform structure.

12. The method of claim 11, wherein transferring the first load of cargo between the first generally horizontal platform structure and the second generally horizontal
20 platform structure further comprises:

transferring the first load of cargo in a generally straight line away from the aircraft cargo compartment and in a direction perpendicular to the length of the aircraft.

13. The method of claim 11, wherein transferring the load of cargo between the second generally horizontal platform structure and the third generally horizontal platform
25 structure further comprises:

transferring the first load of cargo in the generally straight line away from the aircraft cargo compartment.

14. The method of claim 11, further comprising:
carrying a second load of cargo on the first generally horizontal platform while the
30 first load of cargo is transferred from the second generally horizontal platform to the third generally horizontal platform.

15. The method of claim 11, wherein transferring the first load of cargo between the first generally horizontal platform structure and the second generally horizontal

platform structure further comprises:

transferring the first load of cargo in a direction generally parallel to the length of the aircraft.

16. A method of transferring cargo into an aircraft cargo compartment, comprising:

5 transferring a first load of cargo onto a first generally horizontal platform structure at ground level;

raising the first load of cargo on the first generally horizontal platform structure from ground level to a first elevated position above ground level;

10 transferring the first load of cargo from the first generally horizontal platform structure to a second generally horizontal platform structure at the first elevated position above ground level;

raising the second generally horizontal platform structure with the first load of cargo to a second elevated position higher than the first elevated position and at a level suitable for transferring the first load of cargo into the cargo compartment of the aircraft;

15 transferring the first load of cargo from the second generally horizontal platform structure to a third generally horizontal platform structure at the second elevated position above ground level;

solely supporting the first load of cargo with the third generally horizontal platform structure at the second elevated position; and

transferring the first load of cargo into the aircraft cargo compartment from the third generally horizontal platform structure at the second elevated position.

20 17. The method of claim 16, wherein transferring the first load of cargo between the first generally horizontal platform structure and the second generally horizontal platform structure further comprises:

transferring the first load of cargo in a generally straight line toward the aircraft cargo compartment and in a direction perpendicular to the length of the aircraft.

25 18. The method of claim 17, wherein transferring the first load of cargo between the second generally horizontal platform structure and the third generally horizontal platform structure further comprises:

transferring the first load of cargo in the generally straight line toward the aircraft cargo compartment.

30 19. The method of claim 16, further comprising:

carrying a second load of cargo on the first generally horizontal platform while the

first load of cargo is transferred from the second generally horizontal platform to the third generally horizontal platform.

20. The method of claim 16, wherein transferring the first load of cargo between the first generally horizontal platform structure and the second generally horizontal platform structure further comprises:

transferring the first load of cargo in a direction generally parallel to the length of the aircraft.

21. A method of transferring cargo into or out of an aircraft, said aircraft having cargo door and a cargo compartment, said cargo door accessible at a level higher than a widest portion of said aircraft, said method comprising:

positioning a first generally horizontal platform at an elevated height above said widest portion, wherein a movable base structure having top portion elevated above ground level, a bottom portion with wheels adapted to allow movement of the base structure with respect to the aircraft, front portion, and a rear portion located opposite to said front portion, said first generally horizontal platform structure carried on the top portion of the base structure, above said front portion, and a second generally horizontal platform structure carried on the top portion of said base structure and positioned adjacent to said first generally horizontal platform structure to allow transfer of cargo to and from said first generally horizontal platform structure, each of said first and second generally horizontal platform structure adjustable in height independently from the other said generally horizontal platform structure from a first elevated position to a second, higher elevated position suitable for transferring cargo to and from a cargo compartment of the aircraft;

positioning said movable base structure adjacent to the side of said aircraft such as to allow transfer of cargo between said first generally horizontal platform and said cargo compartment after said first generally horizontal platform is at said elevated height; and

raising and lowering said second generally horizontal platform to the elevated height of said first generally horizontal platform in order to transfer cargo to or from said first generally horizontal platform positioned at said elevated height.

1/4

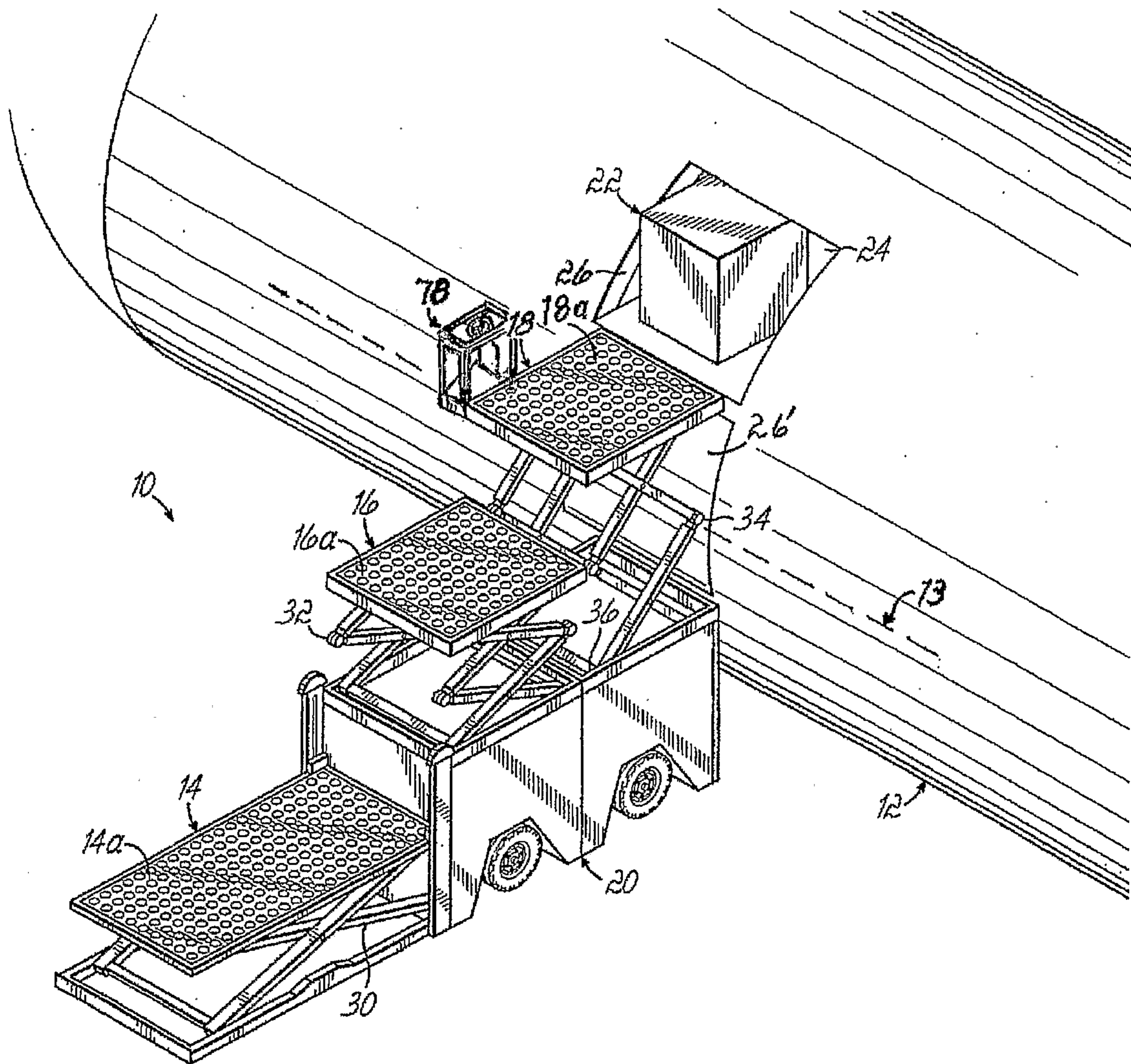

FIG. 1

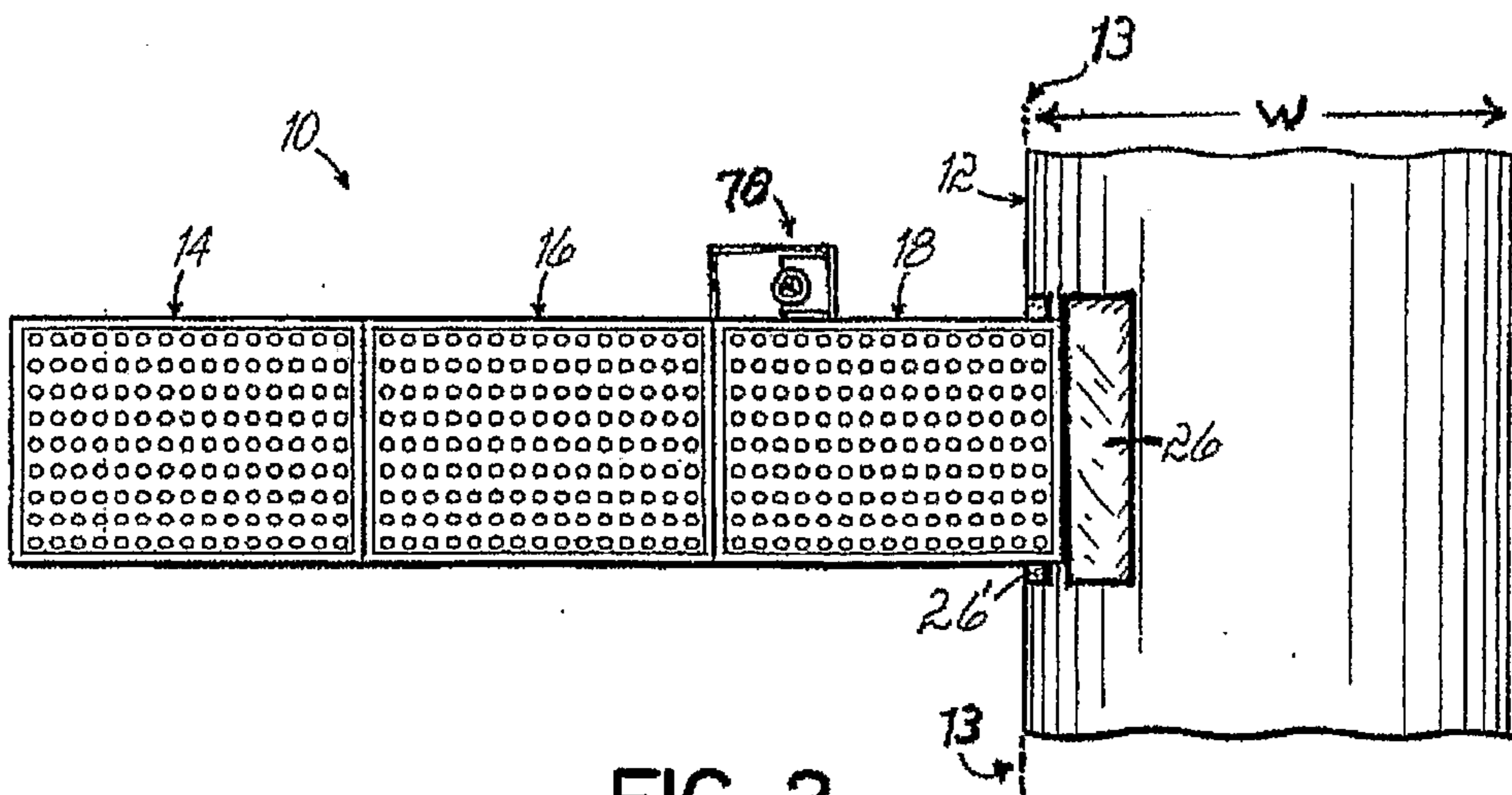

FIG. 2

2/4

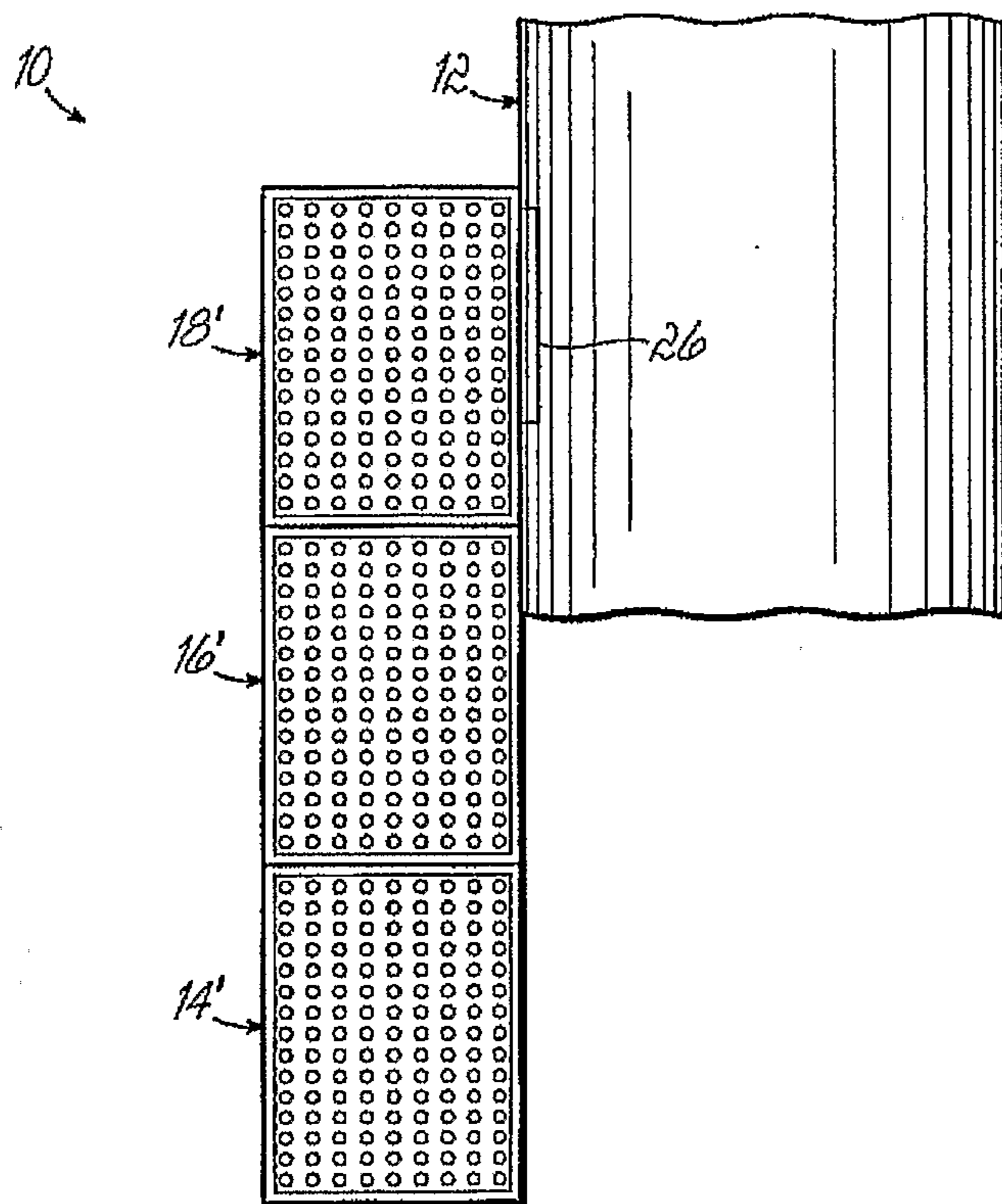

FIG. 3

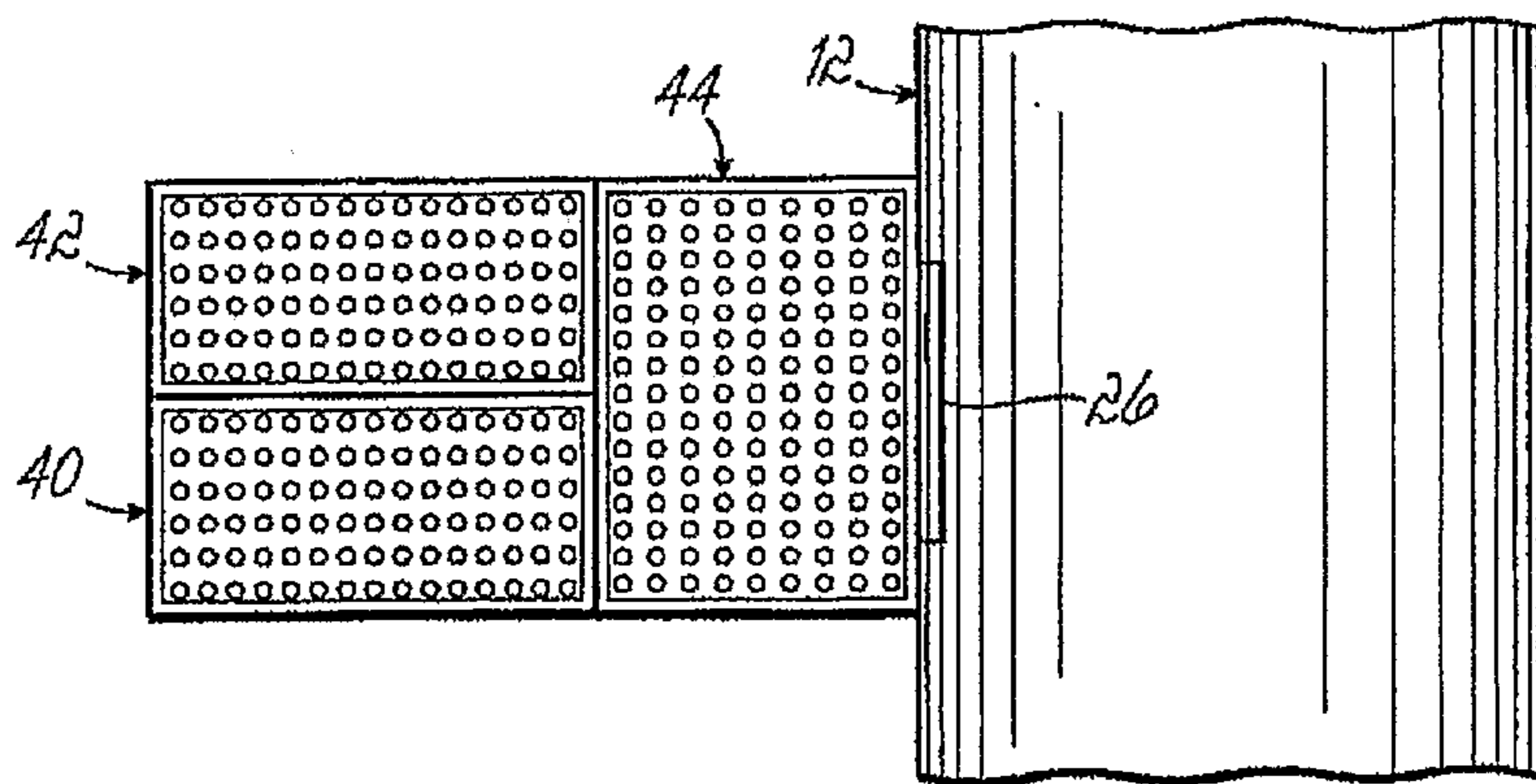

FIG. 4

3/4

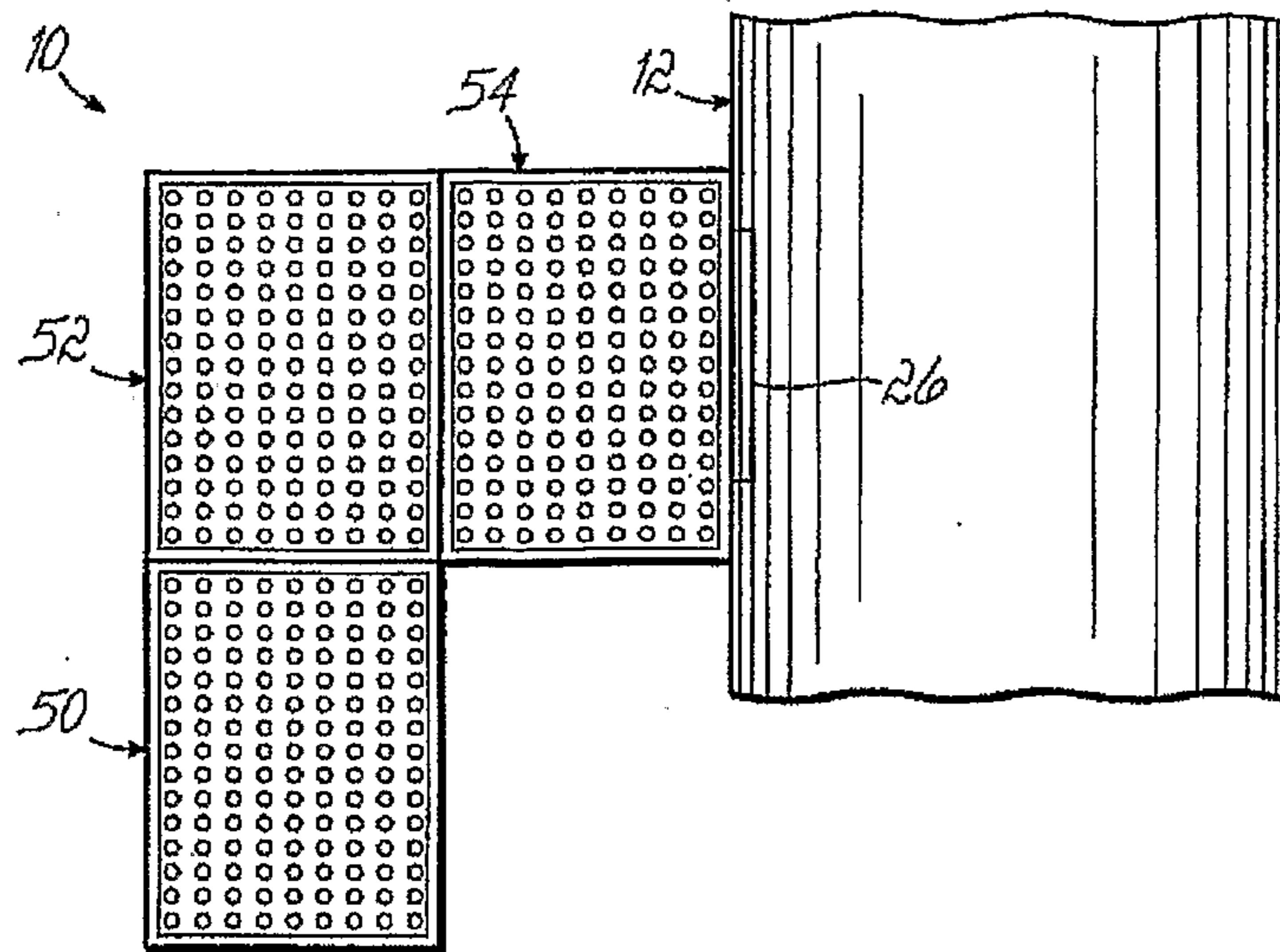

FIG. 5

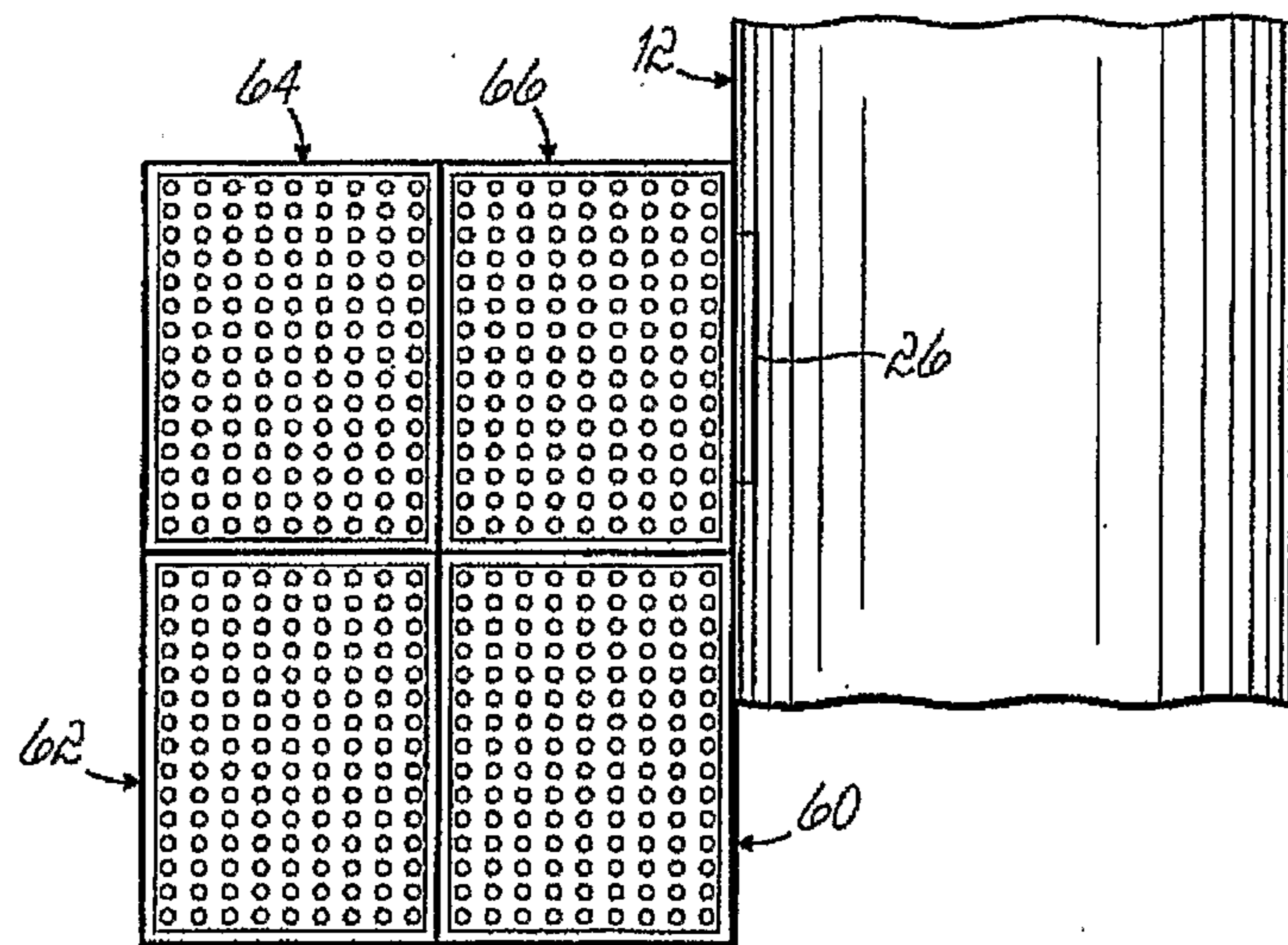

FIG. 6

4/4

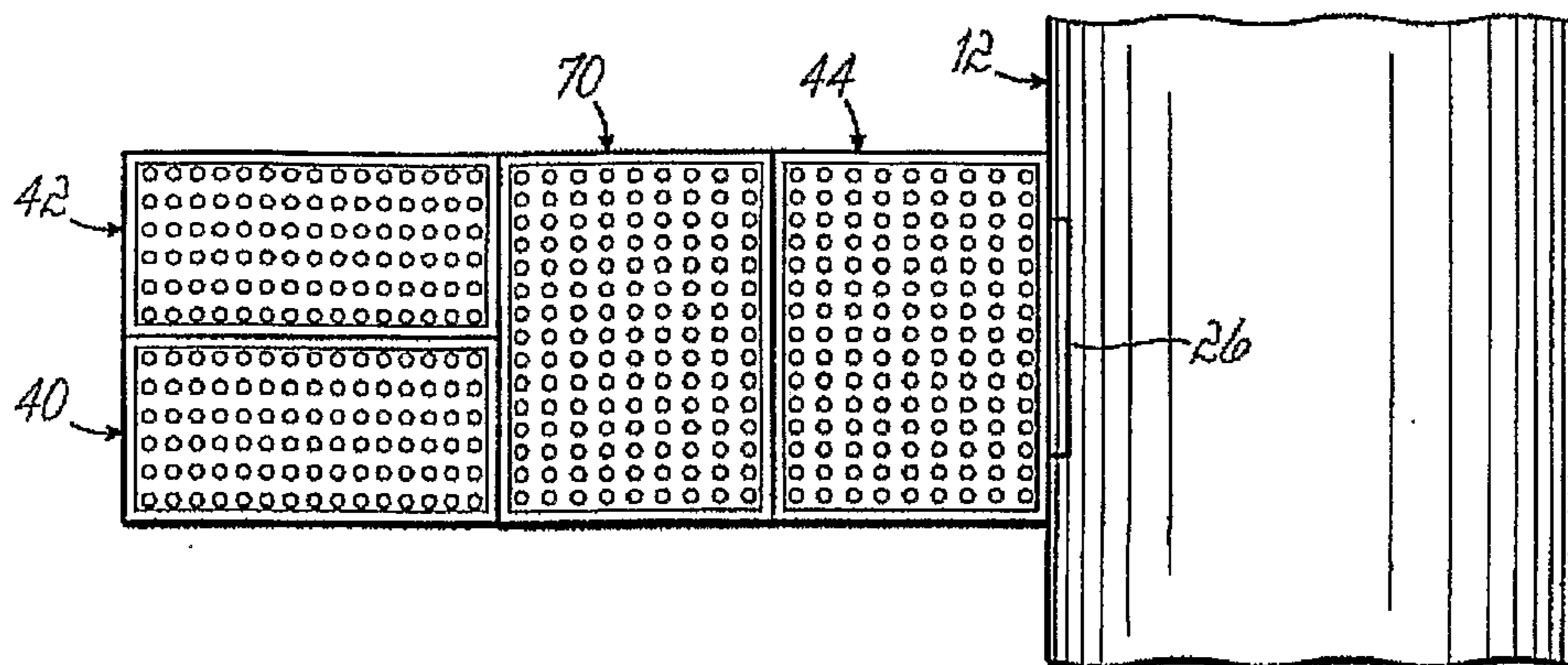

FIG. 7

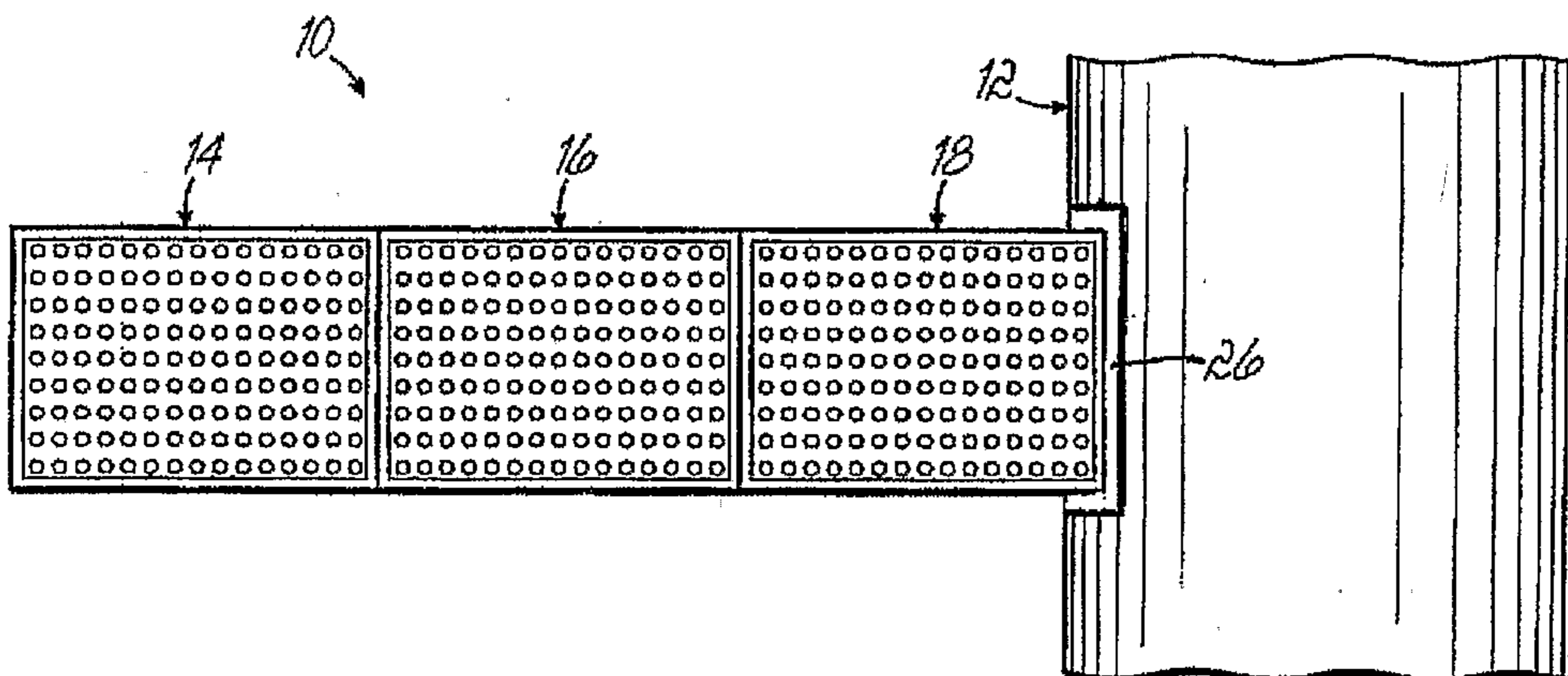

FIG. 8

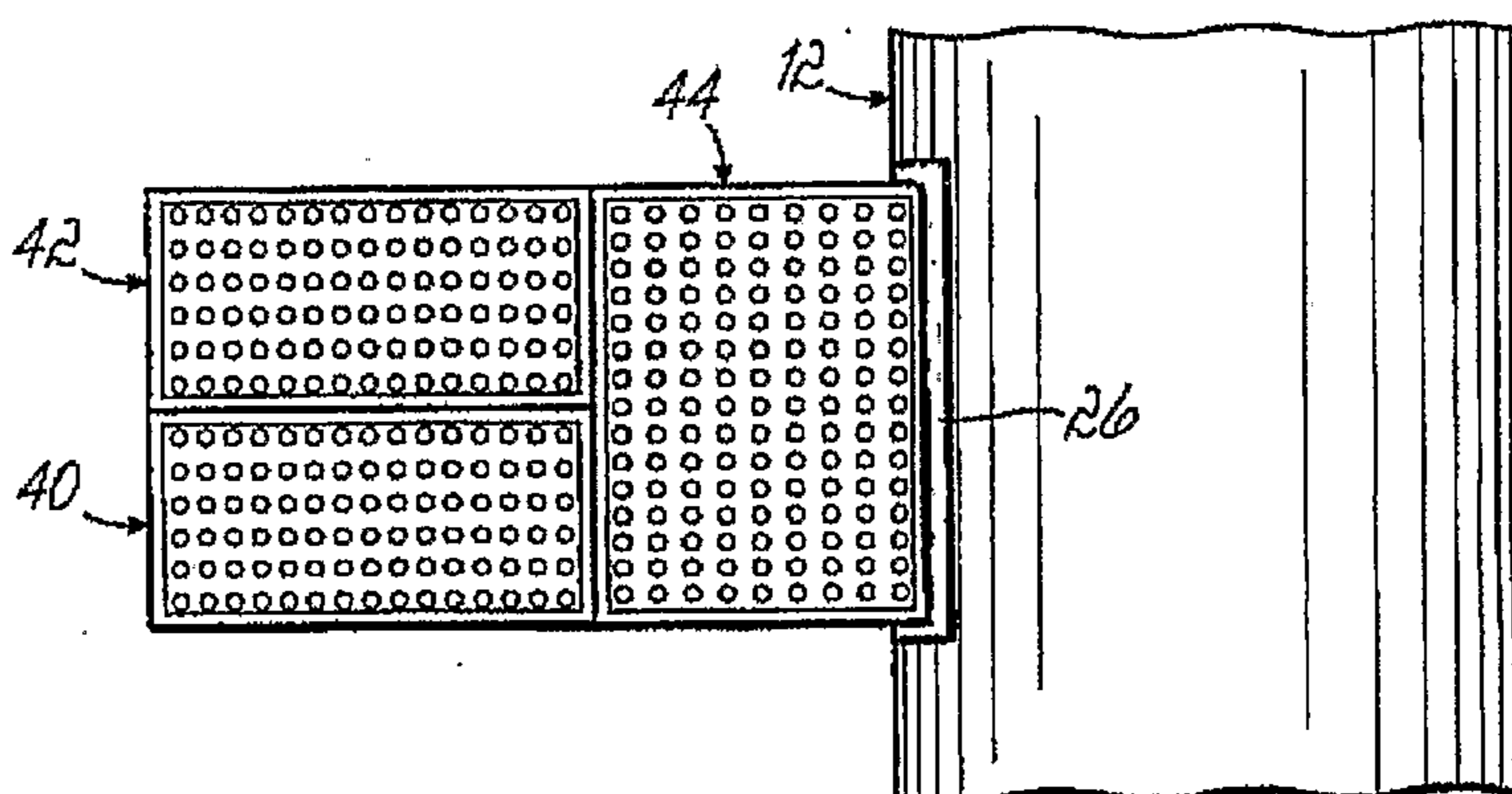

FIG. 9

