

[54] **METHOD FOR PREPARING SPUN YARNS**
 [75] Inventor: Charles W. Kim, Wilmington, Del.
 [73] Assignee: Hercules Incorporated, Wilmington, Del.
 [22] Filed: July 10, 1970
 [21] Appl. No.: 53,718

3,550,826	12/1970	Salmela	28/DIG. 1 X
3,164,948	1/1965	Stratford	57/157 R X
3,214,899	11/1965	Wininger, Jr. et al.	57/140 R
3,242,035	3/1966	White	161/168
3,273,771	9/1966	Beaumont	28/DIG. 1
3,470,685	10/1969	Hall et al.	57/140 J
3,494,522	2/1970	Kim et al.	225/97
3,496,259	2/1970	Guenther	28/DIG. 1
3,503,836	3/1970	Rasmussen	28/DIG. 1

[52] U.S. Cl.57/140 R, 28/DIG. 1, 28/72 CS, 57/157 F, 57/167, 264/DIG. 47
 [51] Int. Cl.D02g 3/22
 [58] Field of Search57/34 B, 31, 140 J, 140 R, 57/157 R, 157 F, 167; 28/DIG. 1, 72 CS; 225/3, 97; 161/168, 169; 264/DIG. 8, DIG. 47, 103

Primary Examiner—John Petrakes
 Attorney—John W. Whitson

[57] **ABSTRACT**

Spun strands are prepared by fibrillating a striated film having striations disposed at an angle to its transverse angle and twisting the resulting fibrillated product. The strand, which can be in the form of a yarn, a thread or a string, depending upon the twist level, is a true spun yarn composed of staple length fibers twisted together, as opposed to continuous filaments.

[56] **References Cited**

UNITED STATES PATENTS

3,402,548 9/1968 Wininger, Jr. et al.57/140 R

8 Claims, 3 Drawing Figures

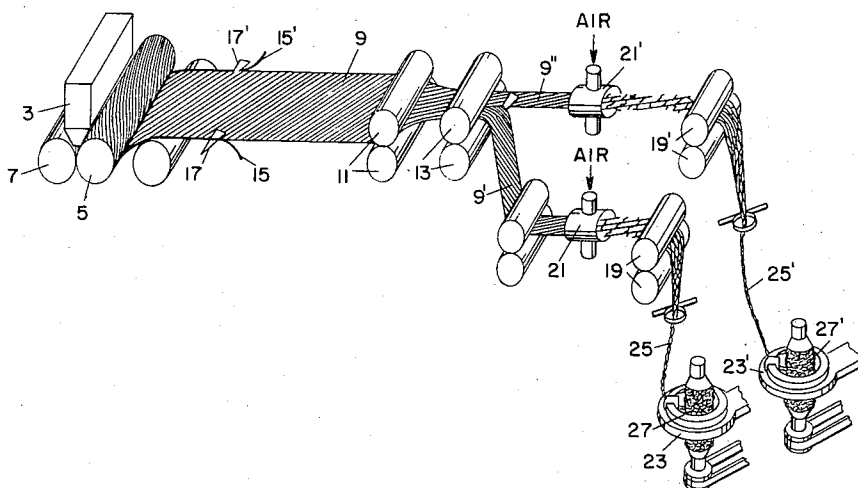

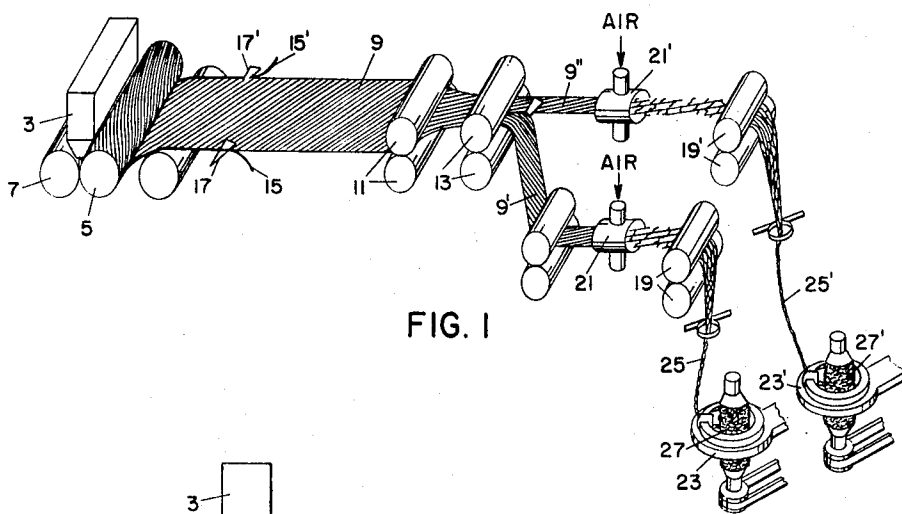

FIG. 1

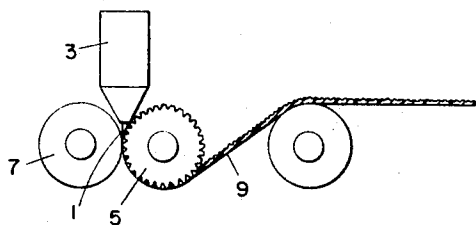

FIG. 2

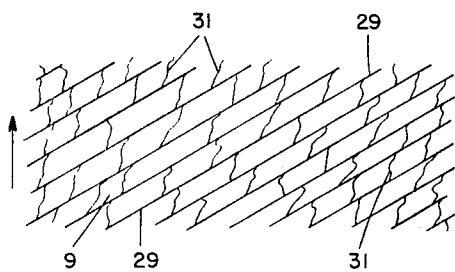

FIG. 3

CHARLES W. KIM
INVENTOR

BY

William J. Alexander

ATTORNEY

METHOD FOR PREPARING SPUN YARNS

This invention relates to a method of preparing a spun strand. In particular, it relates to such a process whereby a strand is produced of a plurality of staple length fibers with many of the time consuming conventional spun strand preparation steps being avoided.

Spun yarns of synthetic fibers are widely used in the textile industry due to their higher bulk, greater comfort and more pleasing appearance in wearing apparel as compared with continuous filaments of the same fiber-forming synthetic material. These yarns, however, are relatively expensive due to the number of steps involved in converting randomly dispersed staple fibers to yarn having fibers oriented predominantly in the axial direction. These steps consist of chopping a continuous filament tow into staple, opening, carding, spinning, and drafting the staple and finally twisting the resulting strand to impart cohesion and strength thereto and plying a number of such strands to form a yarn.

In addition to the added expense of the spun yarns incurred from the extra handling steps, the product also suffers from the necessity of balancing strength against bulk. The strength of a spun strand depends to a great degree on the extent to which it is twisted, but increasing the twist level is detrimental to bulk. Thus, it is necessary to balance bulk against strength so that a spun strand is almost necessarily lower in strength or bulk than a textured continuous filament strand of about the same denier.

A great amount of effort has been expended in searching for ways to simulate the spun look in continuous filaments so that the added handling steps can be avoided. These include various texturing methods, blending of continuous filaments and tows, use of splittable bicomponent filaments, fibrillation techniques, and many others. None, however, has produced a product having the aesthetic appeal of a true spun yarn and for the finest aesthetics, the above described multistep process continues to be the method of choice.

Now, in accordance with this invention, a method has been found whereby spun strands can be prepared by a simplified process in which the time-consuming steps of tow cutting, carding, spinning, and drafting can be eliminated and which has the added advantage of being capable of producing higher strength strands at a lower twist level than is usually possible with conventional spinning processes. The spun strands contemplated herein are in most cases, single yarns. However, it is also understood that the strands can be of a denier and twist level that they can be referred to as thread or string.

The unique method of this invention by which the above objectives are realized is based on the use of a fibrillated, diagonally striated film. Specifically, the process of the invention comprises providing a film of an organic thermoplastic fiber forming polymer having striations comprising alternating relatively thick rib sections and relatively thin web sections, said striations being disposed diagonally to the transverse axis of the film, drawing said film 2 to 8X along its longitudinal axis while allowing the edges thereof to neck, subjecting the drawn film to a stress to effect fibrillation thereof and twisting the resultant fibrillated product to form a strand.

The concept of fibrillating a film to reduce it to a fibrous state has been known to the art for some years. More recently the concept has been refined by the development of fibrillation techniques employing striated films comprising relatively thin web sections and relatively thick rib sections in which the fibrillation stresses act substantially exclusively on the thin web sections, leaving the rib sections as continuous filaments. Methods and apparatus for carrying out the fibrillation are shown in U.S. Pat. Nos. 3,470,594, 3,494,522, 3,495,752 and 3,500,627, inter alia.

The unique feature of this invention by which it is possible to prepare a spun strand is the use of a diagonally striated film. The relatively thick rib sections of such a film become staple fibers following fibrillation. When such a fibrillated film is twisted, the staple fibers engage each other in the same manner as do staple fibers in a conventional spun strand. Moreover, being diagonal to the transverse axis of the film, each rib (i.e., each staple fiber) reaches both edges of the film and thus, following fibrillation and twisting, can become a protruding backbone, giving the strand a hairy surface appearance.

This invention is illustrated in the attached drawing in which:

FIG. 1 is a perspective view of an arrangement suitable for carrying out the invention;

FIG. 2 is a section view of the film extrusion and embossing equipment; and

FIG. 3 is a schematic view of the preferred fibrillation product prepared from a diagonally striated film.

In carrying out the process of the invention with reference to FIGS. 1 and 2, a molten polymer film 1 is delivered by extruder 3 into the nip between embossing roll 5 and back-up roll 7 where the required thick and thin striated pattern is impressed thereon.

The embossed, diagonally striated film 9 is cooled and hardened in the span between embossing roll 5 and pinch rolls 11. Also in this span the edges 15 and 15' of the film are removed by slit knives 17 and 17'. These edges, as the result of shrinkage which takes place during extrusion, are slightly thicker than the remainder of the film and can interfere with subsequent fibrillation if they are not removed. The trimmed film 9 is longitudinally oriented by drawing between pinch rolls 11 and 13 with rolls 13 operated at a higher linear rate than rolls 11.

The drawn film is slit into a plurality of narrower ribbons 9' and 9'' which are drawn by pull rolls 19 and 19' through fluid jet fibrillators 21 and 21' to effect splitting of the film in the thin web sections between staple fiber backbones 29 (FIG. 3). The fibrillated film tapes 9' and 9'' are then twisted by means of twisters 23 and 23' to form strands 25 and 25' which are collected on packages 27 and 27'.

As shown in the drawing, the diagonally striated film is preferably prepared by embossing a film immediately following formation of the extruded thermoplastic. The film is preferably extruded directly into the nip between an embossing roll and its associated back-up roll with embossing taking place before the film hardens. However, if other considerations dictate, the film can be cooled, then reheated and embossed at a later time.

In order to effect diagonal striation of the film, the ribs and grooves on the embossing surface are helical

with respect to the axis of the roll. The helical angle of these ribs and grooves is dictated by the desired angle of inclination of the striations, as will be discussed more fully below.

The embossing roll can have any mechanically possible number of striations per inch on its surface. The larger the number of striations on the embossing roll, the lower will be the denier per filament of the staple fibers which results from fibrillation of a film of given thickness prepared therewith. It has been found possible to imprint as many as 200 striations per inch on a film using the embossing technique.

As an alternative to the extrusion and embossing method described hereinabove and shown in the drawing, other methods can be used to prepare the diagonally striated films employed in this invention. For example, the polymer can be extruded through a rotating, tubular film die having serrated lips. The serrated die lips cause the surface of the film to be striated and, by rotation of the die, the striations are disposed helically with respect to the longitudinal axis of the tube. Using conventional tubular film technology, this tube is slit parallel to its longitudinal axis to form a flat film with diagonal striations. In a modification of the tubular film methods, the polymer can be extruded through the same type of die which is not rotated and the film can be slit at an angle to the longitudinal axis, to form a flat film whose longitudinal axis is different from that of the tube from which it was slit and which has striations diagonal to this new longitudinal axis. The films from either of these alternative procedures are then slit into ribbons of the proper width, drawn, fibrillated, and twisted in the same way that embossed films are handled.

The diagonally striated film is then subjected to a cold, orienting draw of 2 to 8X in the longitudinal direction. This draw serves the dual purpose of increasing the strength of the ribs and of rendering the film fissile in the web sections between the ribs. This fissility of the web sections is required in order for the film to fibrillate and separate the ribs into staple fibers.

In carrying out the longitudinal draw, it is essential that the film be permitted to draw through a neck, i.e., the edges of the film must not be restrained during drawing. If the edges are restrained, the film will tend to draw along lines parallel to the longitudinal axis of the film. Since the film contains thick and thin areas, a stress applied while restraining the edges would be concentrated in the thin areas, resulting in splitting thereof. When the edges of the film are not restrained and the film is free to neck down, the drawing stress is distributed evenly across the web and the ribs as well as the thin webs are drawn at an angle approaching longitudinal.

In addition to being able to neck down, it is desirable that the relatively thick ribs be disposed before drawing, at an angle of at least about 45° to the transverse axis of the film in order for the drawing stress to be transmitted thereto. Films with the ribs at less than 45° to the transverse axis can be drawn if they are first twisted to reorient the ribs in the general direction of the drawing force. Drawing under these circumstances, however, does not yield as favorable a degree of orientation.

During drawing, the film is permitted to neck down in such a way that the relationship of the width of the film to its thickness remains the same as it was before drawing. Under these conditions, the width of the film decreases to a fraction of its original width equal to the reciprocal of the square root of the draw ratio. Thus, for example, a draw of 4X results in a decrease in width to about one-half of the original. In so doing, it also increases the angle of the diagonal ribs with respect to the transverse axis of the film. The amount of this increase, of course, will also be a function of the draw ratio. This factor must be considered in determining the helical angle of the ribs on the embossing roll.

The drawn, diagonally striated film is then subjected to a fibrillating stress whereby the oriented, thin web sections of the film are split and the thick rib portions are separated as staple fibers of a uniform, predetermined length. The degree of fibrillation can be regulated so that the fibrillation stops short of total separation of the ribs, leaving the ribs lightly bound by means of very low denier fibrils of the oriented web section or fibrillation can be complete so that the ribs are substantially completely freed from one another.

As depicted in the drawing, the fibrillation step is carried out by means of a fluid jet fibrillator. Apparatus of this type and the process for using it are described in U.S. Pat. No. 3,470,594. The degree of fibrillation accomplished on the film can be regulated by regulating the flow of air employed to effect fibrillation in relation to the speed of the film as it passes through the fibrillation zone. The determination of the precise conditions for this operation is within the skill of the art simply by observing the fibrillation product and making adjustments in the air flow accordingly.

At this point in the process, the preferred fibrillated product as depicted in FIG. 3 is a network of staple fibers 29 loosely connected to one another by a network of fibrils 31 and disposed essentially parallel to one another at an angle to the transverse axis of the film (indicated by the arrow) from which they are prepared. A twist is inserted into this product to convert it into a strand. Inasmuch as the rib sections of the fibrillated product are staple fibers, the strand which results therefrom has the identical structure of a true spun yarn as opposed to the simulated spun yarns resulting from many techniques previously taught.

As stated hereinabove, the film can be fibrillated completely so that it is reduced to individual staple fibers. In such a case, provision is made for maintaining sufficient structural integrity to enable the fibers to be transferred to the twister from the point where fibrillation is accomplished. This integrity can be provided, e.g., by insertion of a false twist in the yarn immediately following fibrillation or by means of a nonpermanent adhesive material which is readily removed by scouring in the manner that spun sizings are removed from conventional synthetic yarns. When fibrillation is accomplished by means of the fluid jet, the resultant fibers are frequently tangled with each other sufficiently to yield the necessary degree of cohesion until they are twisted together.

For most purposes, the fibrillated film which is to be twisted into a strand is between about ¼ and 3 inches wide, depending upon the total denier of the strand which is to be prepared. The film can be extruded

directly in the size required, or as shown in the drawing it can be extruded as a wider film, and slit to a plurality of tapes or ribbons of the desired width. In either event the edges of the film are usually removed as shown in the drawing because during extrusion the edges form a bead of greater thickness than the remainder of the film and the presence of this bead can interfere with fibrillation by not permitting the ends of the strands to be freed after twisting. Twisting can be accomplished according to known methods of twisting staple fibers into spun yarns. A preferred way to accomplish twisting is by means of a down-twister. Usually a twist level of about one to 10 twists per inch is employed to prepare a coherent strand structure.

Upon being twisted into a strand, each fiber has two free ends which can protrude from the surface of the strand to give it the appearance and bulk of a conventionally spun strand. These ends are either free at the time of twisting or are freed during further handling of the strand by stresses which cause the webs binding them to break. The number of such free ends present per unit length of the strand depends on the number of striations per inch on the unstretched film and the draw ratio according to the following equation:

$$\text{Number of protruding ends/unit length} = (2 \times \text{Number of striations/unit length of undrawn film})/\text{draw ratio}$$

Staple fiber strands prepared by the method of this invention have several advantages over spun strands prepared by more conventional methods in addition to the economic advantage occasioned by the more limited handling of the strand. For example, the length of the staple fibers is quite uniform, varying primarily only to the extent that the width of the film varies. Additionally, the range of staple fiber lengths which can be handled is much wider than can be handled in the conventional carding and spinning process. For example, if the film which is twisted is just $\frac{1}{4}$ inch wide prior to drawing and fibrillation and the angle between the filaments and the transverse axis of the film is $89^{\circ} 50$ minutes, a staple fiber of about 10 feet in length results from a 6X draw. The length of the staple fibers can be calculated according to the formula:

Staple Fiber Length

$$(L) = \sqrt{(W)^2/R + [R \times \tan \theta \times W]^2}$$

where W is the width of the film section before drawing, R is the draw ratio and θ is the original angle between the filament and the transverse axis of the film.

The case cited above is obviously an extreme case. Generally, the staple fibers will be between about 2 and 30 inches in length. The greater length of the staple fibers which can be and which are employed in this invention leads to greater strand strength than is obtainable with a comparable degree of twist using shorter staple fibers. Accordingly, the need to trade off strength against bulk, as mentioned above, is substantially lessened using the process of this invention.

Another advantage of the process of this invention is that the problem of shedding and pilling frequently encountered with other spun synthetic materials is eliminated or, at least, substantially decreased. Shedding and pilling are caused by the presence of short fibers which pull out of the strand relatively easily. Since short fibers are not present in these products,

it is difficult for fibers to pull out and cause pilling or shedding.

As the above equation shows, the length of the staple fibers for a specific film width is a function of the angle θ which the fibers make with the transverse axis of the film prior to drawing. This angle, in turn, is a function of the helical angle of the embossing grooves and the draw ratio applied to the film. It is preferable that θ be greater than 45° . It should be obvious that θ cannot be 90° as the fibers would then be continuous filaments and a strand twisted therefrom would be a smooth, continuous filament yarn.

A plurality of strands prepared according to the process of this invention can be twisted together to form a ply yarn as is customarily done in the textile fiber art. Known procedures for twisting a plurality of strands together and for setting the twist can be employed. A yarn prepared by plying strands prepared according to the process of this invention can be employed in any application where conventional spun yarns are presently employed.

The process of the invention is applicable to any of the known thermoplastic film and fiber forming synthetic polymers. Exemplary of such polymers are polyolefins such as polypropylene, polyamides such as nylon, polyesters such as polyethylene terephthalate, and the acrylic polymers. Blends and composites of such materials can also be used when specific property combinations are sought.

What I claim and desire to protect by Letters Patent is:

1. A process which comprises providing a thermoplastic film having substantially parallel striations formed diagonally to the transverse axis of the film, said striations forming alternating relatively thick rib sections and relatively thin web sections; drawing said film along its longitudinal axis while allowing the film to neck down to orient the rib sections along their longitudinal axes; subjecting the drawn film to a fibrillating stress to effect splitting of the web sections; and twisting the fibrillated structure into a strand.

2. A process which comprises providing a thermoplastic film having substantially parallel striations formed diagonally to the transverse axis of the film and extending continuously across the film, said striations forming alternating relatively thick rib sections and relatively thin web sections; drawing said film along its longitudinal axis while allowing the film to neck down to orient the rib sections along their longitudinal axes; subjecting the drawn film to a fibrillating stress to effect partial fibrillation thereof to form a net-like structure wherein the relatively thick axially oriented ribs are interconnected by thin fibrils; and twisting the resulting net-like structure into a strand.

3. The process of claim 2 where fibrillation is effected by means of an air jet.

4. The process of claim 2 including the additional step of plying a plurality of said strands.

5. The process of claim 2 where the angle between the striations and the transverse axis of the film is at least about 45° before drawing.

6. A spun strand comprising a plurality of thermoplastic fibers oriented along their longitudinal axes and having a substantially constant length and substantially constant thickness and cross-section disposed in

substantially parallel relationship to one another, each such fiber being connected to adjacent fibers by a plurality of relatively thinner fibrils, said plurality of fibers being twisted into a strand and having at least some of the ends thereof protruding from said strand.

7. A network structure comprising a plurality of relatively thick thermoplastic fibers oriented along their longitudinal axes and having a substantially constant length and substantially constant thickness and cross-section, said fibers being interconnected by a plurality of relatively thin fibrils, each of said fibrils having their ends connected to adjacent fibers, said fibers being substantially parallel to one another and being disposed

at an angle to the transverse axis of the network and extending continuously across the network.

8. A spun strand comprising a plurality of fibers oriented along their longitudinal axes and having a substantially constant length and substantially constant thickness and cross-section disposed in substantially parallel relationship to one another, said plurality of fibers each having portions of fibrils which are thinner than said fibers integrally connected thereto and protruding along the length thereof, said plurality of fibers being twisted into a strand and having at least some of the ends thereof protruding from said strand.

* * * * *

15

20

25

30

35

40

45

50

55

60

65